

DPW Offices and Garage



Town of Sudbury ADA Transition Plan

October 2020



Institute for Human Centered Design

200 Portland Street, Boston, MA 02114
www.IHCDesign.org • info@IHCDesign.org
617-695-1225 voice/ tty

Background

Year Built: 2004

Sudbury Department of Public Works (DPW) offices and garage are located at 275 Old Lancaster Road. The two-story building has three accessible entrances and exits. The first floor has offices for engineering, board of health, conservation, planning, building department, the transfer station and cemetery department, operations department and a social worker's office. There are also multi-user women's and men's toilet rooms and a drinking fountain for seated users. The garage building is located at a lower level on the east side of the office building, connected via a flight of stairs. IHCD team was told it is not accessed by the public and therefore was not surveyed.

Parking for the office building is located on the west side of the building. This lot contains a van accessible and car accessible parking space.

Key Accessibility Issues

Parking Lot

The access aisle from the car accessible parking space does not lead to an accessible route and lacks a curb ramp.

Exterior Route

The sidewalk in front of the building on the west side narrows to less than 36 inches due to a vehicle charging station, untrimmed hedges and cars that project over the sidewalk due to lack of wheel stops.

Egress Signage

Exit doors lack signs with raised characters and braille. Accessible exits lack illuminated signs with the International Symbol of Accessibility (ISA).

Vertical Circulation

There is no interior accessible vertical route between the office level and garage level, however the public does not access the

garage level. For this reason, an estimate for accessible means of vertical circulation is not included in this report.

Toilet Rooms

Accessibility issues in toilet rooms include dispensers mounted higher than allowed, dispensers with controls that are not operable with a closed fist, dispensers that are protruding objects in the circulation path, malfunctioning self-closing hinges at wheelchair accessible compartments, lack of compliant hardware at wheelchair accessible compartments, and lack of required clear width at the urinal.

Drinking Fountain

One drinking fountain for seated users is provided, however it lacks 27 inches clear space for knee and toe clearance, and a drinking fountain is not provided for standing users.

Additional Accessibility Issues

- Two work surfaces lack clear floor space and one work surface lacks toe and knee clearance.
- Protruding objects are present in circulation routes.
- Designation signage lacks clear floor space in two locations and the signage is not located on the latch side of the door in one location.
- Mats throughout the facility are not secured.
- The picnic table is not located on an accessible route.
- One clothing rod is located higher than allowed.
- Many forms are located higher than allowed.

Order of Magnitude Cost Estimates

- Provide a curb ramp at the car accessible parking space: \$2,800
- Provide compliant egress signage: \$1,296
- Renovate toilet rooms: \$3,223
- Install a Hi-Lo drinking fountain: \$4,216
- Miscellaneous corrective actions (protruding objects, reach range, work surfaces, accessible route to picnic table, etc.): \$1,902

Total: \$13,437*

*Cost estimate for providing wheel stops at parking spaces and relocating the car charging station is beyond the scope of the project.

Best Practice and Inclusive Design

Best practice and inclusive design recommendations include elements that are not required in the standards but may create enhanced experiences for all users.

- Recommend increasing lighting outside of the engineering office so that signage is more legible.
- Recommend providing a designation sign with raised characters and braille at the engineering conference room.
- Recommend providing an accessible charging station. The ADA Standards do not include specific provisions for electric vehicle (EV) charging stations. However, it is advisable to address access to EV charging stations so that they are usable by people with disabilities. See the following diagram:

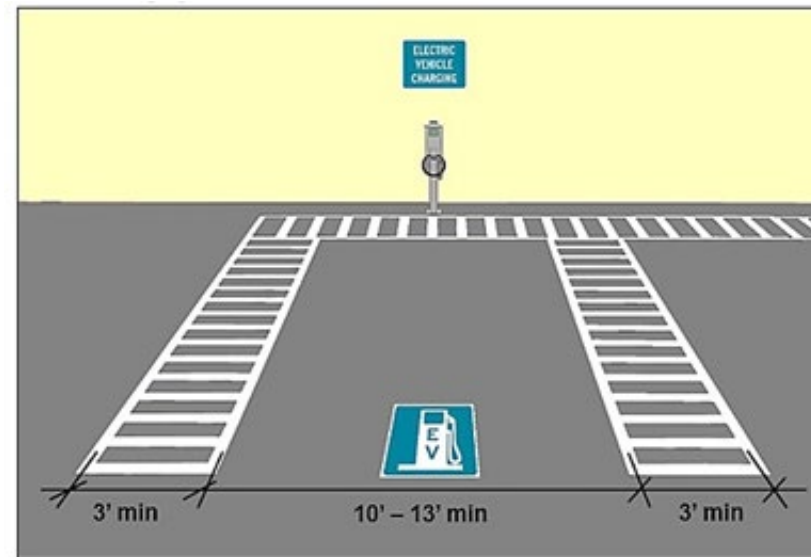



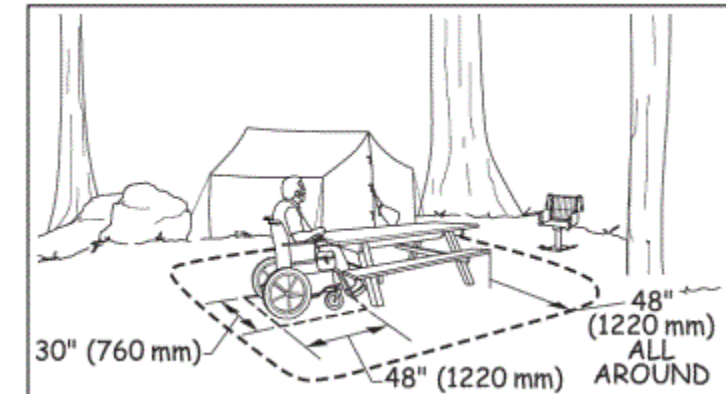

- Provide a 3' wide min. striped accessible route on both sides of the vehicle space that connects to the charging station for easier access.
- A vehicle space at least 10' – 13' wide is advisable. A 10' width offers an extra 2' that effectively provides a 5' aisle on one side when paired with the accessible route; a 13' wide space will allow an 8' aisle. This flexibility is helpful since the parking direction is determined by the location of the charging station and the vehicle connection. Use the International Symbol of Accessibility (ISA) only where

spaces are reserved exclusively for people with disabilities.





- Recommend providing an accessible 48-inch wide route around the picnic table with concrete, asphalt or stone dust. See the following diagram:





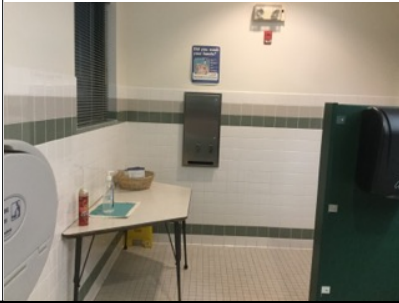

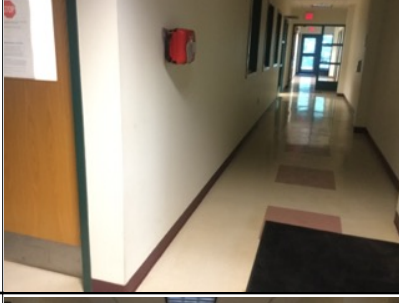
**Town of Sudbury
DPW Offices and Garage**

ID	Location	Floor	Room	Element	Type	Photo	Issues	Current Measure	Recommendations	Quantity	Price	Cost Estimation
Approach and Entrance												
Exterior Access Route												
1	Front Walkway	Ext.		Exterior Access Route	Sidewalk		Exterior route < 36" wide Exterior route < 48" wide	27.75" -	Ensure that a clear width of 36" min. is maintained at the accessible route with 48" preferred per 521 CMR. Relocate car charging station so that there is 36" clear min. Trim hedges and install wheel stops so that vehicles do not block the sidewalk. (Cost is beyond the scope of the project.)	1	-	\$0
Off-Street Parking Lot or Garage												
2	Parking Lot - Car Accessible Space Access Aisle	Ext.		Off-Street Parking Lot or Garage	Visitor		Access aisle does not adjoin an accessible route	-	Ensure the access aisle by the car accessible space adjoins an accessible route. Provide a curb ramp.	1	2800	\$2800
Emergency Exit												
3	Central Exit	1		Emergency Exit	N/A		Tactile sign not provided at exit Illuminated Int. Symbol of Acc. not provided (MAAB) Mat not securely attached	- - -	Provide tactile exit signs with raised characters and braille at exit doors. Mount signs between 48"- 60" above the finished floor located on the latch side of the door. Provide an illuminated sign with the International Symbol of Accessibility. Secure the mat.	1	432 Labor	\$432
4	South Exit	1		Emergency Exit	N/A		Tactile sign not provided at exit Illuminated Int. Symbol of Acc. not provided (MAAB) Mat not securely attached	- - -	Provide tactile exit signs with raised characters and braille at exit doors. Mount signs between 48"- 60" above the finished floor located on the latch side of the door. Provide an illuminated sign with the International Symbol of Accessibility. Secure the mat.	1	432 Labor	\$432





**Town of Sudbury
DPW Offices and Garage**

ID	Location	Floor	Room	Element	Type	Photo	Issues	Current Measure	Recommendations	Quantity	Price	Cost Estimation
5	North Exit	1		Emergency Exit			Tactile sign not provided at exit Illuminated Int. Symbol of Acc. not provided (MAAB) Mat not securely attached	- - -	Provide tactile exit signs with raised characters and braille at exit doors. Mount signs between 48"- 60" above the finished floor located on the latch side of the door. Provide an illuminated sign with the International Symbol of Accessibility. Secure the mat.	1	432 Labor	\$432
Access to Goods and Services												
Interior Access Route												
6	Women's Toilet Room	1		Interior Access Route	N/A		Route < 36" wide	30"	Relocate table to ensure that a clear width of 36" min. is maintained at the accessible route. Route is allowed to narrow to narrow to 32" for a depth of 24".	1	Labor	\$0
7	Board of Health	1		Interior Access Route	N/A		Route < 36" wide	35.25"	Relocate cabinets to ensure that a clear width of 36" min. is maintained at the accessible route.	1	Labor	\$0
8	Corridor by Main Entrance	1		Interior Access Route	N/A		Obstructed by protruding objects	5"	Relocate or recess fire alarm box.	1	256	\$256
9	Application Forms Area/Overlook	1		Interior Access Route	N/A		Obstructed by protruding objects	41.5"	Provide a cane-detectable barrier on the open side of the high counter.	1	306	\$306





**Town of Sudbury
DPW Offices and Garage**

ID	Location	Floor	Room	Element	Type	Photo	Issues	Current Measure	Recommendations	Quantity	Price	Cost Estimation
10	Near Main Entrance	1		Interior Access Route	N/A		Surface not stable, firm, and slip-resistant	-	Secure mats.	2	Labor	\$0
11	Transfer Station Cemetery Department	1		Interior Access Route	N/A		Surface not stable, firm, and slip-resistant	-	Secure mat.	1	Labor	\$0
Doors, Doorways, & Gates												
12	Women's Toilet Room	1		Doors, Doorways, & Gates	Toilet Room		Maneuvering clearance(s) not provided	-	Relocate trash container so that there is 18" min. on the pull side of the door.	1	Labor	\$0
13	Conference Room	1		Doors, Doorways, & Gates	Meeting Room		Maneuvering clearance(s) not provided	-	Relocate table so that there is 18" min. on the latch side of the door.	1	Labor	\$0
Signage												
14	Transfer Station Cemetery Department	1		Signage	Designation		Sign not located on the latch side of the door	-	Locate sign at permanent rooms alongside the door on the latch side.	1	Labor	\$0



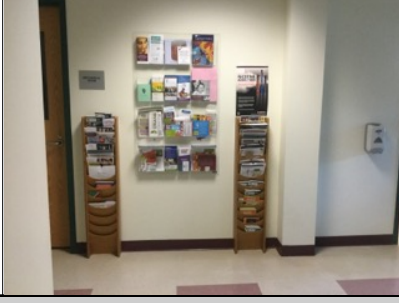

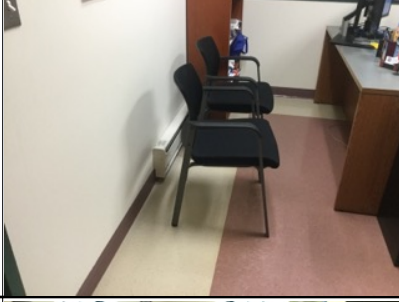
**Town of Sudbury
DPW Offices and Garage**

ID	Location	Floor	Room	Element	Type	Photo	Issues	Current Measure	Recommendations	Quantity	Price	Cost Estimation
15	Engineering Near Main Entrance	1		Signage	Designation		Signage lacks clear floor space	-	Remove the plastic container to ensure that a clear floor space of 18" by 18" is centered on the tactile characters.	1	Labor	\$0
16	Conservation	1		Signage	Designation		Signage lacks clear floor space	-	Remove the file folder to ensure that a clear floor space of 18" by 18" is centered on the tactile characters.	1	Labor	\$0
Operable Parts												
17	Application Forms Area/Overlook	1		Operable Parts	Other		Reach < 15" or > 48"(forward/side approach)	63"	Relocate one of each form to be located between 15"- 48" above the finished floor.	1	Labor	\$0
18	Transfer Station Cemetery Department	1		Operable Parts	Clothes Rod/Hooks		Reach < 15" or > 48"(forward/side approach)	62.5"	Relocate clothes rod to be no higher than 48" above the finished floor.	1	256	\$256
19	Transfer Station Cemetery Department	1		Operable Parts	Other		Reach < 15" or > 48"(forward/side approach)	56"	Relocate one of each form to be located between 15"- 48" above the finished floor.	1	Labor	\$0





**Town of Sudbury
DPW Offices and Garage**

ID	Location	Floor	Room	Element	Type	Photo	Issues	Current Measure	Recommendations	Quantity	Price	Cost Estimation
20	Corridor Near Mail/Copy Room	1		Operable Parts	Other		Reach < 15" or > 48"(forward/side approach)	61", 73"	Relocate one of each form to be located between 15"- 48" above the finished floor.	1	Labor	\$0
21	Corridor Near Mail/Copy Room	1		Operable Parts	Other		Reach < 15" or > 48"(forward/side approach)	61", 73"	Relocate one of each form to be located between 15"- 48" above the finished floor.	1	Labor	\$0
Dining or Work Surfaces												
22	Conservation	1		Dining or Work Surfaces	Work Surface		Knee or toe clearance not provided	26.5"	Provide at least 1 dining or work surface with 27" min. knee and toe clearance.	1	700	\$700
23	Director of Operations	1		Dining or Work Surfaces	Work Surface		Clear floor space not provided at work surface	44"	Relocate desk so that there is 48" clear min.	1	Labor	\$0
24	Conservation	1		Dining or Work Surfaces	Work Surface		Clear floor space not provided at work surface	37"	Relocate desk so that there is 48" clear min.	1	Labor	\$0





**Town of Sudbury
DPW Offices and Garage**

ID	Location	Floor	Room	Element	Type	Photo	Issues	Current Measure	Recommendations	Quantity	Price	Cost Estimation
Picnic Tables												
25	Picnic Table by North Exit	Ext.		Picnic Tables	N/A		Picnic table not on an accessible route	-	Ensure that the dining surface is connected to an accessible route. (Cost estimate for a 6' long 4' wide concrete route.)	1	384	\$384
Toilet & Bathing Rooms												
Lavatory												
26	Men's Toilet Room	1		Lavatory	N/A		Dispensers not within reach range	47"	Lower the soap dispenser to 42" max. above the floor.	1	353	\$353
Toilet Compartment												
27	Women's Toilet Room	1		Toilet Compartment			Door has non-compliant hardware	-	Provide hardware that can be operable with one hand and not require tight grasping, pinching, or twisting of the wrist.	1	70	\$70
28	Men's Toilet Room	1		Toilet Compartment	Accessible Compartment		Door has non-compliant hardware Door has malfunctioning self-closing hinge	- -	Provide hardware that can be operable with one hand and not require tight grasping, pinching, or twisting of the wrist. Repair hinge.	1	70 Labor	\$70



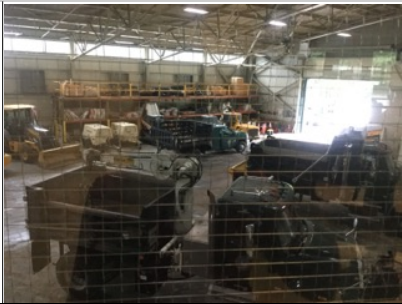

**Town of Sudbury
DPW Offices and Garage**

ID	Location	Floor	Room	Element	Type	Photo	Issues	Current Measure	Recommendations	Quantity	Price	Cost Estimation
29	Women's Toilet Room	1		Toilet Compartment	Accessible Compartment		Door has malfunctioning self-closing hinge	-	Repair hinge.	1	Labor	\$0
30	Women's Toilet Room	1		Toilet Compartment			Non-compliant toilet paper dispenser	-	Remove toilet paper dispenser that is mounted above the grab bar.	1	353	\$353
Urinal												
31	Men's Toilet Room	1		Urinal	N/A		Urinal recessed > 24" has > 36" clear width	32"	If urinal is recessed greater than 24" ensure there is a clear width of 36". Relocate the partition.	1	353	\$353
Dispensers												
32	Women's Toilet Room	1		Dispensers	Tampon Dispenser		Not operable with a closed fist	-	Provide a dispenser that can be operable with one hand and not require tight grasping, pinching, or twisting of the wrist.	1	1000	\$1000
33	Women's Toilet Room	1		Dispensers	Paper Towel Dispenser		Dispenser acts as a protruding object	9"	Relocate paper towel dispensers out of the circulation path.	2	256	\$512

**Town of Sudbury
DPW Offices and Garage**

ID	Location	Floor	Room	Element	Type	Photo	Issues	Current Measure	Recommendations	Quantity	Price	Cost Estimation
34	Men's Toilet Room	1		Dispensers	Paper Towel Dispenser		Dispenser acts as a protruding object	9"	Relocate paper towel dispensers out of the circulation path.	2	256	\$512
Additional Access												
Drinking Fountains												
35	Drinking Fountain Near Women's Toilet Room	1		Drinking Fountains	Low		No drinking fountain provided for standing users Knee or toe clearance not provided	- 26"	Install a Hi-Lo drinking fountain. Provide knee and toe clearance, 27" min. high at drinking fountain for seated users.	1	4216	\$4216
Overall Review												
36	DPW Garage	1							Garage is not currently accessed by members of the public.	1	-	\$0
Best Practice												
37	Main Entrance	1							This is a good example of a recessed floor mat.	1	-	\$0

**Town of Sudbury
DPW Offices and Garage**

ID	Location	Floor	Room	Element	Type	Photo	Issues	Current Measure	Recommendations	Quantity	Price	Cost Estimation
38	Engineering Near Main Entrance	1							Recommend increasing lighting in this area so that signage is more legible.	1	-	\$0
39	Engineering Conference Room	1							Recommend providing designation sign with raised character and braille even though a sign is not provided.	1	-	\$0
40	Front Walkway	Ext.							Recommend providing an accessible vehicle charging station with 3' min. access aisles on each side and a 10'-13' wide vehicle space.	1	-	\$0
41	Picnic Table by North Exit	Ext.							Recommend providing an accessible 48-inch wide route around the picnic table with concrete, asphalt or stone dust.	1	-	\$0