

MASSACHUSETTS DEPARTMENT OF TRANSPORTATION HIGHWAY DIVISION

SUDBURY BRUCE FREEMAN RAIL TRAIL			
STATE	FED. AID PROJ. NO.	SHEET NO.	TOTAL SHEETS
MA	XXX-XXXX(XXX)X	1	316
PROJECT FILE NO.		608164	

TITLE SHEET & INDEX

PLAN AND PROFILE OF BRUCE FREEMAN RAIL TRAIL

IN THE TOWN OF SUDBURY & CONCORD MIDDLESEX COUNTY

FEDERAL AID PROJECT NO. XXX-XXXX(XXX)X

PERMITTING PLAN SET NOT FOR CONSTRUCTION

100% SUBMITTAL

THE COMMONWEALTH OF MASSACHUSETTS DEPARTMENT OF TRANSPORTATION STANDARD SPECIFICATIONS FOR HIGHWAYS AND BRIDGES 2021 EDITION, THE OCTOBER 2017 CONSTRUCTION STANDARD DETAILS, THE 2015 OVERHEAD SIGNAL STRUCTURE AND FOUNDATION STANDARD DRAWINGS, MASSDOT TRAFFIC MANAGEMENT PLANS AND DETAIL DRAWINGS, THE LATEST MANUAL ON UNIFORM TRAFFIC CONTROL DEVICES FOR STREETS AND HIGHWAYS WITH MASSACHUSETTS AMENDMENTS, THE 1990 STANDARD DRAWINGS FOR SIGNS AND SUPPORTS, THE 1968 STANDARD DRAWINGS FOR TRAFFIC SIGNALS AND HIGHWAY LIGHTING, AND THE LATEST EDITION OF THE AMERICAN STANDARD FOR NURSERY STOCK, WILL GOVERN.

PERMITTING PLAN SET PAGE NO.	SHEET NO.	DESCRIPTION
1	1	TITLE SHEET & INDEX*
2	2	GENERAL NOTES*
3	3	LEGEND & ABBREVIATIONS*
4-5	4-5	KEY PLAN & BORING LOCATIONS*
	6-8	BORING LOGS
6-10	9-14	TYPICAL SECTIONS*
11-39	1-29	ENVIRONMENTAL IMPACTS*
40-68	15-46	CONSTRUCTION PLANS*
69-80	47-61	PROFILES*
	62-93	CURB & BASELINE TIE PLANS
81-109	94-122	GRADING PLANS*
	123-154	PAVEMENT MARKING & SIGNING PLANS
	155-157	TRAFFIC SIGN SUMMARY
	158-163	TRAFFIC SIGNAL PLANS
	164-169	TEMPORARY TRAFFIC CONTROL PLANS
110-138	170-201	DRAINAGE & UTILITY PLANS*
139-140	202-203	WETLAND REPLICATION PLANS*
141-152	204-217	CONSTRUCTION DETAILS*
153-154	218-219	WHEELCHAIR RAMP DETAILS*
155-176	220-241	BRIDGE PLANS*
177-241	242-316	CROSS SECTIONS*

* INDICATES TO BE INCLUDED IN PERMITTING PLANS

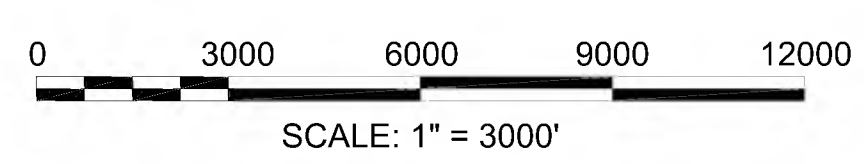
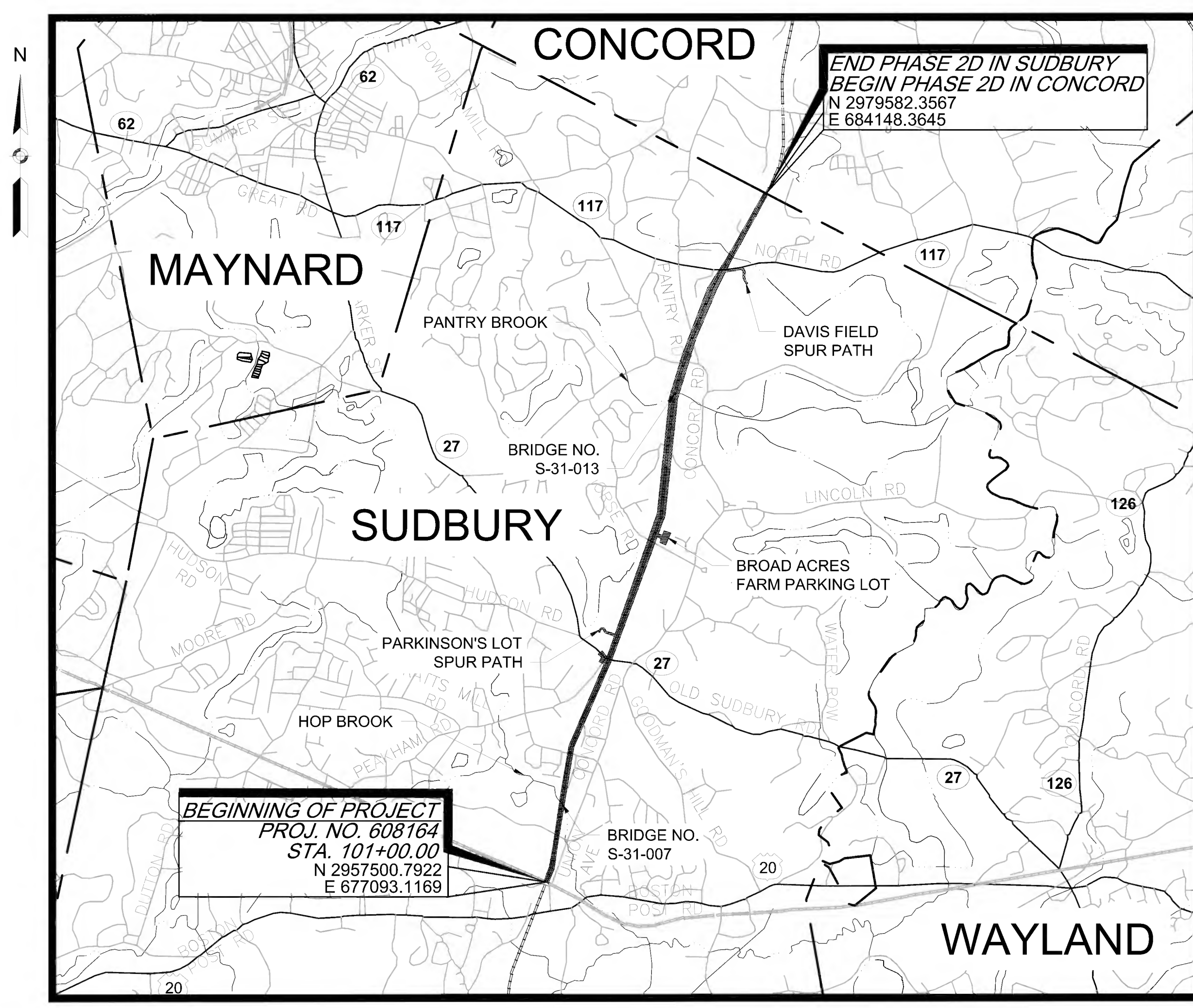

LENGTH OF PROJECT = 23,542.00 FEET = 4.459 MILES

DATE	DESCRIPTION	REV #
2-18-2022	FINAL NOI SUBMISSION	2
1-18-2022	100% DESIGN SUBMISSION	1
12-22-2021	NOI SUBMISSION	1
5-12-2021	75% DESIGN SUBMISSION	1

FUSS & O'NEILL
190 HIGH STREET
BOSTON, MA 02110
617.282.4675
www.fando.com



RECOMMENDED FOR APPROVAL

CHIEF ENGINEER	DATE

DEPARTMENT OF TRANSPORTATION
FEDERAL HIGHWAY ADMINISTRATION

APPROVED:

DIVISION ADMINISTRATOR	DATE

GENERAL ABBREVIATIONS

ABAN	ABANDON
ADJ	ADJUST
APPROX	APPROXIMATE
A.C.	ASPHALT CONCRETE
ACCM PIPE	ASPHALT COATED CORRUGATED METAL PIPE
BIT.	BITUMINOUS
BC	BOTTOM OF CURB
BD.	BOUND
BL	BASELINE
BLDG	BUILDING
BM	BENCHMARK
BO	BY OTHERS
BOS	BOTTOM OF SLOPE
BR.	BRIDGE
CC	CEMENT CONCRETE
CCM	CEMENT CONCRETE MASONRY
CEM	CEMENT
CI	CURB INLET
CLF	CHAIN LINK FENCE
CL	CENTERLINE
CO.	COUNTY
CONC	CONCRETE
CONT	CONTINUOUS / CONTINUED
CONST	CONSTRUCTION
CR GR	CROWN GRADE
DIA	DIAMETER
DWY	DRIVEWAY
ELEV (or EL.)	ELEVATION
EMB	EMBANKMENT
EOP	EDGE OF PAVEMENT
EQ	EQUAL
EXIST (or EX)	EXISTING
EXC	EXCAVATION
FDN.	FOUNDATION
FDP	FULL DEPTH PAVEMENT
FLDSTN	FIELDSTONE
GAR	GARAGE
GD	GROUND
GRAN	GRANITE
GRAV	GRAVEL
GRD	GUARD
HMA	HOT MIX ASPHALT
HOR	HORIZONTAL
HWY	HIGHWAY
JCT	JUNCTION
LOAM	LOAM BORROW
LSA	LANDSCAPED AREA
LT	LEFT
MAHWL	MEAN AVERAGE HIGH WATER LINE
MAX	MAXIMUM
MB	MAILBOX
MHB	MASSACHUSETTS HIGHWAY BOUND
MIN	MINIMUM
MOD	MODIFIED
MSE	MECHANICALLY STABILIZED EARTH
NERR	NEW ENGLAND RAILROAD
NIC	NOT IN CONTRACT
NO.	NUMBER
NTS	NOT TO SCALE
O.C.	ON CENTER
O.D.	OUTSIDE DIAMETER
P.G.L.	PROFILE GRADE LINE
PREV	PREVIOUS/PREVIOUSLY
PROJ	PROJECT
PROP	PROPOSED
PSB	PLANTABLE SOIL BORROW
PVMT	PAVEMENT
R&D	REMOVE AND DISCARD
R&R	REMOVE AND RESET
R&S	REMOVE AND STACK
RD	ROAD
RDWY	ROADWAY
REB	REBUILD
REM	REMOVE
REMOD	REMODEL
RET	RETAIN
RET WALL	RETAINING WALL
ROW	RIGHT OF WAY
RR	RAILROAD
RT	RIGHT
SB	STONE BOUND
SHLD	SHOULDER
SHLO/S.H.L.O.	STATE HIGHWAY LAYOUT LINE

GENERAL ABBREVIATIONS (CONT)

ST	STREET
STA	STATION
STD	STANDARD
SW	SIDEWALK
TEMP	TEMPORARY
TC	TOP OF CURB
TOS	TOP OF SLOPE
TRANS	TRANSITION
TRM	TURF REINFORCING MAT
TYP	TYPICAL
VAR	VARIES
VERT	VERTICAL
WCR	WHEEL CHAIR RAMP
WP	WORKING POINT
X-SECT	CROSS SECTION

UTILITY ABBREVIATIONS

CB	CATCH BASIN
CBCI	CATCH BASIN WITH CURB INLET
CIP	CAST IRON PIPE
CIT	CHANGE IN TYPE
CMP	CORRUGATED METAL PIPE
CSP	CORRUGATED STEEL PIPE
DI	DROP INLET
DIP	DUCTILE IRON PIPE
FES	FLARED END SECTION
F&C	FRAME AND COVER
F&G	FRAME AND GRATE
GG	GAS GATE
GI	GUTTER INLET
GIP	GALVANIZED IRON PIPE
HDPE	HIGH DENSITY POLYETHYLENE PIPE
HDW	HEADWALL
HYD	HYDRANT
INV	INVERT
LB	LEACH BASIN
LP	LIGHT POLE
MH	MANHOLE
MW	MONITORING WELL
OHW	OVERHEAD WIRE
PVC	POLYVINYLCHLORIDE PIPE
PWW	PAVED WATER WAY
RCP	REINFORCED CONCRETE PIPE
SMH	SEWER MANHOLE
TSV&B	TAPPING SLEEVE VALVE & BOX
UP	UTILITY POLE
WG	WATER GATE
WIP	WROUGHT IRON PIPE
WM	WATER METER/WATER MAIN

ALIGNMENT & GRADING ABBREVIATIONS

CC	CENTER OF CURVE
HP	HIGH POINT
I.T.	INTERSECTION OF TANGENT
LP	LOW POINT
PC	POINT OF CURVATURE
PCC	POINT OF COMPOUND CURVATURE
PI	POINT OF INTERSECTION
PNT	POINT
POC	POINT ON CURVE
POT	POINT ON TANGENT
PRC	POINT OF REVERSE CURVATURE
PT	POINT OF TANGENCY
LPT	ANGLE POINT
R	RADIUS OF CURVATURE
T	TANGENT DISTANCE OF CURVE
TAN	TANGENT
25.45	SPOT ELEVATION

PROFILE ABBREVIATIONS

AD	ALGEBRAIC DIFFERENCE IN RATES OF GRADE
HSD	HORIZONTAL SIGHT DISTANCE
K	RATE OF VERTICAL CURVATURE
L	LENGTH OF CURVE
PVC	POINT OF VERTICAL CURVATURE
PVCC	POINT OF VERTICAL COMPOUND CURVATURE
PVI	POINT OF VERTICAL INTERSECTION
PVRC	POINT OF VERTICAL REVERSE CURVATURE
PVT	POINT OF VERTICAL TANGENCY
SSD	STOPPING SIGHT DISTANCE
VC	VERTICAL CURVE

TRAFFIC SIGNAL

CAB.	CABINET
CCVE	CLOSED CIRCUIT VIDEO EQUIPMENT
DW	STEADY DON'T WALK
FDW	FLASHING DON'T WALK
FR	FLASHING CIRCULAR RED
← FR	FLASHING RED LEFT ARROW
→ FR	FLASHING RED RIGHT ARROW
FY	FLASHING CIRCULAR YELLOW
← FY	FLASHING YELLOW LEFT ARROW
→ FY	FLASHING YELLOW RIGHT ARROW
G	STEADY CIRCULAR GREEN
← G	STEADY GREEN LEFT ARROW
→ G	STEADY GREEN RIGHT ARROW
GSL	STEADY GREEN SLASH LEFT ARROW
GSR	STEADY GREEN SLASH RIGHT ARROW
G	STEADY GREEN VERTICAL ARROW
OL	OVERLAP
PEP	PEDESTRIAN
PTZ	PAN, TILT, ZOOM
R	STEADY CIRCULAR RED
← R	STEADY RED LEFT ARROW
→ R	STEADY RED RIGHT ARROW
TR SIG	TRAFFIC SIGNAL
TSC	TRAFFIC SIGNAL CONDUIT
W	STEADY WALK
Y	STEADY CIRCULAR YELLOW
← Y	STEADY YELLOW LEFT ARROW
→ Y	STEADY YELLOW RIGHT ARROW

SUBBURY BRUCE FREEMAN RAIL TRAIL			
STATE	FED. AID PROJ. NO.	SHEET NO.	TOTAL SHEETS
MA	XXX-XXXX(XXX)X	2	319
PROJECT FILE NO.		608164	

GENERAL NOTES

GENERAL NOTES:

- EXISTING CONDITIONS AND TOPOGRAPHICAL INFORMATION FROM AN ACTUAL FIELD SURVEY CONDUCTED BY VHB, INC. IN DECEMBER 2015 THROUGH APRIL 2016. SUPPLEMENTARY FIELD SURVEY WAS CONDUCTED BY GCG ASSOCIATES FROM NOVEMBER 2020 THROUGH DECEMBER 2020.
- THE HORIZONTAL CONTROL IS BASED ON THE MASSACHUSETTS MAINLAND STATE PLANE COORDINATE SYSTEM AND THE NATIONAL GEODETIC SURVEY (NAD83). ALL ELEVATION IS US FEET, REFERENCED TO THE NORTH AMERICAN VERTICAL DATUM OF 1988 (NAV88).
- THE CONTRACTOR SHALL VERIFY ALL EXISTING DIMENSIONS AND GRADES IN THE FIELD BEFORE COMMENCING WORK AND PROMPTLY NOTIFY THE ENGINEER OF ANY DISCREPANCIES.
- INFORMATION REGARDING THE LOCATION OF EXISTING UTILITIES HAS BEEN BASED UPON AVAILABLE INFORMATION AND MAY BE INCOMPLETE, AND WHERE SHOWN SHOULD BE CONSIDERED APPROXIMATE. NO GUARANTEE TO THE ACCURACY OF THE EXISTING UTILITIES FACILITIES SHOWN IN THIS PROJECT IS EXPRESSED OR IMPLIED UNLESS OTHERWISE NOTED. CONTRACTOR SHALL CONTACT "Mass DIG-SAFE", 1-888-344-7233. CONTRACTOR SHALL MAINTAIN MARKINGS WHERE NEEDED DURING PROJECT. ALL UTILITY LOCATIONS THAT DO NOT MATCH THE VERTICAL OR HORIZONTAL CONTROL SHOWN ON THE PLANS SHALL IMMEDIATELY BE BROUGHT TO THE ATTENTION OF THE ENGINEER FOR RESOLUTION. THE CONTRACTOR SHALL VERIFY LOCATIONS OF UTILITIES AND SERVICE LATERALS PRIOR TO CONSTRUCTION. ANY CONFLICTS WITH LOCATIONS OF LIGHT POLES, TREES, ETC. SHALL BE BROUGHT TO THE ATTENTION OF THE ENGINEER FOR RESOLUTION PRIOR TO CONSTRUCTION.
- DRAINAGE ELEVATIONS ARE PROVIDED FOR DESIGN PURPOSES ONLY. THE CONTRACTOR SHALL VERIFY BY TEST PIT, THE LOCATIONS OF EXISTING UTILITIES WHICH MAY CONFLICT WITH THE PROPOSED DRAINAGE DESIGN. ANY FIELD ADJUSTMENTS REQUIRED WILL BE MADE AS APPROVED OR DIRECTED BY THE ENGINEER. ONLY AFTER THE CONTRACTOR VERIFIES ELEVATIONS FOR THE CONSTRUCTABILITY OF THE DRAINAGE SYSTEM SHALL ANY STRUCTURES BE ORDERED. ANY FIELD ADJUSTMENTS TO LINE & GRADE UP TO A DEPTH OF 5' SHALL BE INCLUDED IN THE COST OF THE PIPE. PIPE EXCAVATION GREATER THAN 5' WILL BE PAID UNDER CLASS B TRENCH EXCAVATION.
- THE CONTRACTOR SHALL VERIFY BY TEST PIT, THE LOCATIONS OF EXISTING UTILITIES WHICH MAY CONFLICT WITH PROPOSED CONDUIT AND SIGNAL EQUIPMENT. ANY FIELD ADJUSTMENTS REQUIRED WILL BE MADE AS APPROVED OR DIRECTED BY THE ENGINEER.
- WHERE AN EXISTING UTILITY IS FOUND TO CONFLICT WITH THE PROPOSED WORK, THE LOCATION, ELEVATION AND SIZE OF THE UTILITY SHALL BE ACCURATELY DETERMINED WITHOUT DELAY BY THE CONTRACTOR, AND THE INFORMATION FURNISHED TO THE ENGINEER FOR RESOLUTION OF THE CONFLICT.
- THE CONTRACTOR SHALL ALTER THE MASONRY OF THE TOP SECTION OF ALL EXISTING DRAINAGE AND SEWER STRUCTURES AS NECESSARY FOR CHANGES IN GRADE, AND RESET ALL WATER AND DRAINAGE FRAMES, GRATES AND BOXES TO THE PROPOSED FINISH SURFACE GRADE. REQUIRED NEW MASONRY SHALL BE CLAY BRICK.
- THE CONTRACTOR SHALL MAKE ALL ARRANGEMENTS FOR THE ALTERATION AND ADJUSTMENT OF GAS, ELECTRIC, TELEPHONE AND ANY OTHER PRIVATE UTILITIES BY THE UTILITY COMPANIES.
- EXISTING UTILITY POLES WILL BE RELOCATED BY OTHERS IF REQUIRED.
- PRIOR TO ONSET OF TREE REMOVAL ACTIVITIES, THE CONTRACTOR, RESIDENT ENGINEER AND MASSDOT LANDSCAPE ARCHITECT AND TOWN REPRESENTATIVE SHALL WALK SITE TO IDENTIFY TREES TO BE REMOVED.
- AREAS OUTSIDE THE LIMITS OF PROPOSED WORK DISTURBED BY THE CONTRACTOR'S OPERATIONS SHALL BE RESTORED BY THE CONTRACTOR TO THEIR ORIGINAL CONDITION AT NO EXPENSE TO THE OWNER.
- THE TERM "PROPOSED" (PROP) MEANS WORK TO BE CONSTRUCTED USING NEW MATERIALS OR, WHERE APPLICABLE, RE-USING EXISTING MATERIALS IDENTIFIED AS "REMOVE AND RESET" (R&R).
- JOINTS BETWEEN NEW ASPHALT CONCRETE ROADWAY PAVEMENT AND SAWCUT EXISTING PAVEMENT SHALL BE SEALED WITH BITUMEN AND BACKSANDS.
- AFTER MILLING OPERATIONS AND PRIOR TO PAVING THE SUPERPAVE INTERMEDIATE OR SURFACES COURSES THE ENGINEER SHALL EVALUATE THE MILLED SURFACE AND SHALL APPLY THE APPROPRIATE REPAIR METHOD IF REQUIRED.
- EXISTING SIGNS WITHIN THE PROJECT LIMITS SHALL BE RETAINED UNLESS INDICATED OTHERWISE ON THE DRAWINGS.
- IF SUITABLE, ALL EXISTING GRANITE CURB & EDGING SHALL BE RE-USED IN THE PROPOSED WORK, EXCEPT CURVED STONES OF A DIFFERENT RADIUS THAN PROPOSED CURB.
- ALL PROPOSED HOT MIX ASPHALT CURB SHALL BE MASSDOT TYPE 3.
- ALL EXISTING STATE, COUNTY, CITY, AND TOWN LOCATION LINES AND PRIVATE PROPERTY LINES HAVE BEEN ESTABLISHED FROM AVAILABLE INFORMATION AND THEIR EXACT LOCATIONS ARE NOT GUARANTEED.
- ALL PROPOSED BOUNDS SHALL BE PLACED BY A LICENSED PROFESSIONAL SURVEYOR. THE CONTRACTOR SHALL EXERCISE DUE CARE WHEN WORKING AROUND ALL PROPERTY BOUNDS WHICH ARE TO REMAIN. SHOULD ANY DAMAGE TO A BOUND RESULT FROM THE ACTIONS OF THE CONTRACTOR, THE CONTRACTOR SHALL HAVE THE BOUND REPLACED AND/OR REALIGNED BY A LICENSED PROFESSIONAL SURVEYOR AS DIRECTED BY THE ENGINEER AT NO ADDITIONAL COST.
- DISPOSAL OF ALL SURPLUS MATERIAL SHALL BE AS APPROVED BY THE ENGINEER AND OWNER.
- LATERAL DRAIN PIPES SHALL BE INSTALLED WITH A PITCH OF 0.01 FOOT PER FOOT (MINIMUM) UNLESS NOTED OTHERWISE ON THE PLANS.

GENERAL SYMBOLS

EXISTING	PROPOSED	DESCRIPTION
		JERSEY BARRIER
		CATCH BASIN
		CATCH BASIN CURB INLET
		FLAG POLE
		GAS PUMP
		MAIL BOX
		POST SQUARE
		POST CIRCULAR
		WELL
		ELECTRIC HANDHOLE
		FENCE GATE POST
		GAS GATE
		BORING HOLE
		MONITORING WELL
		TEST PIT
		HYDRANT
		LIGHT POLE
		COUNTY BOUND
		GPS POINT
		CABLE MANHOLE
		DRAINAGE MANHOLE
		ELECTRIC MANHOLE
		GAS MANHOLE
		MISC MANHOLE
		SEWER MANHOLE
		TELEPHONE MANHOLE
		WATER MANHOLE
		MASSACHUSETTS HIGHWAY BOUND
		MONUMENT
		STONE BOUND
		TOWN OR CITY BOUND
		TRAVERSE OR TRIANGULATION STATION
		TROLLEY POLE OR GUY POLE
		TRANSMISSION POLE
		UTILITY POLE W/ FIREBOX
		UTILITY POLE WITH DOUBLE LIGHT
		UTILITY POLE W / 1 LIGHT
		UTILITY POLE
		BUSH
		TREE
		STUMP
		SWAMP / MARSH
		WATER GATE
		PARKING METER
		OVERHEAD CABLE/WIRE
		CURBING
		CONTOURS (ON-THE-GROUND SURVEY DATA)
		CONTOURS (PHOTOGRAMMETRIC DATA)
		UNDERGROUND DRAIN PIPE (DOUBLE LINE 24 INCH AND OVER)
		UNDERGROUND ELECTRIC DUCT (DOUBLE LINE 24 INCH AND OVER)
		UNDERGROUND GAS MAIN (DOUBLE LINE 24 INCH AND OVER)
		UNDERGROUND SEWER MAIN (DOUBLE LINE 24 INCH AND OVER)
		UNDERGROUND TELEPHONE DUCT (DOUBLE LINE 24 INCH AND OVER)
		UNDERGROUND WATER MAIN (DOUBLE LINE 24 INCH AND OVER)
		BALANCED STONE WALL
		GUARD RAIL - STEEL POSTS
		GUARD RAIL - WOOD POSTS
		CHAIN LINK OR METAL FENCE
		WOOD FENCE
		EROSION CONTROL
		DRAINAGE SWALE
		TREE LINE
		SAWCUT LINE
		TOP OR BOTTOM OF SLOPE
		LIMIT OF EDGE OF PAVEMENT OR COLD PLANE AND OVERLAY
		BANK OF RIVER OR STREAM
		BORDER OF WETLAND
		100 FT WETLAND BUFFER
		200 FT RIVERFRONT BUFFER
		STATE HIGHWAY LAYOUT
		TOWN OR CITY LAYOUT
		COUNTY LAYOUT
		RAILROAD SIDELINE
		TOWN OR CITY BOUNDARY LINE
		PROPERTY LINE OR APPROXIMATE PROPERTY LINE
		EASEMENT

TRAFFIC SYMBOLS

EXISTING	PROPOSED	DESCRIPTION
		CONTROLLER PHASE ACTUATED
		TRAFFIC SIGNAL HEAD (SIZE AS NOTED)
		WIRE LOOP DETECTOR (6' x 6' TYP UNLESS OTHERWISE SPECIFIED)
		VIDEO DETECTION CAMERA
		MICROWAVE DETECTOR
		PEDESTRIAN PUSH BUTTON, SIGN (DIRECTIONAL ARROW AS SHOWN) AND SADDLE
		EMERGENCY PREEMPTION CONFIRMATION STROBE LIGHT
		VEHICULAR SIGNAL HEAD
		VEHICULAR SIGNAL HEAD, OPTICALLY PROGRAMMED
		FLASHING BEACON
		PEDESTRIAN SIGNAL HEAD, (TYPE AS NOTED OR AS SPECIFIED)
		RAILROAD SIGNAL
		SIGNAL POST AND BASE (ALPHA-NUMERIC DESIGNATION NOTED)
		MAST ARM, SHAFT AND BASE (ARM LENGTH AS NOTED)
		HIGH MAST POLE OR TOWER
		SIGN AND POST
		SIGN AND POST (2 POSTS)
		MAST ARM WITH LUMINAIRE
		OPTICAL PRE-EMPTION DETECTOR
		CONTROL CABINET, GROUND MOUNTED
		CONTROL CABINET, POLE MOUNTED
		FLASHING BEACON CONTROL AND METER PEDESTAL
		LOAD CENTER ASSEMBLY
		PULL BOX 12"x12" (OR AS NOTED)
		ELECTRIC HANDHOLE 12"x24" (OR AS NOTED)
		TRAFFIC SIGNAL CONDUIT

PAVEMENT MARKINGS SYMBOLS

EXISTING	PROPOSED	DESCRIPTION
		PAVEMENT ARROW - WHITE
		LEGEND "ONLY" - WHITE
		STOP LINE
		CROSSWALK
		SOLID WHITE LINE
		SOLID YELLOW LINE
		BROKEN WHITE LINE
		BROKEN YELLOW LINE
		DOTTED WHITE LINE
		DOTTED YELLOW LINE
		DOTTED WHITE LINE EXTENSION
		DOTTED YELLOW LINE EXTENSION
		DOUBLE WHITE LINE
		DOUBLE YELLOW LINE
		LONG DASHED YELLOW LINE

**SUBURRY
BRUCE FREEMAN RAIL TRAIL**

STATE	FED AID PROJ. NO.	SHEET NO.	TOTAL SHEETS
MA	XXX-XXX(XXX)X	4	319
PROJECT FILE NO.		608164	

KEY PLAN & BORING LOCATIONS

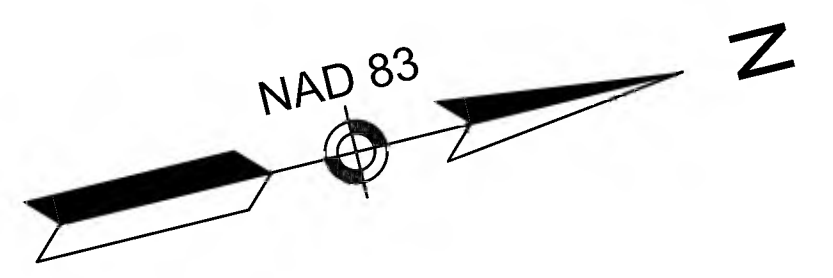

BEGINNING OF PROJECT
PROJ. NO. 608164
STA. 101+00.00
N 2957500.7922
E 677093.1169

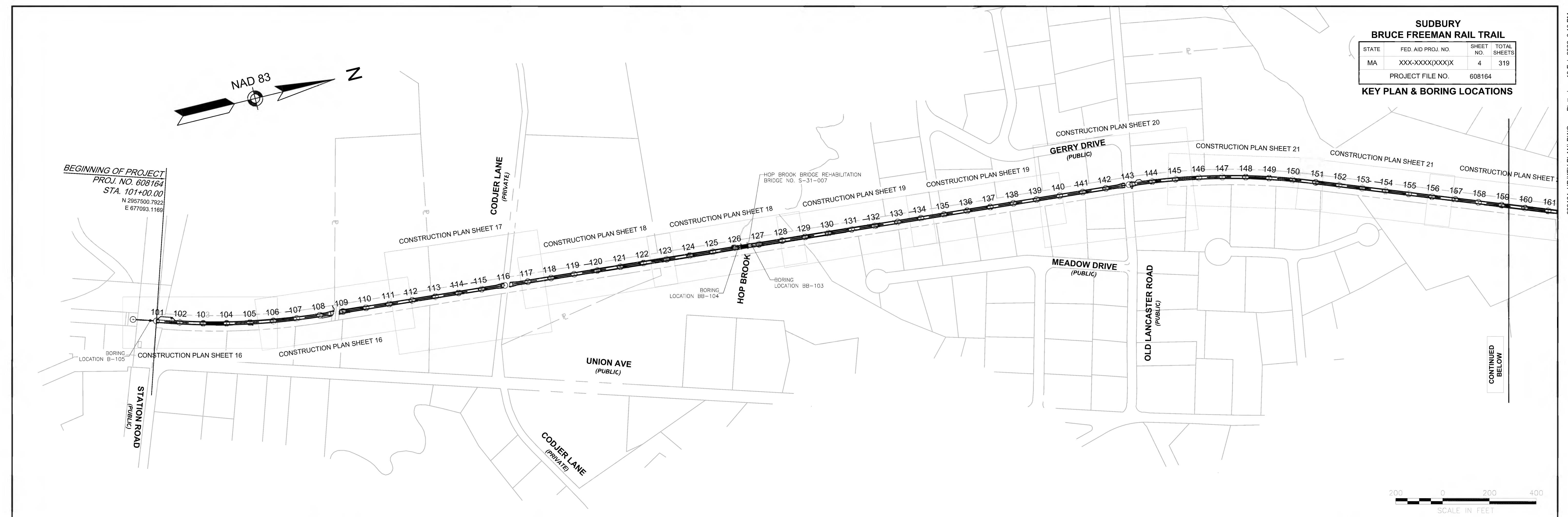

CONTINUED BELOW

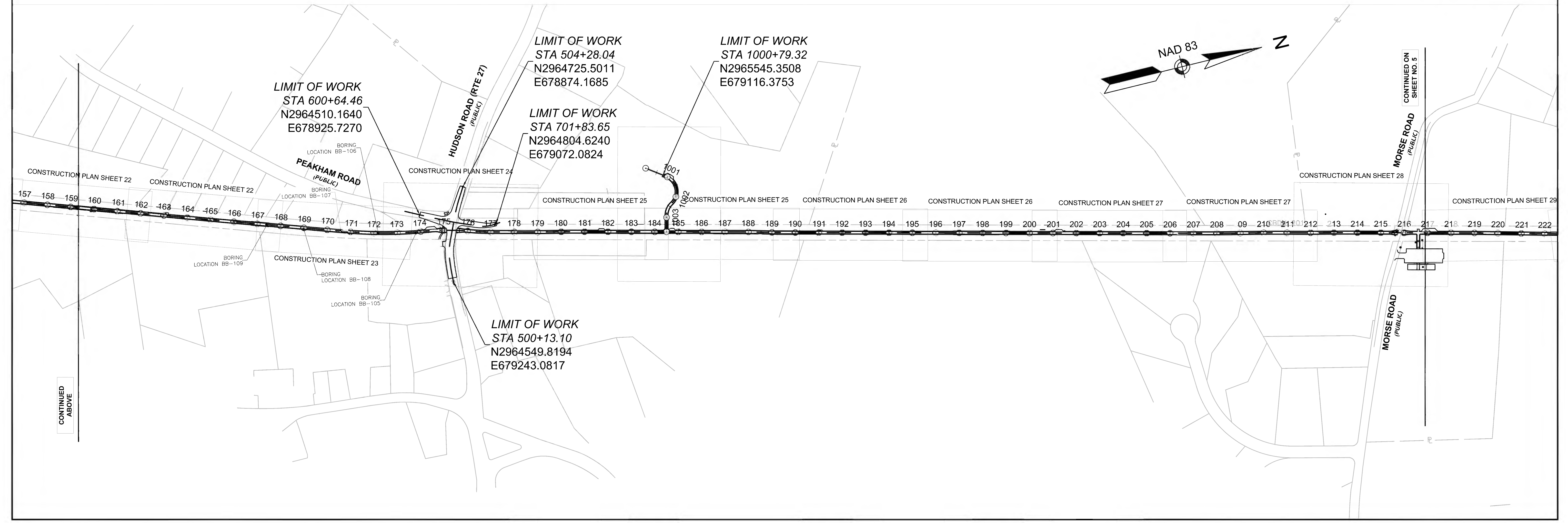
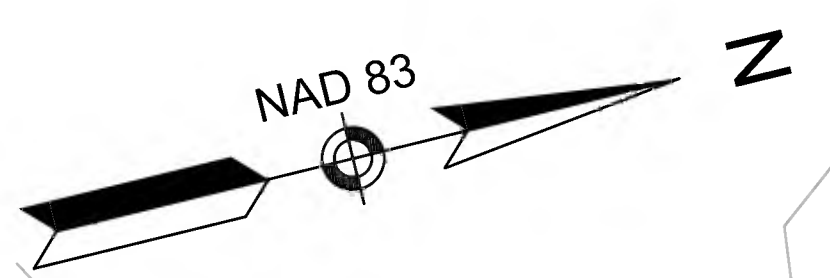

CONTINUED ABOVE

CONTINUED ON SHEET NO. 5

**SUBURBY
BRUCE FREEMAN RAIL TRAIL**

STATE	FED AID PROJ. NO.	SHEET NO.	TOTAL SHEETS
MA	XXX-XXX(XXX)X	5	319
PROJECT FILE NO.		608164	

KEY PLAN & BORING LOCATIONS

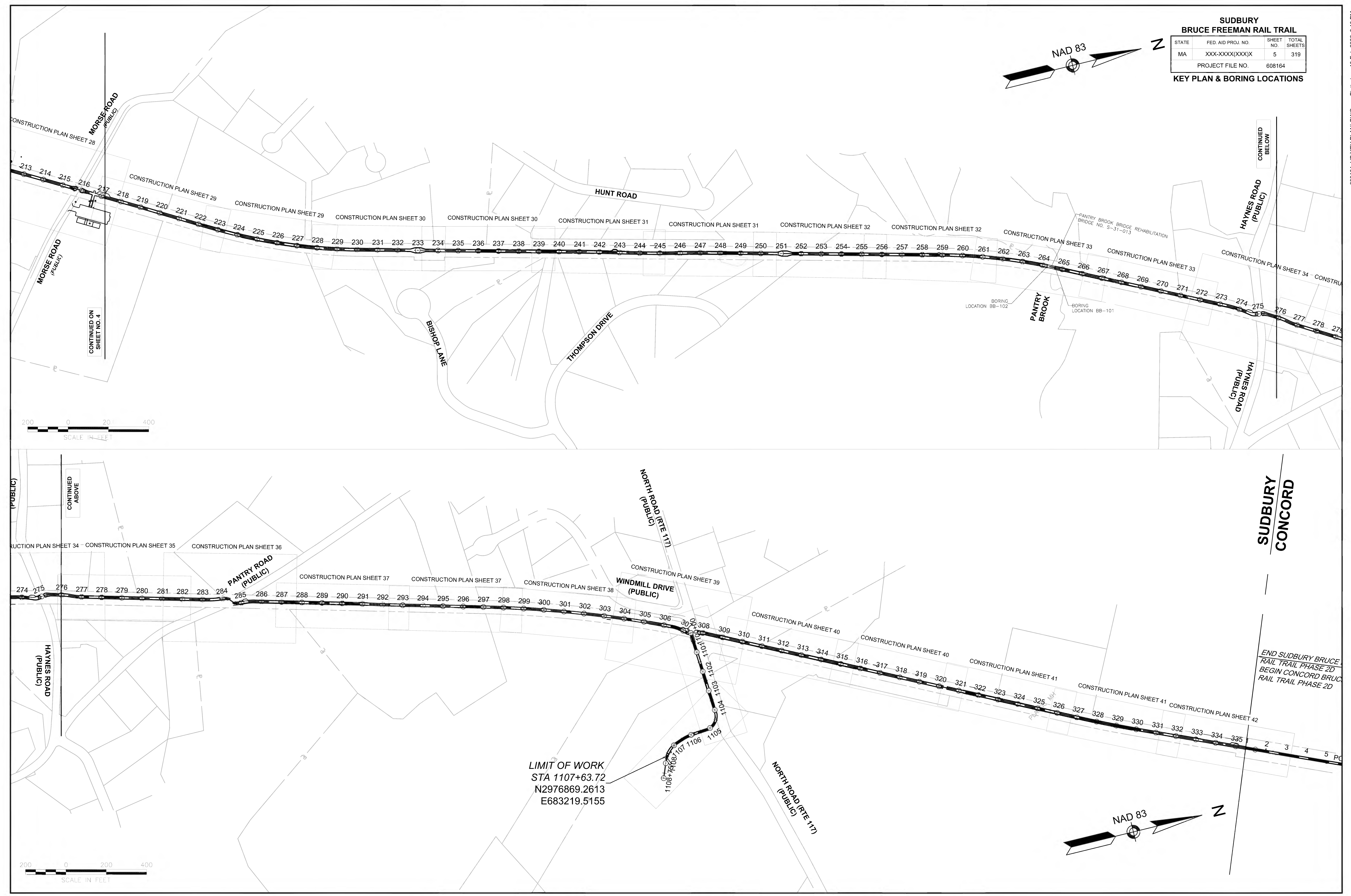
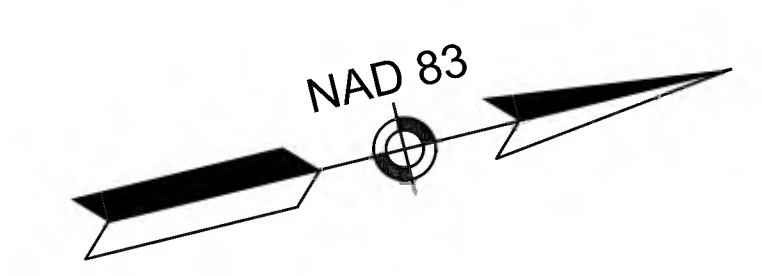

LIMIT OF WORK
 STA 1107+63.72
 N2976869.2613
 E683219.5155

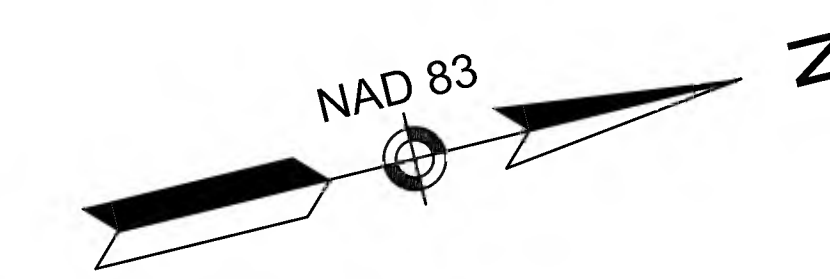

**SUBURBY
CONCORD**

END SUBURBY BRUCE
 RAIL TRAIL PHASE 2D
 BEGIN CONCORD BRUCE
 RAIL TRAIL PHASE 2D

SUBURRY BRUCE FREEMAN RAIL TRAIL			
STATE	FED. AID PROJ. NO.	SHEET NO.	TOTAL SHEETS
MA	XXX-XXX(XXX)X	10	319
PROJECT FILE NO.		608164	

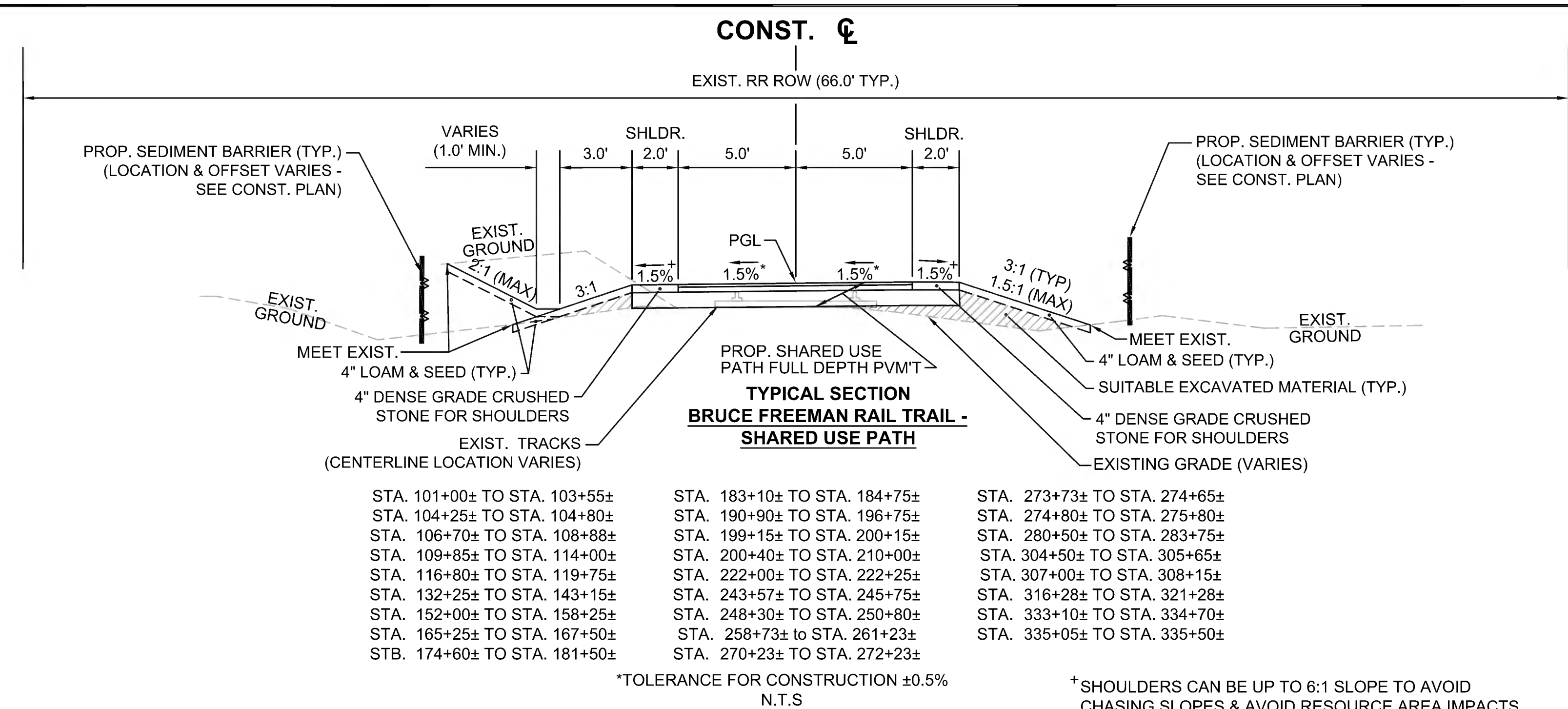

Station Range	Station Range	Station Range
STA. 101+00± TO STA. 103+55±	STA. 183+10± TO STA. 184+75±	STA. 273+73± TO STA. 274+65±
STA. 104+25± TO STA. 104+80±	STA. 190+90± TO STA. 196+75±	STA. 274+80± TO STA. 275+80±
STA. 106+70± TO STA. 108+88±	STA. 199+15± TO STA. 200+15±	STA. 280+50± TO STA. 283+75±
STA. 109+85± TO STA. 114+00±	STA. 200+40± TO STA. 210+00±	STA. 304+50± TO STA. 305+65±
STA. 116+80± TO STA. 119+75±	STA. 222+00± TO STA. 222+25±	STA. 307+00± TO STA. 308+15±
STA. 132+25± TO STA. 143+15±	STA. 243+57± TO STA. 245+75±	STA. 316+28± TO STA. 321+28±
STA. 152+00± TO STA. 158+25±	STA. 248+30± TO STA. 250+80±	STA. 333+10± TO STA. 334+70±
STA. 165+25± TO STA. 167+50±	STA. 258+73± TO STA. 261+23±	STA. 335+05± TO STA. 335+50±
STB. 174+60± TO STA. 181+50±	STA. 270+23± TO STA. 272+23±	

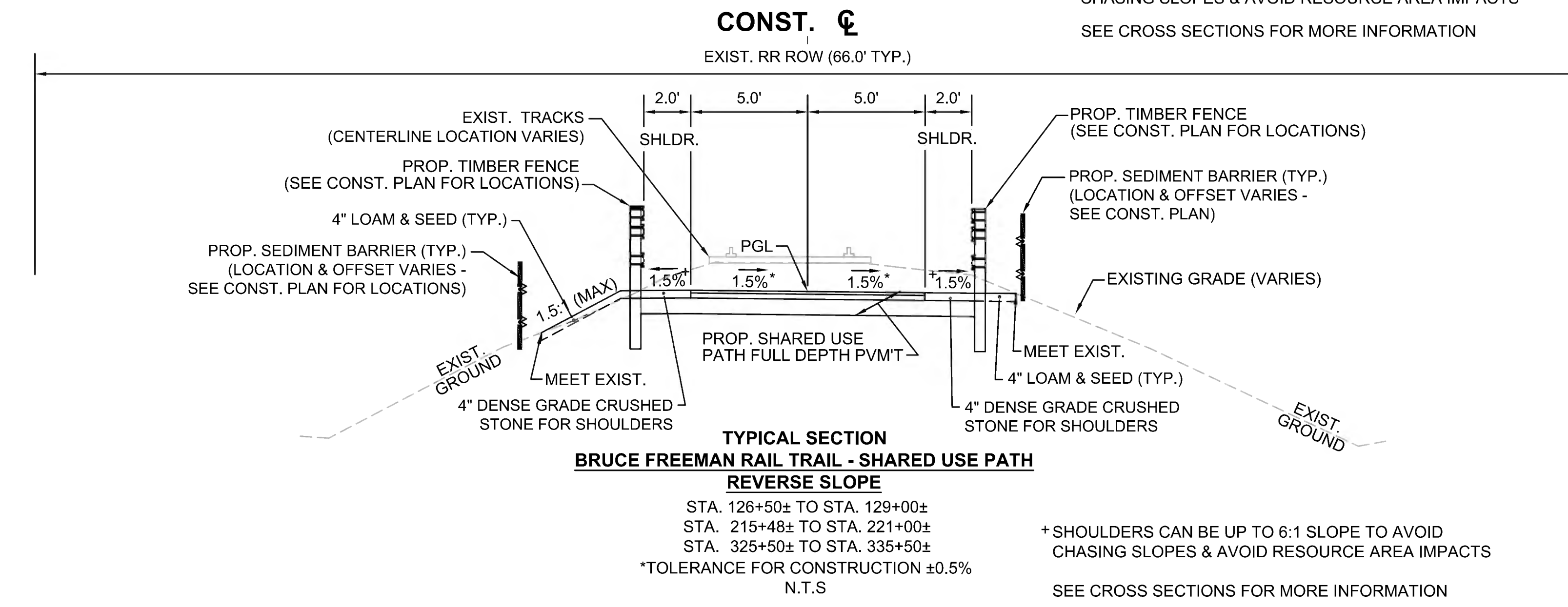

Station Range	Station Range	Station Range
STA. 126+50± TO STA. 129+00±	STA. 215+48± TO STA. 221+00±	STA. 325+50± TO STA. 335+50±

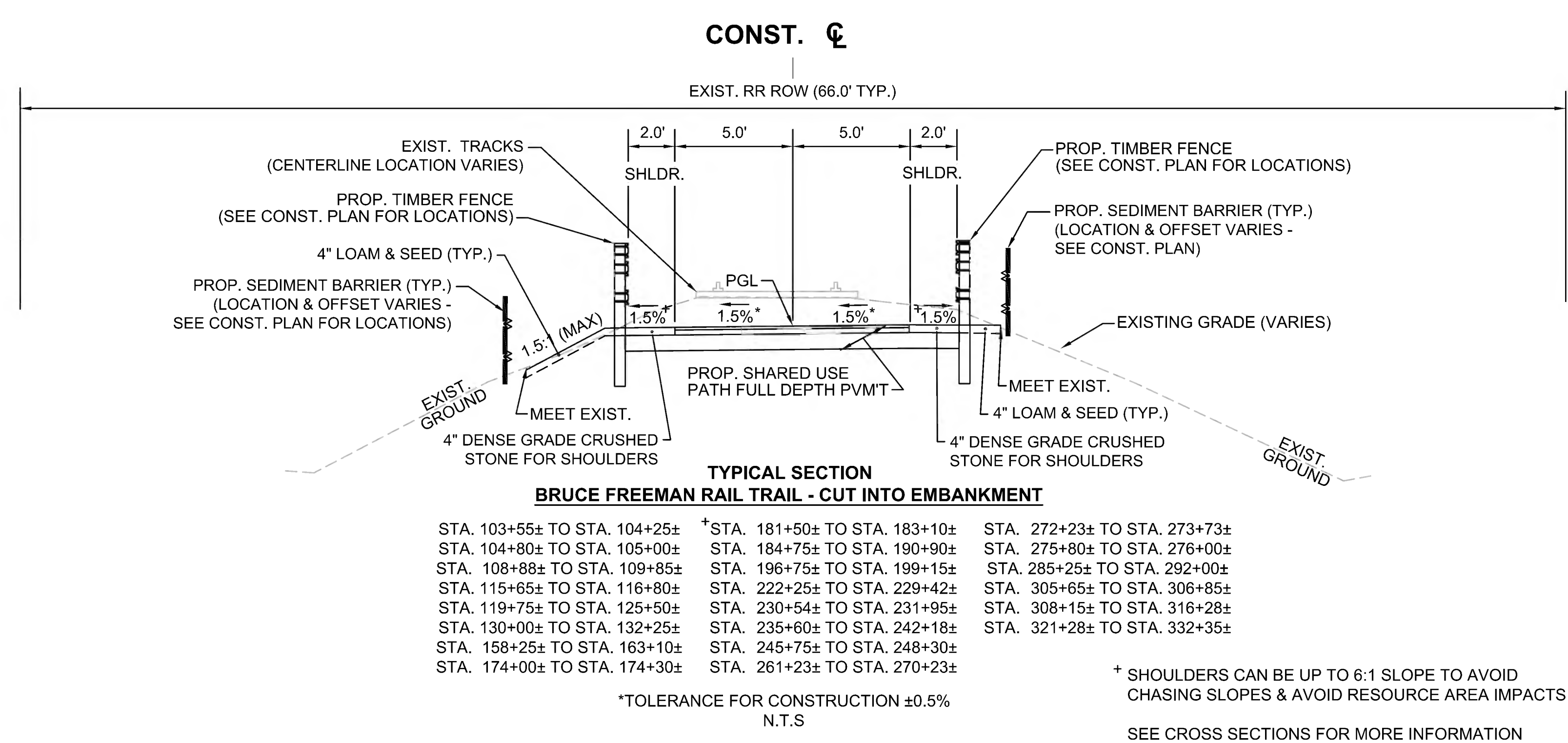

Station Range	Station Range	Station Range
STA. 103+55± TO STA. 104+25±	STA. 181+50± TO STA. 183+10±	STA. 272+23± TO STA. 273+73±
STA. 104+80± TO STA. 105+00±	STA. 184+75± TO STA. 190+90±	STA. 275+80± TO STA. 276+00±
STA. 108+88± TO STA. 109+85±	STA. 196+75± TO STA. 199+15±	STA. 285+25± TO STA. 292+00±
STA. 115+65± TO STA. 116+80±	STA. 222+25± TO STA. 229+42±	STA. 305+65± TO STA. 306+85±
STA. 119+75± TO STA. 125+50±	STA. 230+54± TO STA. 231+95±	STA. 308+15± TO STA. 316+28±
STA. 130+00± TO STA. 132+25±	STA. 235+60± TO STA. 242+18±	STA. 321+28± TO STA. 332+35±
STA. 158+25± TO STA. 163+10±	STA. 245+75± TO STA. 248+30±	
STA. 174+00± TO STA. 174+30±	STA. 261+23± TO STA. 270+23±	

PAVEMENT NOTES:

- PROPOSED SHARED-USE PATH**
 - SURFACE:** 1-1/2" SUPERPAVE SURFACE COURSE - 9.5 (SSC - 9.5)
 - INTERMEDIATE:** 2-1/2" SUPERPAVE INTERMEDIATE COURSE - 19.0 (SIC - 19.0)
 - SUBBASE:** 4" to 8" GRAVEL BORROW, TYPE b (FOR LEVELING) OVER RESHAPED EXISTING RAILROAD BALLAST
- PROPOSED PARKING LOT FULL DEPTH PAVEMENT**
 - SURFACE:** 1-1/2" SUPERPAVE SURFACE COURSE - POLYMER (SSC - 12.5 - P) - OVER
 - BASE:** 2-1/2" SUPERPAVE INTERMEDIATE COURSE (SIC - 19.0) - OVER
 - FOUNDATION:** 8" GRAVEL BORROW, TYPE b
- PROPOSED FULL DEPTH CONSTRUCTION (LESS THAN 4.00' WIDE) - PEAKHAM ROAD & HUDSON ROAD**
 - SURFACE:** 1-3/4" SUPERPAVE SURFACE COURSE - POLYMER (SSC - 12.5 - P) - OVER
 - INTERMEDIATE:** 2-1/2" SUPERPAVE INTERMEDIATE COURSE (SIC - 19.0) - OVER
 - BASE:** 6" HIGH EARLY STRENGTH CEMENT CONCRETE BASE COURSE 4000psi, 610, 3/4" OVER
 - SUBBASE:** 8" GRAVEL BORROW, TYPE b.
- PROPOSED PAVEMENT MILLING & OVERLAY - PEAKHAM ROAD & HUDSON ROAD**
 - 1-3/4" PAVEMENT MILLING**
 - 1-3/4" SUPERPAVE SURFACE COURSE - POLYMER (SSC - 12.5 - P)**
- PROPOSED HOT MIX ASPHALT SIDEWALK & DRIVEWAY**
 - SURFACE:** 1-1/2" SUPERPAVE SURFACE COURSE (SIC - 9.5) - OVER 2-1/2" SUPERPAVE INTERMEDIATE COURSE (SIC - 12.5)
 - FOUNDATION:** 8" GRAVEL BORROW, TYPE b
- PROPOSED CEMENT CONCRETE WALK, REST AREA & WHEELCHAIR RAMP**
 - SURFACE:** 4" CEMENT CONCRETE AIR ENTRAINED 4000 PSI, 3/4", 610
 - SUBBASE:** 8" GRAVEL BORROW, TYPE b

NOTES: EXIST. GRAVEL/BALLAST SUBGROUND MATERIAL DETERMINED BY THE ENGINEER TO BE SUITABLE SHALL REMAIN. THE DEPTH OF THE GRAVEL BORROW WILL BE AS REQUIRED BASED ON THE PROPOSED SUB-BASE ELEVATIONS.

AFTER REMOVAL OF STEEL RAILS AND WOOD TIMBER, ROUGH GRADE AND COMPACT SUBGROUND AREA. THEN PLACE AND COMPACT GRAVEL BORROW SUB-BASE MATERIAL IN MULTIPLE LIFTS.

ASPHALT EMULSION FOR TACK COAT AND HMA JOINT SEALANT SHALL BE APPLIED PER SECTION 450 QA OF THE SPECIAL PROVISIONS.

HMA FOR PATCHING SHALL BE USED FOR ALL PERMANENT, PARTIAL, AND FULL DEPTH PAVEMENT REPAIRS OF UNSOUND PAVEMENT PER SECTION 450 IN AREAS OUTSIDE OF PROP. OSED FULL DEPTH RECLAMATION OR RECONSTRUCTION ROADWAY AREAS.

HMA FOR MISCELLANEOUS WORK SHALL BE USED FOR ALL TEMPORARY CONSTRUCTION, TAPER RAMPS, CURB CUT RAMPS, TEMPORARY TRENCH REPAIR, ETC.

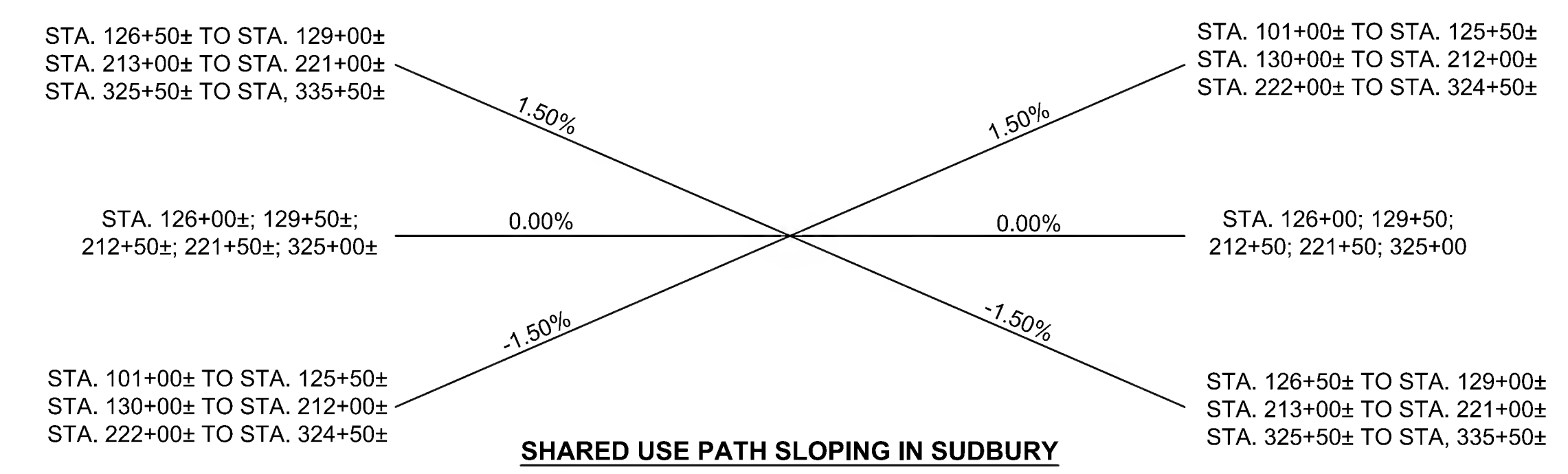

NOTE:
1. THE SECTIONS OF PROPOSED ROADWAY NOT COVERED IN THE RANGE OF STATIONS ASSOCIATED WITH THE TYPICAL SECTIONS ARE EITHER IN TRANSITION OR ARE LOCATED AT INTERSECTIONS AND THEREFOR HAVE NOT BEEN SHOWN. REFER TO CROSS SECTION SHEETS FOR MORE DETAILS.

NOTES:

- MATTING FOR EROSION CONTROL SHALL BE INSTALLED ON EXISTING SIDE SLOPES THAT ARE 2:1 OR STEEPER THAT ARE NOT WITHIN JUTE MESH WATERWAY AREAS.
- MODIFIED ROCK FILL SHALL BE USED AS NEEDED ON ANY CUT OR FILL SLOPES STEEPER THAN 2:1 WHERE POOR SOIL CONDITIONS EXIST AND MATTING FOR EROSION CONTROL IS DEEMED INADEQUATE AS DIRECTED BY THE ENGINEER.

SUBURRY BRUCE FREEMAN RAIL TRAIL			
STATE	FED. AID PROJ. NO.	SHEET NO.	TOTAL SHEETS
MA	XXX-XXX(XXX)X	11	319
PROJECT FILE NO.		608164	

TYPICAL SECTIONS

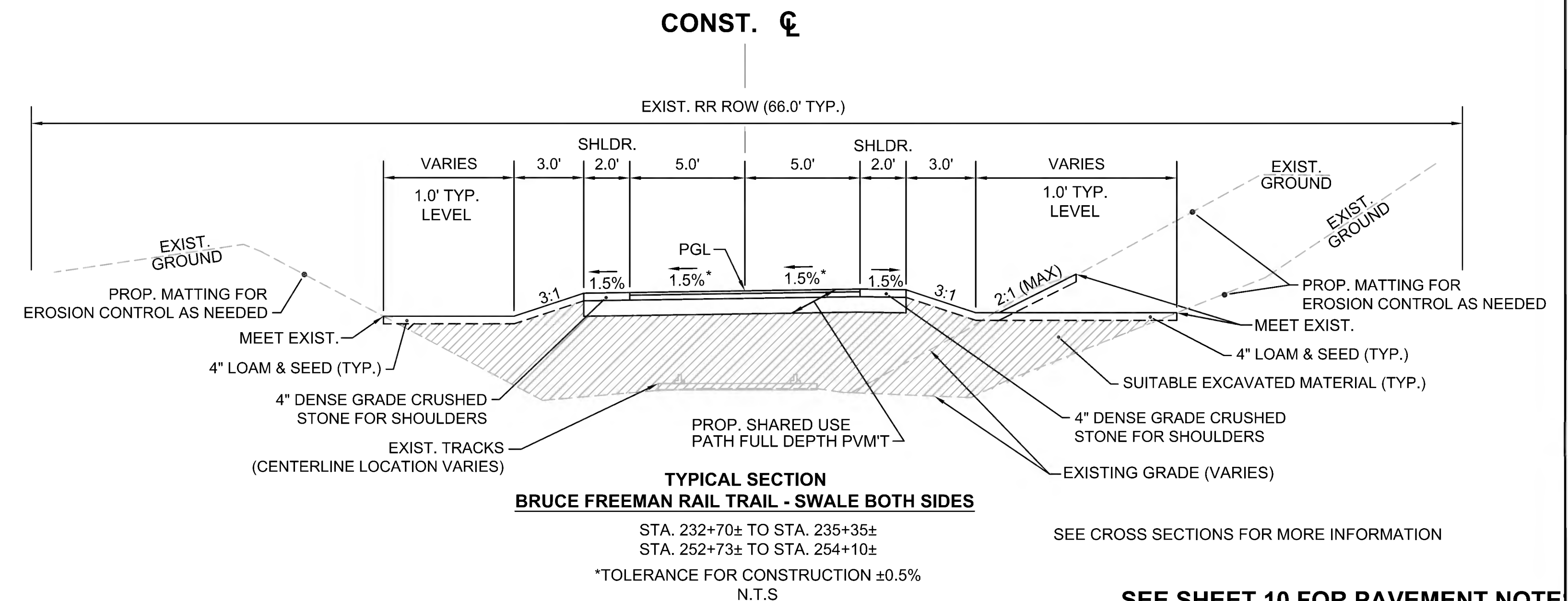
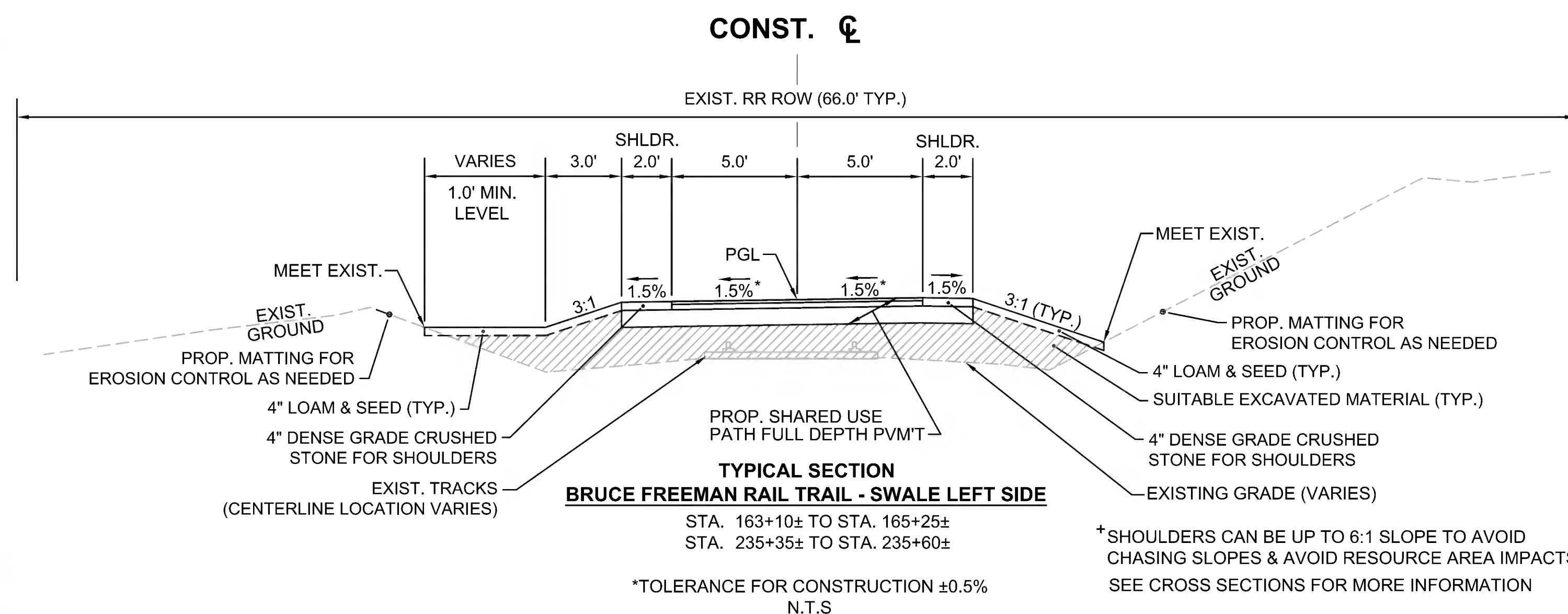
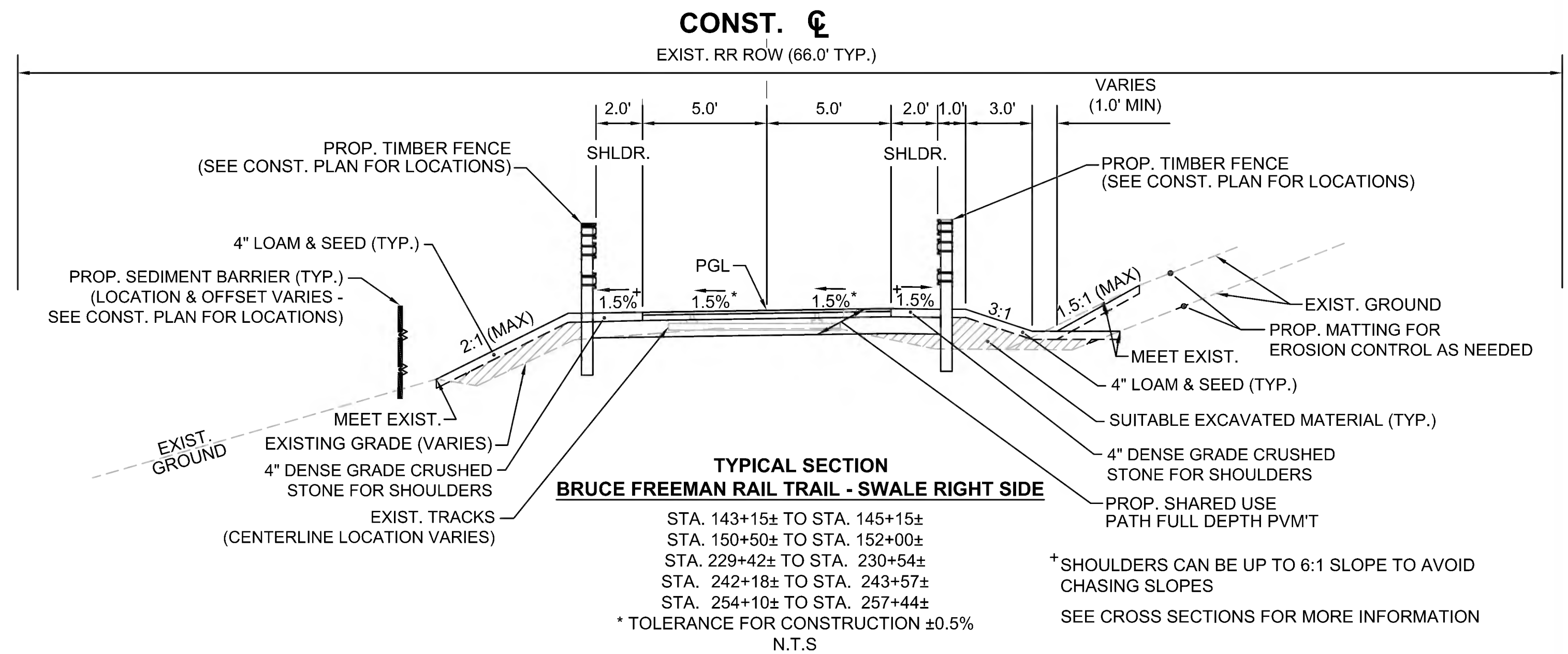
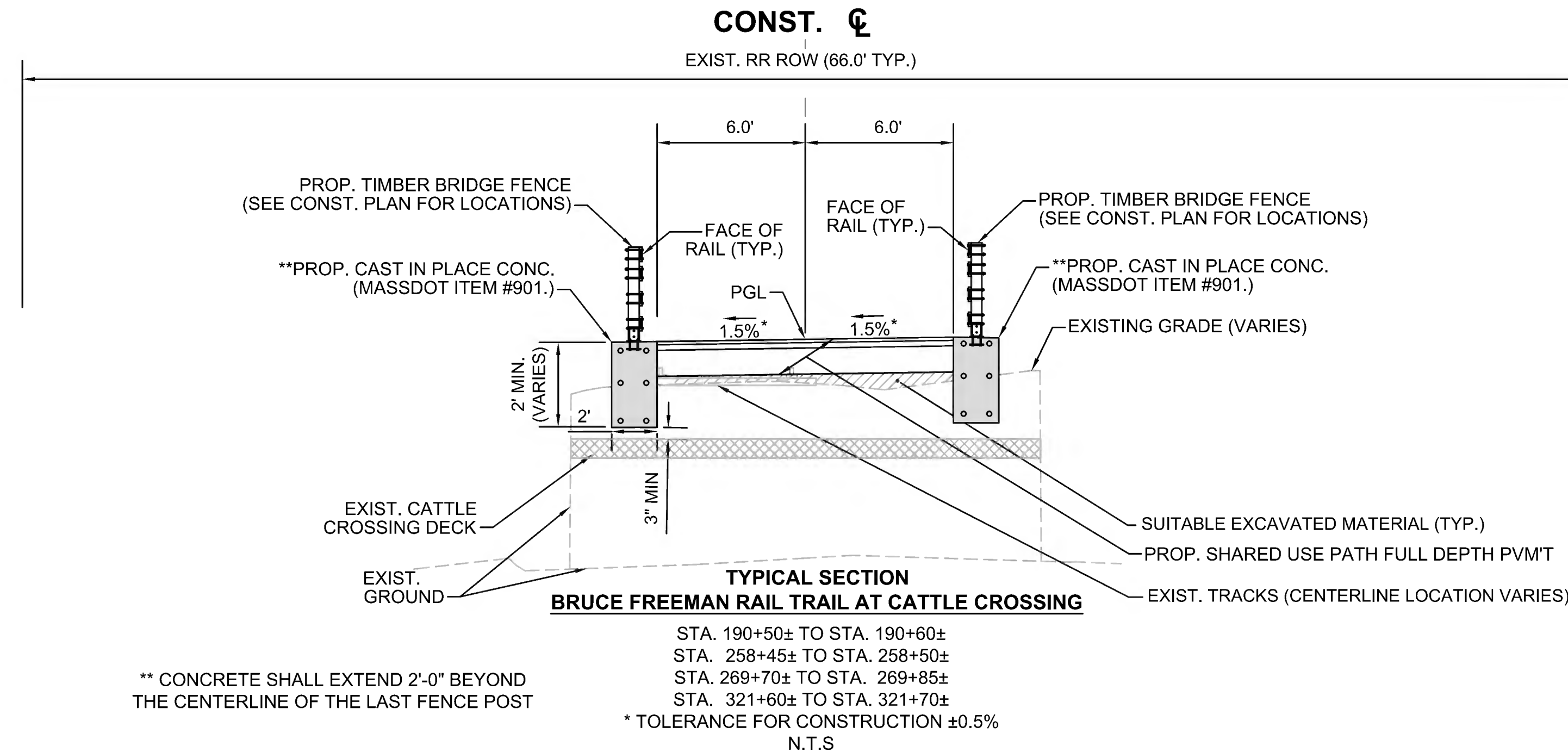
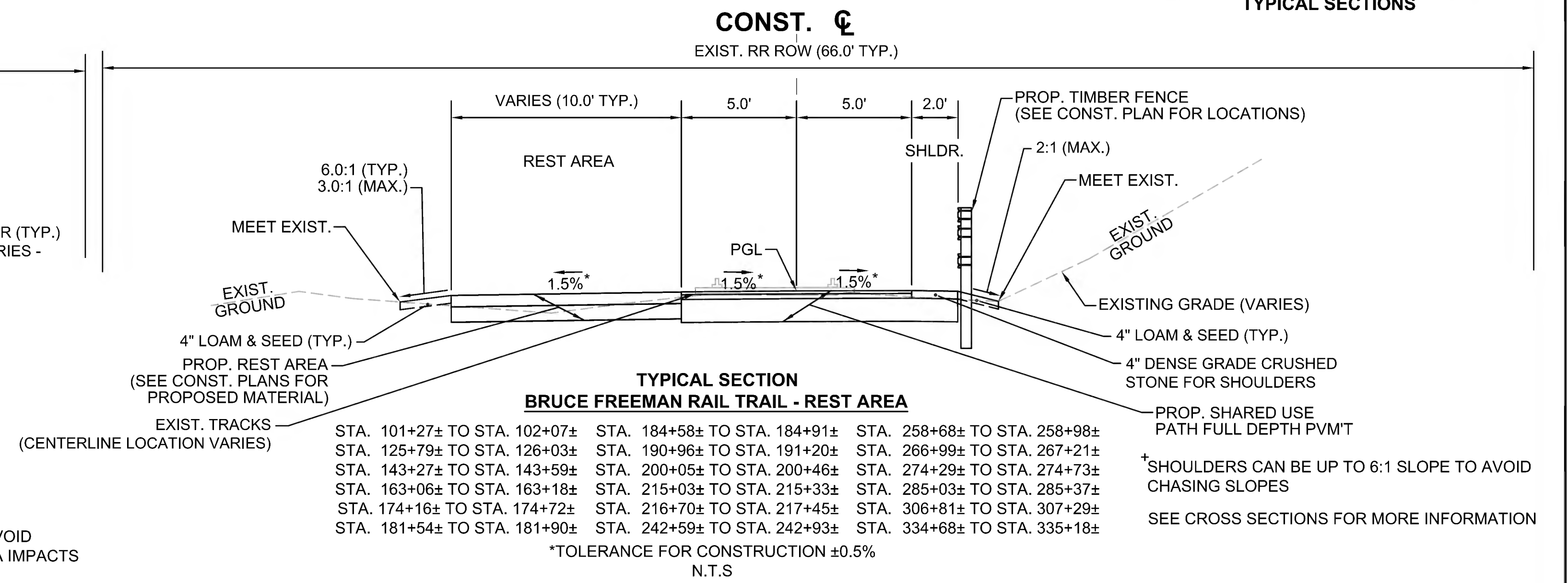
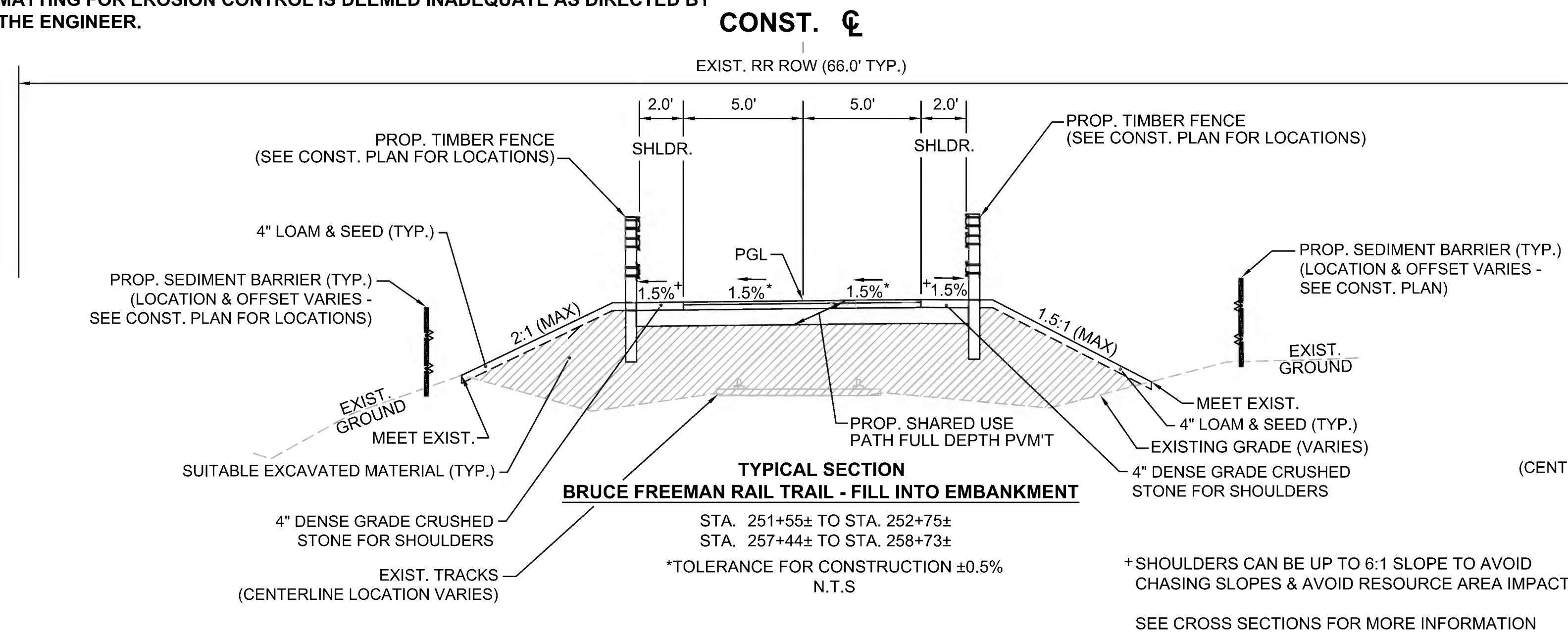

SEE SHEET 10 FOR PAVEMENT NOTE

SUBURBY BRUCE FREEMAN RAIL TRAIL			
STATE	FED. AID PROJ. NO.	SHEET NO.	TOTAL SHEETS
MA	XXX-XXX(XXX)X	12	319
PROJECT FILE NO.		608164	

TYPICAL SECTIONS

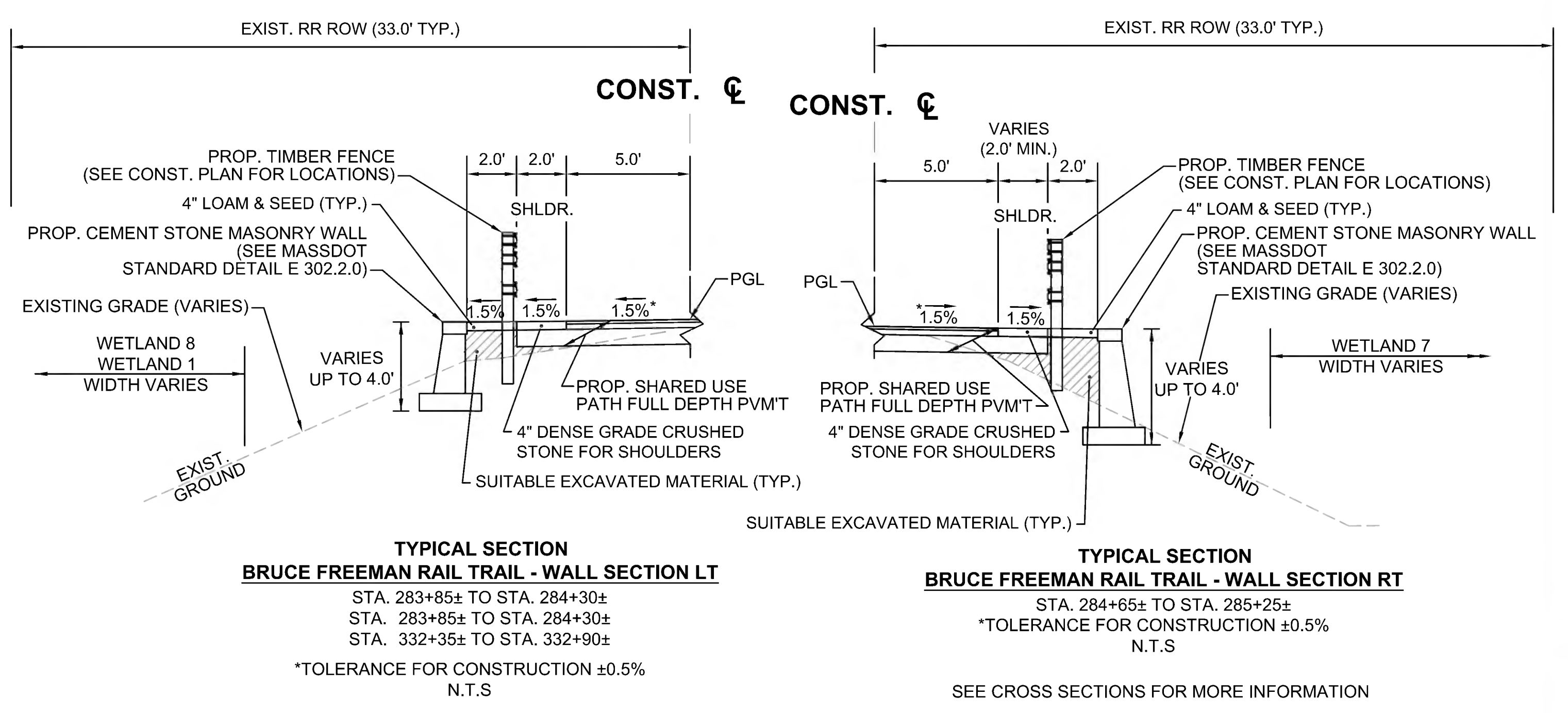
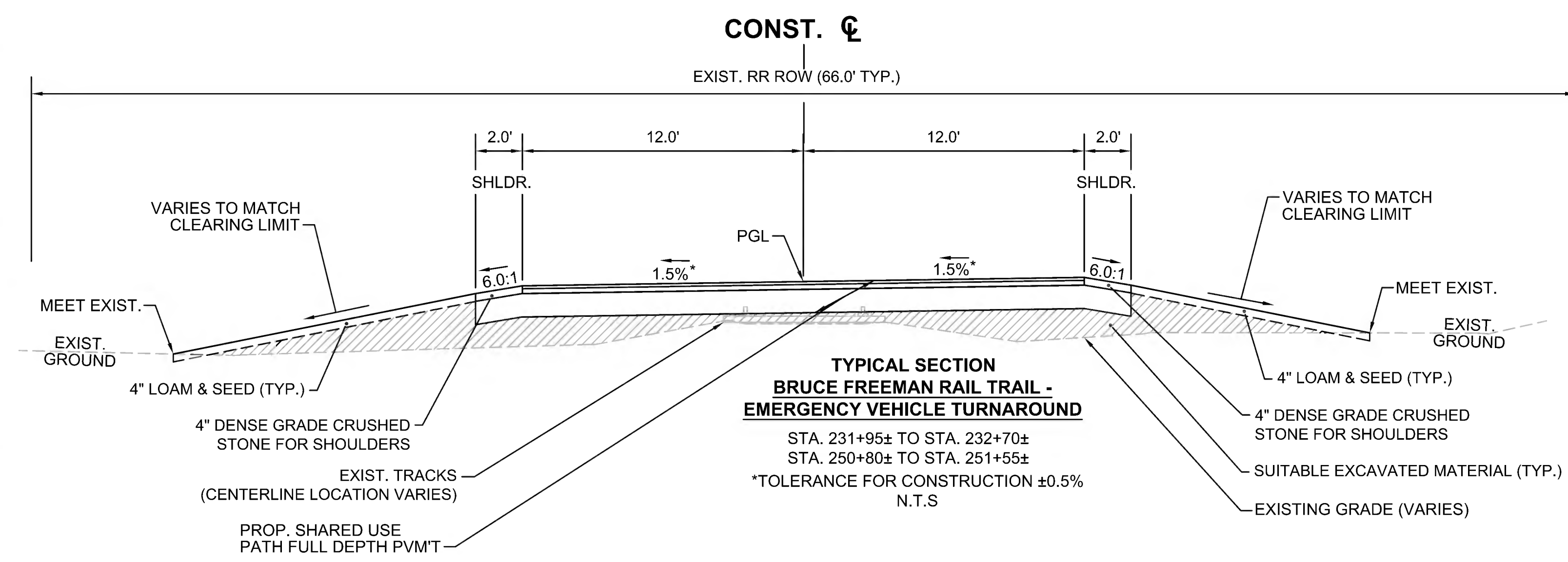
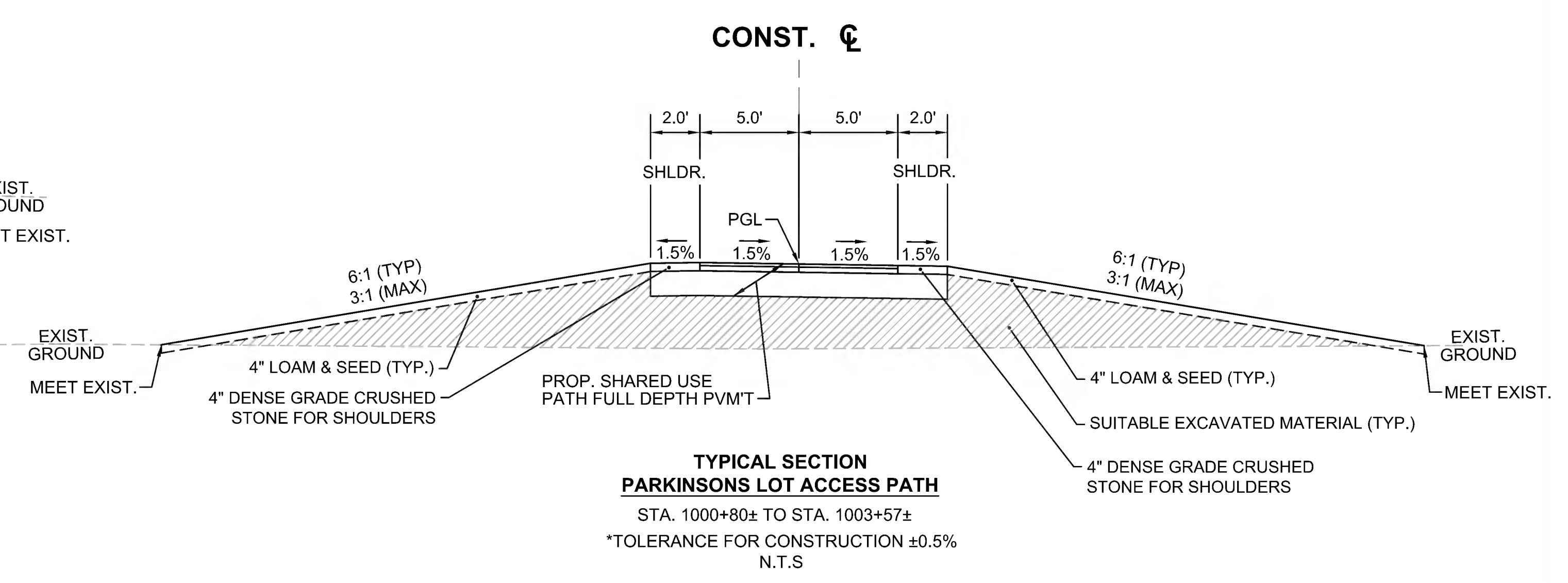
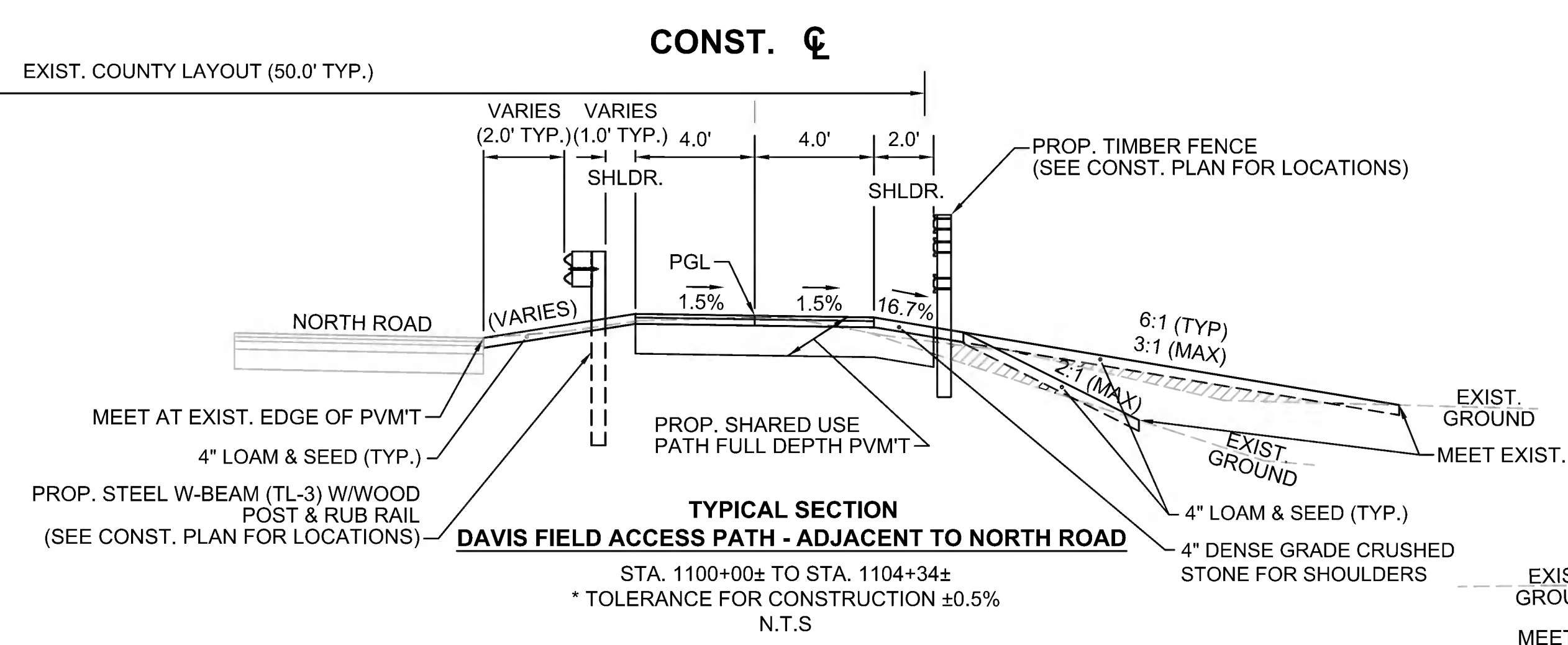
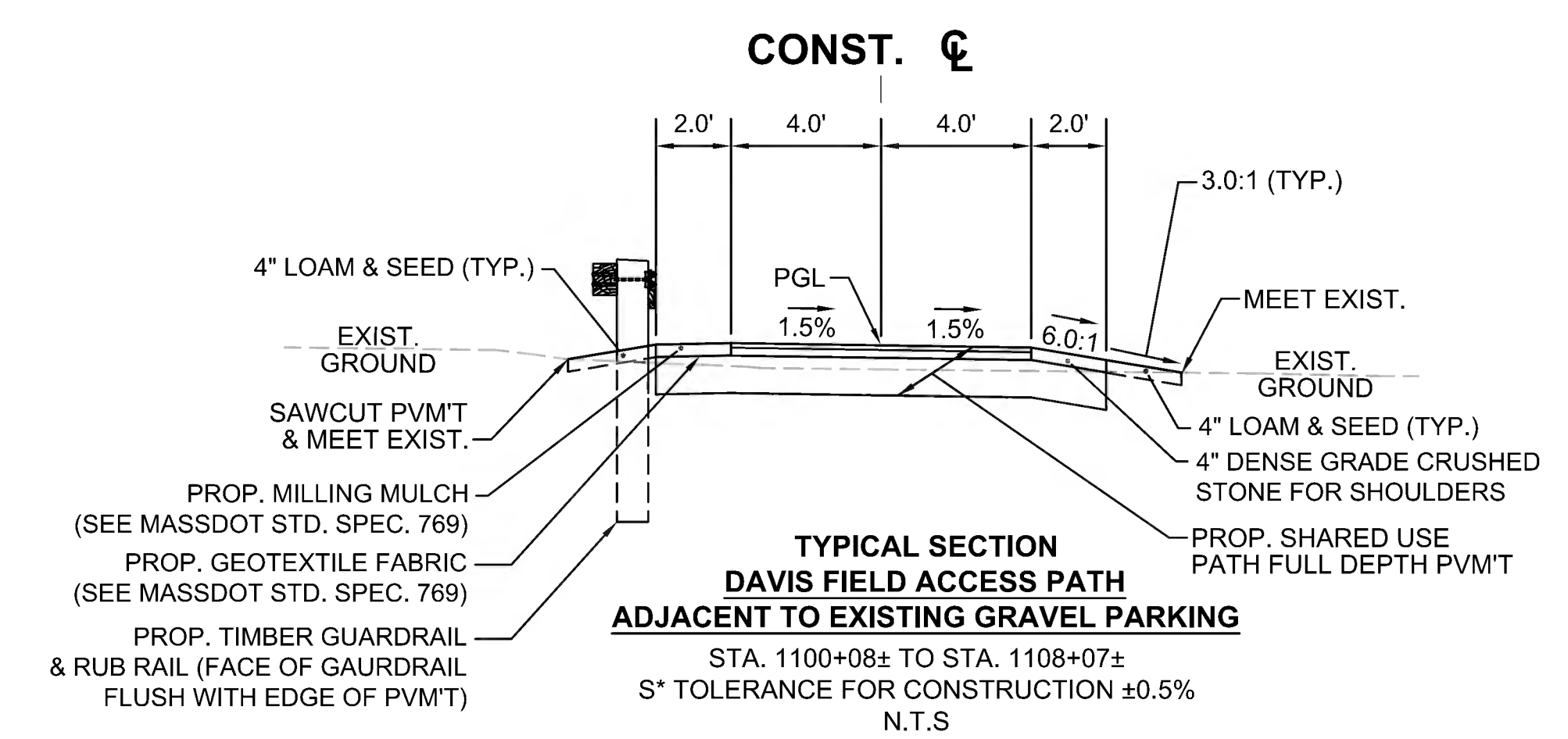
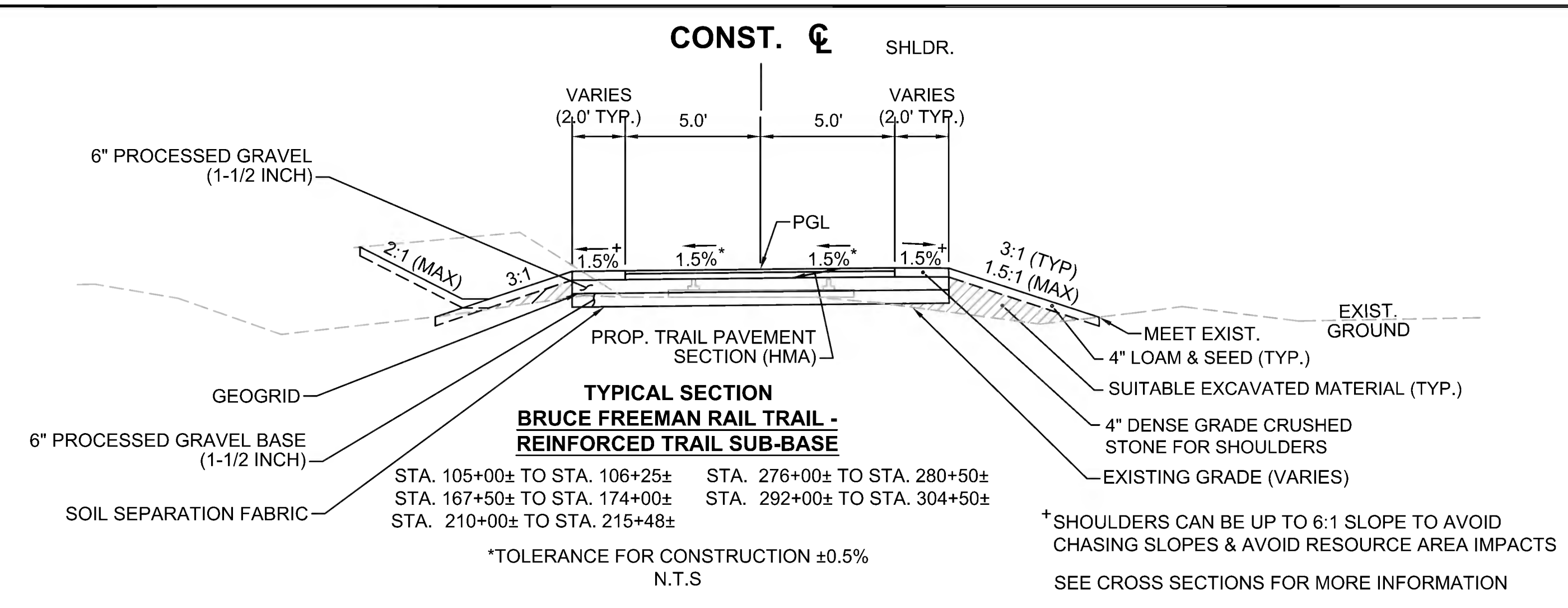

SEE CROSS SECTIONS FOR MORE INFORMATION
SEE GRADING PLANS FOR ELEVATIONS

SEE CROSS SECTIONS FOR MORE INFORMATION
SEE GRADING PLANS FOR ELEVATIONS

SEE SHEET 10 FOR PAVEMENT NOTES

SUBBURY BRUCE FREEMAN RAIL TRAIL			
STATE	FED. AID PROJ. NO.	SHEET NO.	TOTAL SHEETS
MA	XXX-XXXX(XXX)X	13	319
PROJECT FILE NO.		608164	

TYPICAL SECTIONS

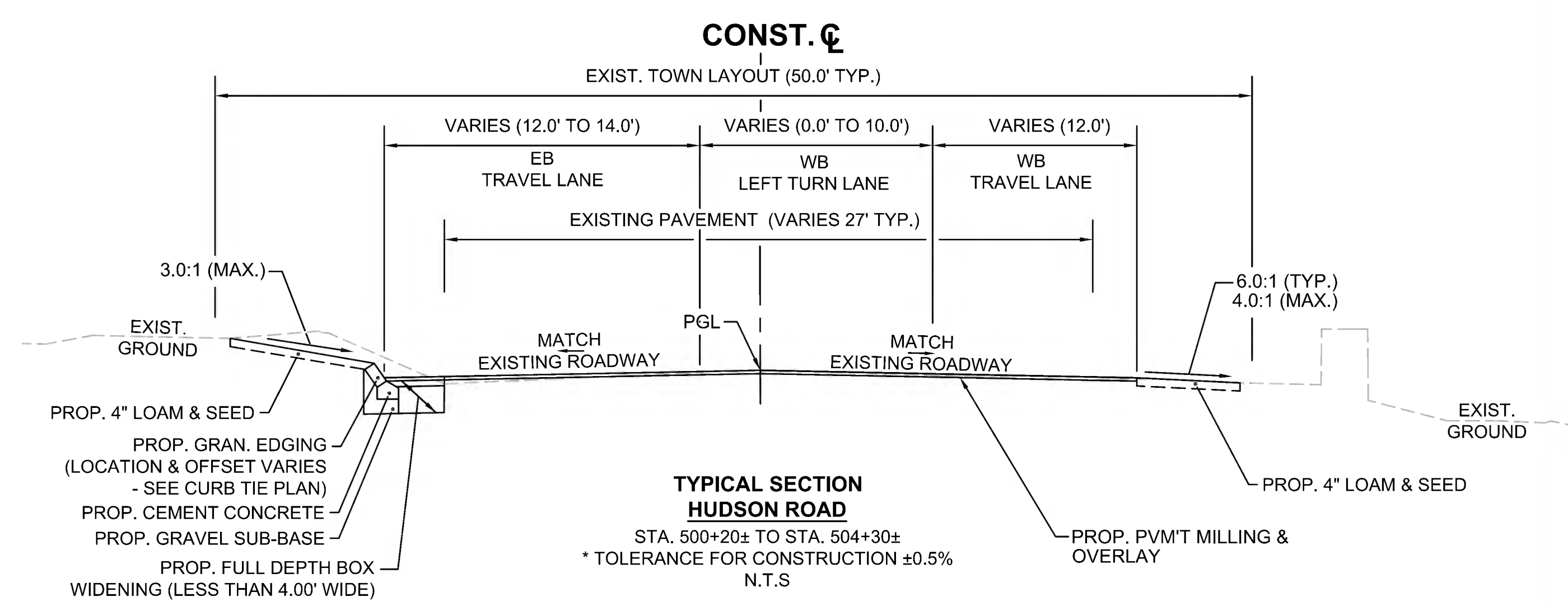
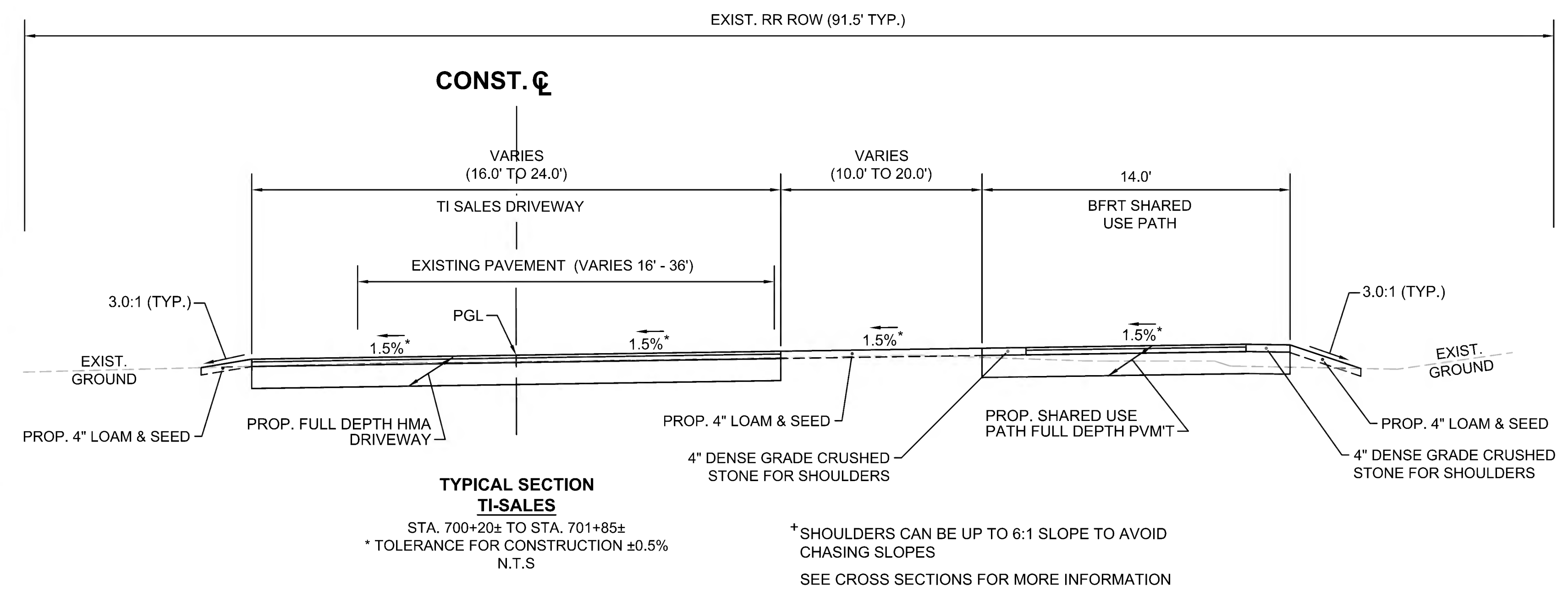
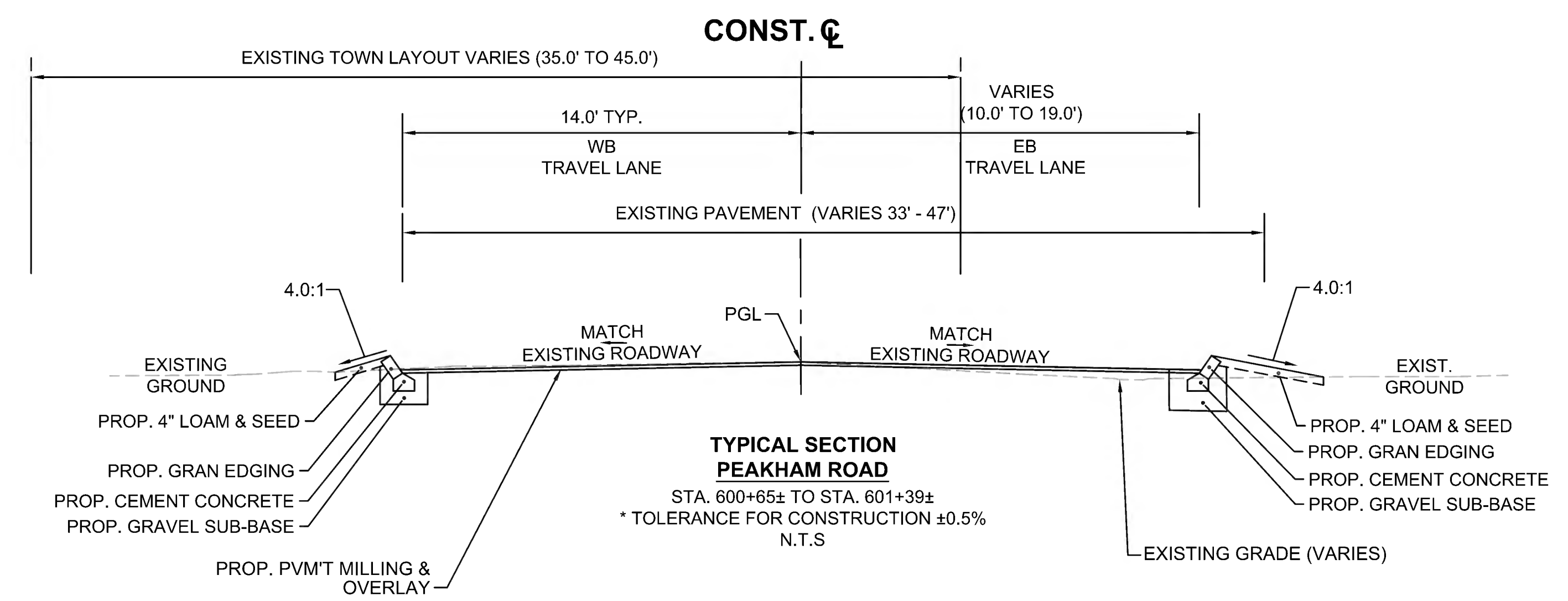
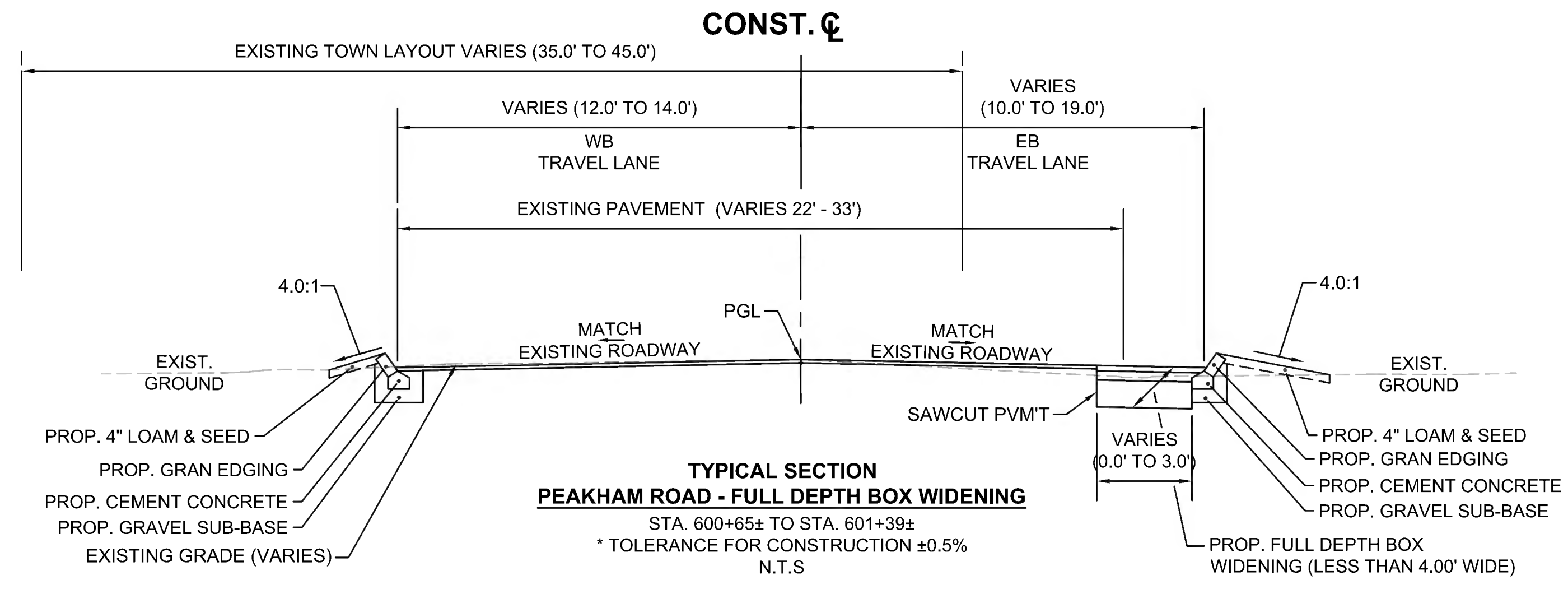

SEE SHEET 10 FOR PAVEMENT NOTES

**SUBURY
BRUCE FREEMAN RAIL TRAIL**

STATE	FED. AID PROJ. NO.	SHEET NO.	TOTAL SHEETS
MA	XXX-XXXX(XXX)X	14	319
PROJECT FILE NO.		608164	

TYPICAL SECTIONS

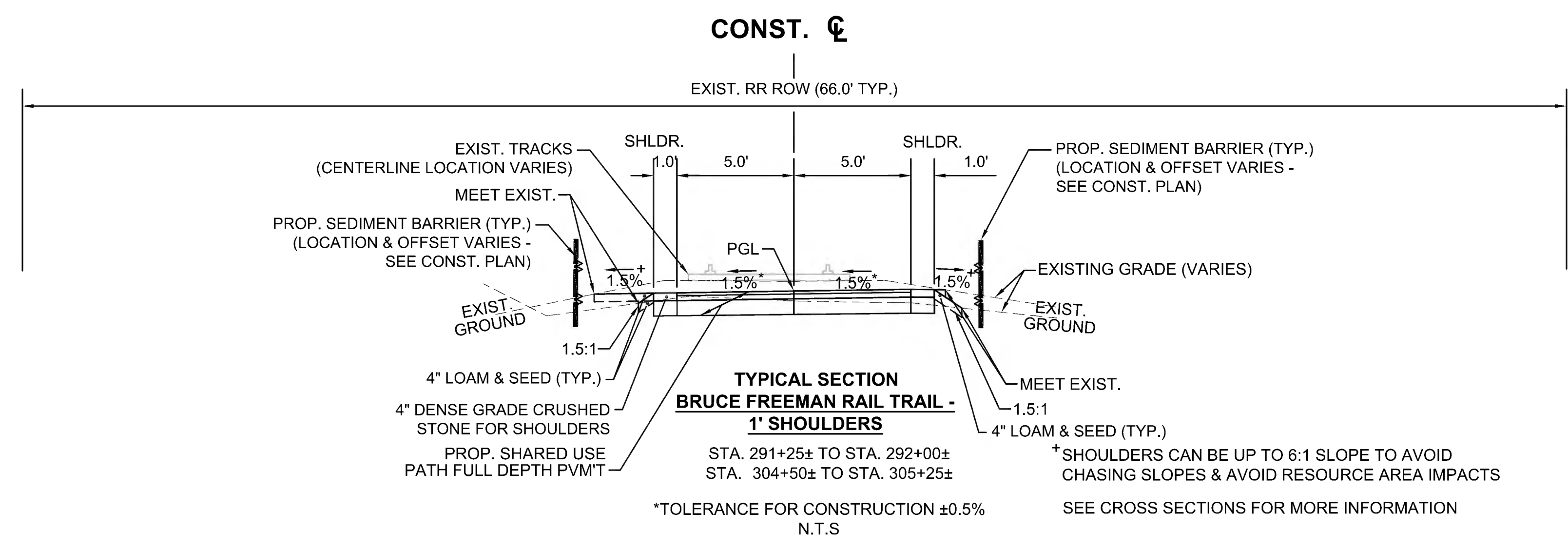

- NOTES:
- MATting FOR EROSION CONTROL SHALL BE INSTALLED ON SIDE SLOPES THAT ARE 2:1
 - GEOTEXTILE FABRIC FOR PERMANENT EROSION CONTROL SHALL BE USED AS NEEDED ON ANY CUT OR FILL SLOPES STEEPER THAN 2:1 WHERE POOR SOIL CONDITIONS EXIST AND MATting FOR EROSION CONTROL IS DEEMED INADEQUATE FOR GRASS ESTABLISHMENT AS DIRECTED BY THE ENGINEER.

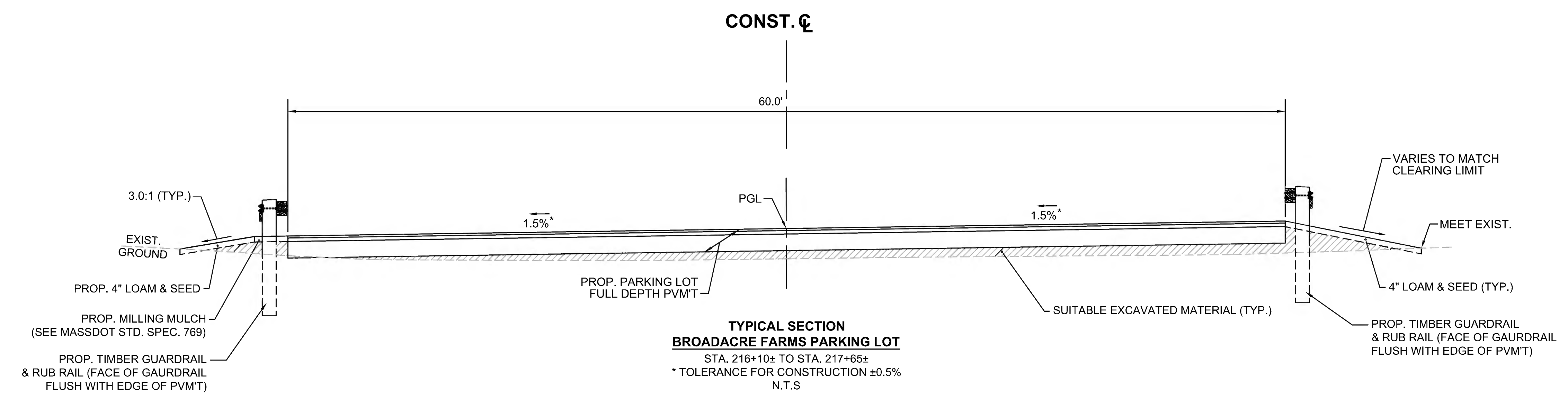
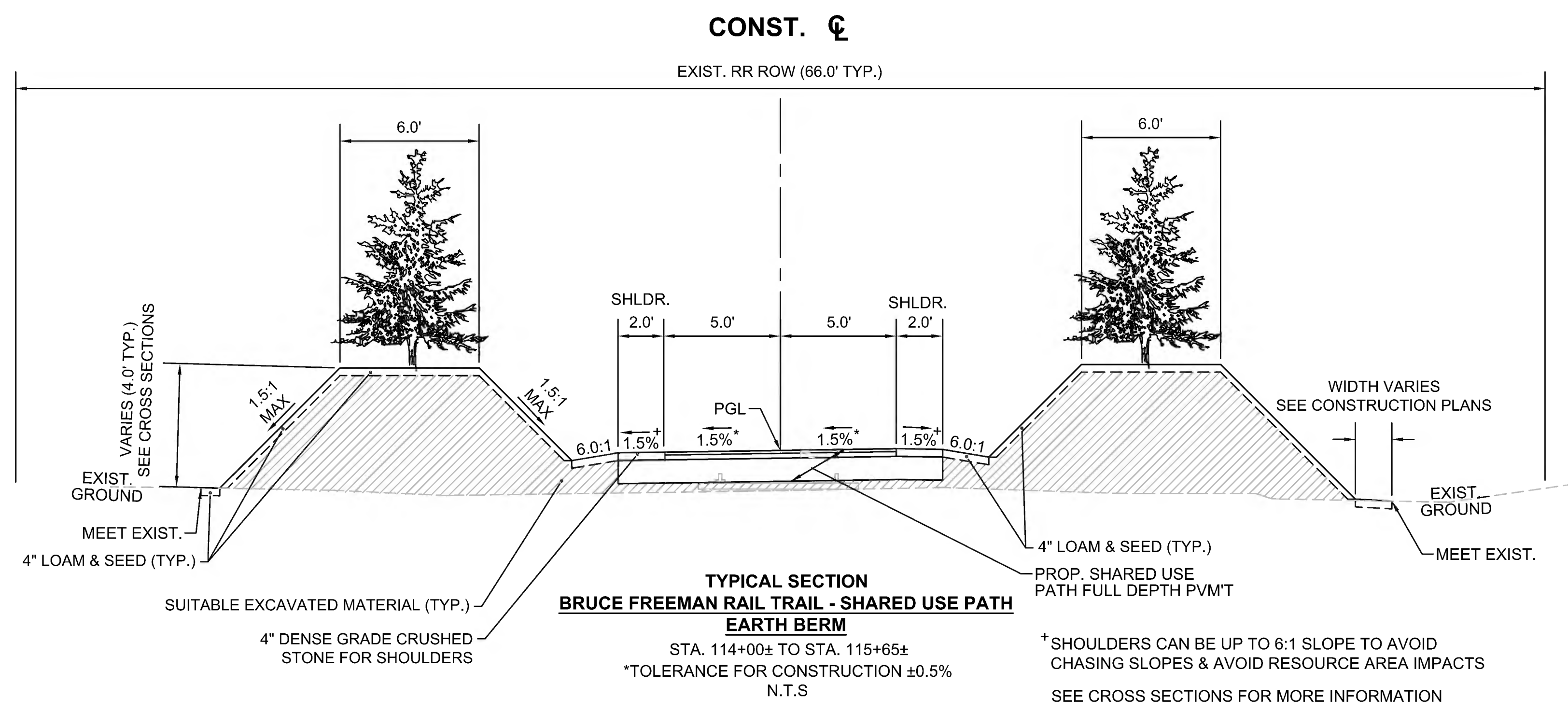
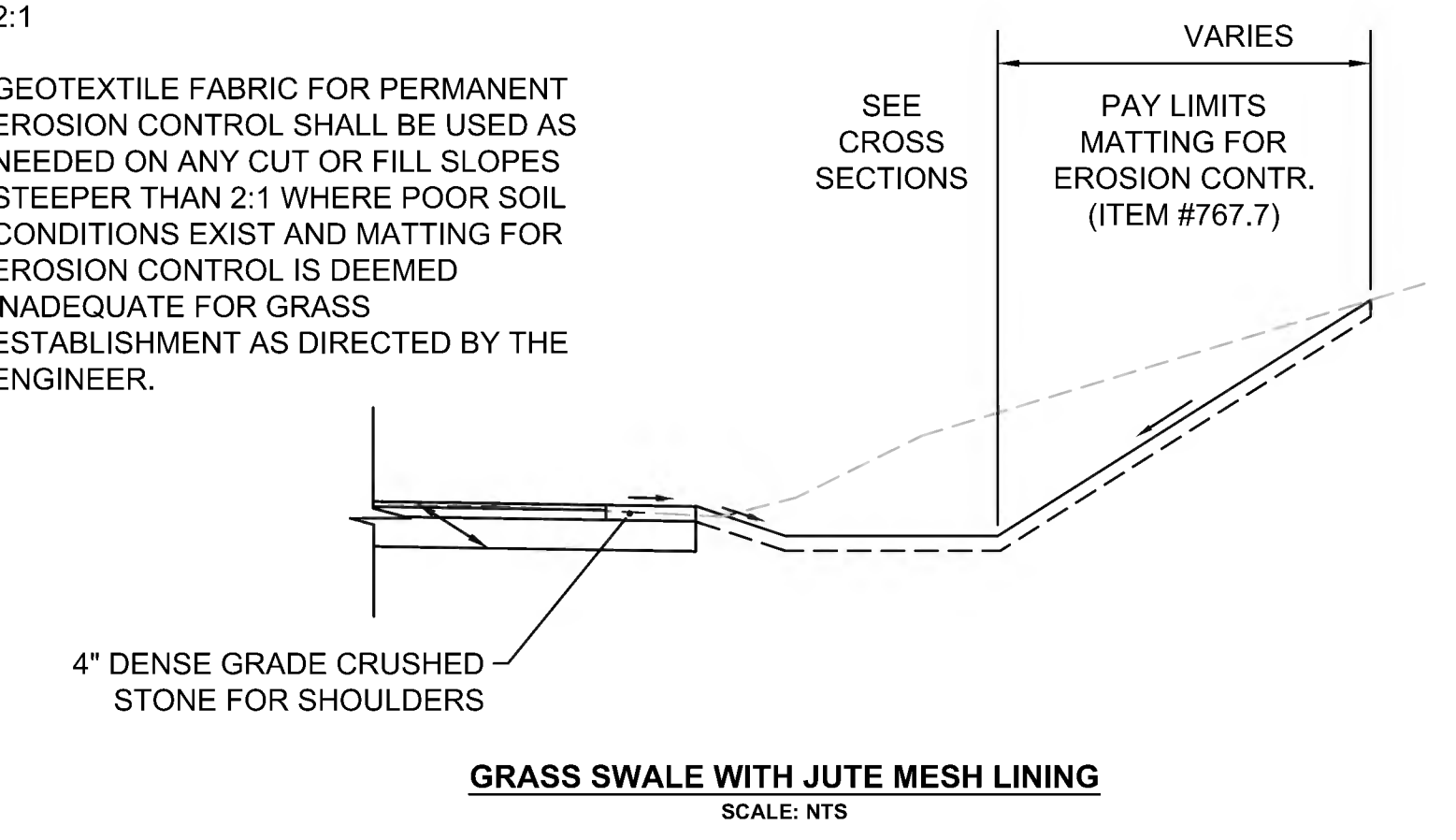

SEE SHEET 10 FOR PAVEMENT NOTES

SUDBURY BRUCE FREEMAN RAIL TRAIL			
STATE	FED. AID PROJ. NO.	SHEET NO.	TOTAL SHEETS
MA	XXX-XXXX(XXX)X	1	319
PROJECT FILE NO.		608164	

ENVIRONMENTAL IMPACT PLANS

LINETYPE	DESCRIPTION
(Symbol)	LIMIT OF BORDERING VEGETATED WETLAND (BVW)
(Symbol)	EDGE OF BORDERING LAND SUBJECT TO FLOODING
(Symbol)	LIMIT OF BANK
(Symbol)	LIMIT OF FEMA FLOODWAY
(Symbol)	ZONE A FLOOD LIMIT (NO BFE)
(Symbol)	APPROX. LIMIT OF GRADING
(Symbol)	100' WPA BUFFER ZONE
(Symbol)	100' WPA BUFFER ZONE/100' SUDBURY AURA
(Symbol)	100' WPA BUFFER ZONE/100' SUDBURY RESOURCE AREA
(Symbol)	100' WPA VERNAL POOL BUFFER ZONE
(Symbol)	100' WPA RESOURCE AREA
(Symbol)	200' WPA RA
(Symbol)	200' WPA RESOURCE AREA
(Symbol)	100' SUDBURY RESOURCE AREA
(Symbol)	200' SUDBURY RESOURCE AREA
(Symbol)	100' SUDBURY VERNAL POOL BUFFER ZONE
(Symbol)	100' or 200' SUDBURY AURA

LINETYPE	DESCRIPTION
(Symbol)	DRIVE SAMPLE BORING LOCATION
(Symbol)	TEST PIT LOCATION

HATCH	DESCRIPTION
(Symbol)	DISTURBANCE TO 100' WPA BUFFER ZONE (100' BZ)
(Symbol)	DISTURBANCE TO WPA 100' RIVERFRONT AREA (100' RA)
(Symbol)	DISTURBANCE TO WPA 200' RIVERFRONT AREA (200' RA)
(Symbol)	DISTURBANCE TO BLSF
(Symbol)	BORDERING VEGETATED WETLAND
(Symbol)	LIMIT OF BANK/LAND UNDER WATER

HATCH	DESCRIPTION
(Symbol)	TEMPORARY DISTURBANCE TO BVW / LUW / IVW
(Symbol)	PERMANENT DISTURBANCE TO BVW / LUW / IVW
(Symbol)	DISTURBANCE TO 100' WPA VERNAL POOL BZ

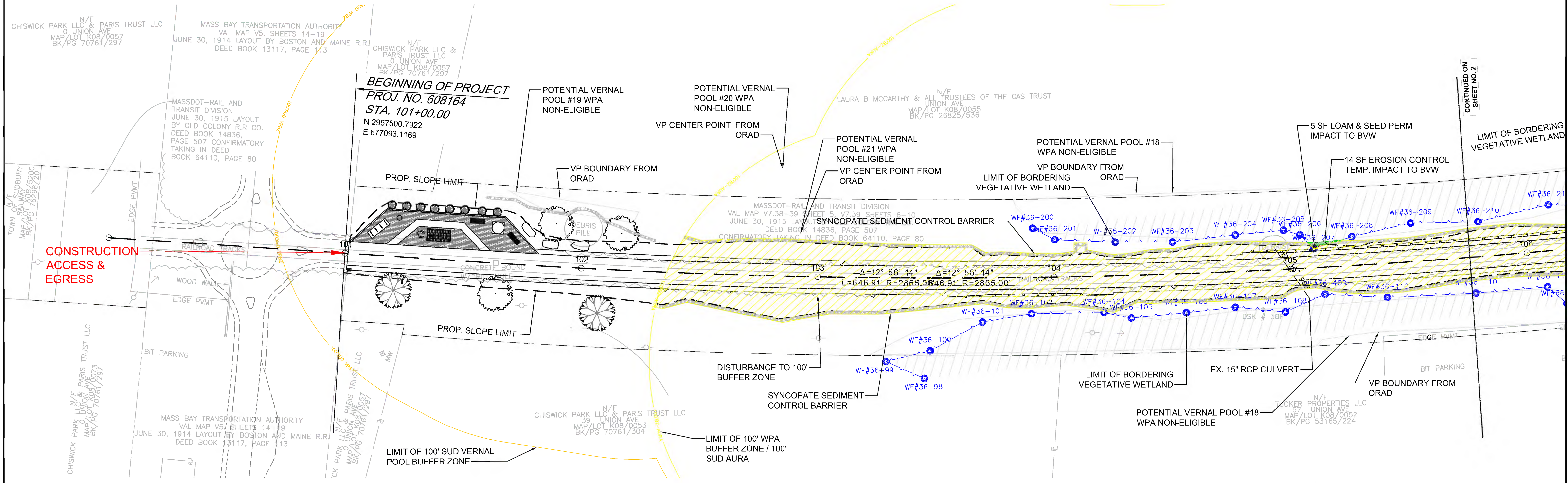

NOTES:

1. FOR THIS PROJECT, WPA RESOURCE AREAS ARE JURISDICTIONAL. TOWN BYLAW RESOURCE AREA BOUNDARIES ARE SHOWN FOR REFERENCE ONLY.
2. FOR PLANT LIST SEE CONSTRUCTION PLANS

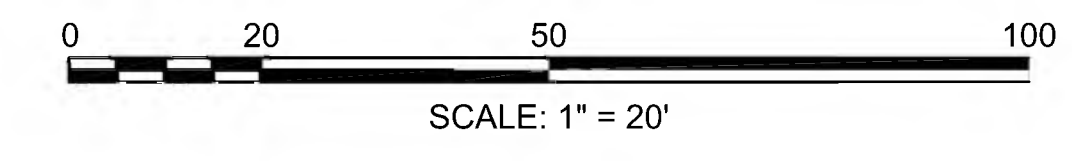

SUDBURY BRUCE FREEMAN RAIL TRAIL			
STATE	FED. AID PROJ. NO.	SHEET NO.	TOTAL SHEETS
MA	XXX-XXXX(XXX)X	2	319
PROJECT FILE NO.		608164	

ENVIRONMENTAL IMPACT PLANS

LINETYPE	DESCRIPTION	LINETYPE	DESCRIPTION	HATCH	DESCRIPTION	HATCH	DESCRIPTION
(Symbol)	LIMIT OF BORDERING VEGETATED WETLAND (BVW)	(Symbol)	DRIVE SAMPLE BORING LOCATION	(Symbol)	DISTURBANCE TO 100' WPA BUFFER ZONE (100' BZ)	(Symbol)	TEMPORARY DISTURBANCE TO BVW / LUW / IWV
(Symbol)	EDGE OF BORDERING LAND SUBJECT TO FLOODING	(Symbol)	TEST PIT LOCATION	(Symbol)	DISTURBANCE TO WPA 100' RIVERFRONT AREA (100' RA)	(Symbol)	PERMANENT DISTURBANCE TO BVW / LUW / IWV
(Symbol)	LIMIT OF BANK			(Symbol)	DISTURBANCE TO WPA 200' RIVERFRONT AREA (200' RA)	(Symbol)	DISTURBANCE TO 100' WPA VERNAL POOL BZ
(Symbol)	LIMIT OF FEMA FLOODWAY ZONE A FLOOD LIMIT (NO BFE)			(Symbol)	DISTURBANCE TO BLSF		
(Symbol)	APPROX. LIMIT OF GRADING			(Symbol)	BORDERING VEGETATED WETLAND		
(Symbol)	100' WPA BUFFER ZONE			(Symbol)	LIMIT OF BANK/LAND UNDER WATER		
(Symbol)	100' WPA BUFFER ZONE/100' SUDBURY AURA						
(Symbol)	100' WPA BUFFER ZONE/100' SUDBURY RESOURCE AREA						
(Symbol)	100' WPA VERNAL POOL BUFFER ZONE						
(Symbol)	100' WPA RESOURCE AREA						
(Symbol)	200' WPA RESOURCE AREA						
(Symbol)	100' SUDBURY RESOURCE AREA						
(Symbol)	200' SUDBURY RESOURCE AREA						
(Symbol)	100' SUDBURY VERNAL POOL BUFFER ZONE						
(Symbol)	100' SUDBURY AURA						

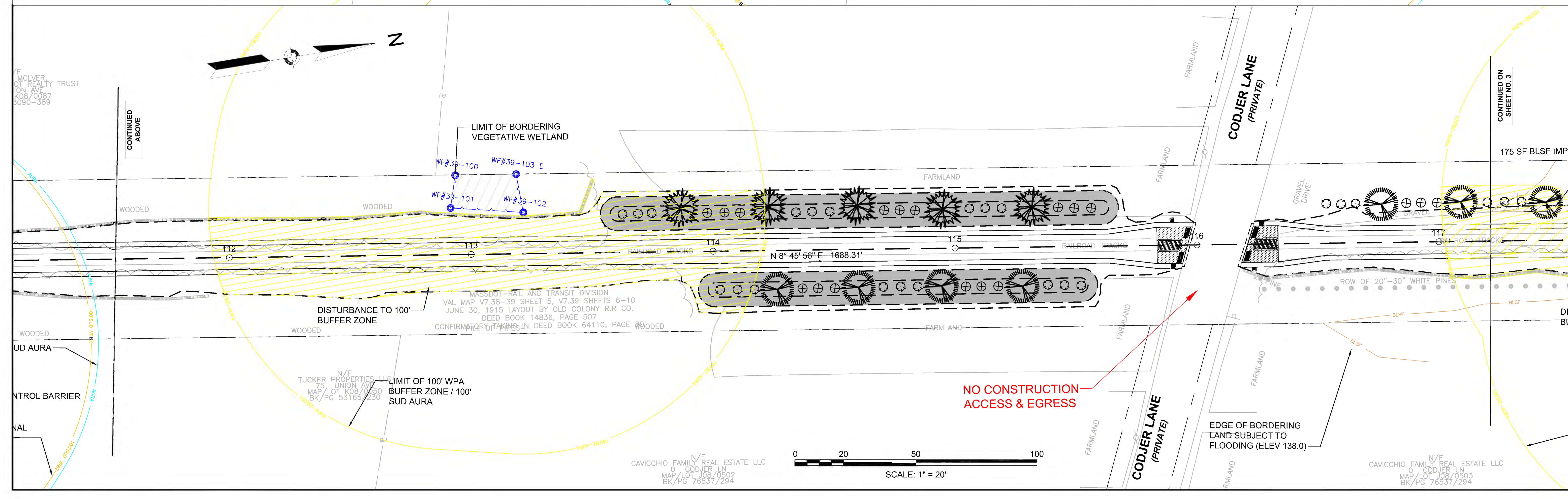
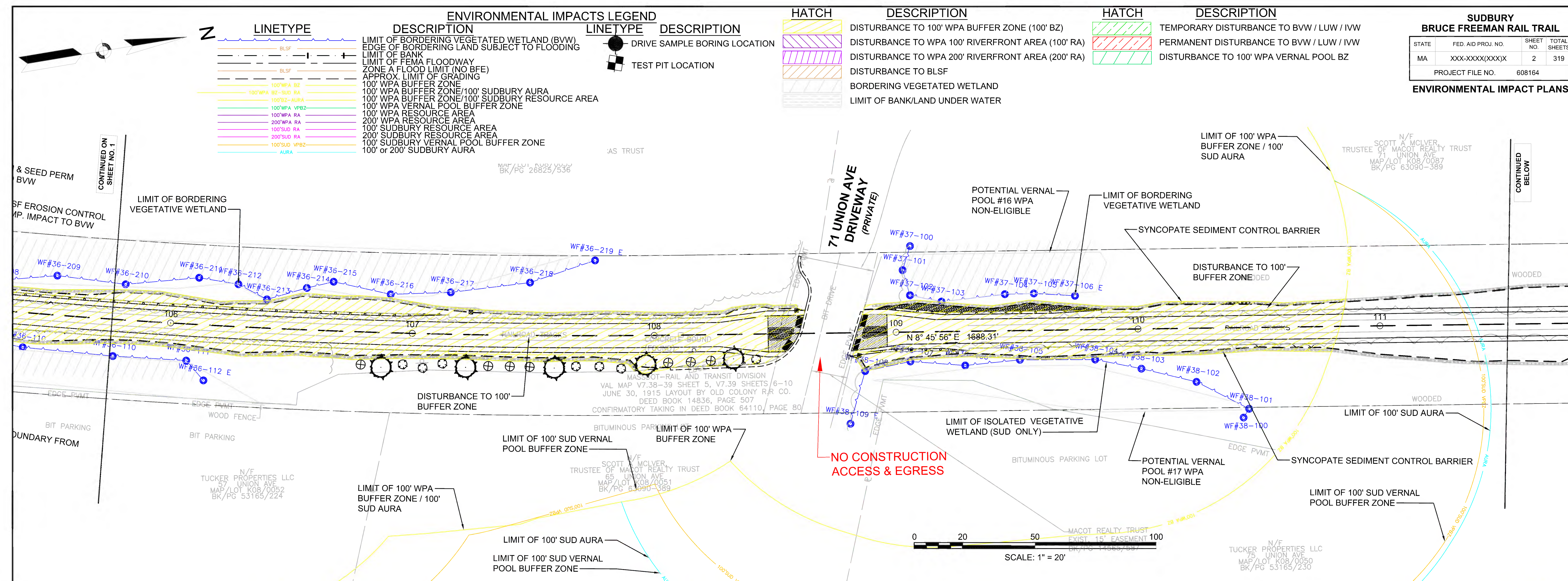

608164_NOI(GENERAL PLANS).DWG Plotted on 18-Feb-2022 4:52 PM

LINETYPE	DESCRIPTION	LINETYPE	DESCRIPTION
(Symbol)	LIMIT OF BORDERING VEGETATED WETLAND (BVW)	(Symbol)	DRIVE SAMPLE BORING LOCATION
(Symbol)	EDGE OF BORDERING LAND SUBJECT TO FLOODING	(Symbol)	TEST PIT LOCATION
(Symbol)	LIMIT OF BANK		
(Symbol)	LIMIT OF FEMA FLOODWAY ZONE A FLOOD LIMIT (NO BFE)		
(Symbol)	APPROX. LIMIT OF GRADING		
(Symbol)	100' WPA BUFFER ZONE		
(Symbol)	100' WPA BUFFER ZONE/100' SUDBURY AURA		
(Symbol)	100' WPA BUFFER ZONE/100' SUDBURY RESOURCE AREA		
(Symbol)	100' WPA VERNAL POOL BUFFER ZONE		
(Symbol)	100' WPA RESOURCE AREA		
(Symbol)	200' WPA RESOURCE AREA		
(Symbol)	100' SUDBURY RESOURCE AREA		
(Symbol)	200' SUDBURY RESOURCE AREA		
(Symbol)	100' SUDBURY VERNAL POOL BUFFER ZONE		
(Symbol)	100' or 200' SUDBURY AURA		

HATCH	DESCRIPTION
(Hatch)	DISTURBANCE TO 100' WPA BUFFER ZONE (100' BZ)
(Hatch)	DISTURBANCE TO WPA 100' RIVERFRONT AREA (100' RA)
(Hatch)	DISTURBANCE TO WPA 200' RIVERFRONT AREA (200' RA)
(Hatch)	DISTURBANCE TO BLSF
(Hatch)	BORDERING VEGETATED WETLAND
(Hatch)	LIMIT OF BANK/LAND UNDER WATER

HATCH	DESCRIPTION
(Hatch)	TEMPORARY DISTURBANCE TO BVW / LUW / IVW
(Hatch)	PERMANENT DISTURBANCE TO BVW / LUW / IVW
(Hatch)	DISTURBANCE TO 100' WPA VERNAL POOL BZ

SUDBURY BRUCE FREEMAN RAIL TRAIL			
STATE	FED. AID PROJ. NO.	SHEET NO.	TOTAL SHEETS
MA	XXX-XXXX(XXX)X	3	319
PROJECT FILE NO.		608164	
ENVIRONMENTAL IMPACT PLANS			

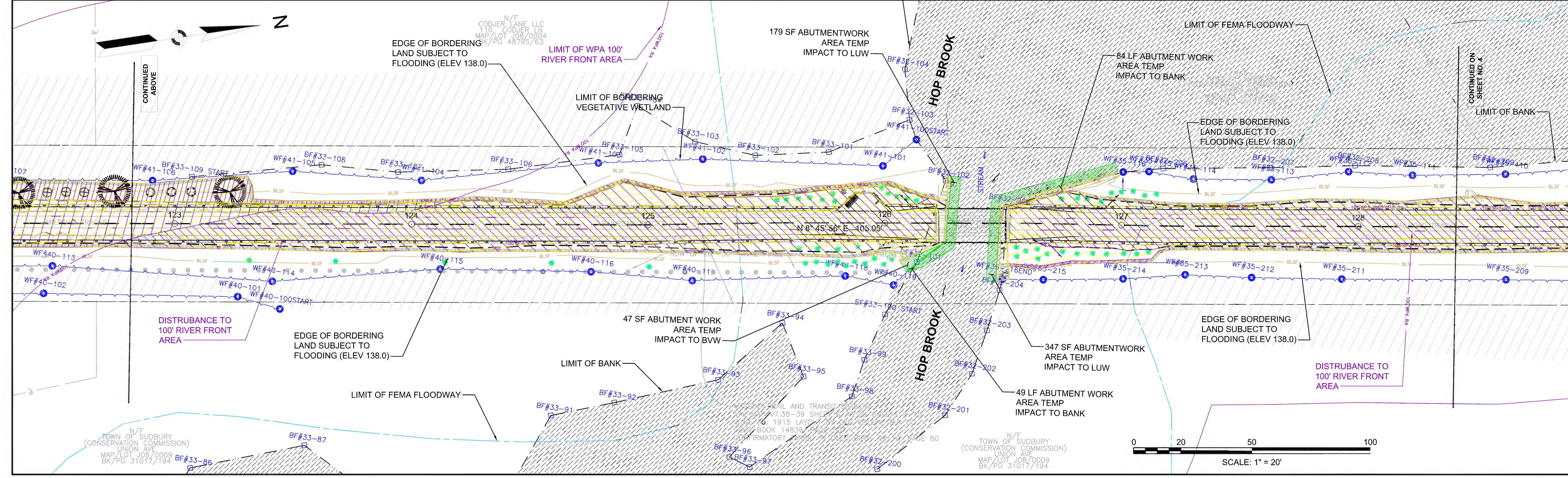
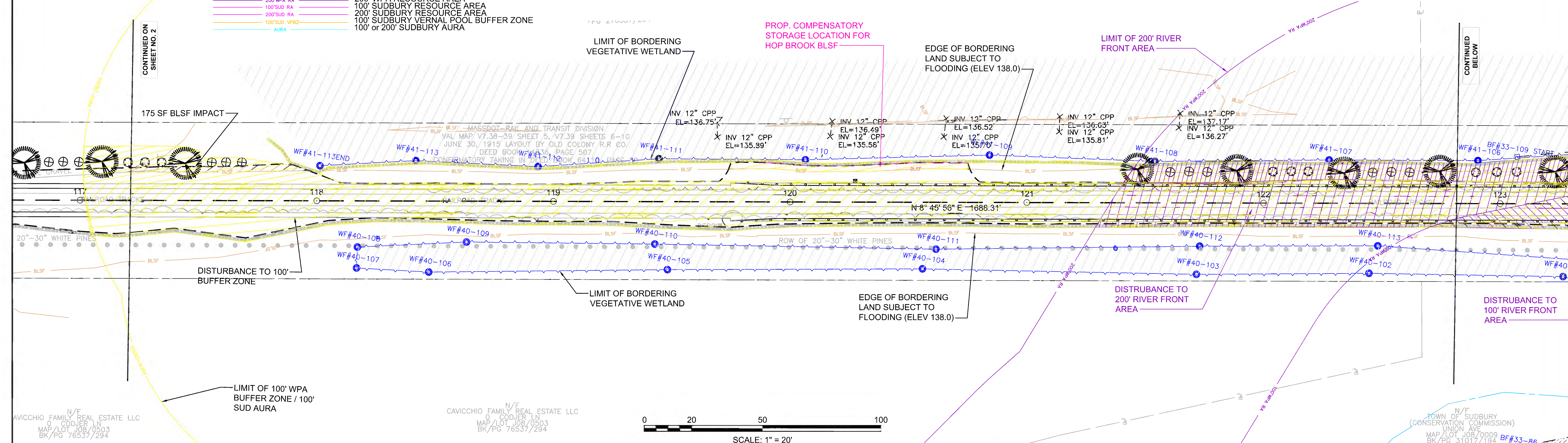

BRUCE FREEMAN RAIL TRAIL			
STATE	FED. AID PROJ. NO.	SHEET NO.	TOTAL SHEETS
MA	XXX-XXXX(XXX)X	4	319
PROJECT FILE NO.		608164	

ENVIRONMENTAL IMPACT PLANS

LINETYPE	DESCRIPTION	LINETYPE	DESCRIPTION
(Symbol)	LIMIT OF BORDERING VEGETATED WETLAND (BVW)	(Symbol)	DRIVE SAMPLE BORING LOCATION
(Symbol)	EDGE OF BORDERING LAND SUBJECT TO FLOODING	(Symbol)	TEST PIT LOCATION
(Symbol)	LIMIT OF BANK		
(Symbol)	LIMIT OF FEMA FLOODWAY ZONE A FLOOD LIMIT (NO BFE)		
(Symbol)	APPROX. LIMIT OF GRADING		
(Symbol)	100' WPA BUFFER ZONE		
(Symbol)	100' WPA BUFFER ZONE/100' SUDBURY AURA		
(Symbol)	100' WPA BUFFER ZONE/100' SUDBURY RESOURCE AREA		
(Symbol)	100' WPA VERNAL POOL BUFFER ZONE		
(Symbol)	100' WPA RESOURCE AREA		
(Symbol)	200' WPA RESOURCE AREA		
(Symbol)	100' SUDBURY RESOURCE AREA		
(Symbol)	200' SUDBURY RESOURCE AREA		
(Symbol)	100' SUDBURY VERNAL POOL BUFFER ZONE		
(Symbol)	100' or 200' SUDBURY AURA		

HATCH	DESCRIPTION	HATCH	DESCRIPTION
(Symbol)	DISTURBANCE TO 100' WPA BUFFER ZONE (100' BZ)	(Symbol)	TEMPORARY DISTURBANCE TO BVW / LUW / IVW
(Symbol)	DISTURBANCE TO WPA 100' RIVERFRONT AREA (100' RA)	(Symbol)	PERMANENT DISTURBANCE TO BVW / LUW / IVW
(Symbol)	DISTURBANCE TO WPA 200' RIVERFRONT AREA (200' RA)	(Symbol)	DISTURBANCE TO 100' WPA VERNAL POOL BZ
(Symbol)	DISTURBANCE TO BLSF		
(Symbol)	BORDERING VEGETATED WETLAND		
(Symbol)	LIMIT OF BANK/LAND UNDER WATER		

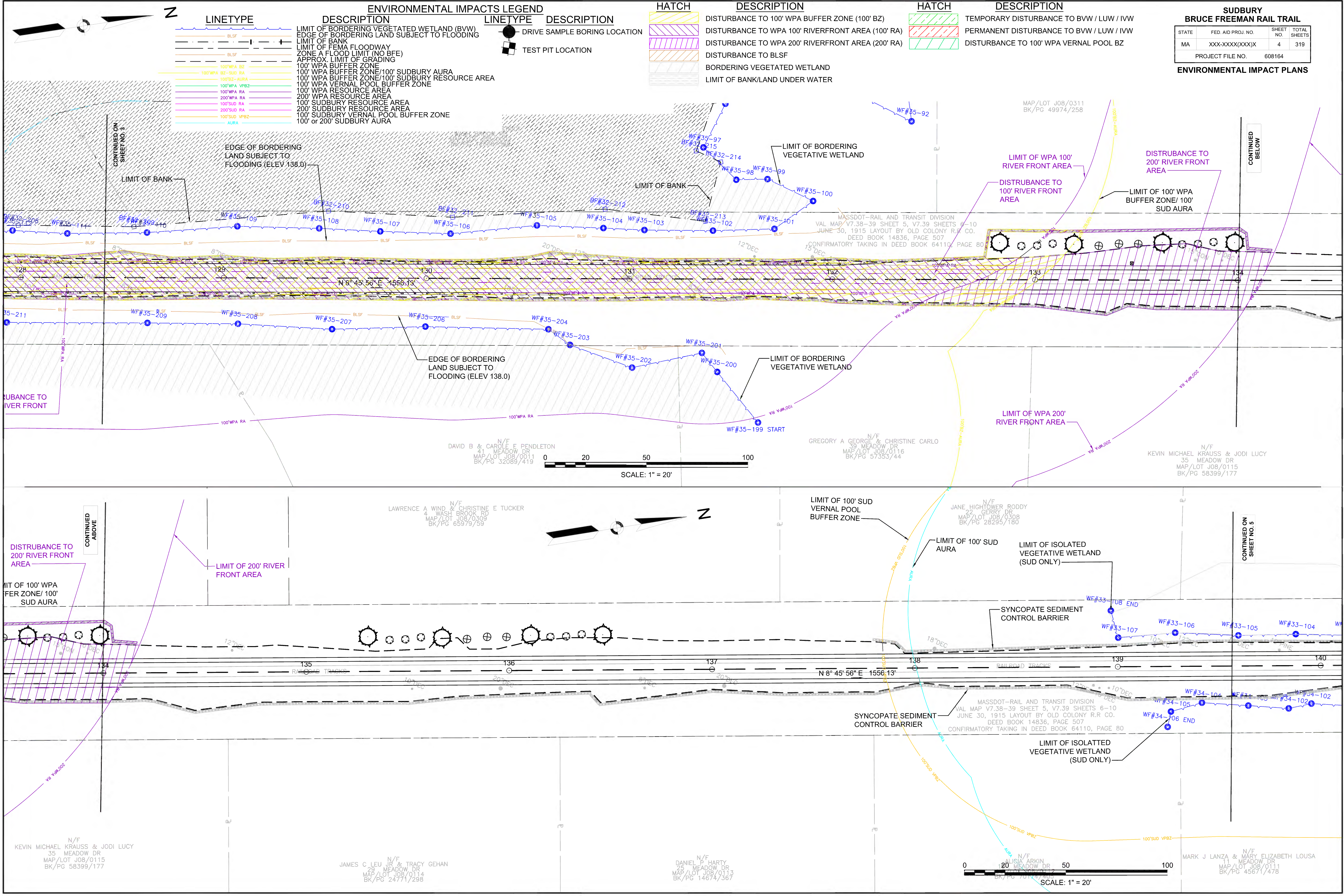

CONTINUED BELOW

CONTINUED ON SHEET NO. 5

CONTINUED ON SHEET NO. 3

CONTINUED ABOVE

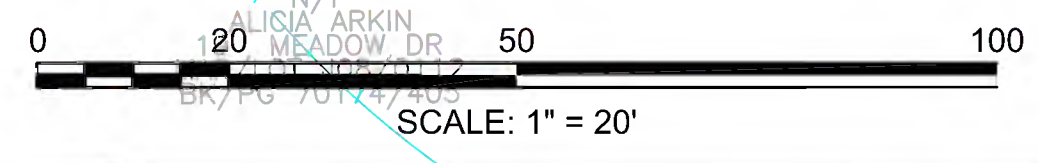
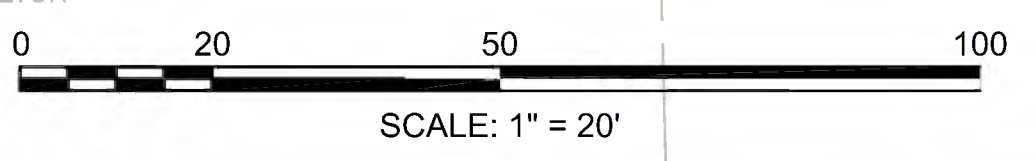

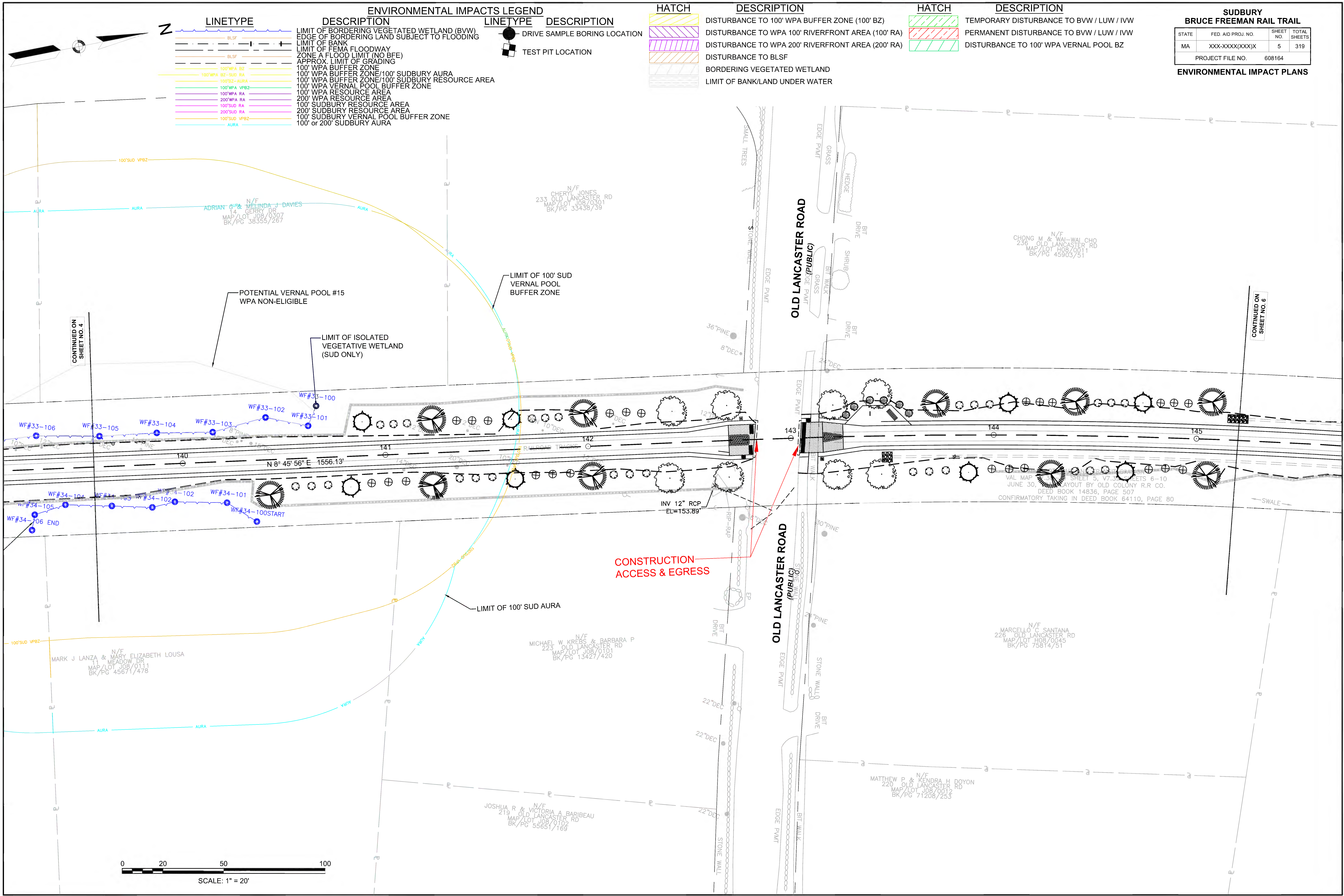

ENVIRONMENTAL IMPACTS LEGEND	
LINETYPE	DESCRIPTION
	LIMIT OF BORDERING VEGETATED WETLAND (BVW)
	EDGE OF BORDERING LAND SUBJECT TO FLOODING
	LIMIT OF BANK
	LIMIT OF FEMA FLOODWAY
	ZONE A FLOOD LIMIT (NO BFE)
	APPROX. LIMIT OF GRADING
	100' WPA BUFFER ZONE
	100' WPA BUFFER ZONE/100' SUDBURY AURA
	100' WPA BUFFER ZONE/100' SUDBURY RESOURCE AREA
	100' WPA VERNAL POOL BUFFER ZONE
	100' WPA RESOURCE AREA
	200' WPA RESOURCE AREA
	100' SUDBURY RESOURCE AREA
	200' SUDBURY RESOURCE AREA
	100' SUDBURY VERNAL POOL BUFFER ZONE
	100' or 200' SUDBURY AURA

HATCH	DESCRIPTION
	DISTURBANCE TO 100' WPA BUFFER ZONE (100' BZ)
	DISTURBANCE TO WPA 100' RIVERFRONT AREA (100' RA)
	DISTURBANCE TO WPA 200' RIVERFRONT AREA (200' RA)
	DISTURBANCE TO BLSF
	BORDERING VEGETATED WETLAND
	LIMIT OF BANK/LAND UNDER WATER

HATCH	DESCRIPTION
	TEMPORARY DISTURBANCE TO BVW / LUW / IVW
	PERMANENT DISTURBANCE TO BVW / LUW / IVW
	DISTURBANCE TO 100' WPA VERNAL POOL BZ

SUDBURY BRUCE FREEMAN RAIL TRAIL			
STATE	FED. AID PROJ. NO.	SHEET NO.	TOTAL SHEETS
MA	XXX-XXXX(XXX)X	5	319
PROJECT FILE NO.		608164	

ENVIRONMENTAL IMPACT PLANS

CONTINUED ON SHEET NO. 4

CONTINUED ON SHEET NO. 6

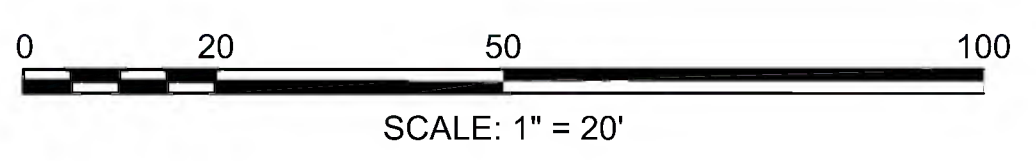

CONSTRUCTION ACCESS & EGRESS

VAL MAP SHEET 5, V7, SHEETS 6-10
JUNE 30, 1988 LAYOUT BY OLD COLONY R.R. CO.
DEED BOOK 14836, PAGE 507
CONFIRMATORY TAKING IN DEED BOOK 64110, PAGE 80

N/F MARCELLO C. SANTANA
226 OLD LANCASTER RD
MAP/LOT 108/0045
BK/PG 75814/51

N/F MATTHEW P. & KENDRA H. DOYON
220 OLD LANCASTER RD
MAP/LOT 108/0012
BK/PG 71208/253

N/F JOSHUA R. & VICTORIA A. BARIBEAU
219 OLD LANCASTER RD
MAP/LOT 108/0102
BK/PG 55651/169

N/F MICHAEL W. KREBS & BARBARA P.
223 OLD LANCASTER RD
MAP/LOT 108/0101
BK/PG 13427/420

N/F CHONG M. & WAL-WAL CHO
236 OLD LANCASTER RD
MAP/LOT 108/0011
BK/PG 45903/51

N/F CHERYL JONES
233 OLD LANCASTER RD
MAP/LOT 108/0301
BK/PG 33436/39

N/F ADRIAN G. & MELINDA J. DAVIES
14 GERRY DR
MAP/LOT 105/0307
BK/PG 38355/267

N/F MARK J. LANZA & MARY ELIZABETH LOUSA
11 MEADOW DR
MAP/LOT 108/0111
BK/PG 45671/478

BRUCE FREEMAN RAIL TRAIL			
STATE	FED. AID PROJ. NO.	SHEET NO.	TOTAL SHEETS
MA	XXX-XXXX(XXX)X	6	319
PROJECT FILE NO.		608164	

ENVIRONMENTAL IMPACT PLANS

ENVIRONMENTAL IMPACTS LEGEND		HATCH		HATCH	
LINETYPE	DESCRIPTION		DESCRIPTION		DESCRIPTION
	LIMIT OF BORDERING VEGETATED WETLAND (BVW)		DISTURBANCE TO 100' WPA BUFFER ZONE (100' BZ)		TEMPORARY DISTURBANCE TO BVW / LUW / IVW
	EDGE OF BANKING LAND SUBJECT TO FLOODING		DISTURBANCE TO WPA 100' RIVERFRONT AREA (100' RA)		PERMANENT DISTURBANCE TO BVW / LUW / IVW
	LIMIT OF BANK		DISTURBANCE TO WPA 200' RIVERFRONT AREA (200' RA)		DISTURBANCE TO 100' WPA VERNAL POOL BZ
	LIMIT OF FEMA FLOODWAY		DISTURBANCE TO BLSF		
	ZONE A FLOOD LIMIT (NO BFE)		BORDERING VEGETATED WETLAND		
	APPROX. LIMIT OF GRADING		LIMIT OF BANK/LAND UNDER WATER		
	100' WPA BUFFER ZONE				
	100' WPA BUFFER ZONE/100' SUDBURY AURA				
	100' WPA BUFFER ZONE/100' SUDBURY RESOURCE AREA				
	100' WPA VERNAL POOL BUFFER ZONE				
	100' WPA RESOURCE AREA				
	200' WPA RESOURCE AREA				
	100' SUDBURY RESOURCE AREA				
	200' SUDBURY RESOURCE AREA				
	100' SUDBURY VERNAL POOL BUFFER ZONE				
	100' or 200' SUDBURY AURA				

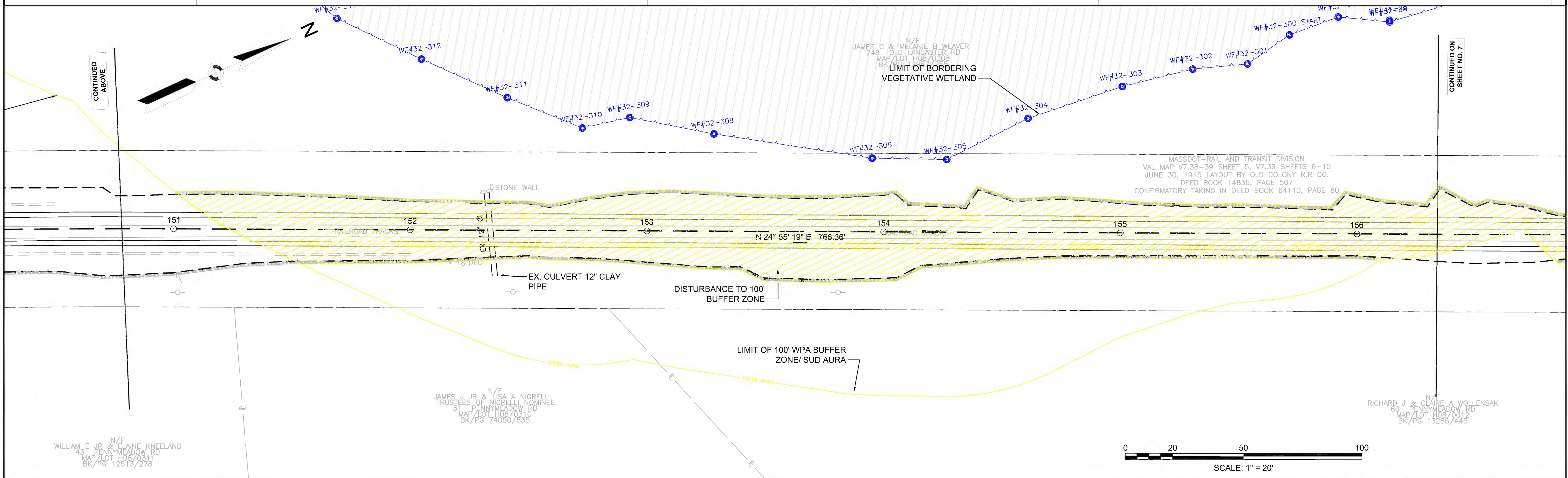
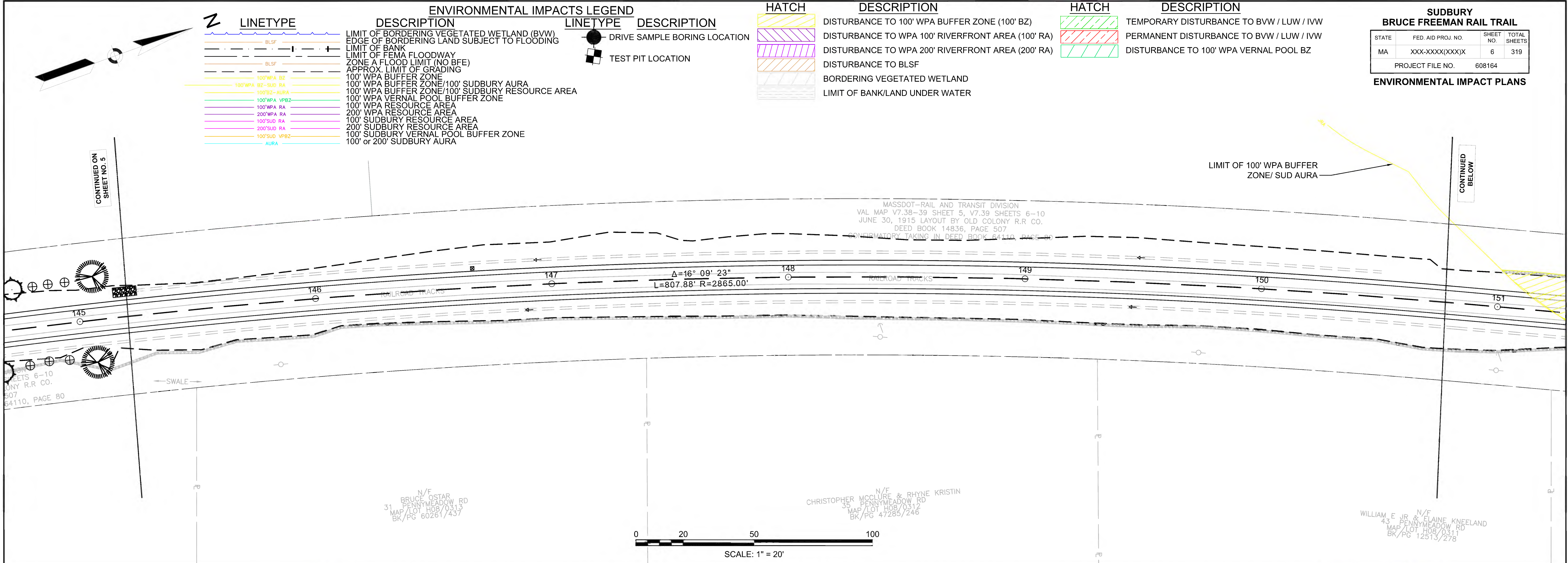

CONTINUED ON SHEET NO. 5

CONTINUED BELOW

CONTINUED ABOVE

CONTINUED ON SHEET NO. 7

ENVIRONMENTAL IMPACTS LEGEND		HATCH		HATCH	
LINETYPE	DESCRIPTION	LINETYPE	DESCRIPTION	HATCH	DESCRIPTION
(Blue dashed line)	LIMIT OF BORDERING VEGETATED WETLAND (BVW)	(Blue diagonal lines)	DISTURBANCE TO 100' WPA BUFFER ZONE (100' BZ)	(Green diagonal lines)	TEMPORARY DISTURBANCE TO BVW / LUW / IWV
(Black dashed line)	EDGE OF BORDERING LAND SUBJECT TO FLOODING	(Purple diagonal lines)	DISTURBANCE TO WPA 100' RIVERFRONT AREA (100' RA)	(Red diagonal lines)	PERMANENT DISTURBANCE TO BVW / LUW / IWV
(Black dashed line)	LIMIT OF BANK	(Pink diagonal lines)	DISTURBANCE TO WPA 200' RIVERFRONT AREA (200' RA)	(Green diagonal lines)	DISTURBANCE TO 100' WPA VERNAL POOL BZ
(Black dashed line)	LIMIT OF FEMA FLOODWAY ZONE A FLOOD LIMIT (NO BFE)	(Black dashed line)	DISTURBANCE TO BLSF	(Blue diagonal lines)	BORDERING VEGETATED WETLAND
(Black dashed line)	APPROX. LIMIT OF GRADING	(Black dashed line)	BORDERING VEGETATED WETLAND	(Blue diagonal lines)	LIMIT OF BANK/LAND UNDER WATER
(Yellow dashed line)	100' WPA BUFFER ZONE	(Black circle)	DRIVE SAMPLE BORING LOCATION		
(Yellow dashed line)	100' WPA BUFFER ZONE/100' SUDBURY AURA	(Black square)	TEST PIT LOCATION		
(Green dashed line)	100' WPA VERNAL POOL BUFFER ZONE				
(Green dashed line)	100' WPA RESOURCE AREA				
(Green dashed line)	200' WPA RESOURCE AREA				
(Green dashed line)	100' SUDBURY RESOURCE AREA				
(Green dashed line)	200' SUDBURY RESOURCE AREA				
(Green dashed line)	100' SUDBURY VERNAL POOL BUFFER ZONE				
(Green dashed line)	100' SUDBURY AURA				

BRUCE FREEMAN RAIL TRAIL			
STATE	FED. AID PROJ. NO.	SHEET NO.	TOTAL SHEETS
MA	XXX-XXXX(XXX)X	7	319
PROJECT FILE NO.		608164	

ENVIRONMENTAL IMPACT PLANS

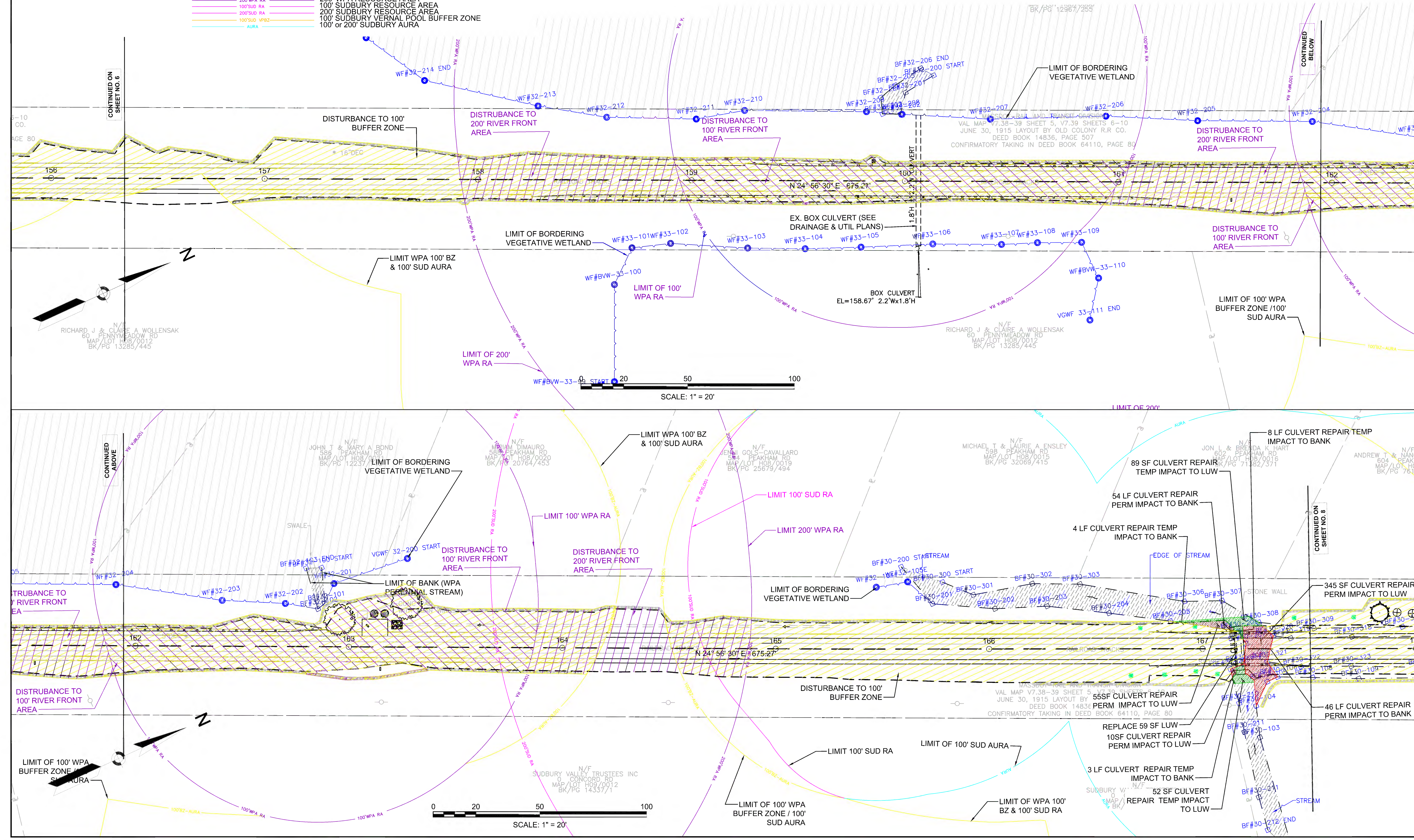

CONTINUED ON SHEET NO. 6

CONTINUED BELOW

CONTINUED ABOVE

CONTINUED ON SHEET NO. 8

LINETYPE	DESCRIPTION	LINETYPE	DESCRIPTION
(Symbol)	LIMIT OF BORDERING VEGETATED WETLAND (BVW)	(Symbol)	DRIVE SAMPLE BORING LOCATION
(Symbol)	EDGE OF BORDERING LAND SUBJECT TO FLOODING	(Symbol)	TEST PIT LOCATION
(Symbol)	LIMIT OF BANK		
(Symbol)	LIMIT OF FEMA FLOODWAY		
(Symbol)	ZONE A FLOOD LIMIT (NO BFE)		
(Symbol)	APPROX. LIMIT OF GRADING		
(Symbol)	100' WPA BUFFER ZONE		
(Symbol)	100' WPA BUFFER ZONE/100' SUDBURY AURA		
(Symbol)	100' WPA BUFFER ZONE/100' SUDBURY RESOURCE AREA		
(Symbol)	100' WPA VERNAL POOL BUFFER ZONE		
(Symbol)	100' WPA RESOURCE AREA		
(Symbol)	200' WPA RESOURCE AREA		
(Symbol)	100' SUDBURY RESOURCE AREA		
(Symbol)	200' SUDBURY RESOURCE AREA		
(Symbol)	100' SUDBURY VERNAL POOL BUFFER ZONE		
(Symbol)	100' SUDBURY VERNAL POOL BUFFER ZONE		
(Symbol)	100' SUDBURY AURA		

HATCH	DESCRIPTION
(Symbol)	DISTURBANCE TO 100' WPA BUFFER ZONE (100' BZ)
(Symbol)	DISTURBANCE TO WPA 100' RIVERFRONT AREA (100' RA)
(Symbol)	DISTURBANCE TO WPA 200' RIVERFRONT AREA (200' RA)
(Symbol)	DISTURBANCE TO BLSF
(Symbol)	BORDERING VEGETATED WETLAND
(Symbol)	LIMIT OF BANK/LAND UNDER WATER

HATCH	DESCRIPTION
(Symbol)	TEMPORARY DISTURBANCE TO BVW / LUW / IWV
(Symbol)	PERMANENT DISTURBANCE TO BVW / LUW / IWV
(Symbol)	DISTURBANCE TO 100' WPA VERNAL POOL BZ

SUDBURY BRUCE FREEMAN RAIL TRAIL			
STATE	FED. AID PROJ. NO.	SHEET NO.	TOTAL SHEETS
MA	XXX-XXXX(XXX)X	8	319
PROJECT FILE NO.		608164	
ENVIRONMENTAL IMPACT PLANS			

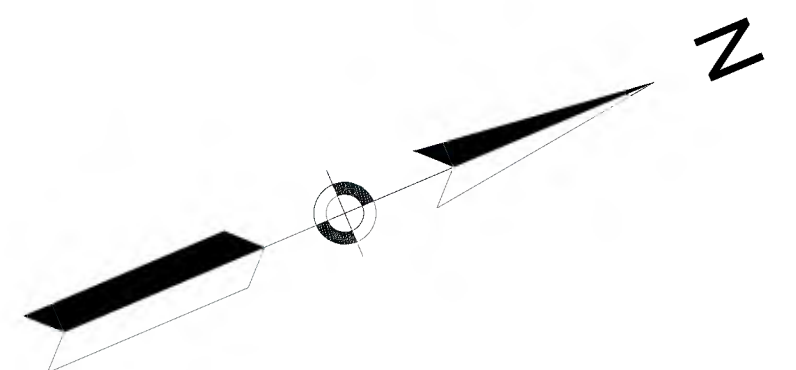
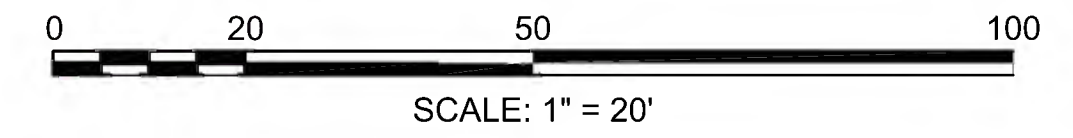
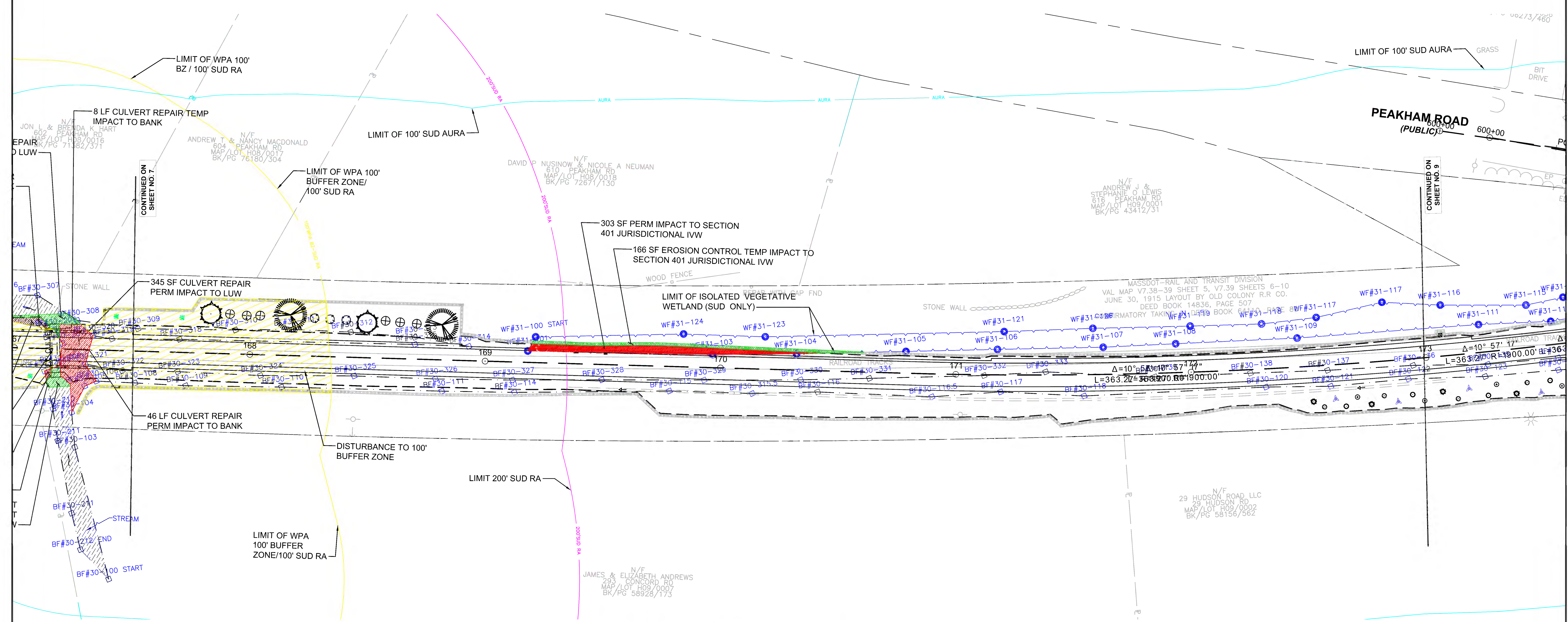

608164_10(0)GENERAL PLANS.DWG Plotted on 18-Feb-2022 4:54 PM

LINETYPE	DESCRIPTION	LINETYPE	DESCRIPTION
	LIMIT OF BORDERING VEGETATED WETLAND (BVW)		DRIVE SAMPLE BORING LOCATION
	EDGE OF BORDERING LAND SUBJECT TO FLOODING		TEST PIT LOCATION
	LIMIT OF BANK		
	LIMIT OF FEMA FLOODWAY		
	ZONE A FLOOD LIMIT (NO BFE)		
	APPROX. LIMIT OF GRADING		
	100' WPA BUFFER ZONE		
	100' WPA BUFFER ZONE/100' SUDBURY AURA		
	100' WPA RA		
	100' WPA VERNAL POOL BUFFER ZONE		
	100' WPA RESOURCE AREA		
	200' WPA RESOURCE AREA		
	100' SUDBURY RESOURCE AREA		
	200' SUDBURY RESOURCE AREA		
	100' SUDBURY VERNAL POOL BUFFER ZONE		
	100' SUDBURY AURA		

HATCH	DESCRIPTION
	DISTURBANCE TO 100' WPA BUFFER ZONE (100' BZ)
	DISTURBANCE TO WPA 100' RIVERFRONT AREA (100' RA)
	DISTURBANCE TO WPA 200' RIVERFRONT AREA (200' RA)
	DISTURBANCE TO BLSF
	BORDERING VEGETATED WETLAND
	LIMIT OF BANK/LAND UNDER WATER

HATCH	DESCRIPTION
	TEMPORARY DISTURBANCE TO BVW / LUW / IVW
	PERMANENT DISTURBANCE TO BVW / LUW / IVW
	DISTURBANCE TO 100' WPA VERNAL POOL BZ

SUDBURY BRUCE FREEMAN RAIL TRAIL			
STATE	FED. AID PROJ. NO.	SHEET NO.	TOTAL SHEETS
MA	XXX-XXXX(XXX)X	9	319
PROJECT FILE NO.		608164	
ENVIRONMENTAL IMPACT PLANS			

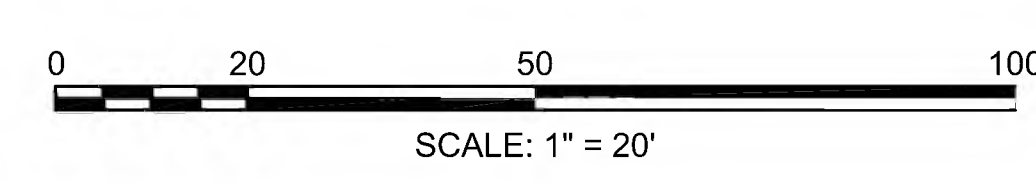
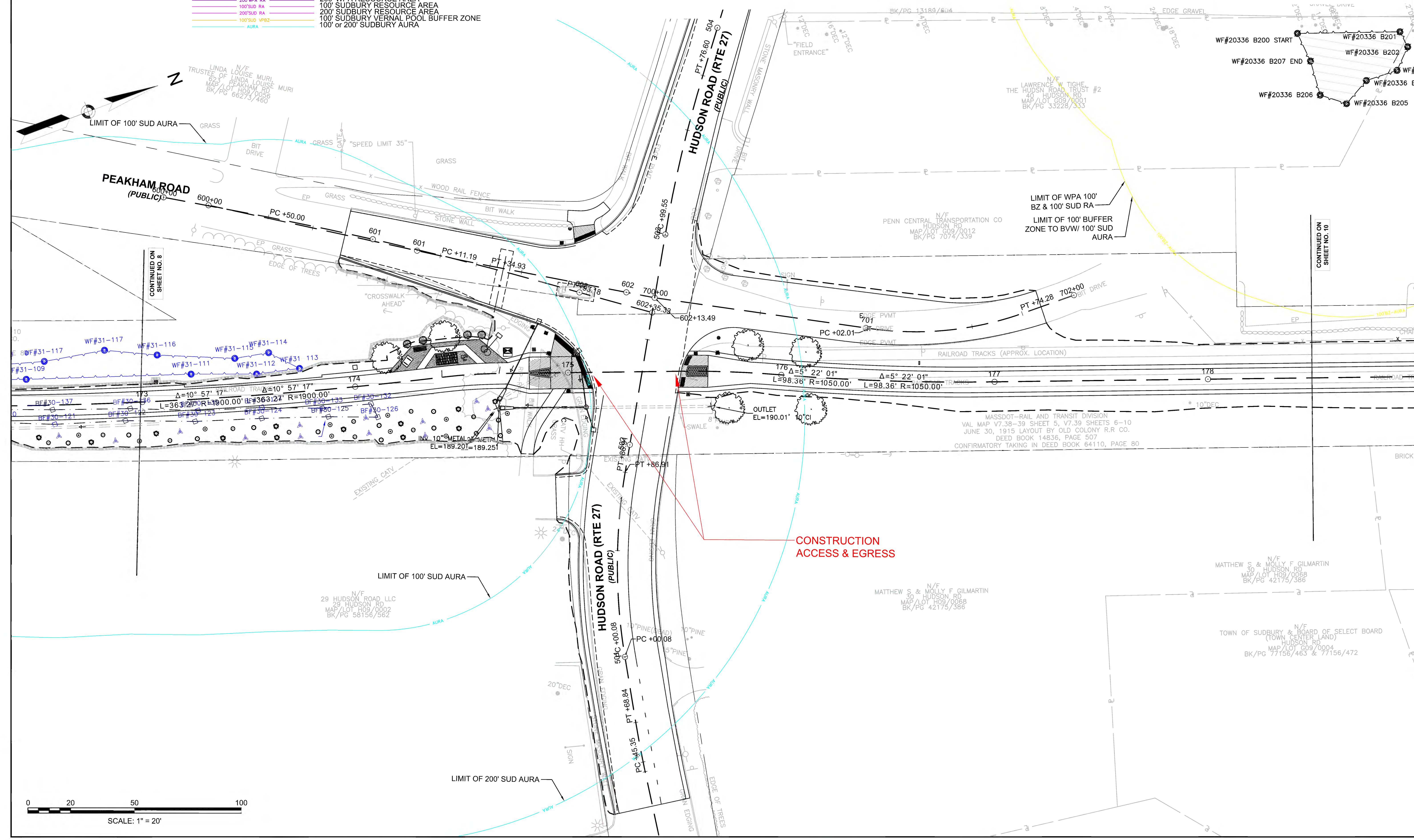

Plotted on 18-Feb-2022 4:55 PM
608164_I01(GENERAL PLANS).DWG

BRUCE FREEMAN RAIL TRAIL			
STATE	FED. AID PROJ. NO.	SHEET NO.	TOTAL SHEETS
MA	XXX-XXXX(XXX)X	11	319
PROJECT FILE NO.		608164	

ENVIRONMENTAL IMPACT PLANS

ENVIRONMENTAL IMPACTS LEGEND	
LINETYPE	DESCRIPTION
	LIMIT OF BORDERING VEGETATED WETLAND (BVW)
	EDGE OF BORDERING LAND SUBJECT TO FLOODING
	LIMIT OF BANK
	LIMIT OF FEMA FLOODWAY ZONE A FLOOD LIMIT (NO BFE)
	APPROX. LIMIT OF GRADING
	100' WPA BUFFER ZONE
	100' WPA BUFFER ZONE/100' SUDBURY AURA
	100' WPA BUFFER ZONE/100' SUDBURY RESOURCE AREA
	100' WPA VERNAL POOL BUFFER ZONE
	100' WPA RESOURCE AREA
	200' WPA RESOURCE AREA
	100' SUDBURY RESOURCE AREA
	200' SUDBURY RESOURCE AREA
	100' SUDBURY VERNAL POOL BUFFER ZONE
	100' SUDBURY AURA

HATCH	DESCRIPTION
	DISTURBANCE TO 100' WPA BUFFER ZONE (100' BZ)
	DISTURBANCE TO WPA 100' RIVERFRONT AREA (100' RA)
	DISTURBANCE TO WPA 200' RIVERFRONT AREA (200' RA)
	DISTURBANCE TO BLSF
	BORDERING VEGETATED WETLAND
	LIMIT OF BANK/LAND UNDER WATER

HATCH	DESCRIPTION
	TEMPORARY DISTURBANCE TO BVW / LUW / IVW
	PERMANENT DISTURBANCE TO BVW / LUW / IVW
	DISTURBANCE TO 100' WPA VERNAL POOL BZ

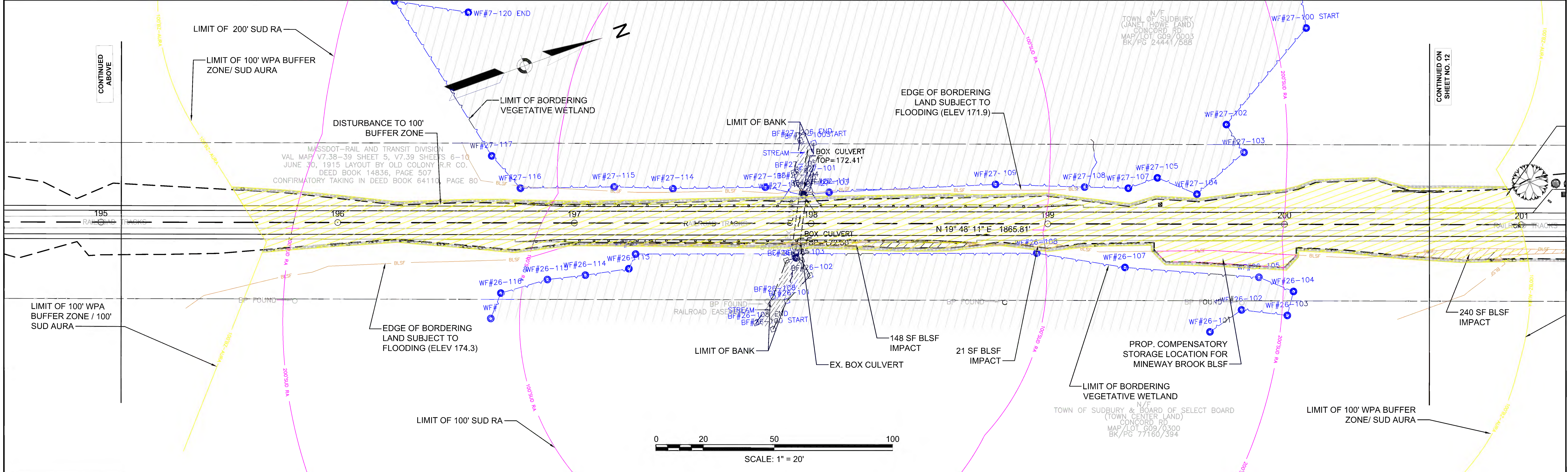
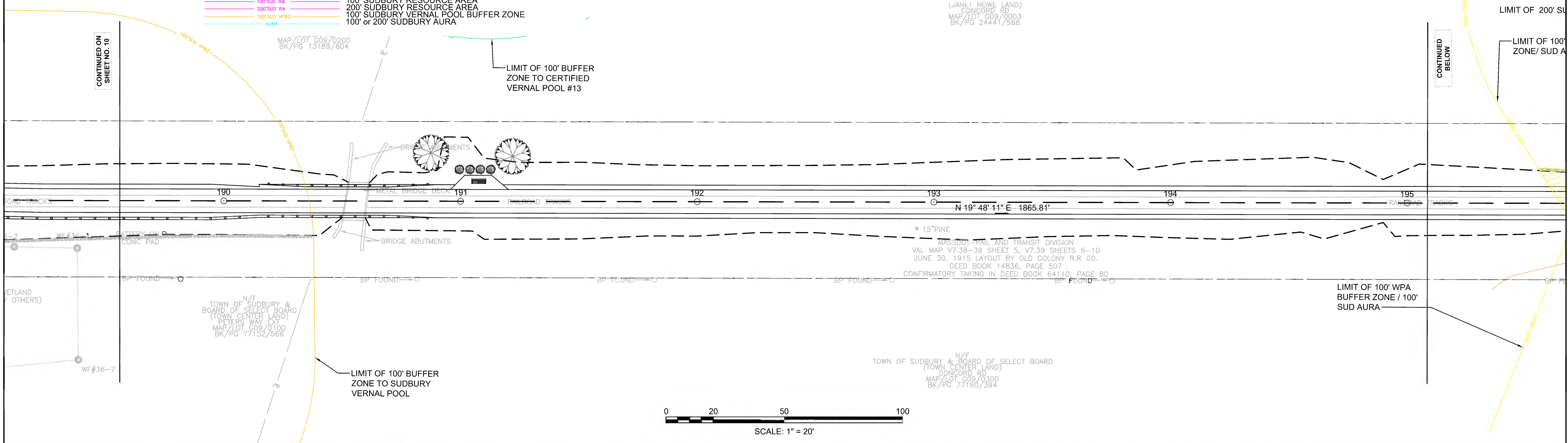

SUDBURY BRUCE FREEMAN RAIL TRAIL			
STATE	FED. AID PROJ. NO.	SHEET NO.	TOTAL SHEETS
MA	XXX-XXXX(XXX)X	12	319
PROJECT FILE NO.		608164	

ENVIRONMENTAL IMPACT PLANS

LINETYPE	DESCRIPTION	LINETYPE	DESCRIPTION	HATCH	DESCRIPTION	HATCH	DESCRIPTION
(Symbol)	LIMIT OF BORDERING VEGETATED WETLAND (BVW)	(Symbol)	DRIVE SAMPLE BORING LOCATION	(Symbol)	DISTURBANCE TO 100' WPA BUFFER ZONE (100' BZ)	(Symbol)	TEMPORARY DISTURBANCE TO BVW / LUW / IVW
(Symbol)	EDGE OF BORDERING LAND SUBJECT TO FLOODING	(Symbol)	TEST PIT LOCATION	(Symbol)	DISTURBANCE TO WPA 100' RIVERFRONT AREA (100' RA)	(Symbol)	PERMANENT DISTURBANCE TO BVW / LUW / IVW
(Symbol)	LIMIT OF FEMA FLOODWAY ZONE A FLOOD LIMIT (NO BFE)			(Symbol)	DISTURBANCE TO WPA 200' RIVERFRONT AREA (200' RA)	(Symbol)	DISTURBANCE TO 100' WPA VERNAL POOL BZ
(Symbol)	APPROX. LIMIT OF GRADING			(Symbol)	DISTURBANCE TO BLSF		
(Symbol)	100' WPA BUFFER ZONE			(Symbol)	BORDERING VEGETATED WETLAND		
(Symbol)	100' WPA BUFFER ZONE/100' SUDBURY AURA			(Symbol)	LIMIT OF BANK/LAND UNDER WATER		
(Symbol)	100' WPA BUFFER ZONE/100' SUDBURY RESOURCE AREA						
(Symbol)	100' WPA VERNAL POOL BUFFER ZONE						
(Symbol)	100' WPA RESOURCE AREA						
(Symbol)	200' WPA RESOURCE AREA						
(Symbol)	100' SUDBURY RESOURCE AREA						
(Symbol)	200' SUDBURY RESOURCE AREA						
(Symbol)	100' SUDBURY VERNAL POOL BUFFER ZONE						
(Symbol)	100' SUDBURY VERNAL POOL BUFFER ZONE						
(Symbol)	AURA						

(JANELI HOWE LAND)
CONCORD RD
MAP/LOT 099/0003
BK/PG 24441/588

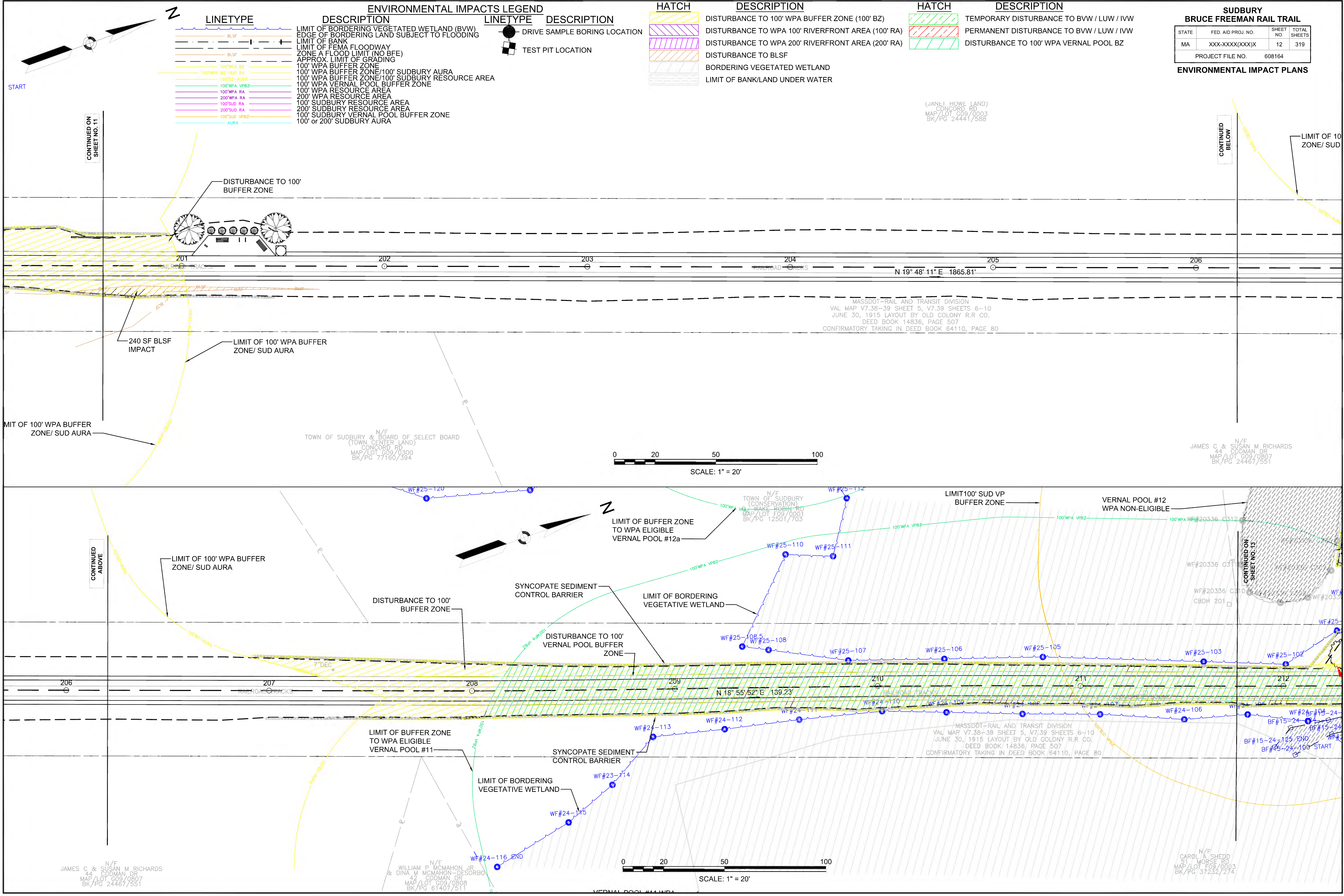

CONTINUED ON
SHEET NO. 11

CONTINUED
BELOW

LIMIT OF 10
ZONE/ SUD

MASSDOT-RAIL AND TRANSIT DIVISION
VAL MAP V7.38-39 SHEET 5, V7.39 SHEETS 6-10
JUNE 30, 1915 LAYOUT BY OLD COLONY R.R. CO.
DEED BOOK 14836, PAGE 507
CONFIRMATORY TAKING IN DEED BOOK 64110, PAGE 80

N/F
TOWN OF SUDBURY & BOARD OF SELECT BOARD
(TOWN CENTER LAND)
CONCORD RD
MAP/LOT 009/0300
BK/PG 77160/394

N/F
JAMES C & SUSAN M RICHARDS
44 CODMAN DR
MAP/LOT 008/0907
BK/PG 24467/551

N/F
TOWN OF SUDBURY
(CONSERVATION)
WAKE-ROBIN RD
MAP/LOT F09/0001
BK/PG 12501/703

MASSDOT-RAIL AND TRANSIT DIVISION
VAL MAP V7.38-39 SHEET 5, V7.39 SHEETS 6-10
JUNE 30, 1915 LAYOUT BY OLD COLONY R.R. CO.
DEED BOOK 14836, PAGE 507
CONFIRMATORY TAKING IN DEED BOOK 64110, PAGE 80

N/F
JAMES C & SUSAN M RICHARDS
44 CODMAN DR
MAP/LOT 009/0807
BK/PG 24467/551

N/F
WILLIAM P MCMAHON JR
& DINA M MCMAHON-DESORBO
42 CODMAN DR
MAP/LOT 009/0808
BK/PG 61407/511

N/F
CAROL A SHEDD
51 MORSE RD
MAP/LOT F09/0003
BK/PG 37232/274

SUDBURY BRUCE FREEMAN RAIL TRAIL			
STATE	FED. AID PROJ. NO.	SHEET NO.	TOTAL SHEETS
MA	XXX-XXXX(XXX)X	13	319
PROJECT FILE NO.		608164	

ENVIRONMENTAL IMPACT PLANS

LINETYPE	DESCRIPTION	LINETYPE	DESCRIPTION
(Symbol)	LIMIT OF BORDERING VEGETATED WETLAND (BVW)	(Symbol)	DRIVE SAMPLE BORING LOCATION
(Symbol)	EDGE OF BORDERING LAND SUBJECT TO FLOODING	(Symbol)	TEST PIT LOCATION
(Symbol)	LIMIT OF BANK		
(Symbol)	LIMIT OF FEMA FLOODWAY ZONE A FLOOD LIMIT (NO BFE)		
(Symbol)	APPROX. LIMIT OF GRADING		
(Symbol)	100' WPA BUFFER ZONE		
(Symbol)	100' WPA BUFFER ZONE/100' SUDBURY AURA		
(Symbol)	100' WPA BUFFER ZONE/100' SUDBURY RESOURCE AREA		
(Symbol)	100' WPA VERNAL POOL BUFFER ZONE		
(Symbol)	100' WPA RESOURCE AREA		
(Symbol)	200' WPA RESOURCE AREA		
(Symbol)	100' SUDBURY RESOURCE AREA		
(Symbol)	200' SUDBURY RESOURCE AREA		
(Symbol)	100' SUDBURY VERNAL POOL BUFFER ZONE		
(Symbol)	100' SUDBURY AURA		

HATCH	DESCRIPTION	HATCH	DESCRIPTION
(Symbol)	DISTURBANCE TO 100' WPA BUFFER ZONE (100' BZ)	(Symbol)	TEMPORARY DISTURBANCE TO BVW / LUW / IVW
(Symbol)	DISTURBANCE TO WPA 100' RIVERFRONT AREA (100' RA)	(Symbol)	PERMANENT DISTURBANCE TO BVW / LUW / IVW
(Symbol)	DISTURBANCE TO WPA 200' RIVERFRONT AREA (200' RA)	(Symbol)	DISTURBANCE TO 100' WPA VERNAL POOL BZ
(Symbol)	DISTURBANCE TO BLSF		
(Symbol)	BORDERING VEGETATED WETLAND		
(Symbol)	LIMIT OF BANK/LAND UNDER WATER		

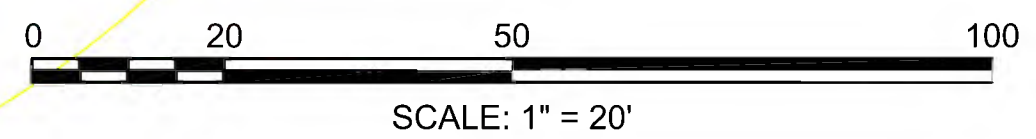
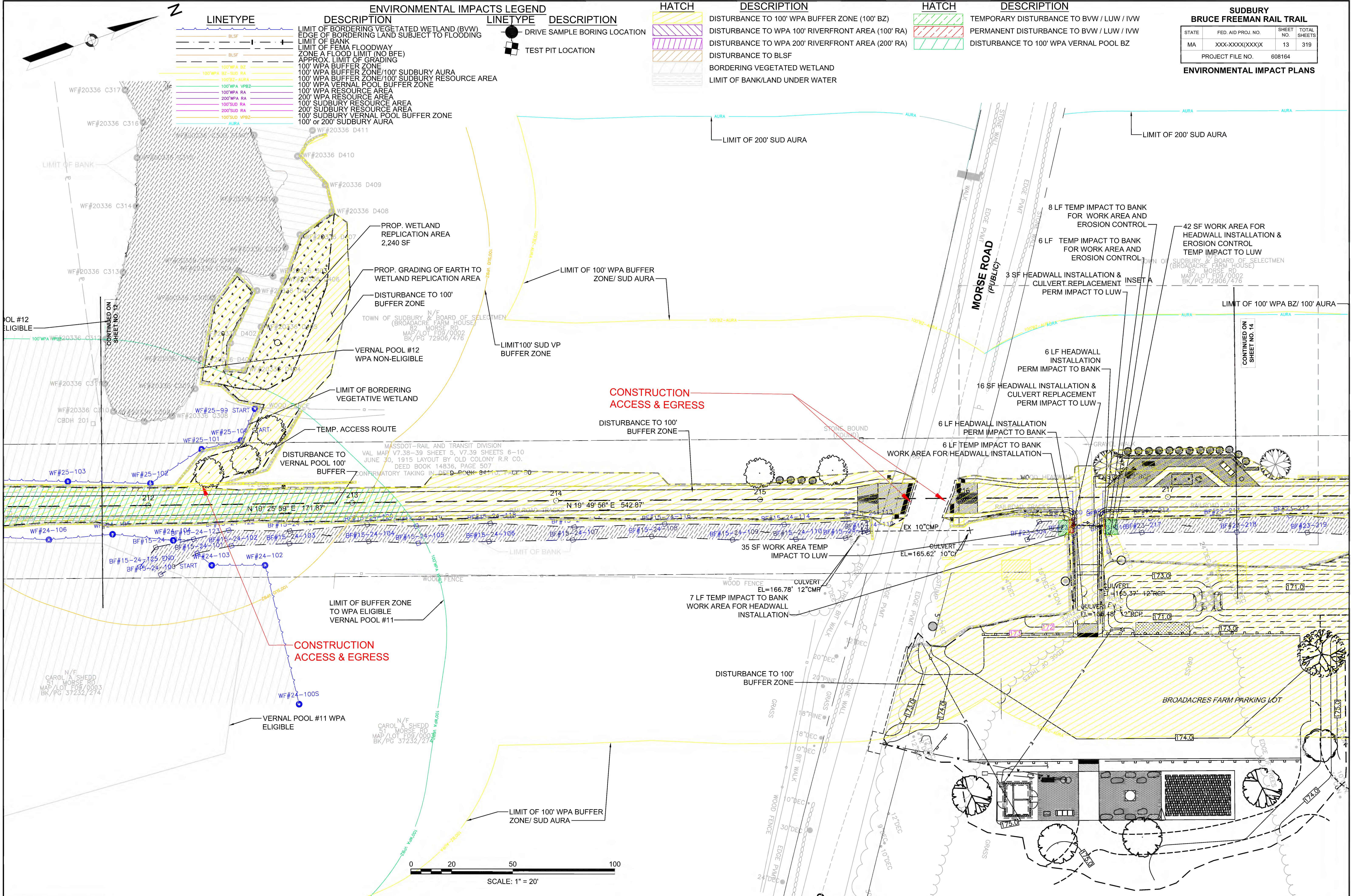

CONTINUED ON SHEET NO. 12

CONTINUED ON SHEET NO. 14

SUDBURY BRUCE FREEMAN RAIL TRAIL			
STATE	FED. AID PROJ. NO.	SHEET NO.	TOTAL SHEETS
MA	XXX-XXX(XXX)X	14	319
PROJECT FILE NO.		608164	

ENVIRONMENTAL IMPACT PLANS

ENVIRONMENTAL IMPACTS LEGEND		HATCH		HATCH	
LINETYPE	DESCRIPTION	HATCH	DESCRIPTION	HATCH	DESCRIPTION
	LIMIT OF BORDERING VEGETATED WETLAND (BVW)		DISTURBANCE TO 100' WPA BUFFER ZONE (100' BZ)		TEMPORARY DISTURBANCE TO BVW / LUW / IWV
	EDGE OF BORDERING LAND SUBJECT TO FLOODING		DISTURBANCE TO WPA 100' RIVERFRONT AREA (100' RA)		PERMANENT DISTURBANCE TO BVW / LUW / IWV
	LIMIT OF BANK		DISTURBANCE TO WPA 200' RIVERFRONT AREA (200' RA)		DISTURBANCE TO 100' WPA VERNAL POOL BZ
	LIMIT OF FEMA FLOODWAY ZONE A FLOOD LIMIT (NO BFE)		DISTURBANCE TO BLSF		
	APPROX. LIMIT OF GRADING		BORDERING VEGETATED WETLAND		
	100' WPA BUFFER ZONE		LIMIT OF BANK/LAND UNDER WATER		
	100' WPA BUFFER ZONE/100' SUDBURY AURA				
	100' WPA VERNAL POOL BUFFER ZONE				
	100' WPA RESOURCE AREA				
	200' WPA RESOURCE AREA				
	100' SUDBURY RESOURCE AREA				
	200' SUDBURY RESOURCE AREA				
	100' SUDBURY VERNAL POOL BUFFER ZONE				
	100' SUDBURY AURA				
	200' SUDBURY AURA				

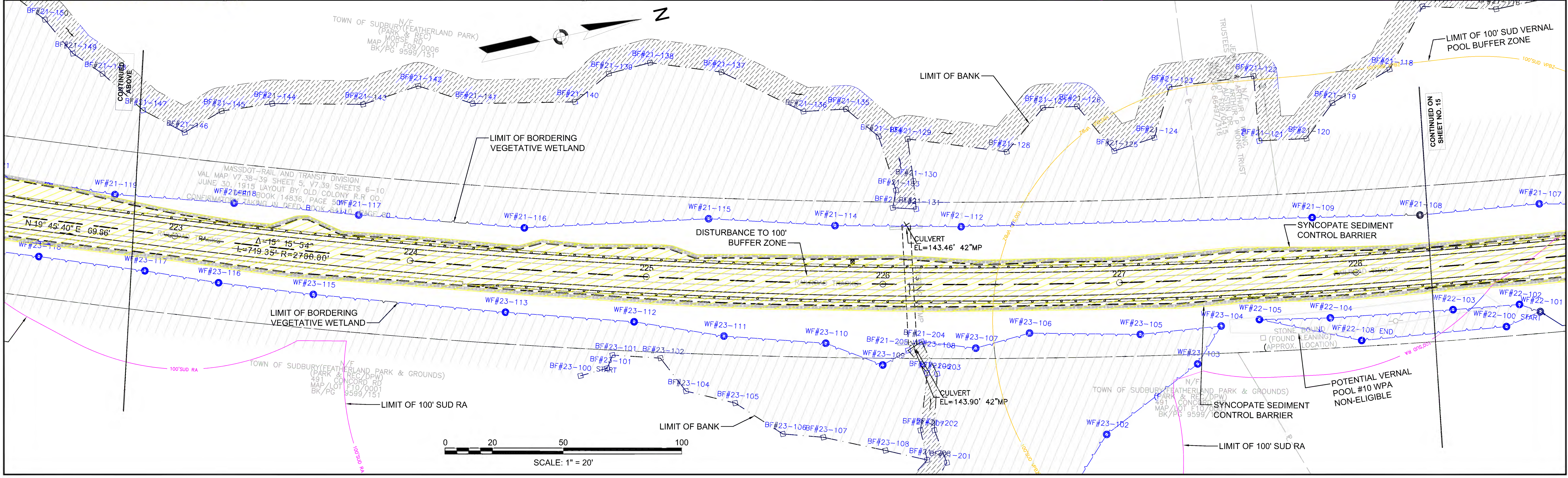
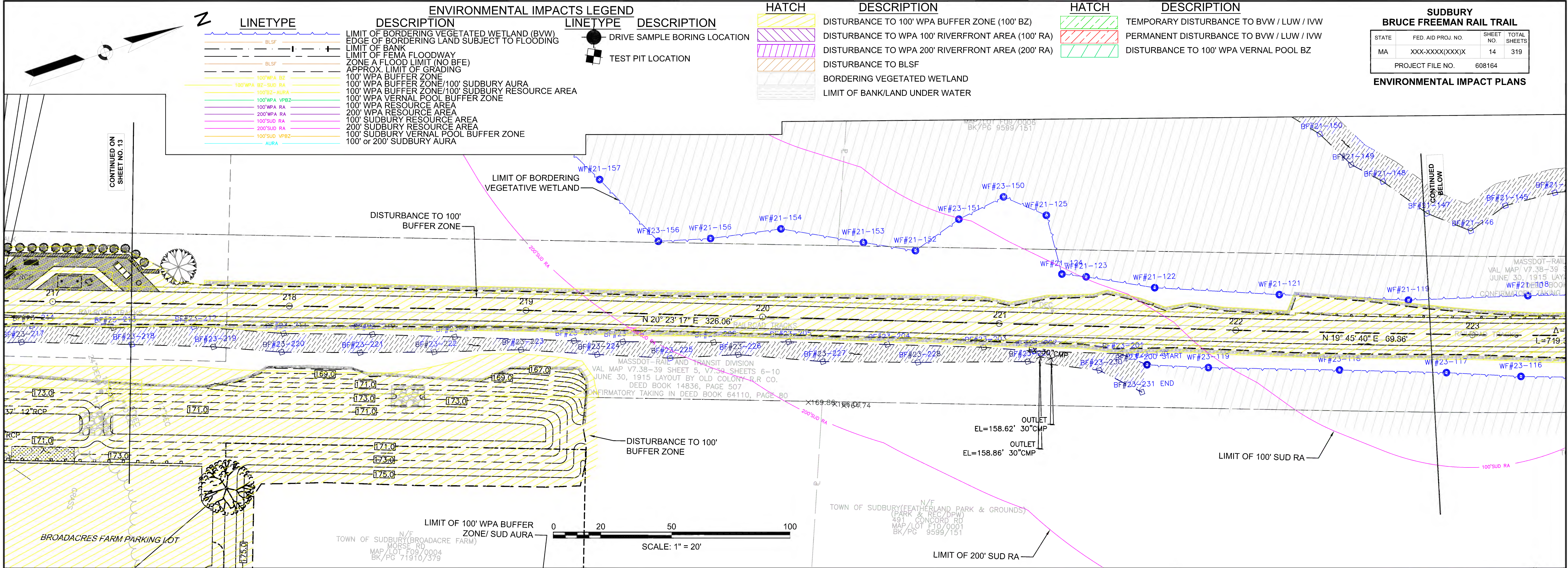

CONTINUED ON SHEET NO. 13

CONTINUED BELOW

CONTINUED ABOVE

CONTINUED ON SHEET NO. 15

LINETYPE	DESCRIPTION
(Symbol)	LIMIT OF BORDERING VEGETATED WETLAND (BVW)
(Symbol)	EDGE OF BORDERING LAND SUBJECT TO FLOODING
(Symbol)	LIMIT OF BANK
(Symbol)	LIMIT OF FEMA FLOODWAY ZONE A FLOOD LIMIT (NO BFE)
(Symbol)	APPROX. LIMIT OF GRADING
(Symbol)	100' WPA BUFFER ZONE
(Symbol)	100' WPA BUFFER ZONE/100' SUDBURY AURA
(Symbol)	100' WPA BUFFER ZONE/100' SUDBURY RESOURCE AREA
(Symbol)	100' WPA VERNAL POOL BUFFER ZONE
(Symbol)	100' WPA RESOURCE AREA
(Symbol)	200' WPA RESOURCE AREA
(Symbol)	100' SUDBURY RESOURCE AREA
(Symbol)	200' SUDBURY RESOURCE AREA
(Symbol)	100' SUDBURY VERNAL POOL BUFFER ZONE
(Symbol)	100' SUDBURY VERNAL POOL BUFFER ZONE
(Symbol)	100' SUDBURY AURA

LINETYPE	DESCRIPTION
(Symbol)	DRIVE SAMPLE BORING LOCATION
(Symbol)	TEST PIT LOCATION

HATCH	DESCRIPTION
(Symbol)	DISTURBANCE TO 100' WPA BUFFER ZONE (100' BZ)
(Symbol)	DISTURBANCE TO WPA 100' RIVERFRONT AREA (100' RA)
(Symbol)	DISTURBANCE TO WPA 200' RIVERFRONT AREA (200' RA)
(Symbol)	DISTURBANCE TO BLSF
(Symbol)	BORDERING VEGETATED WETLAND
(Symbol)	LIMIT OF BANK/LAND UNDER WATER

HATCH	DESCRIPTION
(Symbol)	TEMPORARY DISTURBANCE TO BVW / LUW / IVW
(Symbol)	PERMANENT DISTURBANCE TO BVW / LUW / IVW
(Symbol)	DISTURBANCE TO 100' WPA VERNAL POOL BZ

BRUCE FREEMAN RAIL TRAIL			
STATE	FED. AID PROJ. NO.	SHEET NO.	TOTAL SHEETS
MA	XXX-XXX(XXX)X	15	319
PROJECT FILE NO.		608164	

ENVIRONMENTAL IMPACT PLANS

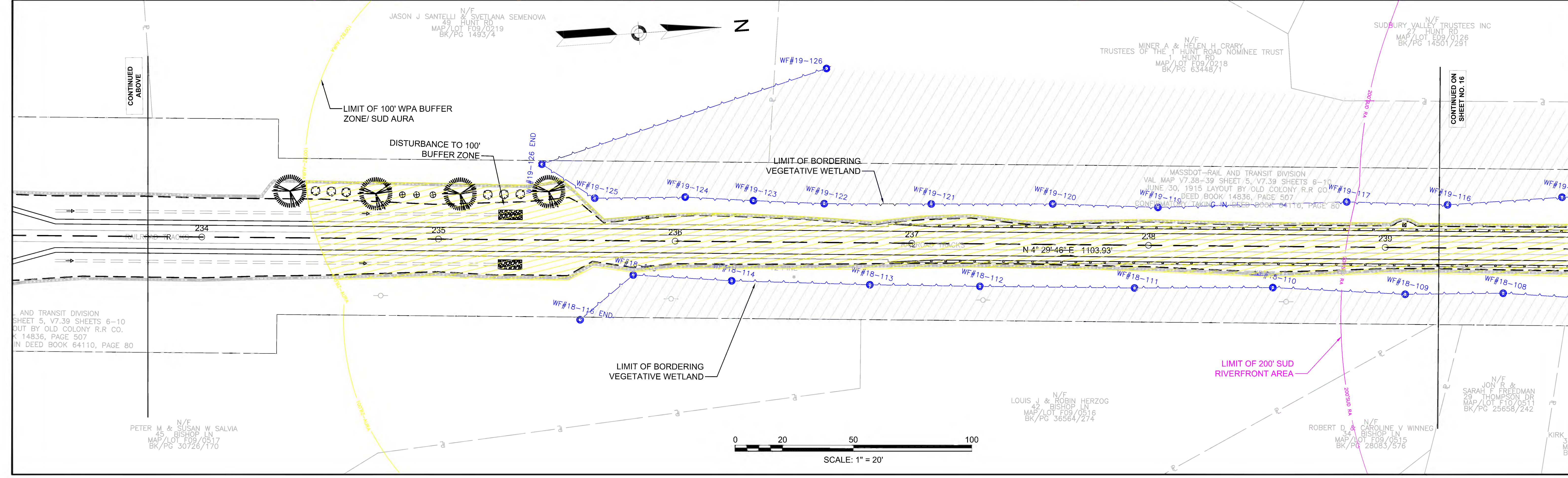
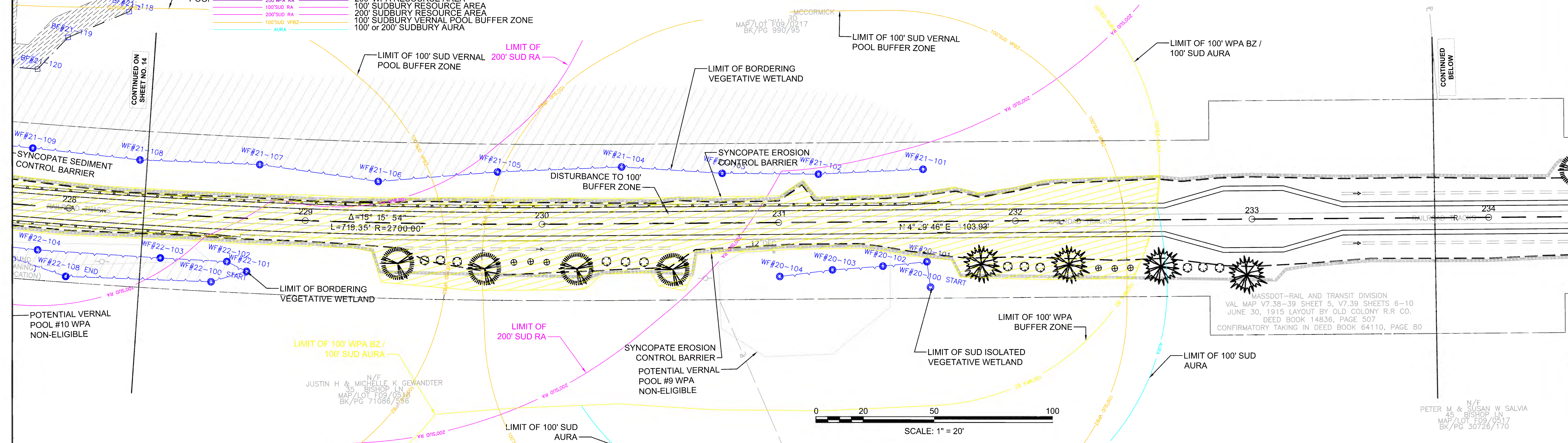

608164_NOI(GENERAL PLANS).DWG Plotted on 16-Feb-2022 4:57 PM

LINETYPE	DESCRIPTION	LINETYPE	DESCRIPTION
(Symbol)	LIMIT OF BORDERING VEGETATED WETLAND (BVW)	(Symbol)	DRIVE SAMPLE BORING LOCATION
(Symbol)	EDGE OF BORDERING LAND SUBJECT TO FLOODING	(Symbol)	TEST PIT LOCATION
(Symbol)	LIMIT OF BANK		
(Symbol)	LIMIT OF FEMA FLOODWAY		
(Symbol)	ZONE A FLOOD LIMIT (NO BFE)		
(Symbol)	APPROX. LIMIT OF GRADING		
(Symbol)	100' WPA BUFFER ZONE		
(Symbol)	100' WPA BUFFER ZONE/100' SUDBURY AURA		
(Symbol)	100' WPA BUFFER ZONE/100' SUDBURY RESOURCE AREA		
(Symbol)	100' WPA VERNAL POOL BUFFER ZONE		
(Symbol)	100' WPA RESOURCE AREA		
(Symbol)	200' WPA RESOURCE AREA		
(Symbol)	100' SUDBURY RESOURCE AREA		
(Symbol)	200' SUDBURY RESOURCE AREA		
(Symbol)	100' SUDBURY VERNAL POOL BUFFER ZONE		
(Symbol)	100' SUDBURY AURA		

HATCH	DESCRIPTION
(Hatch)	DISTURBANCE TO 100' WPA BUFFER ZONE (100' BZ)
(Hatch)	DISTURBANCE TO WPA 100' RIVERFRONT AREA (100' RA)
(Hatch)	DISTURBANCE TO WPA 200' RIVERFRONT AREA (200' RA)
(Hatch)	DISTURBANCE TO BLSF
(Hatch)	BORDERING VEGETATED WETLAND
(Hatch)	LIMIT OF BANK/LAND UNDER WATER

HATCH	DESCRIPTION
(Hatch)	TEMPORARY DISTURBANCE TO BVW / LUW / IVW
(Hatch)	PERMANENT DISTURBANCE TO BVW / LUW / IVW
(Hatch)	DISTURBANCE TO 100' WPA VERNAL POOL BZ

SUDBURY BRUCE FREEMAN RAIL TRAIL			
STATE	FED. AID PROJ. NO.	SHEET NO.	TOTAL SHEETS
MA	XXX-XXXX(XXX)X	16	319
PROJECT FILE NO.		608164	

ENVIRONMENTAL IMPACT PLANS

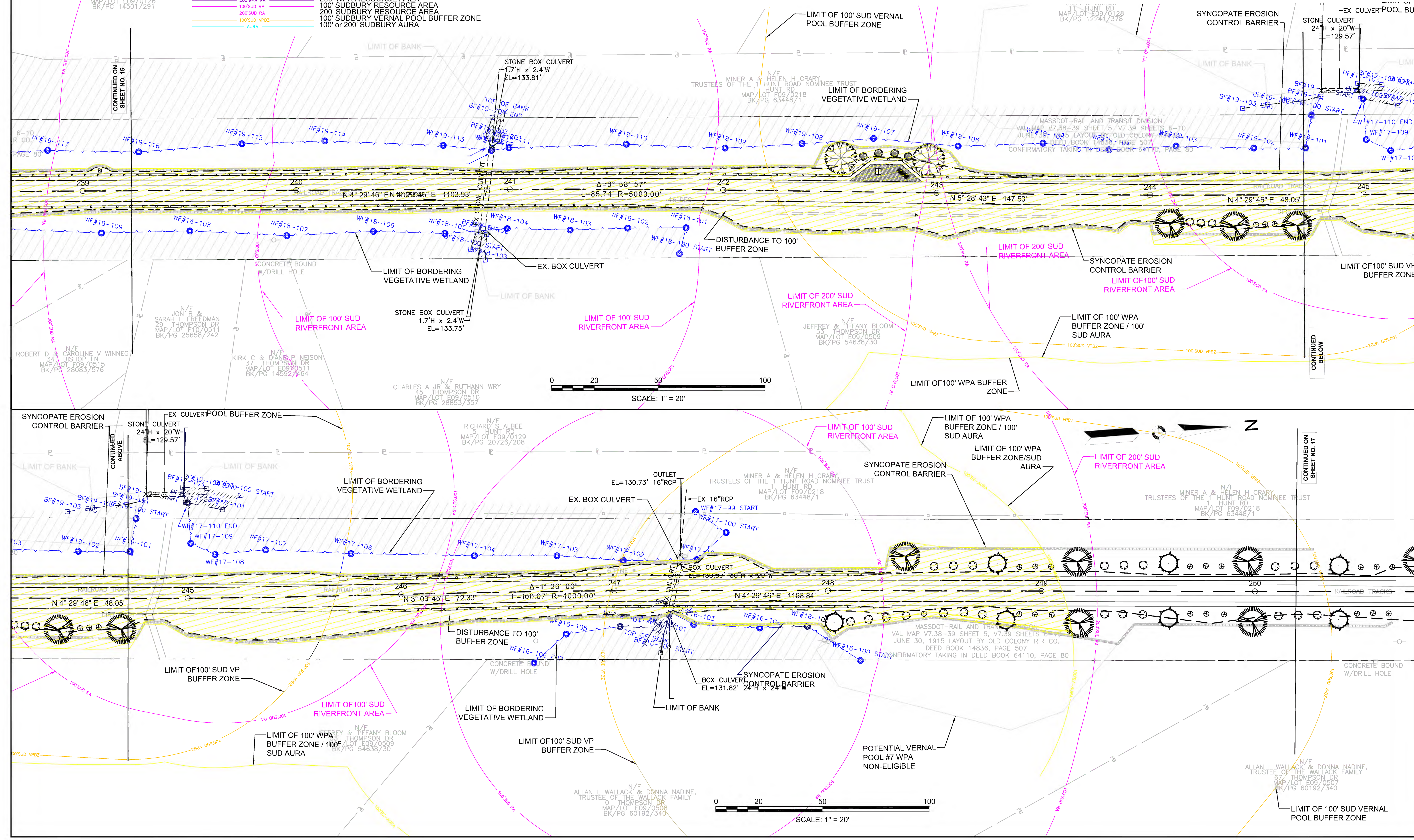

ENVIRONMENTAL IMPACTS LEGEND		HATCH		HATCH	
LINETYPE	DESCRIPTION		DESCRIPTION		DESCRIPTION
	LIMIT OF BORDERING VEGETATED WETLAND (BVW)		DISTURBANCE TO 100' WPA BUFFER ZONE (100' BZ)		TEMPORARY DISTURBANCE TO BVW / LUW / IVW
	EDGE OF BORDERING LAND SUBJECT TO FLOODING		DISTURBANCE TO WPA 100' RIVERFRONT AREA (100' RA)		PERMANENT DISTURBANCE TO BVW / LUW / IVW
	LIMIT OF BANK		DISTURBANCE TO WPA 200' RIVERFRONT AREA (200' RA)		DISTURBANCE TO 100' WPA VERNAL POOL BZ
	LIMIT OF FEMA FLOODWAY		DISTURBANCE TO BLSF		
	ZONE A FLOOD LIMIT (NO BFE)		BORDERING VEGETATED WETLAND		
	APPROX. LIMIT OF GRADING		LIMIT OF BANK/LAND UNDER WATER		
	100' WPA BUFFER ZONE				
	100' WPA BUFFER ZONE/100' SUDBURY AURA				
	100' WPA BUFFER ZONE/100' SUDBURY RESOURCE AREA				
	100' WPA VERNAL POOL BUFFER ZONE				
	100' WPA RESOURCE AREA				
	200' WPA RESOURCE AREA				
	100' SUDBURY RESOURCE AREA				
	200' SUDBURY RESOURCE AREA				
	100' SUDBURY VERNAL POOL BUFFER ZONE				
	100' SUDBURY AURA				
	100' SUDBURY AURA				
	100' SUDBURY AURA				
	100' SUDBURY AURA				
	100' SUDBURY AURA				
	100' SUDBURY AURA				
	100' SUDBURY AURA				
	100' SUDBURY AURA				
	100' SUDBURY AURA				
	100' SUDBURY AURA				
	100' SUDBURY AURA				
	100' SUDBURY AURA				
	100' SUDBURY AURA				
	100' SUDBURY AURA				
	100' SUDBURY AURA				
	100' SUDBURY AURA				
	100' SUDBURY AURA				
	100' SUDBURY AURA				
	100' SUDBURY AURA				
	100' SUDBURY AURA				
	100' SUDBURY AURA				
	100' SUDBURY AURA				
	100' SUDBURY AURA				
	100' SUDBURY AURA				
	100' SUDBURY AURA				
	100' SUDBURY AURA				
	100' SUDBURY AURA				
	100' SUDBURY AURA				
	100' SUDBURY AURA				
	100' SUDBURY AURA				
	100' SUDBURY AURA				
	100' SUDBURY AURA				
	100' SUDBURY AURA				
	100' SUDBURY AURA				
	100' SUDBURY AURA				
	100' SUDBURY AURA				
	100' SUDBURY AURA				
	100' SUDBURY AURA				
	100' SUDBURY AURA				
	100' SUDBURY AURA				
	100' SUDBURY AURA				
	100' SUDBURY AURA				
	100' SUDBURY AURA				
	100' SUDBURY AURA				
	100' SUDBURY AURA				
	100' SUDBURY AURA				
	100' SUDBURY AURA				
	100' SUDBURY AURA				
	100' SUDBURY AURA				
	100' SUDBURY AURA				
	100' SUDBURY AURA				
	100' SUDBURY AURA				
	100' SUDBURY AURA				
	100' SUDBURY AURA				
	100' SUDBURY AURA				
	100' SUDBURY AURA				
	100' SUDBURY AURA				
	100' SUDBURY AURA				
	100' SUDBURY AURA				
	100' SUDBURY AURA				
	100' SUDBURY AURA				
	100' SUDBURY AURA				
	100' SUDBURY AURA				
	100' SUDBURY AURA				
	100' SUDBURY AURA				
	100' SUDBURY AURA				
	100' SUDBURY AURA				
	100' SUDBURY AURA				
	100' SUDBURY AURA				
	100' SUDBURY AURA				
	100' SUDBURY AURA				
	100' SUDBURY AURA				
	100' SUDBURY AURA				
	100' SUDBURY AURA				
	100' SUDBURY AURA				
	100' SUDBURY AURA				
	100' SUDBURY AURA				
	100' SUDBURY AURA				
	100' SUDBURY AURA				
	100' SUDBURY AURA				
	100' SUDBURY AURA				
	100' SUDBURY AURA				
	100' SUDBURY AURA				
	100' SUDBURY AURA				
	100' SUDBURY AURA				
	100' SUDBURY AURA				
	100' SUDBURY AURA				
	100' SUDBURY AURA				
	100' SUDBURY AURA				
	100' SUDBURY AURA				
	100' SUDBURY AURA				
	100' SUDBURY AURA				
	100' SUDBURY AURA				
	100' SUDBURY AURA				
	100' SUDBURY AURA				
	100' SUDBURY AURA				
	100' SUDBURY AURA				
	100' SUDBURY AURA				
	100' SUDBURY AURA				
	100' SUDBURY AURA				
	100' SUDBURY AURA				
	100' SUDBURY AURA				
	100' SUDBURY AURA				
	100' SUDBURY AURA				
	100' SUDBURY AURA				
	100' SUDBURY AURA				
	100' SUDBURY AURA				
	100' SUDBURY AURA				
	100' SUDBURY AURA				
	100' SUDBURY AURA				
	100' SUDBURY AURA				
	100' SUDBURY AURA				
	100' SUDBURY AURA				
	100' SUDBURY AURA				
	100' SUDBURY AURA				
	100' SUDBURY AURA				
	100' SUDBURY AURA				
	100' SUDBURY AURA				
	100' SUDBURY AURA				
	100' SUDBURY AURA				
	100' SUDBURY AURA				
	100' SUDBURY AURA				
	100' SUDBURY AURA				
	100' SUDBURY AURA				
	100' SUDBURY AURA				
	100' SUDBURY AURA				
	100' SUDBURY AURA				
	100' SUDBURY AURA				
	100' SUDBURY AURA				
	100' SUDBURY AURA				
	100' SUDBURY AURA				
	100' SUDBURY AURA				
	100' SUDBURY AURA				
	100' SUDBURY AURA				
	100' SUDBURY AURA				
	100' SUDBURY AURA				
	100' SUDBURY AURA				
	100' SUDBURY AURA				
	100' SUDBURY AURA				
	100' SUDBURY AURA				
	100' SUDBURY AURA				
	100' SUDBURY AURA				
	100' SUDBURY AURA				
	100' SUDBURY AURA				
	100' SUDBURY AURA				
	100' SUDBURY AURA				
	100' SUDBURY AURA				
	100' SUDBURY AURA				
	100' SUDBURY AURA				
	100' SUDBURY AURA				
	100' SUDBURY AURA				
	100' SUDBURY AURA				
	100' SUDBURY AURA				
	100' SUDBURY AURA				
	100' SUDBURY AURA				
	100' SUDBURY AURA				
	100' SUDBURY AURA				
	100' SUDBURY AURA				
	100' SUDBURY AURA				
	100' SUDBURY AURA				
	100' SUDBURY AURA				
	100' SUDBURY AURA				
	100' SUDBURY AURA				
	100' SUDBURY AURA				
	100' SUDBURY AURA				
	100' SUDBURY AURA				
	100' SUDBURY AURA				
	100' SUDBURY AURA				
	100' SUDBURY AURA				
	100' SUDBURY AURA				
	100' SUDBURY AURA				
	100' SUDBURY AURA				
	100' SUDBURY AURA				
	100' SUDBURY AURA				
	100' SUDBURY AURA				
	100' SUDBURY AURA				
	100' SUDBURY AURA				
	100' SUDBURY AURA				
	100' SUDBURY AURA				
	100' SUDBURY AURA				
	100' SUDBURY AURA				
	100' SUDBURY AURA				
	100' SUDBURY AURA				
	100' SUDBURY AURA				
	100' SUDBURY AURA				
	100' SUDBURY AURA				
	100' SUDBURY AURA				
	100' SUDBURY AURA				
	100' SUDBURY AURA				
	100' SUDBURY AURA				
	100' SUDBURY AURA				
	100' SUDBURY AURA				
	100' SUDBURY AURA				
	100' SUDBURY AURA				
	100' SUDBURY AURA				

ENVIRONMENTAL IMPACTS LEGEND		HATCH		HATCH	
LINETYPE	DESCRIPTION	HATCH	DESCRIPTION	HATCH	DESCRIPTION
(Symbol)	LIMIT OF BORDERING VEGETATED WETLAND (BVW)	(Symbol)	DISTURBANCE TO 100' WPA BUFFER ZONE (100' BZ)	(Symbol)	TEMPORARY DISTURBANCE TO BVW / LUW / IWV
(Symbol)	EDGE OF BORDERING LAND SUBJECT TO FLOODING	(Symbol)	DISTURBANCE TO WPA 100' RIVERFRONT AREA (100' RA)	(Symbol)	PERMANENT DISTURBANCE TO BVW / LUW / IWV
(Symbol)	LIMIT OF BANK	(Symbol)	DISTURBANCE TO WPA 200' RIVERFRONT AREA (200' RA)	(Symbol)	DISTURBANCE TO 100' WPA VERNAL POOL BZ
(Symbol)	LIMIT OF FEMA FLOODWAY ZONE A FLOOD LIMIT (NO BFE)	(Symbol)	DISTURBANCE TO BLSF		
(Symbol)	APPROX. LIMIT OF GRADING	(Symbol)	BORDERING VEGETATED WETLAND		
(Symbol)	100' WPA BUFFER ZONE	(Symbol)	LIMIT OF BANK/LAND UNDER WATER		
(Symbol)	100' WPA BUFFER ZONE/100' SUDBURY AURA				
(Symbol)	100' WPA BUFFER ZONE/100' SUDBURY RESOURCE AREA				
(Symbol)	100' WPA VERNAL POOL BUFFER ZONE				
(Symbol)	100' WPA RESOURCE AREA				
(Symbol)	200' WPA RESOURCE AREA				
(Symbol)	100' SUDBURY RESOURCE AREA				
(Symbol)	200' SUDBURY RESOURCE AREA				
(Symbol)	100' SUDBURY VERNAL POOL BUFFER ZONE				
(Symbol)	100' or 200' SUDBURY AURA				
(Symbol)	DRIVE SAMPLE BORING LOCATION				
(Symbol)	TEST PIT LOCATION				

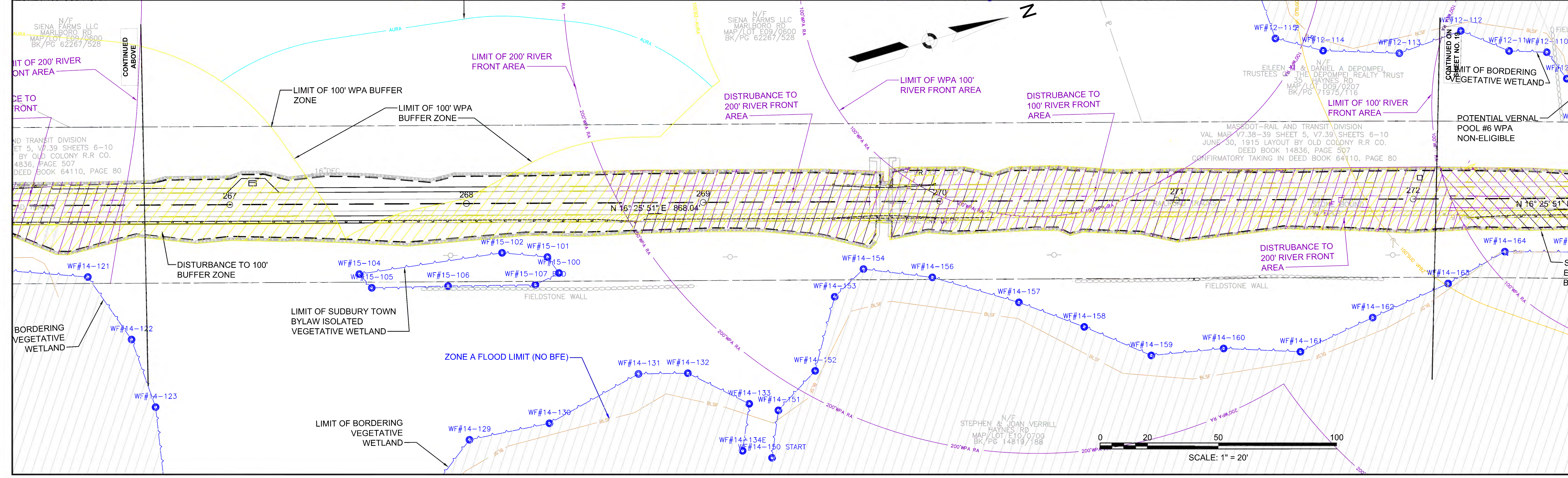
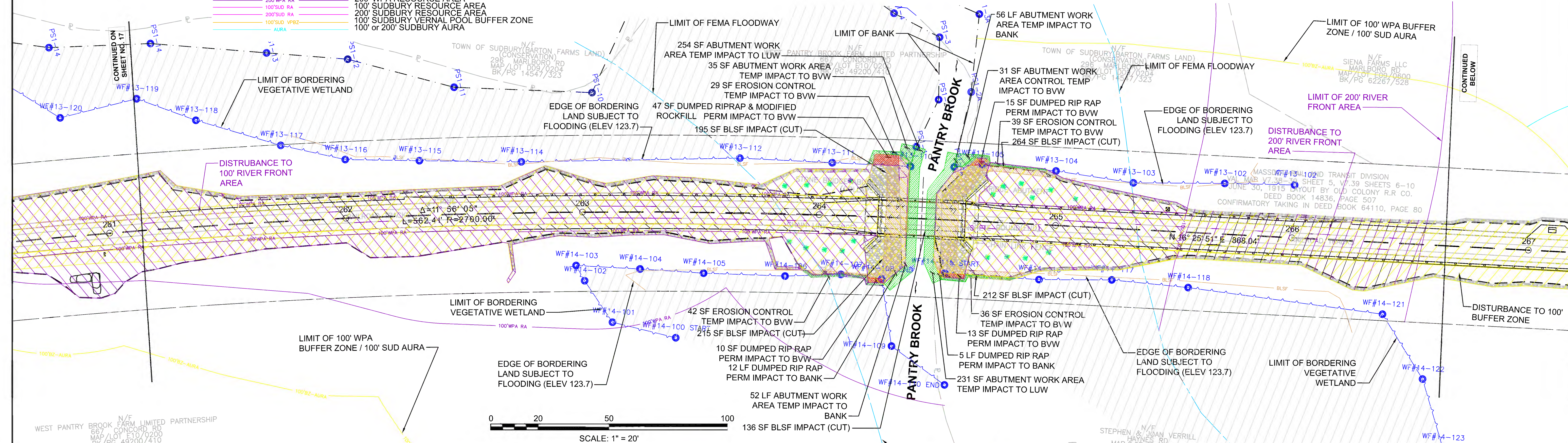

SUDBURY BRUCE FREEMAN RAIL TRAIL			
STATE	FED. AID PROJ. NO.	SHEET NO.	TOTAL SHEETS
MA	XXX-XXXX(XXX)X	19	319
PROJECT FILE NO.		608164	

ENVIRONMENTAL IMPACT PLANS

LINETYPE	DESCRIPTION	LINETYPE	DESCRIPTION	HATCH	DESCRIPTION	HATCH	DESCRIPTION
(Symbol)	LIMIT OF BORDERING VEGETATED WETLAND (BVW)	(Symbol)	DRIVE SAMPLE BORING LOCATION	(Symbol)	DISTURBANCE TO 100' WPA BUFFER ZONE (100' BZ)	(Symbol)	TEMPORARY DISTURBANCE TO BVW / LUW / IVW
(Symbol)	EDGE OF BORDERING LAND SUBJECT TO FLOODING	(Symbol)	TEST PIT LOCATION	(Symbol)	DISTURBANCE TO WPA 100' RIVERFRONT AREA (100' RA)	(Symbol)	PERMANENT DISTURBANCE TO BVW / LUW / IVW
(Symbol)	LIMIT OF BANK			(Symbol)	DISTURBANCE TO WPA 200' RIVERFRONT AREA (200' RA)	(Symbol)	DISTURBANCE TO 100' WPA VERNAL POOL BZ
(Symbol)	ZONE A FLOOD LIMIT (NO BFE)			(Symbol)	DISTURBANCE TO BLSF		
(Symbol)	APPROX. LIMIT OF GRADING			(Symbol)	BORDERING VEGETATED WETLAND		
(Symbol)	100' WPA BUFFER ZONE			(Symbol)	LIMIT OF BANK/LAND UNDER WATER		
(Symbol)	100' WPA BUFFER ZONE/100' SUDBURY AURA						
(Symbol)	100' WPA BUFFER ZONE/100' SUDBURY RESOURCE AREA						
(Symbol)	100' WPA VERNAL POOL BUFFER ZONE						
(Symbol)	100' WPA RESOURCE AREA						
(Symbol)	200' WPA RESOURCE AREA						
(Symbol)	100' SUDBURY RESOURCE AREA						
(Symbol)	200' SUDBURY RESOURCE AREA						
(Symbol)	100' SUDBURY VERNAL POOL BUFFER ZONE						
(Symbol)	100' SUDBURY AURA						

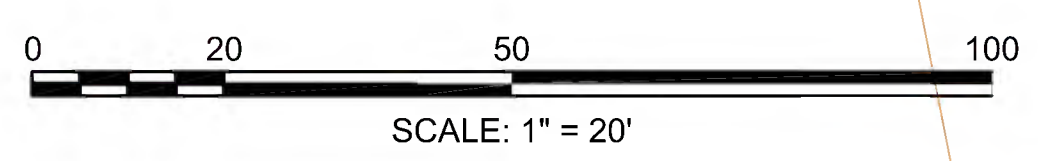
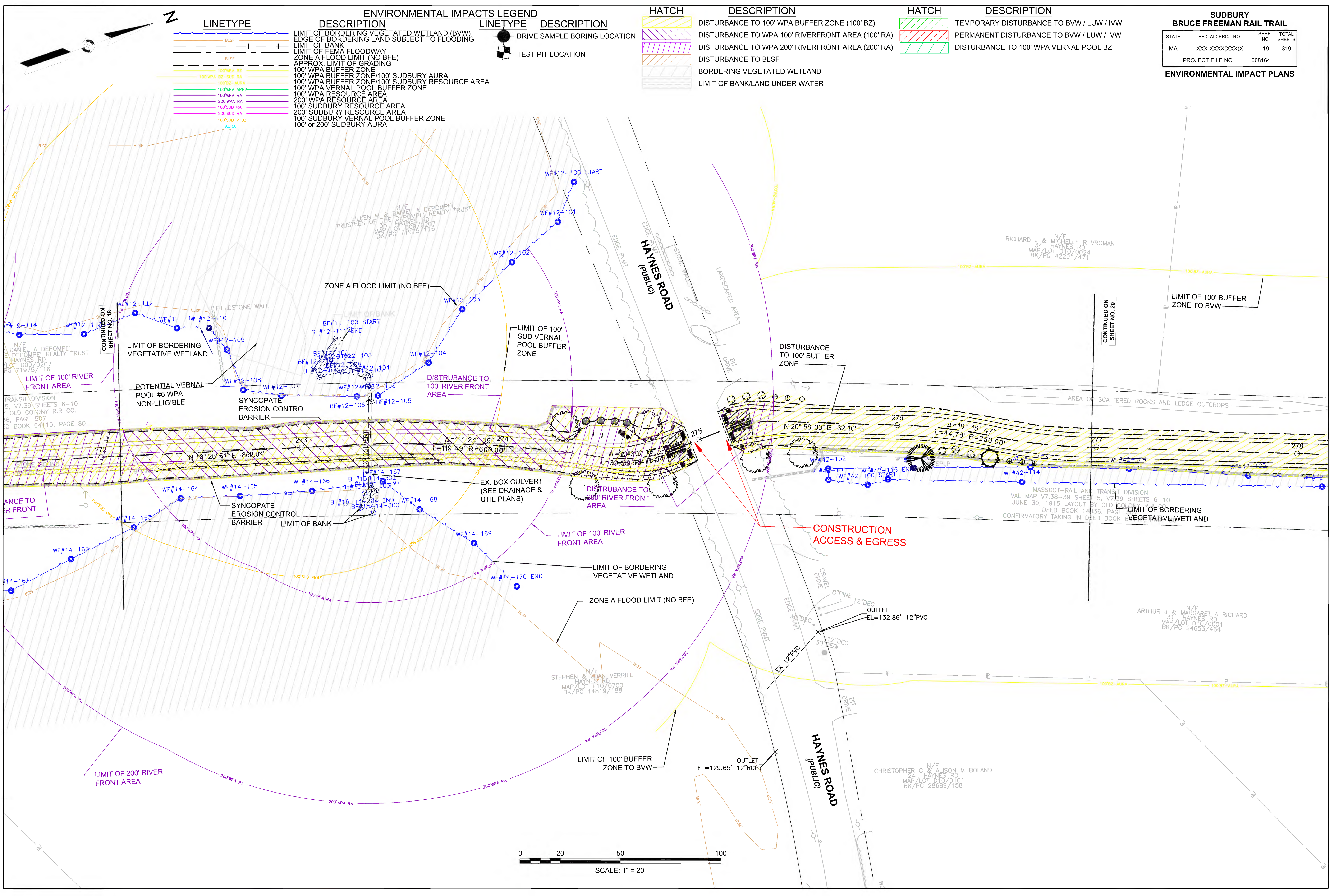

ENVIRONMENTAL IMPACTS LEGEND	
LINETYPE	DESCRIPTION
	LIMIT OF BORDERING VEGETATED WETLAND (BVW)
	EDGE OF BORDERING LAND SUBJECT TO FLOODING
	LIMIT OF BANK
	LIMIT OF FEMA FLOODWAY
	ZONE A FLOOD LIMIT (NO BFE)
	APPROX. LIMIT OF GRADING
	100' WPA BUFFER ZONE
	100' WPA BUFFER ZONE/100' SUDBURY AURA
	100' WPA RA
	100' WPA VERNAL POOL BUFFER ZONE
	100' WPA RESOURCE AREA
	100' SUDBURY RESOURCE AREA
	200' SUDBURY RESOURCE AREA
	100' SUDBURY VERNAL POOL BUFFER ZONE
	100' SUDBURY VERNAL POOL BUFFER ZONE
	AURA

HATCH	DESCRIPTION
	DISTURBANCE TO 100' WPA BUFFER ZONE (100' BZ)
	DISTURBANCE TO WPA 100' RIVERFRONT AREA (100' RA)
	DISTURBANCE TO WPA 200' RIVERFRONT AREA (200' RA)
	DISTURBANCE TO BLSF
	BORDERING VEGETATED WETLAND
	LIMIT OF BANK/LAND UNDER WATER

HATCH	DESCRIPTION
	TEMPORARY DISTURBANCE TO BVW / LUW / IWV
	PERMANENT DISTURBANCE TO BVW / LUW / IWV
	DISTURBANCE TO 100' WPA VERNAL POOL BZ

SUDBURY BRUCE FREEMAN RAIL TRAIL			
STATE	FED. AID PROJ. NO.	SHEET NO.	TOTAL SHEETS
MA	XXX-XXXX(XXX)X	20	319
PROJECT FILE NO.		608164	

ENVIRONMENTAL IMPACT PLANS

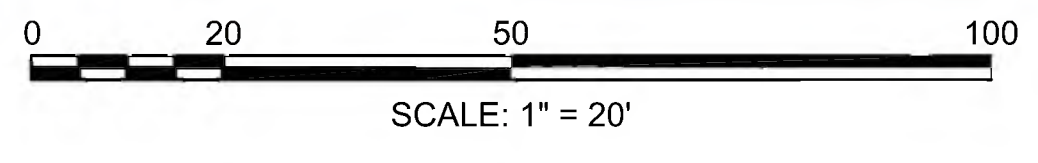
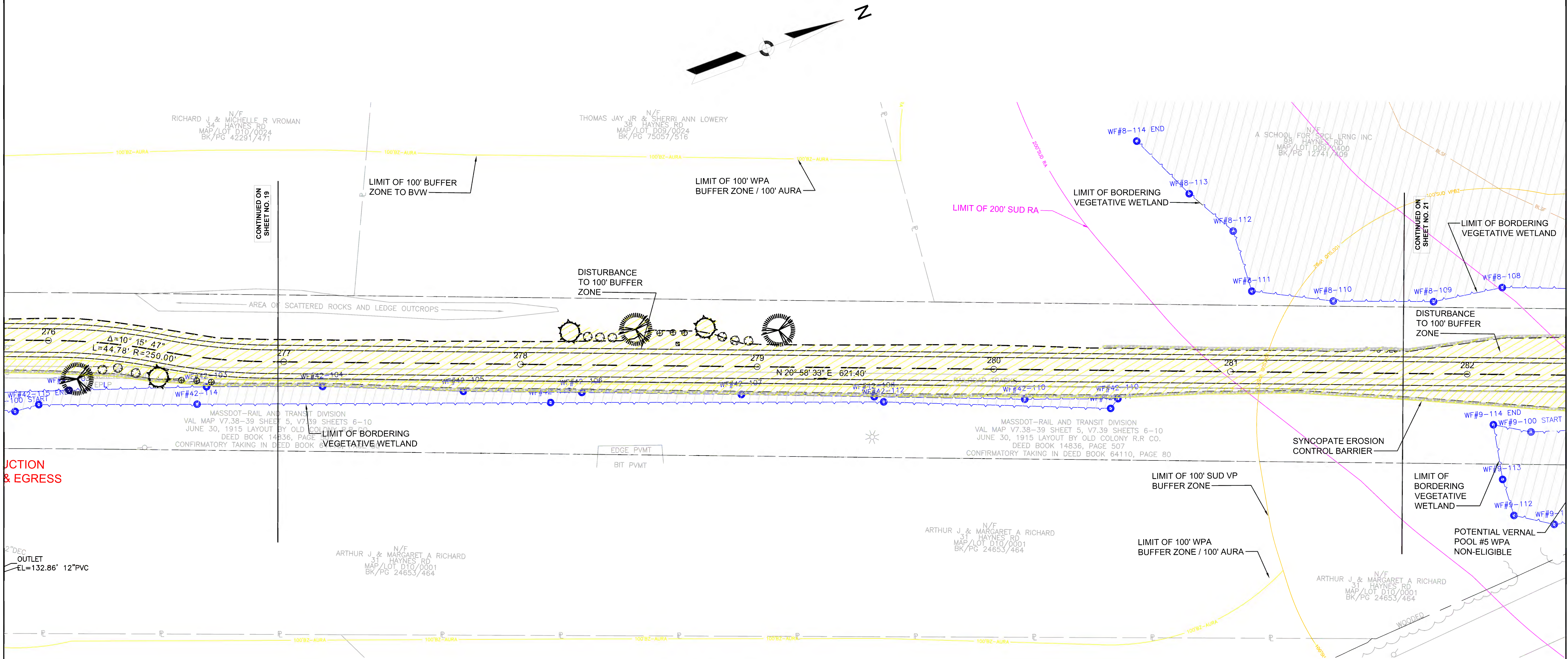

CONTINUED ON SHEET NO. 19

CONTINUED ON SHEET NO. 21

OUTLET & EGRESS

2" DEG
OUTLET
EL=132.86' 12" PVC

LINETYPE	DESCRIPTION	LINETYPE	DESCRIPTION
(Symbol)	LIMIT OF BORDERING VEGETATED WETLAND (BVW)	(Symbol)	DRIVE SAMPLE BORING LOCATION
(Symbol)	EDGE OF BORDERING LAND SUBJECT TO FLOODING	(Symbol)	TEST PIT LOCATION
(Symbol)	LIMIT OF BANK		
(Symbol)	LIMIT OF FEMA FLOODWAY		
(Symbol)	ZONE A FLOOD LIMIT (NO BFE)		
(Symbol)	APPROX. LIMIT OF GRADING		
(Symbol)	100' WPA BUFFER ZONE		
(Symbol)	100' WPA BUFFER ZONE/100' SUDBURY AURA		
(Symbol)	100' WPA BUFFER ZONE/100' SUDBURY RESOURCE AREA		
(Symbol)	100' WPA VERNAL POOL BUFFER ZONE		
(Symbol)	100' WPA RESOURCE AREA		
(Symbol)	200' WPA RESOURCE AREA		
(Symbol)	100' SUDBURY RESOURCE AREA		
(Symbol)	200' SUDBURY RESOURCE AREA		
(Symbol)	100' SUDBURY VERNAL POOL BUFFER ZONE		
(Symbol)	100' or 200' SUDBURY AURA		

HATCH	DESCRIPTION
(Hatch)	DISTURBANCE TO 100' WPA BUFFER ZONE (100' BZ)
(Hatch)	DISTURBANCE TO WPA 100' RIVERFRONT AREA (100' RA)
(Hatch)	DISTURBANCE TO WPA 200' RIVERFRONT AREA (200' RA)
(Hatch)	DISTURBANCE TO BLSF
(Hatch)	BORDERING VEGETATED WETLAND
(Hatch)	LIMIT OF BANK/LAND UNDER WATER

HATCH	DESCRIPTION
(Hatch)	TEMPORARY DISTURBANCE TO BVW / LUW / IWV
(Hatch)	PERMANENT DISTURBANCE TO BVW / LUW / IWV
(Hatch)	DISTURBANCE TO 100' WPA VERNAL POOL BZ

BRUCE FREEMAN RAIL TRAIL			
STATE	FED. AID PROJ. NO.	SHEET NO.	TOTAL SHEETS
MA	XXX-XXXX(XXX)X	21	319
PROJECT FILE NO.		608164	

ENVIRONMENTAL IMPACT PLANS

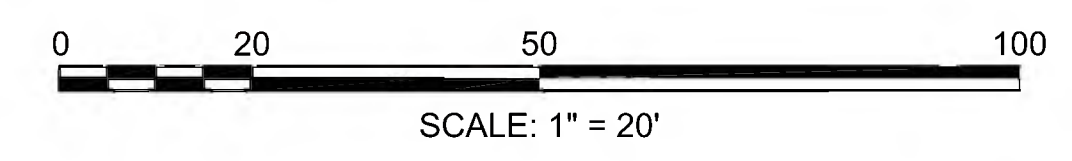
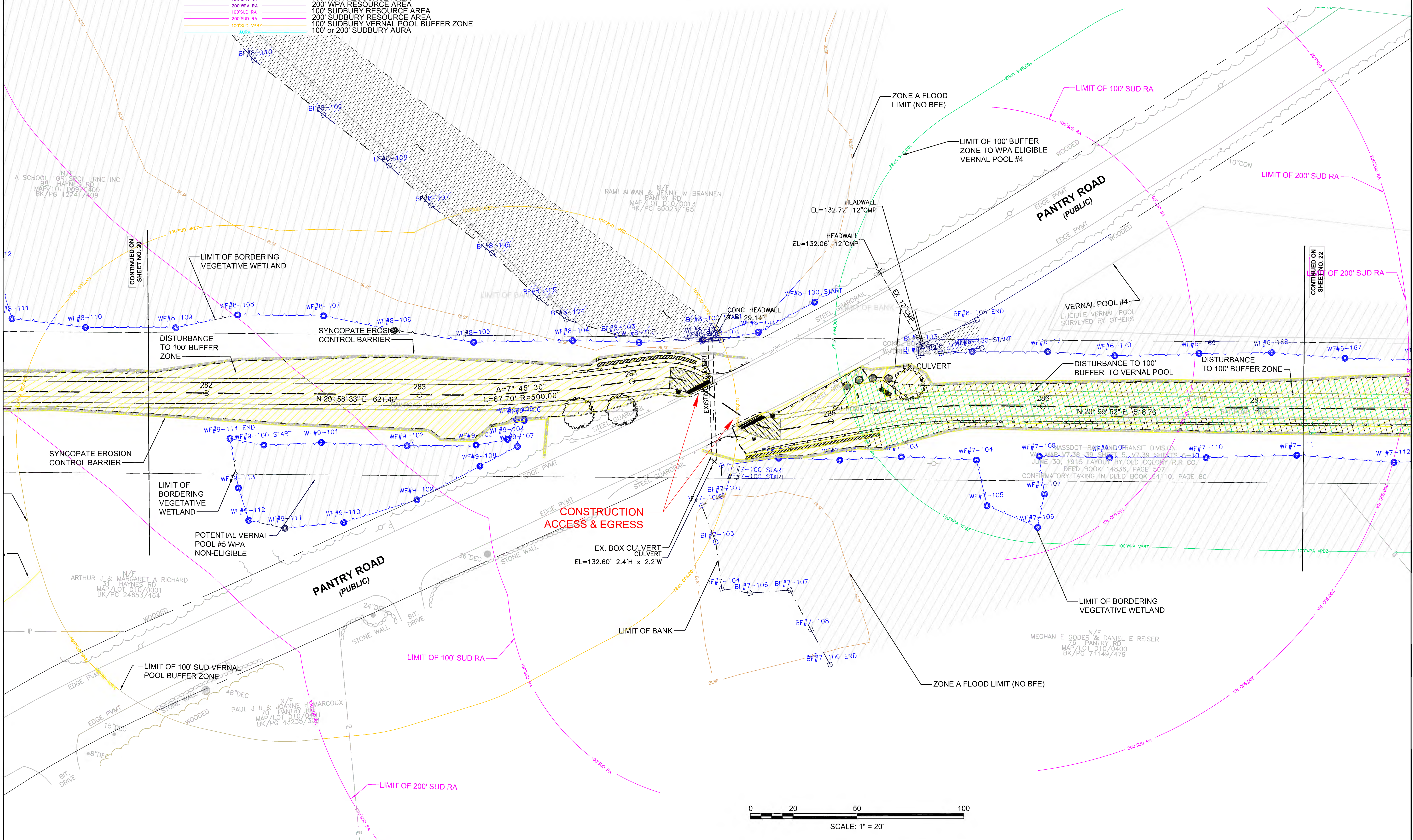

608164_NOI(GENERAL PLANS).DWG Plotted on 18-Feb-2022 5:00 PM

SUDBURY BRUCE FREEMAN RAIL TRAIL			
STATE	FED. AID PROJ. NO.	SHEET NO.	TOTAL SHEETS
MA	XXX-XXX(XXX)X	22	319
PROJECT FILE NO.		608164	

ENVIRONMENTAL IMPACT PLANS

LINETYPE	DESCRIPTION	LINETYPE	DESCRIPTION	HATCH	DESCRIPTION	HATCH	DESCRIPTION
(Symbol)	LIMIT OF BORDERING VEGETATED WETLAND (BVW)	(Symbol)	DRIVE SAMPLE BORING LOCATION	(Symbol)	DISTURBANCE TO 100' WPA BUFFER ZONE (100' BZ)	(Symbol)	TEMPORARY DISTURBANCE TO BVW / LUW / IVW
(Symbol)	EDGE OF BORDERING LAND SUBJECT TO FLOODING	(Symbol)	TEST PIT LOCATION	(Symbol)	DISTURBANCE TO WPA 100' RIVERFRONT AREA (100' RA)	(Symbol)	PERMANENT DISTURBANCE TO BVW / LUW / IVW
(Symbol)	LIMIT OF FEMA FLOODWAY ZONE A FLOOD LIMIT (NO BFE)			(Symbol)	DISTURBANCE TO WPA 200' RIVERFRONT AREA (200' RA)	(Symbol)	DISTURBANCE TO 100' WPA VERNAL POOL BZ
(Symbol)	APPROX. LIMIT OF GRADING			(Symbol)	DISTURBANCE TO BLSF		
(Symbol)	100' WPA BUFFER ZONE			(Symbol)	BORDERING VEGETATED WETLAND		
(Symbol)	100' WPA BUFFER ZONE/100' SUDBURY AURA			(Symbol)	LIMIT OF BANK/LAND UNDER WATER		
(Symbol)	100' WPA BUFFER ZONE/100' SUDBURY RESOURCE AREA						
(Symbol)	100' WPA VERNAL POOL BUFFER ZONE						
(Symbol)	100' WPA RESOURCE AREA						
(Symbol)	200' WPA RESOURCE AREA						
(Symbol)	100' SUDBURY RESOURCE AREA						
(Symbol)	200' SUDBURY RESOURCE AREA						
(Symbol)	100' SUDBURY VERNAL POOL BUFFER ZONE						
(Symbol)	100' SUDBURY AURA						

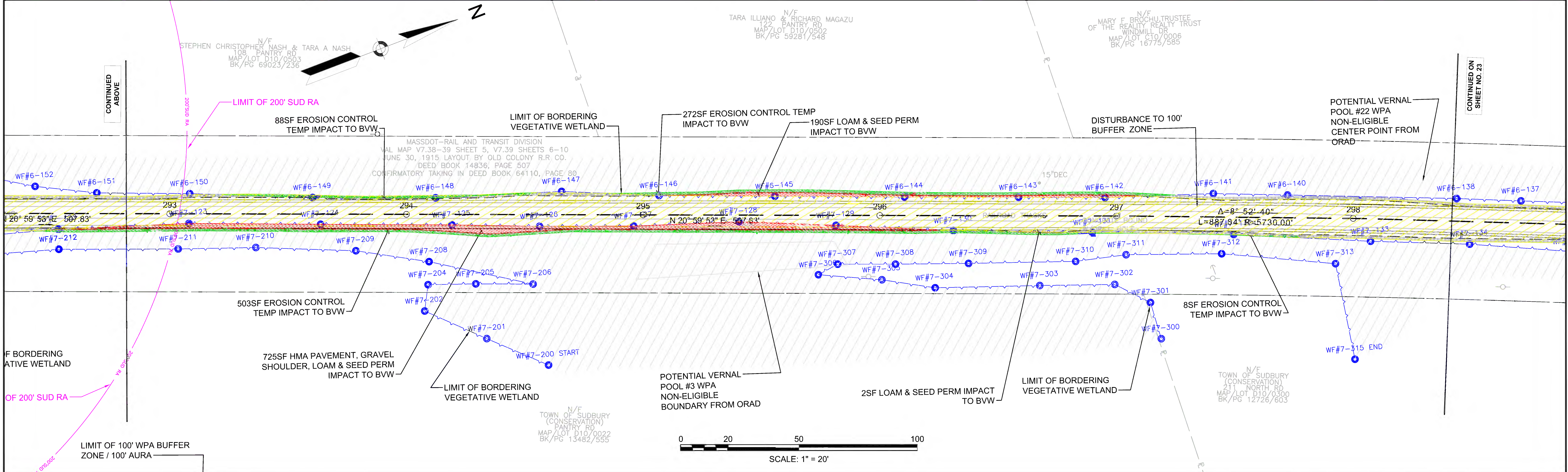
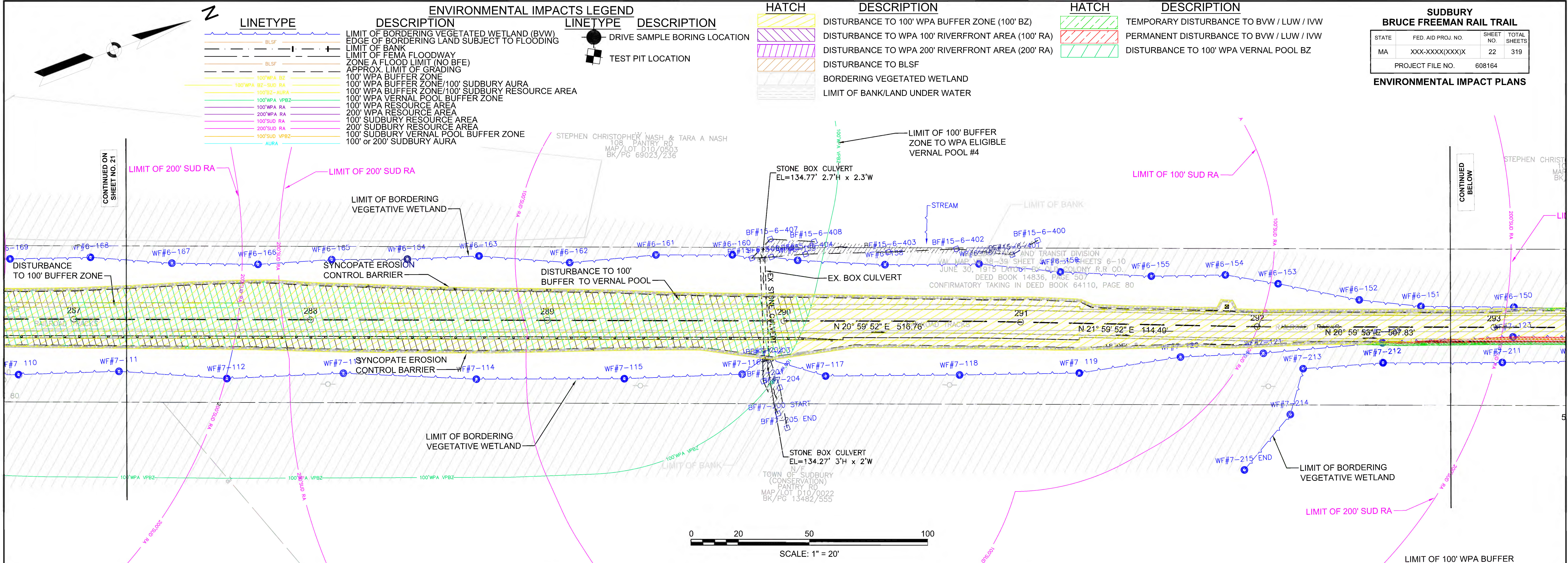

LINETYPE	DESCRIPTION	LINETYPE	DESCRIPTION
(Symbol)	LIMIT OF BORDERING VEGETATED WETLAND (BVW)	(Symbol)	DRIVE SAMPLE BORING LOCATION
(Symbol)	EDGE OF BORDERING LAND SUBJECT TO FLOODING	(Symbol)	TEST PIT LOCATION
(Symbol)	LIMIT OF BANK		
(Symbol)	LIMIT OF FEMA FLOODWAY ZONE A FLOOD LIMIT (NO BFE)		
(Symbol)	APPROX. LIMIT OF GRADING		
(Symbol)	100' WPA BUFFER ZONE		
(Symbol)	100' WPA BUFFER ZONE/100' SUDBURY AURA		
(Symbol)	100' WPA BUFFER ZONE/100' SUDBURY RESOURCE AREA		
(Symbol)	100' WPA VERNAL POOL BUFFER ZONE		
(Symbol)	100' WPA RESOURCE AREA		
(Symbol)	200' WPA RESOURCE AREA		
(Symbol)	100' SUDBURY RESOURCE AREA		
(Symbol)	200' SUDBURY RESOURCE AREA		
(Symbol)	100' SUDBURY VERNAL POOL BUFFER ZONE		
(Symbol)	100' SUDBURY AURA		

HATCH	DESCRIPTION
(Hatch)	DISTURBANCE TO 100' WPA BUFFER ZONE (100' BZ)
(Hatch)	DISTURBANCE TO WPA 100' RIVERFRONT AREA (100' RA)
(Hatch)	DISTURBANCE TO WPA 200' RIVERFRONT AREA (200' RA)
(Hatch)	DISTURBANCE TO BLSF
(Hatch)	BORDERING VEGETATED WETLAND
(Hatch)	LIMIT OF BANK/LAND UNDER WATER

HATCH	DESCRIPTION
(Hatch)	TEMPORARY DISTURBANCE TO BVW / LUW / IWV
(Hatch)	PERMANENT DISTURBANCE TO BVW / LUW / IWV
(Hatch)	DISTURBANCE TO 100' WPA VERNAL POOL BZ

BRUCE FREEMAN RAIL TRAIL			
STATE	FED. AID PROJ. NO.	SHEET NO.	TOTAL SHEETS
MA	XXX-XXXX(XXX)X	23	319
PROJECT FILE NO.		608164	

ENVIRONMENTAL IMPACT PLANS

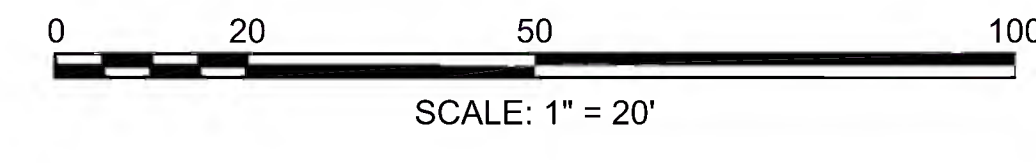
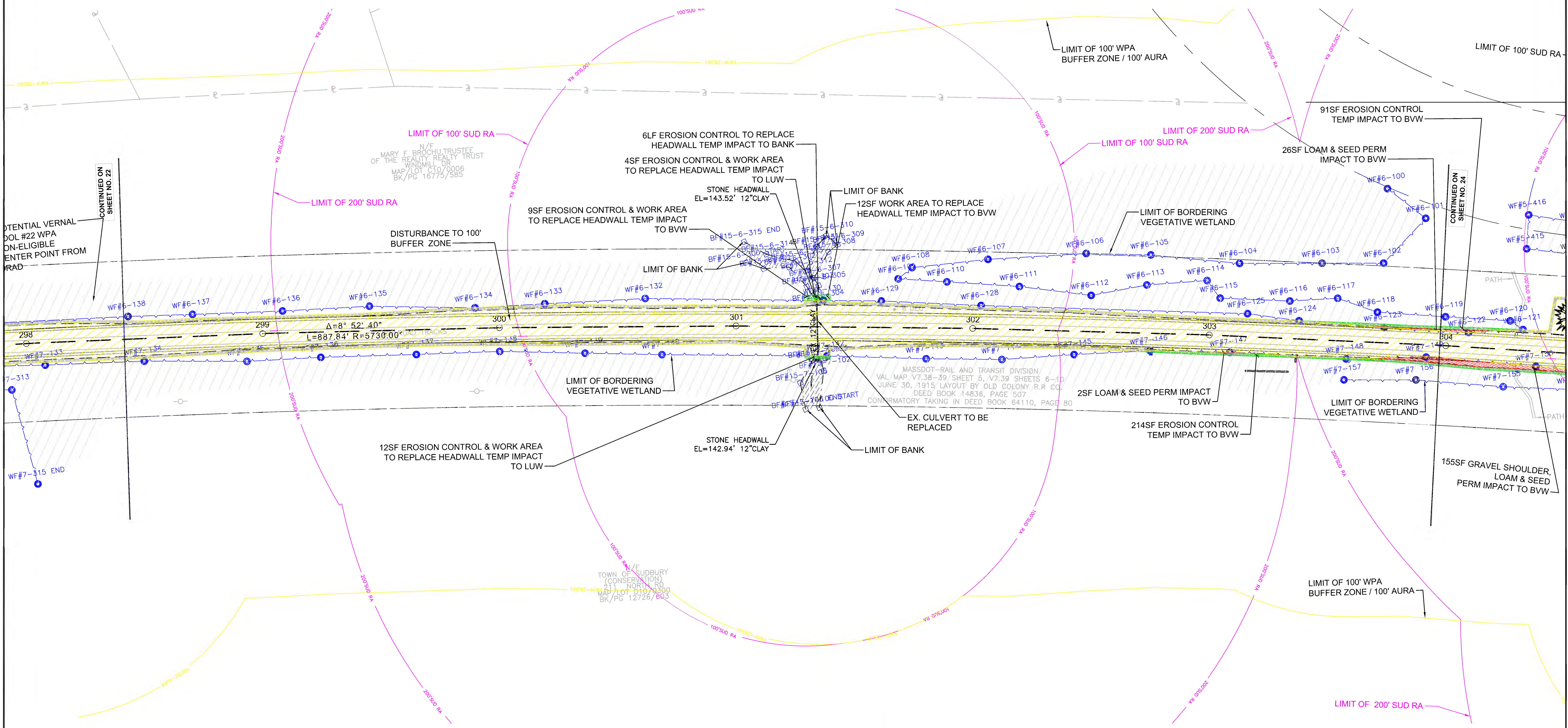

POTENTIAL VERNAL POOL #22 WPA NON-ELIGIBLE CENTER POINT FROM ROAD

CONTINUED ON SHEET NO. 22

CONTINUED ON SHEET NO. 24

MARY F BROCHU TRUSTEE OF THE REALTY TRUST WINDMILL DR MAP LOT 610 0006 BK/PG 16775/585

MASSDOT-RAIL AND TRANSIT DIVISION VAL MAP V7.38-39 SHEET 5, V7.39 SHEETS 6-10 JUNE 30, 1915 LAYOUT BY OLD COLONY R.R CO. DEED BOOK 14836, PAGE 507 CONSERVATORY TAKING IN DEED BOOK 64110, PAGE 80

TOWN OF SUDBURY (CONSERVATION) 211 NORTH RD MAP LOT D16 0300 BK/PG 12726/603

ENVIRONMENTAL IMPACTS LEGEND	
LINETYPE	DESCRIPTION
	LIMIT OF BORDERING VEGETATED WETLAND (BVW)
	EDGE OF BORDERING LAND SUBJECT TO FLOODING
	LIMIT OF BANK
	LIMIT OF FEMA FLOODWAY ZONE A FLOOD LIMIT (NO BFE)
	APPROX. LIMIT OF GRADING
	100' WPA BUFFER ZONE
	100' WPA BUFFER ZONE/100' SUDBURY AURA
	100' WPA BUFFER ZONE/100' SUDBURY RESOURCE AREA
	100' WPA VERNAL POOL BUFFER ZONE
	100' WPA RESOURCE AREA
	200' WPA RESOURCE AREA
	100' SUDBURY RESOURCE AREA
	200' SUDBURY RESOURCE AREA
	100' SUDBURY VERNAL POOL BUFFER ZONE
	100' SUDBURY AURA

HATCH	DESCRIPTION
	DISTURBANCE TO 100' WPA BUFFER ZONE (100' BZ)
	DISTURBANCE TO WPA 100' RIVERFRONT AREA (100' RA)
	DISTURBANCE TO WPA 200' RIVERFRONT AREA (200' RA)
	DISTURBANCE TO BLSF
	BORDERING VEGETATED WETLAND
	LIMIT OF BANK/LAND UNDER WATER

HATCH	DESCRIPTION
	TEMPORARY DISTURBANCE TO BVW / LUW / IWV
	PERMANENT DISTURBANCE TO BVW / LUW / IWV
	DISTURBANCE TO 100' WPA VERNAL POOL BZ

SUDBURY BRUCE FREEMAN RAIL TRAIL			
STATE	FED. AID PROJ. NO.	SHEET NO.	TOTAL SHEETS
MA	XXX-XXXX(XXX)X	24	319
PROJECT FILE NO.		608164	

ENVIRONMENTAL IMPACT PLANS

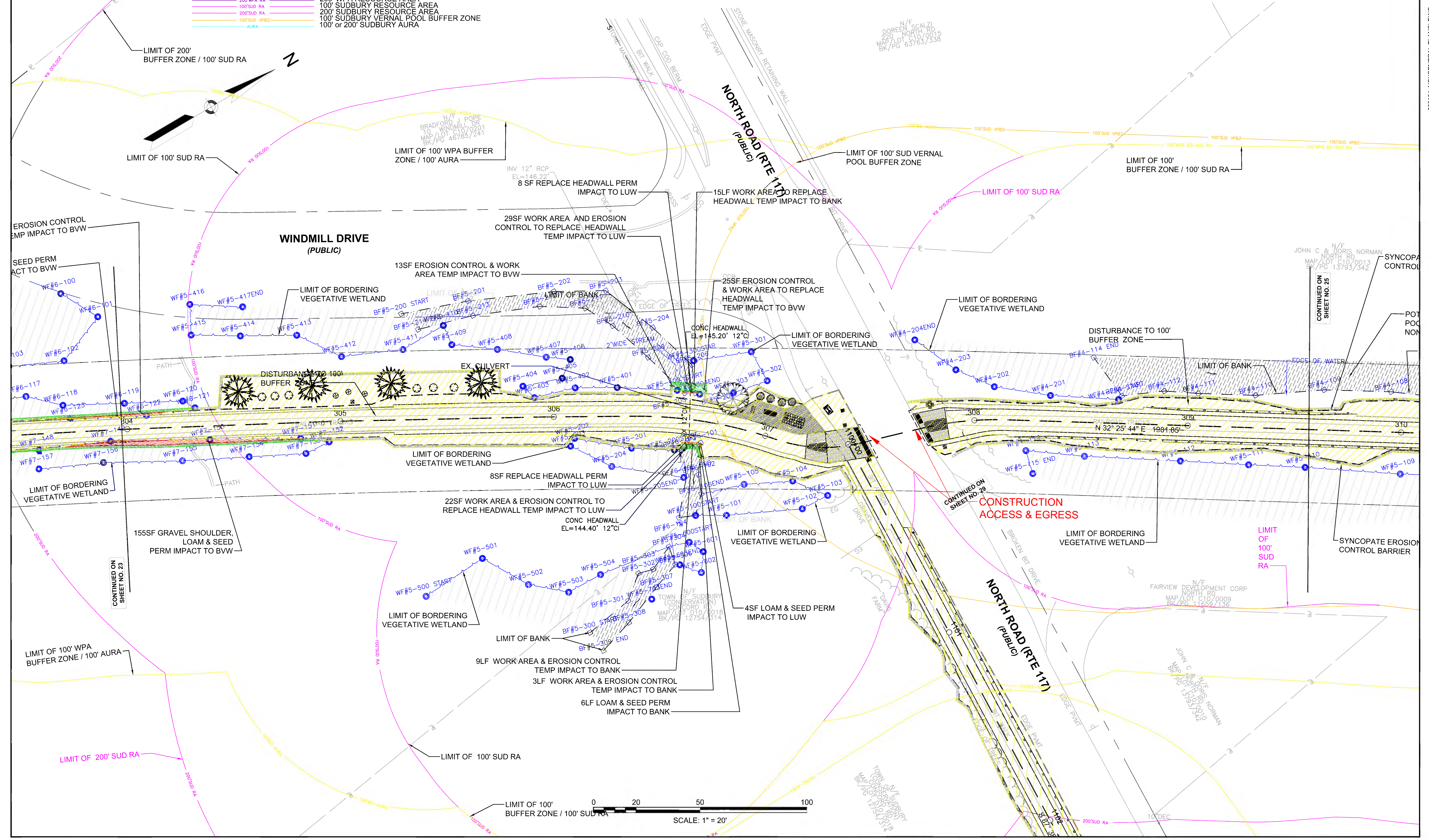

CONTINUED ON SHEET NO. 23

CONTINUED ON SHEET NO. 29

CONTINUED ON SHEET NO. 25

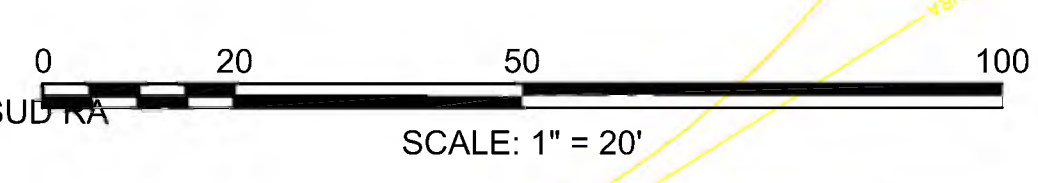

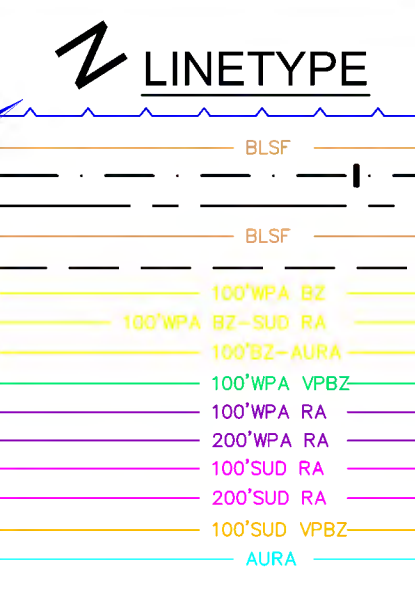

ENVIRONMENTAL IMPACTS LEGEND

LINETYPE	DESCRIPTION	LINETYPE	DESCRIPTION
---	LIMIT OF BORDERING VEGETATED WETLAND (BVW)	●	DRIVE SAMPLE BORING LOCATION
---	EDGE OF BORDERING LAND SUBJECT TO FLOODING	■	TEST PIT LOCATION
---	LIMIT OF BANK		
---	LIMIT OF FEMA FLOODWAY ZONE A FLOOD LIMIT (NO BFE)		
---	APPROX. LIMIT OF GRADING		
---	100' WPA BUFFER ZONE		
---	100' WPA BUFFER ZONE/100' SUDBURY AURA		
---	100' WPA BUFFER ZONE/100' SUDBURY RESOURCE AREA		
---	100' WPA VERNAL POOL BUFFER ZONE		
---	100' WPA RESOURCE AREA		
---	200' WPA RESOURCE AREA		
---	100' SUDBURY RESOURCE AREA		
---	200' SUDBURY RESOURCE AREA		
---	100' SUDBURY VERNAL POOL BUFFER ZONE		
---	100' or 200' SUDBURY AURA		

HATCH

HATCH	DESCRIPTION
[Hatched pattern]	DISTURBANCE TO 100' WPA BUFFER ZONE (100' BZ)
[Hatched pattern]	DISTURBANCE TO WPA 100' RIVERFRONT AREA (100' RA)
[Hatched pattern]	DISTURBANCE TO WPA 200' RIVERFRONT AREA (200' RA)
[Hatched pattern]	DISTURBANCE TO BLSF
[Hatched pattern]	BORDERING VEGETATED WETLAND
[Hatched pattern]	LIMIT OF BANK/LAND UNDER WATER

HATCH

HATCH	DESCRIPTION
[Hatched pattern]	TEMPORARY DISTURBANCE TO BVW / LUW / IVW
[Hatched pattern]	PERMANENT DISTURBANCE TO BVW / LUW / IVW
[Hatched pattern]	DISTURBANCE TO 100' WPA VERNAL POOL BZ

SUDBURY BRUCE FREEMAN RAIL TRAIL

STATE	FED. AID PROJ. NO.	SHEET NO.	TOTAL SHEETS
MA	XXX-XXXX(XXX)X	26	319

PROJECT FILE NO. 608164

ENVIRONMENTAL IMPACT PLANS

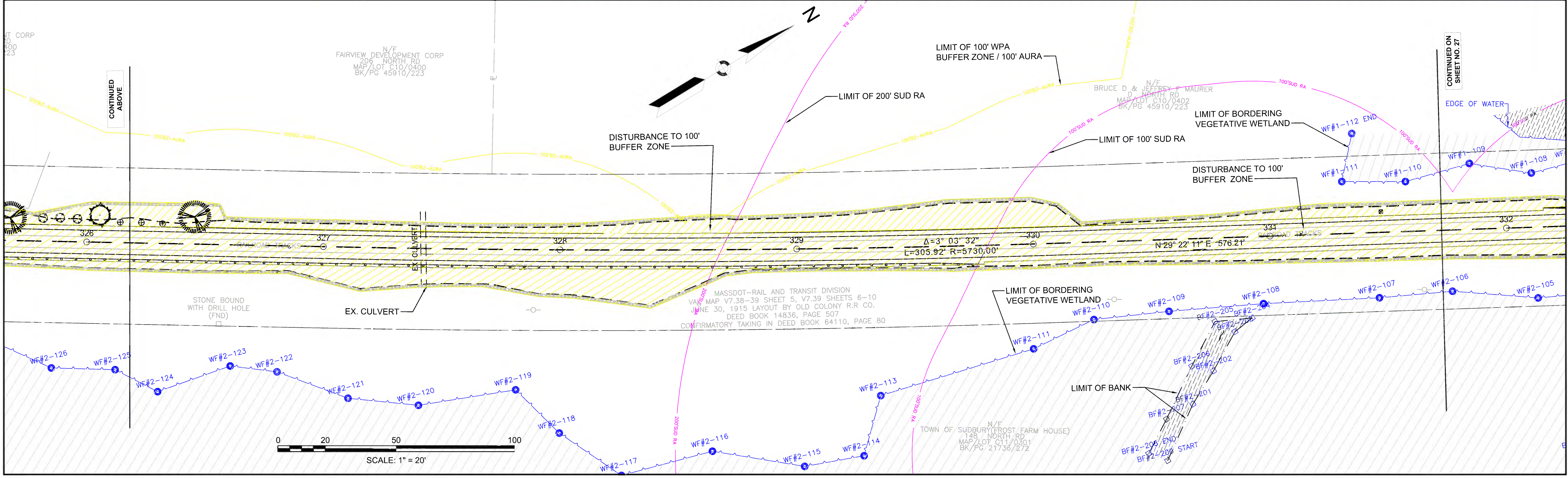
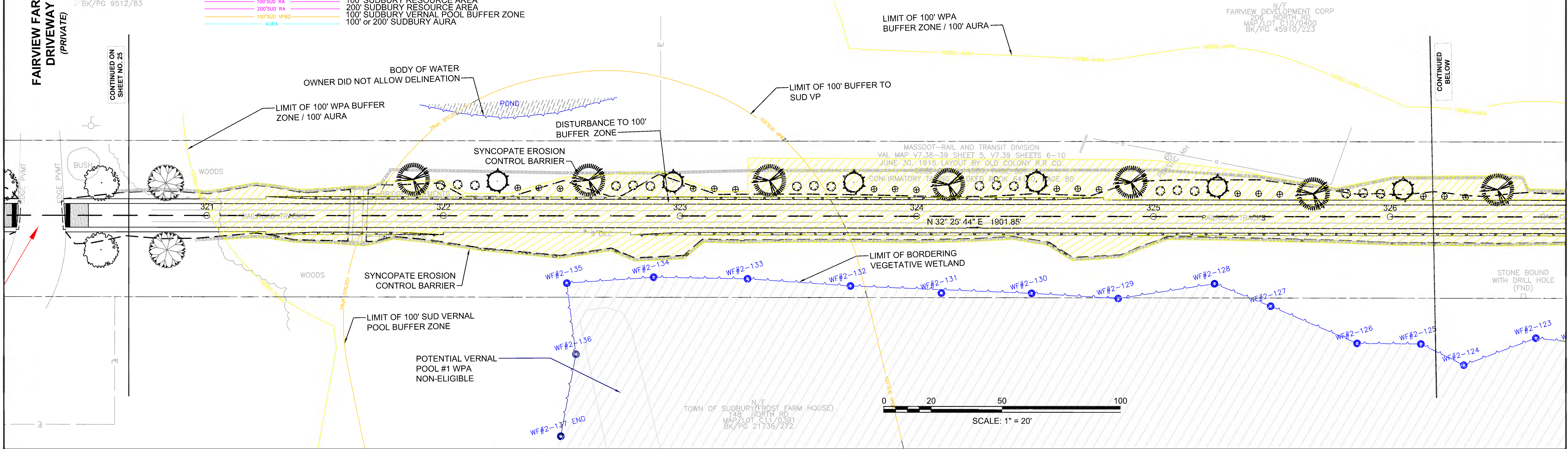

ENVIRONMENTAL IMPACTS LEGEND	
LINETYPE	DESCRIPTION
	LIMIT OF BORDERING VEGETATED WETLAND (BVW)
	EDGE OF BORDERING LAND SUBJECT TO FLOODING
	LIMIT OF BANK
	LIMIT OF FEMA FLOODWAY
	ZONE A FLOOD LIMIT (NO BFE)
	APPROX. LIMIT OF GRADING
	100' WPA BUFFER ZONE
	100' WPA BUFFER ZONE/100' SUDBURY AURA
	100' WPA BUFFER ZONE/100' SUDBURY RESOURCE AREA
	100' WPA VERNAL POOL BUFFER ZONE
	100' WPA RESOURCE AREA
	200' WPA RESOURCE AREA
	100' SUDBURY RESOURCE AREA
	200' SUDBURY RESOURCE AREA
	100' SUDBURY VERNAL POOL BUFFER ZONE
	100' SUDBURY AURA

LINETYPE	DESCRIPTION
	DRIVE SAMPLE BORING LOCATION
	TEST PIT LOCATION

HATCH	DESCRIPTION
	DISTURBANCE TO 100' WPA BUFFER ZONE (100' BZ)
	DISTURBANCE TO WPA 100' RIVERFRONT AREA (100' RA)
	DISTURBANCE TO WPA 200' RIVERFRONT AREA (200' RA)
	DISTURBANCE TO BLSF
	BORDERING VEGETATED WETLAND
	LIMIT OF BANK/LAND UNDER WATER

HATCH	DESCRIPTION
	TEMPORARY DISTURBANCE TO BVW / LUW / IVW
	PERMANENT DISTURBANCE TO BVW / LUW / IVW
	DISTURBANCE TO 100' WPA VERNAL POOL BZ

SUDBURY BRUCE FREEMAN RAIL TRAIL			
STATE	FED. AID PROJ. NO.	SHEET NO.	TOTAL SHEETS
MA	XXX-XXXX(XXX)X	27	319
PROJECT FILE NO. 608164			

ENVIRONMENTAL IMPACT PLANS

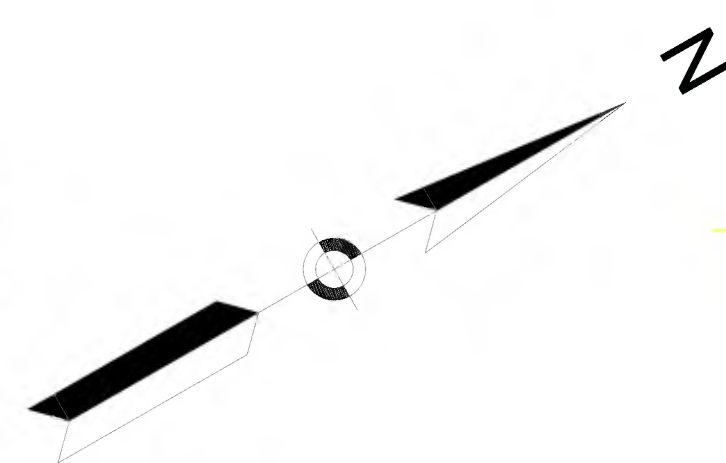
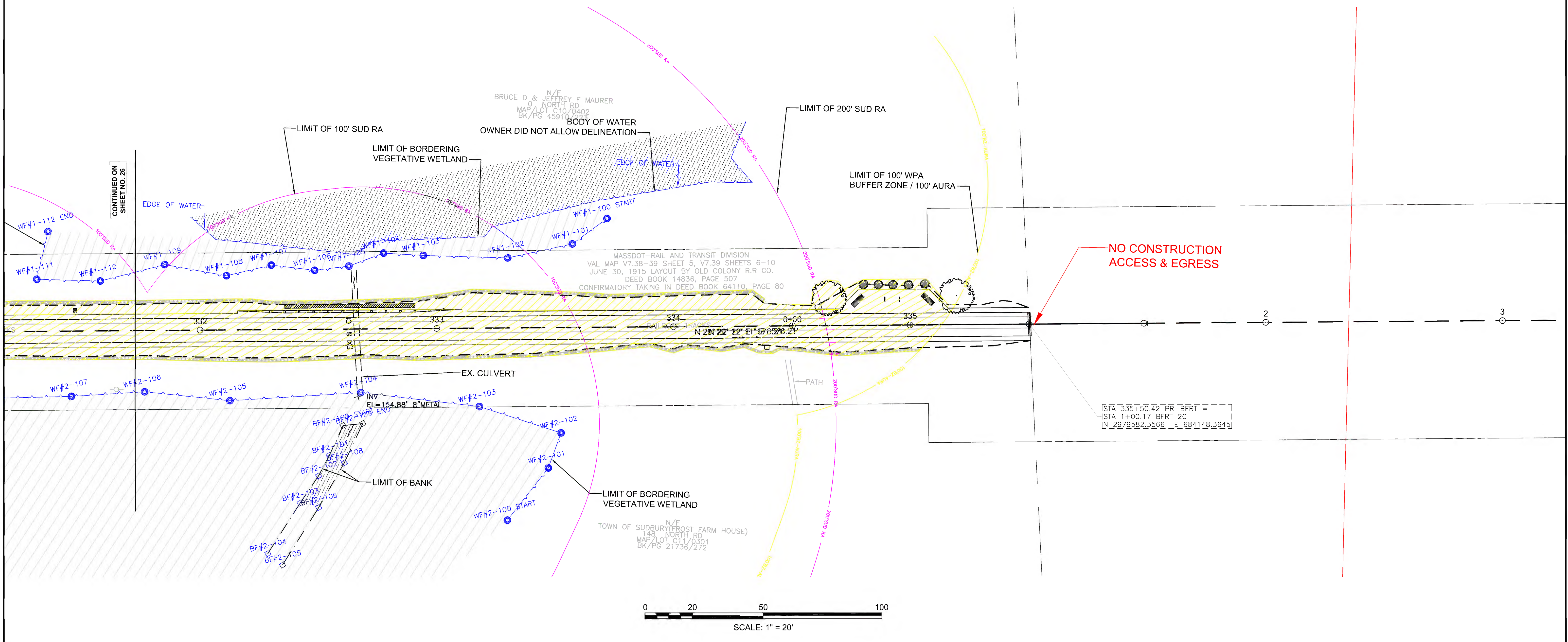

CONTINUED ON
SHEET NO. 26

ENVIRONMENTAL IMPACTS LEGEND	
LINETYPE	DESCRIPTION
	LIMIT OF BORDERING VEGETATED WETLAND (BVW)
	EDGE OF BORDERING LAND SUBJECT TO FLOODING
	LIMIT OF BANK
	LIMIT OF FEMA FLOODWAY
	ZONE A FLOOD LIMIT (NO BFE)
	APPROX. LIMIT OF GRADING
	100' WPA BUFFER ZONE
	100' WPA BUFFER ZONE/100' SUDBURY AURA
	100' WPA BUFFER ZONE/100' SUDBURY RESOURCE AREA
	100' WPA VERNAL POOL BUFFER ZONE
	100' WPA RESOURCE AREA
	200' WPA RESOURCE AREA
	100' SUDBURY RESOURCE AREA
	200' SUDBURY RESOURCE AREA
	100' SUDBURY VERNAL POOL BUFFER ZONE
	100' or 200' SUDBURY AURA

HATCH	DESCRIPTION
	DISTURBANCE TO 100' WPA BUFFER ZONE (100' BZ)
	DISTURBANCE TO WPA 100' RIVERFRONT AREA (100' RA)
	DISTURBANCE TO WPA 200' RIVERFRONT AREA (200' RA)
	DISTURBANCE TO BLSF
	BORDERING VEGETATED WETLAND
	LIMIT OF BANK/LAND UNDER WATER

HATCH	DESCRIPTION
	TEMPORARY DISTURBANCE TO BVW / LUW / IVW
	PERMANENT DISTURBANCE TO BVW / LUW / IVW
	DISTURBANCE TO 100' WPA VERNAL POOL BZ

SUBBURY BRUCE FREEMAN RAIL TRAIL			
STATE	FED. AID PROJ. NO.	SHEET NO.	TOTAL SHEETS
MA	XXX-XXXX(XXX)X	28	319
PROJECT FILE NO.		608164	

ENVIRONMENTAL IMPACT PLANS

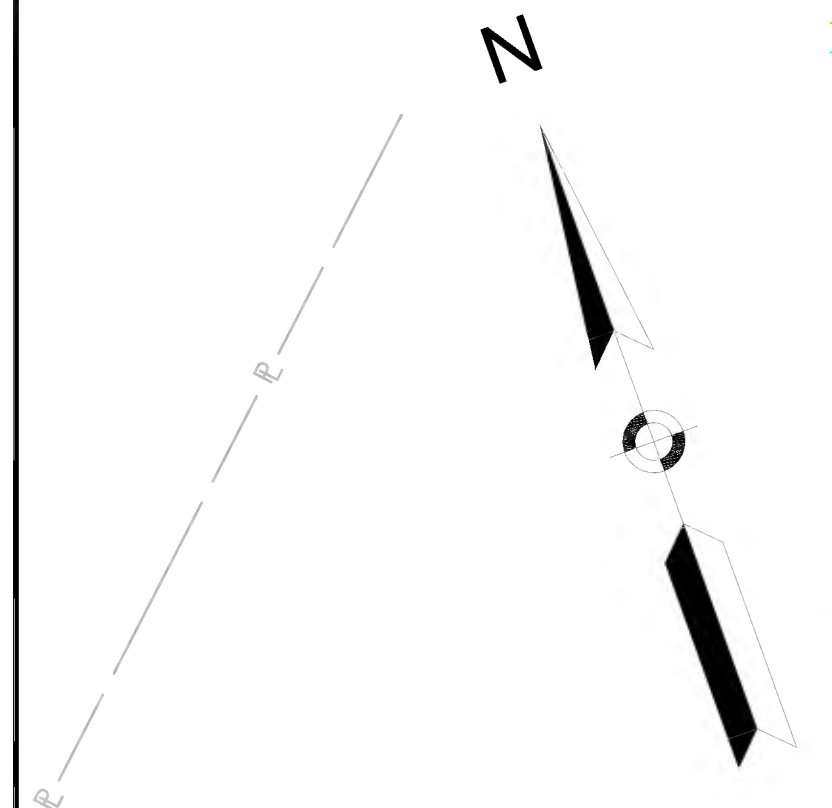

N/F
TOWN OF SUDBURY
0 HUDSON RD
009-0200
BOOK 13189 PAGE 604

N/F
TOWN OF SUDBURY (TREASURER)
0 HUDSON RD
MAP/LOT 009/0200
BK/PG 13189/604

N/F
LAWRENCE W TIGHE, TRUSTEE OF THE HUDSON RD TRUST #1
38 HUDSON RD
MAP/LOT 009/0002
BK/PG 30663/361

PARKINSON'S LOT

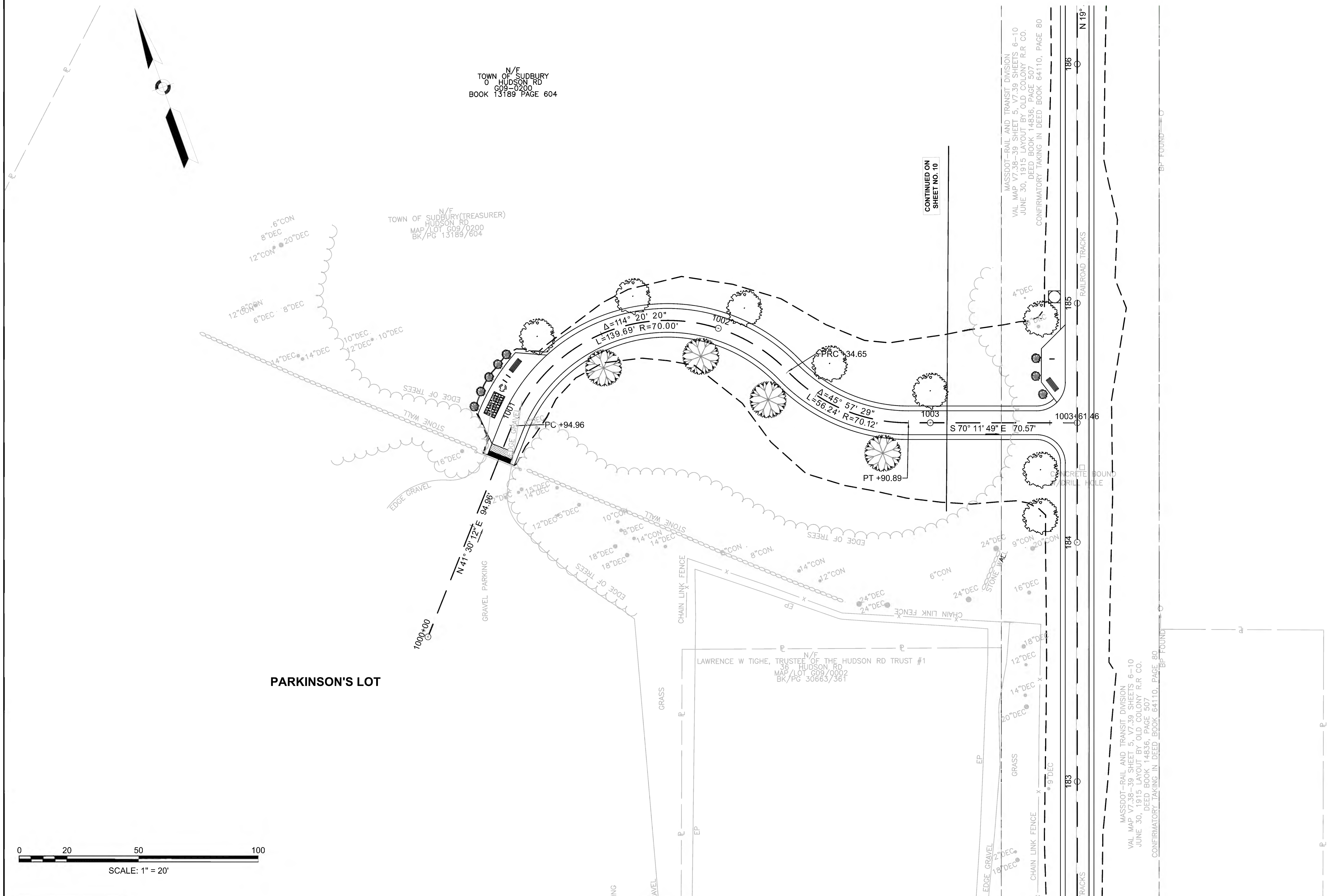
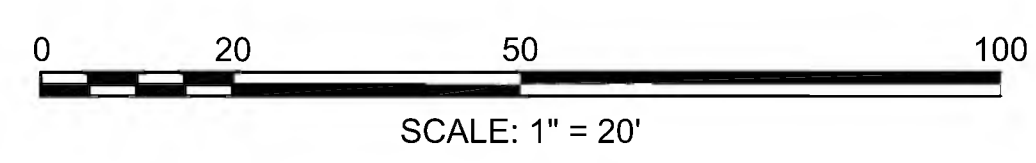

MASSDOT-RAIL AND TRANSIT DIVISION
VAL MAP V7.38-39, SHEET 5, V7.39, SHEETS 6-10
JUNE 30, 1915 LAYOUT BY OLD COLONY R.R. CO.
DEED BOOK 14836, PAGE 507
CONFIRMATORY TAKING IN DEED BOOK 64110, PAGE 80

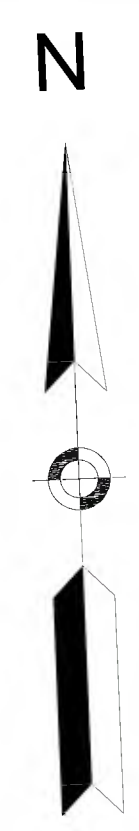

LINETYPE	DESCRIPTION
	LIMIT OF BORDERING VEGETATED WETLAND (BVW)
	EDGE OF BORDERING LAND SUBJECT TO FLOODING
	LIMIT OF BANK
	LIMIT OF FEMA FLOODWAY
	ZONE A FLOOD LIMIT (NO BFE)
	APPROX. LIMIT OF GRADING
	100' WPA BUFFER ZONE
	100' WPA BUFFER ZONE/100' SUDBURY AURA
	100' WPA BUFFER ZONE/100' SUDBURY RESOURCE AREA
	100' WPA VERNAL POOL BUFFER ZONE
	100' WPA RESOURCE AREA
	200' WPA RESOURCE AREA
	100' SUDBURY RESOURCE AREA
	200' SUDBURY RESOURCE AREA
	100' SUDBURY VERNAL POOL BUFFER ZONE
	100' or 200' SUDBURY AURA

LINETYPE	DESCRIPTION
	DRIVE SAMPLE BORING LOCATION
	TEST PIT LOCATION

HATCH	DESCRIPTION
	DISTURBANCE TO 100' WPA BUFFER ZONE (100' BZ)
	DISTURBANCE TO WPA 100' RIVERFRONT AREA (100' RA)
	DISTURBANCE TO WPA 200' RIVERFRONT AREA (200' RA)
	DISTURBANCE TO BLSF
	BORDERING VEGETATED WETLAND
	LIMIT OF BANK/LAND UNDER WATER

HATCH	DESCRIPTION
	TEMPORARY DISTURBANCE TO BVW / LUW / IVW
	PERMANENT DISTURBANCE TO BVW / LUW / IVW
	DISTURBANCE TO 100' WPA VERNAL POOL BZ

SUDBURY BRUCE FREEMAN RAIL TRAIL			
STATE	FED. AID PROJ. NO.	SHEET NO.	TOTAL SHEETS
MA	XXX-XXXX(XXX)X	29	319
PROJECT FILE NO.		608164	
RESOURCE AREA IMPACTS			

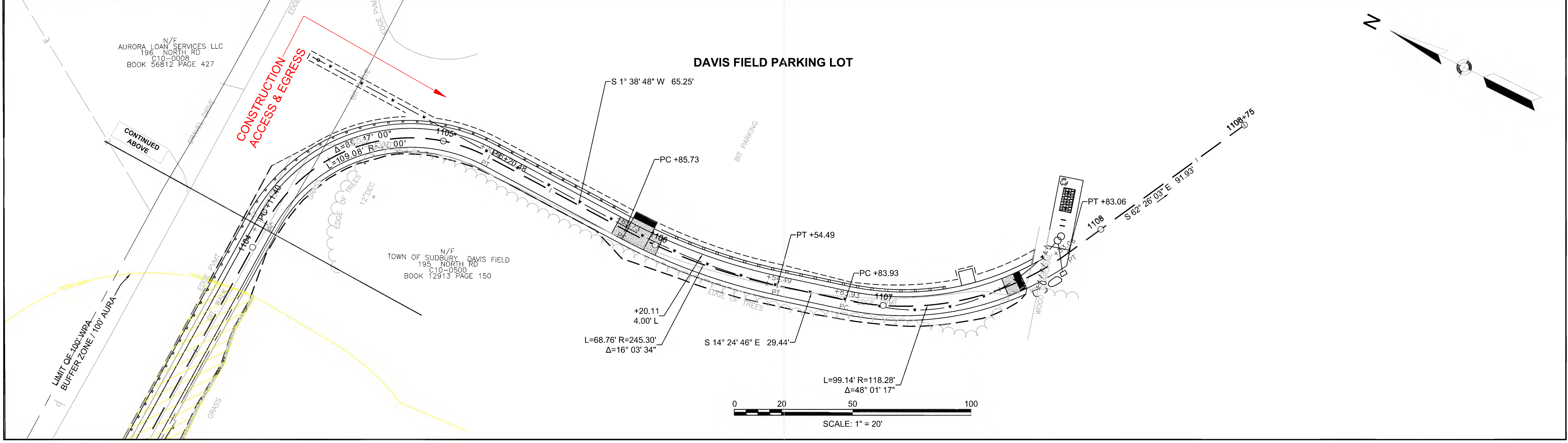
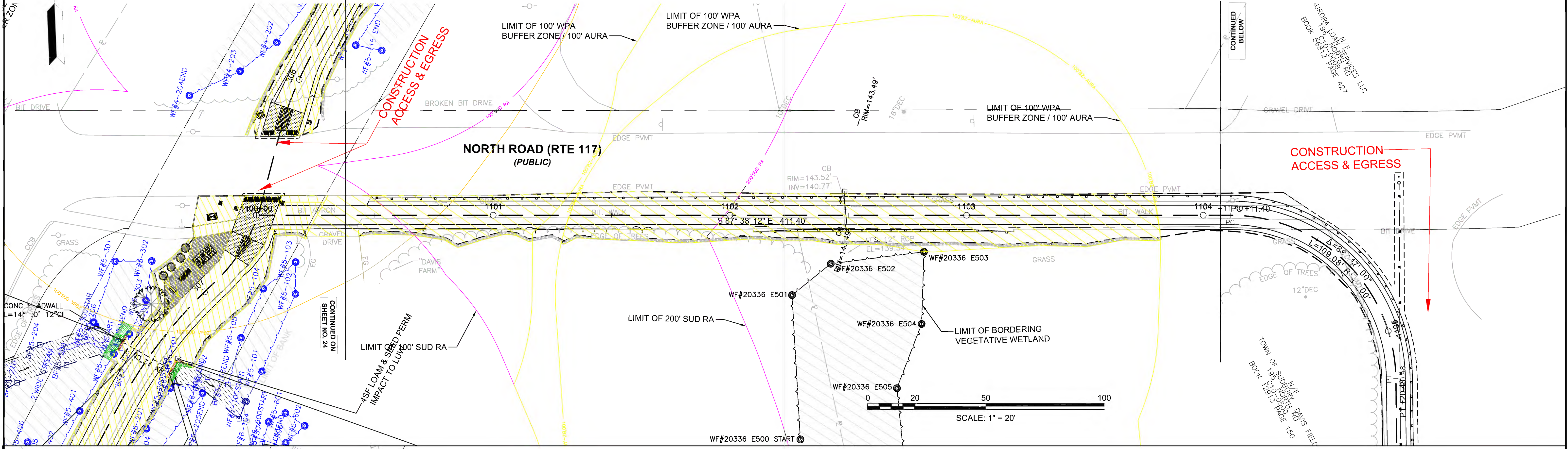

PLANT LIST

KEY	BOTANICAL NAME	COMMON NAME	QTY.	SIZE
VISUAL SCREEN MIX				
JV	JUNIPERUS VIRGINIANA	EASTERN RED CEDAR	5	4-5' HT.
VT	VILBURUM TRILOBUM	HIGHBUSH CRANBERRY	29	3 GAL.
IG	ILEX GLABRA	INKBERRY	25	3 GAL.
PS	PINUS STROBUS	EASTERN WHITE PINE	6	4-5' HT.
AC	ABIES CONCOLOR	WHITE FIR	5	

HIGHWAY GUARD DETAILS

NONE
TRAFFIC SIGNAL CONDUIT
NONE

WATER SUPPLY ALTERATIONS

NONE
DRAINAGE DETAILS
NONE

FENCING DETAILS

TIMBER FENCE (THREE-RAIL) STA. 104+80 LT TO STA. 107+15 LT
TIMBER FENCE (THREE-RAIL) STA. 108+88 RT TO STA. 109+30 RT
TIMBER FENCE (THREE-RAIL) STA. 109+00 LT TO STA. 109+85 LT

LEGEND:

PROPOSED WHEELCHAIR RAMP DETAIL #
PLANT QUANTITY AND SPECIES

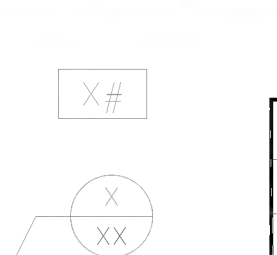

SUDBURY BRUCE FREEMAN RAIL TRAIL

STATE	FED. AID PROJ. NO.	SHEET NO.	TOTAL SHEETS
MA	XXX-XXXX(XXX)X	17	319

PROJECT FILE NO. 608164

CONSTRUCTION PLANS

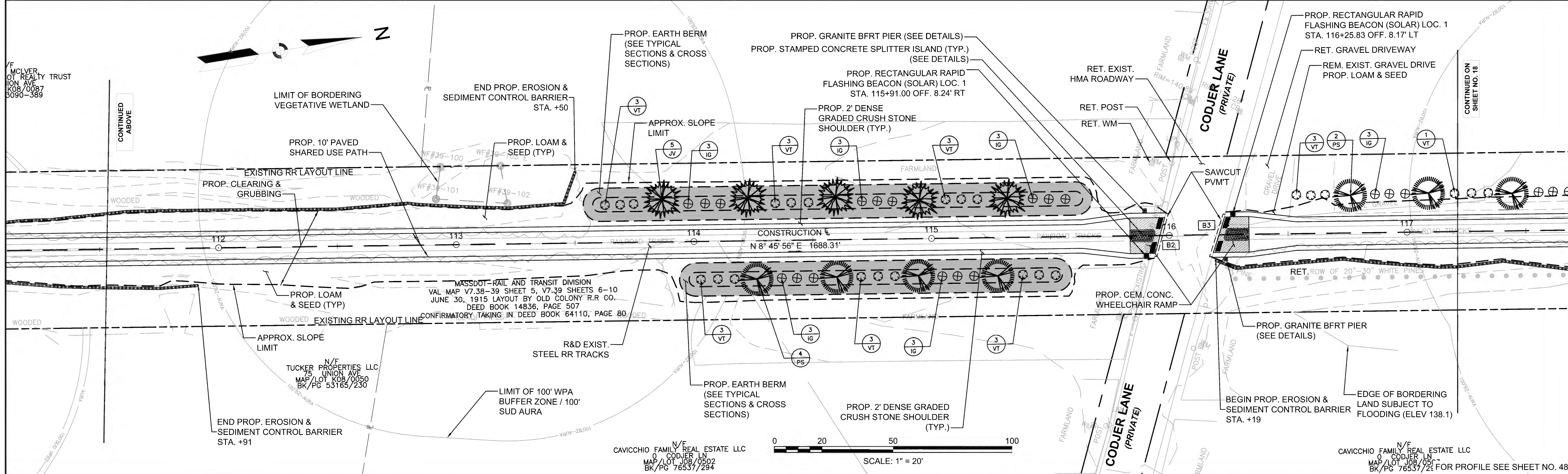
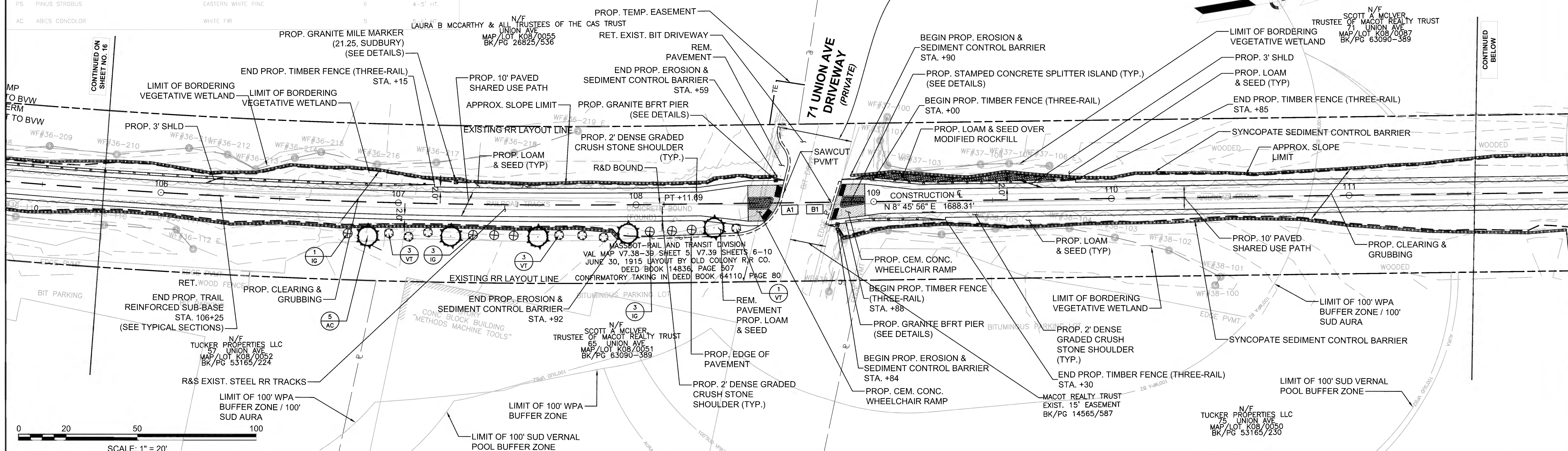

FENCING DETAILS

TIMBER FENCE (THREE-RAIL) STA. 119+75 LT TO STA. 132+25 LT
TIMBER FENCE (THREE-RAIL) STA. 119+75 RT TO STA. 130+75 RT

HIGHWAY GUARD DETAILS

NONE

WATER SUPPLY ALTERATIONS

NONE

TRAFFIC SIGNAL CONDUIT

NONE

DRAINAGE DETAILS

NONE

PLANT LIST

KEY	BOTANICAL NAME	COMMON NAME	QTY.	SIZE
	VISUAL SCREEN MIX			
VT	VILBURUM TRILOBUM	HIGHBUSH CRANBERRY	8	3 GAL.
IG	ILEX GLABRA	INKBERRY	9	3 GAL.
PS	PINUS STROBUS	EASTERN WHITE PINE	6	4-5' HT.
	EROSION CONTROL MIX			
SS	CAREX STRICTA	TUSsock SEDGE	49	PLUG
CS	CORNUS SERICEA & SALIX SSP	DOGWOOD AND WILLOW	5	1 GAL.

LEGEND:

PROPOSED WHEELCHAIR RAMP DETAIL #
PLANT QUANTITY AND SPECIES

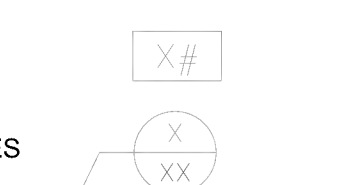

SUDBURY
BRUCE FREEMAN RAIL TRAIL

STATE	FED. AID PROJ. NO.	SHEET NO.	TOTAL SHEETS
MA	XXX-XXXX(XXX)X	18	319

PROJECT FILE NO. 608164
CONSTRUCTION PLANS

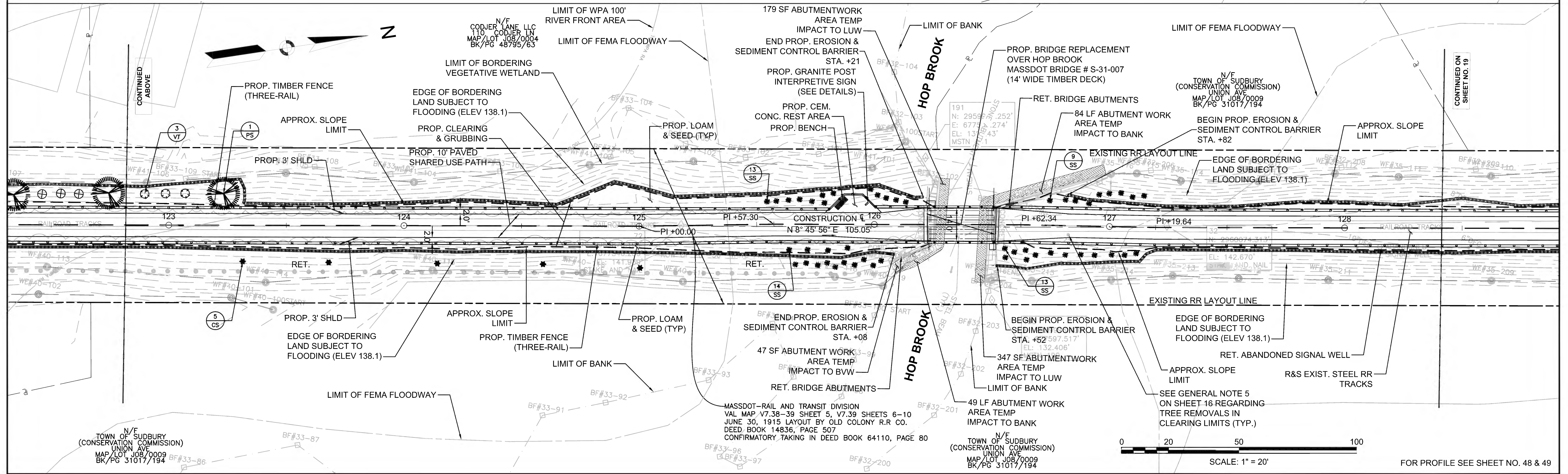
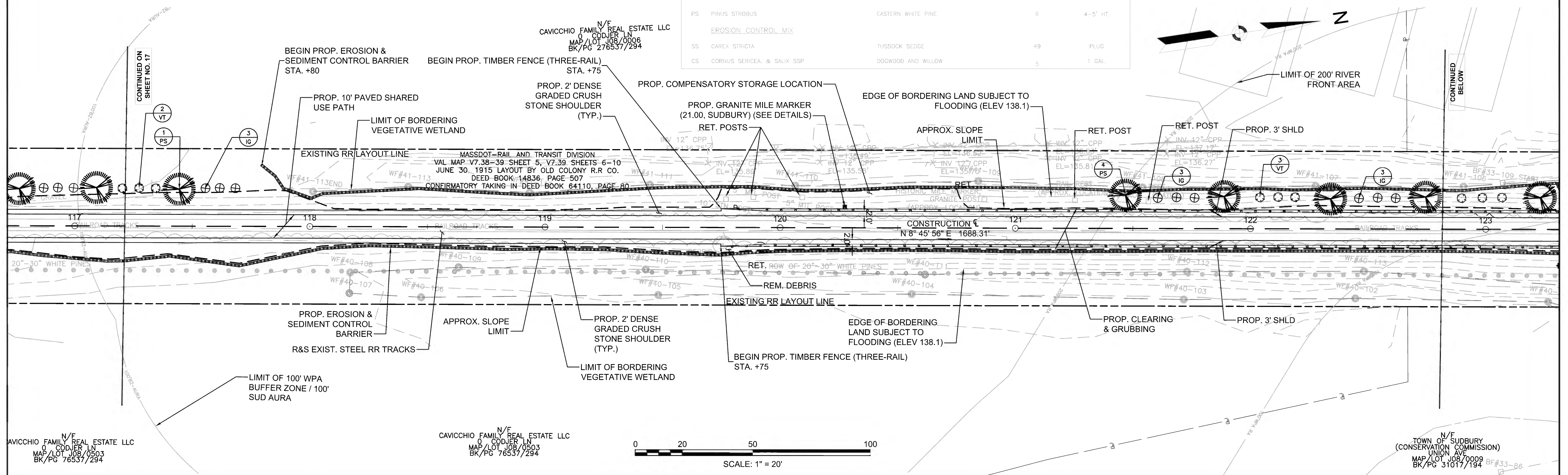

FENCING DETAILS

TIMBER FENCE (THREE-RAIL) STA. 119+75 LT TO STA. 132+25 LT
 TIMBER FENCE (THREE-RAIL) STA. 119+75 RT TO STA. 130+75 RT

HIGHWAY GUARD DETAILS

NONE

TRAFFIC SIGNAL CONDUIT

NONE

WATER SUPPLY ALTERATIONS

NONE

DRAINAGE DETAILS

NONE

PLANT LIST

KEY	BOTANICAL NAME	COMMON NAME	QTY.	SIZE
	VISUAL SCREEN MIX			
VT	VILBURUM TRILOBUM	HIGHBUSH CRANBERRY	12	3 GAL.
IG	ILEX GLABRA	INKBERRY	6	3 GAL.
AC	ABIES CONCOLOR	WHITE FIR	8	5'-6" HT.

LEGEND:

PROPOSED WHEELCHAIR RAMP DETAIL #
 PLANT QUANTITY AND SPECIES

SUDBURY
 BRUCE FREEMAN TRAIL

STATE	FED. AID PROJ. NO.	SHEET NO.	TOTAL SHEETS
MA	XXX-XXXX(XXX)X	19	319

PROJECT FILE NO. 608164

CONSTRUCTION PLANS

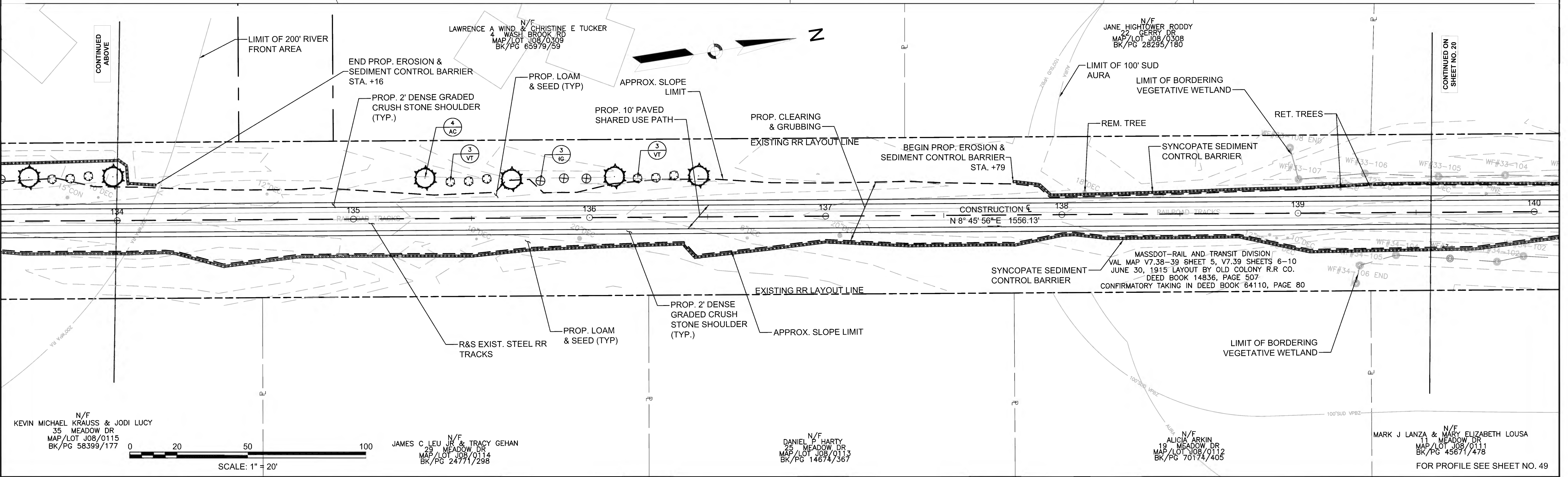
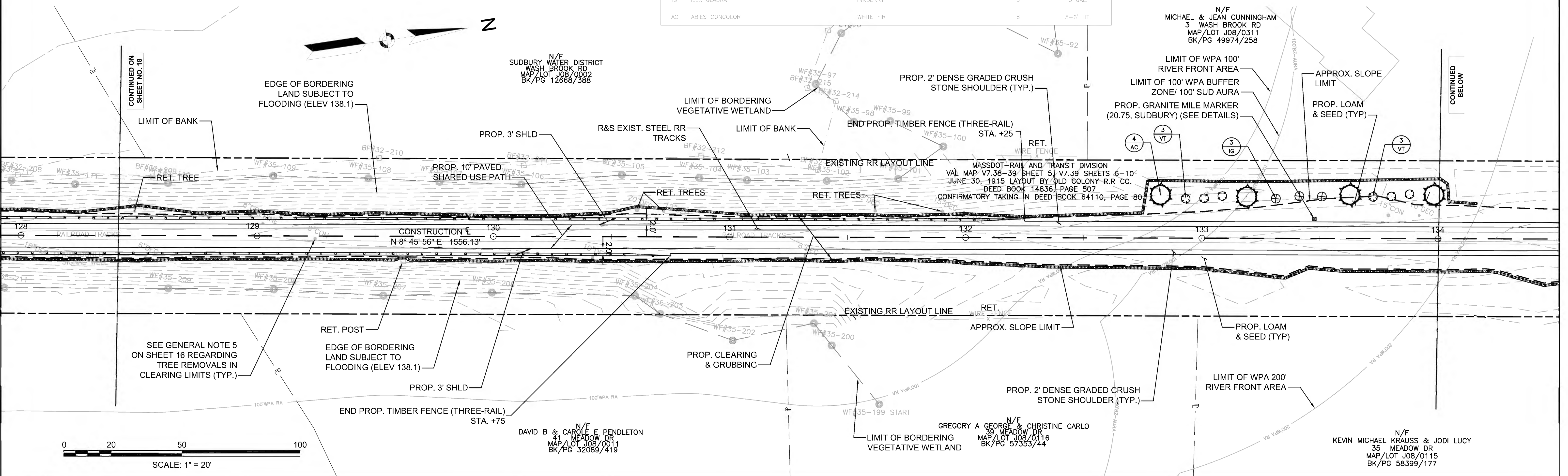

FENCING DETAILS
NONE

HIGHWAY GUARD DETAILS
NONE

WATER SUPPLY ALTERATIONS
NONE

TRAFFIC SIGNAL CONDUIT
NONE

DRAINAGE DETAILS
NONE

PLANT LIST

KEY	BOTANICAL NAME	COMMON NAME	QTY.	SIZE
VISUAL SCREEN MIX				
VT	VIBURNUM TRILOBUM	HIGHBUSH CRANBERRY	27	3 GAL.
IG	ILEX GLABRA	INKBERRY	24	3 GAL.
PS	PINUS STROBUS	EASTERN WHITE PINE	10	4-5' HT.
AC	ABIES CONCOLOR	WHITE FIR	8	5-6' HT.
ORNAMENTAL MIX				
CCR	CERCIS CANADENSIS	REDBUD	8	2-3" CAL.
HA	HYDRANGEA ARBORESCENS	SMOOTH HYDRANGEA	6	3 GAL.

LEGEND:

PROPOSED WHEELCHAIR RAMP DETAIL #

X#

XX

PLANT QUANTITY AND SPECIES

SUDBURY BRUCE FREEMAN RAIL TRAIL

STATE	FED. AID PROJ. NO.	SHEET NO.	TOTAL SHEETS
MA	XXX-XXXX(XXX)X	20	319

PROJECT FILE NO. 608164

CONSTRUCTION PLANS

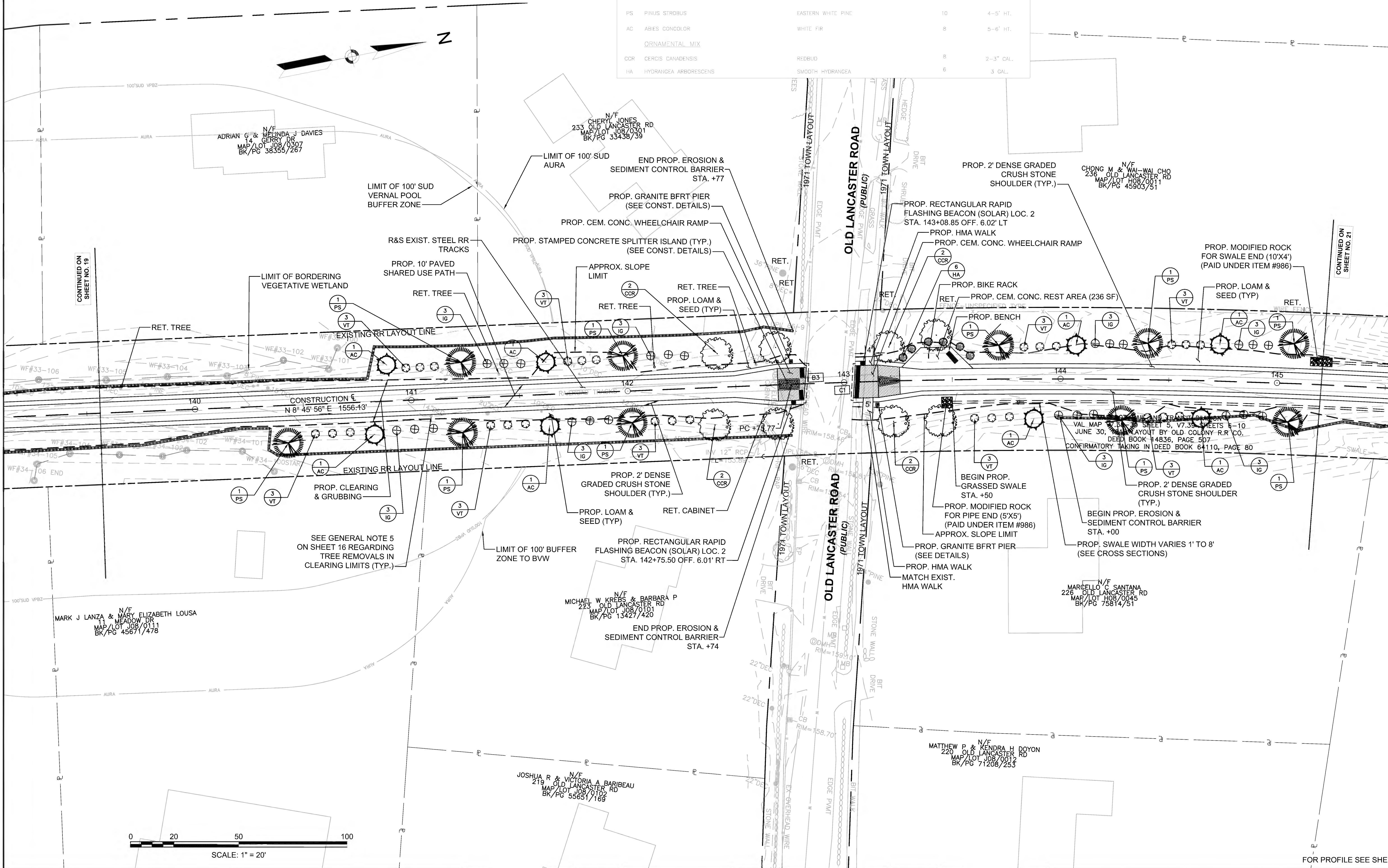

CONTINUED ON SHEET NO. 19

CONTINUED ON SHEET NO. 21

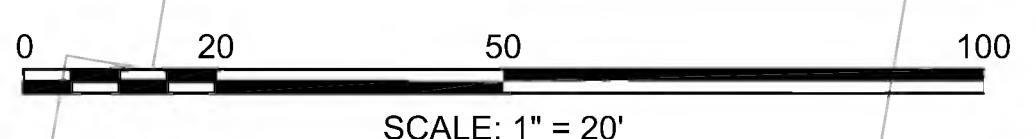

FOR PROFILE SEE SHEET NO. 49

FENCING DETAILS

TIMBER FENCE (THREE-RAIL) STA. 159+25 LT TO STA. 162+90 LT
 TIMBER FENCE (THREE-RAIL) STA. 158+25 RT TO STA. 161+25 RT
 TIMBER FENCE (THREE-RAIL) STA. 166+75 RT TO STA. 167+50 RT
 TIMBER FENCE (THREE-RAIL) STA. 166+75 RT TO STA. 167+50 RT

HIGHWAY GUARD DETAILS

NONE

WATER SUPPLY ALTERATIONS

SHEET 180

TRAFFIC SIGNAL CONDUIT

NONE

DRAINAGE DETAILS

SHEET 180

PLANT LIST

KEY	BOTANICAL NAME	COMMON NAME	QTY.	SIZE
EROSION CONTROL MIX				
SS	CAREX STRICTA	TUSsock SEDGE	7	PLUG
ORNAMENTAL MIX				
CCR	CERCIS CANADENSIS	REDBUD	2	2-3" CAL.
HA	HYDRANGEA ARBORESCENS	SMOOTH HYDRANGEA	2	5 CAL.

LEGEND:

PROPOSED WHEELCHAIR RAMP DETAIL #

PLANT QUANTITY AND SPECIES

SUDBURY BRUCE FREEMAN TRAIL

STATE	FED. AID PROJ. NO.	SHEET NO.	TOTAL SHEETS
MA	XXX-XXXX(XXX)X	22	319

PROJECT FILE NO. 608164

CONSTRUCTION PLANS

JAMES C & MELANIE B WEAVER
 248 OLD LANCASTER RD
 MAP/LOT H08/0008
 BK/PG 12967/255

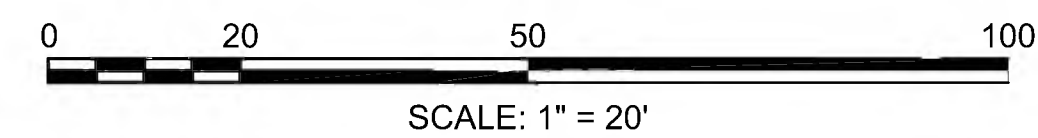
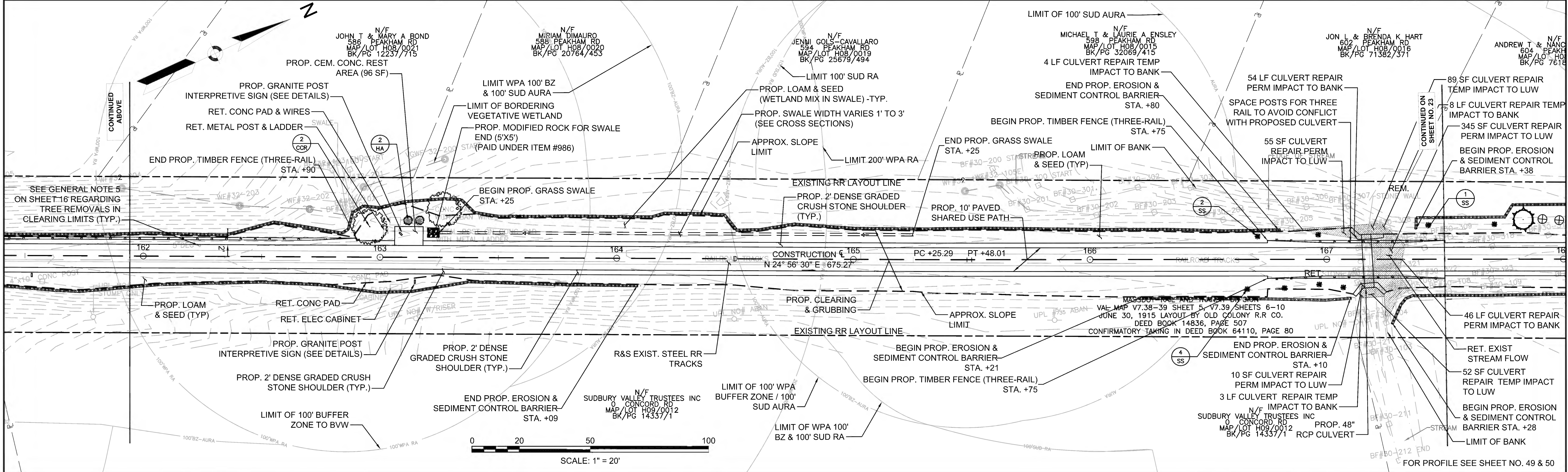
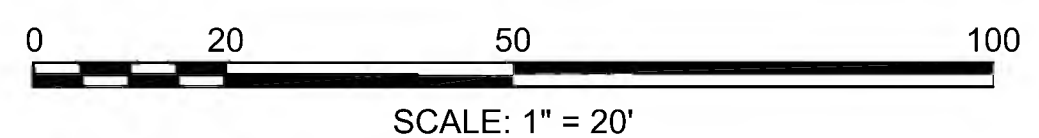
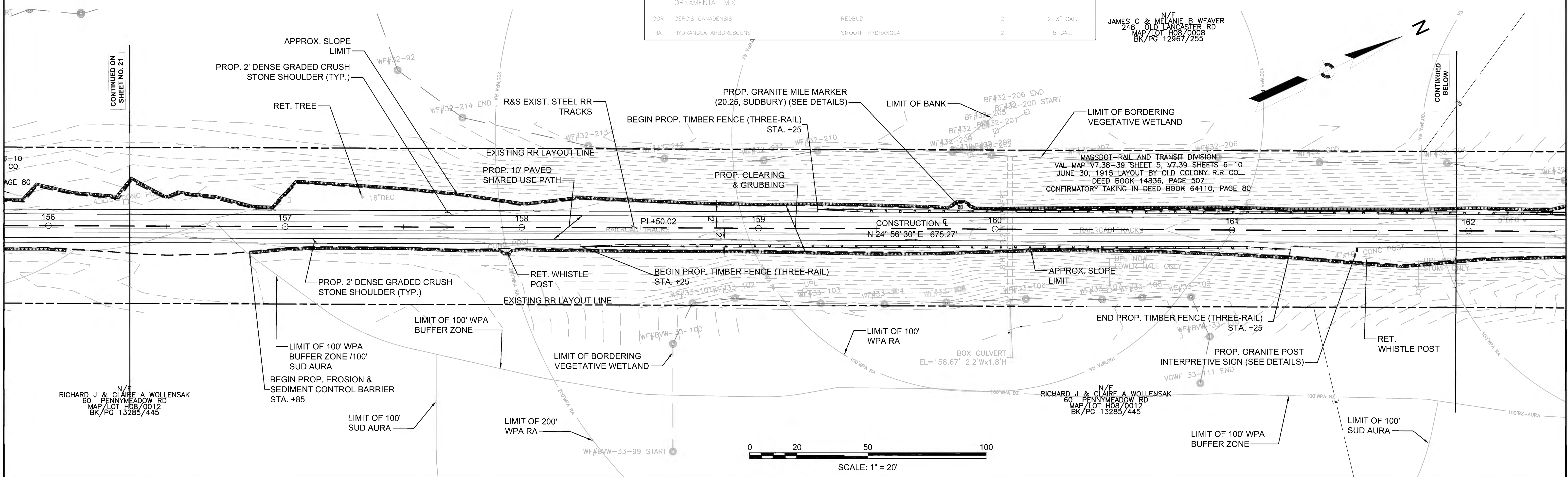

FOR PROFILE SEE SHEET NO. 49 & 50

FENCING DETAILS

HIGHWAY GUARD DETAILS

TRAFFIC SIGNAL CONDUIT

WATER SUPPLY ALTERATIONS

DRAINAGE DETAILS

LEGEND:

PROPOSED WHEELCHAIR RAMP DETAIL #

PLANT QUANTITY AND SPECIES

BRUCE FREEMAN RAIL TRAIL

STATE	FED. AID PROJ. NO.	SHEET NO.	TOTAL SHEETS
MA	XXX-XXXX(XXX)X	24	319
PROJECT FILE NO.		608164	

CONSTRUCTION PLANS

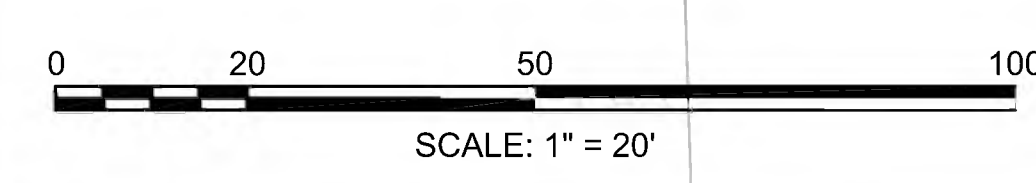
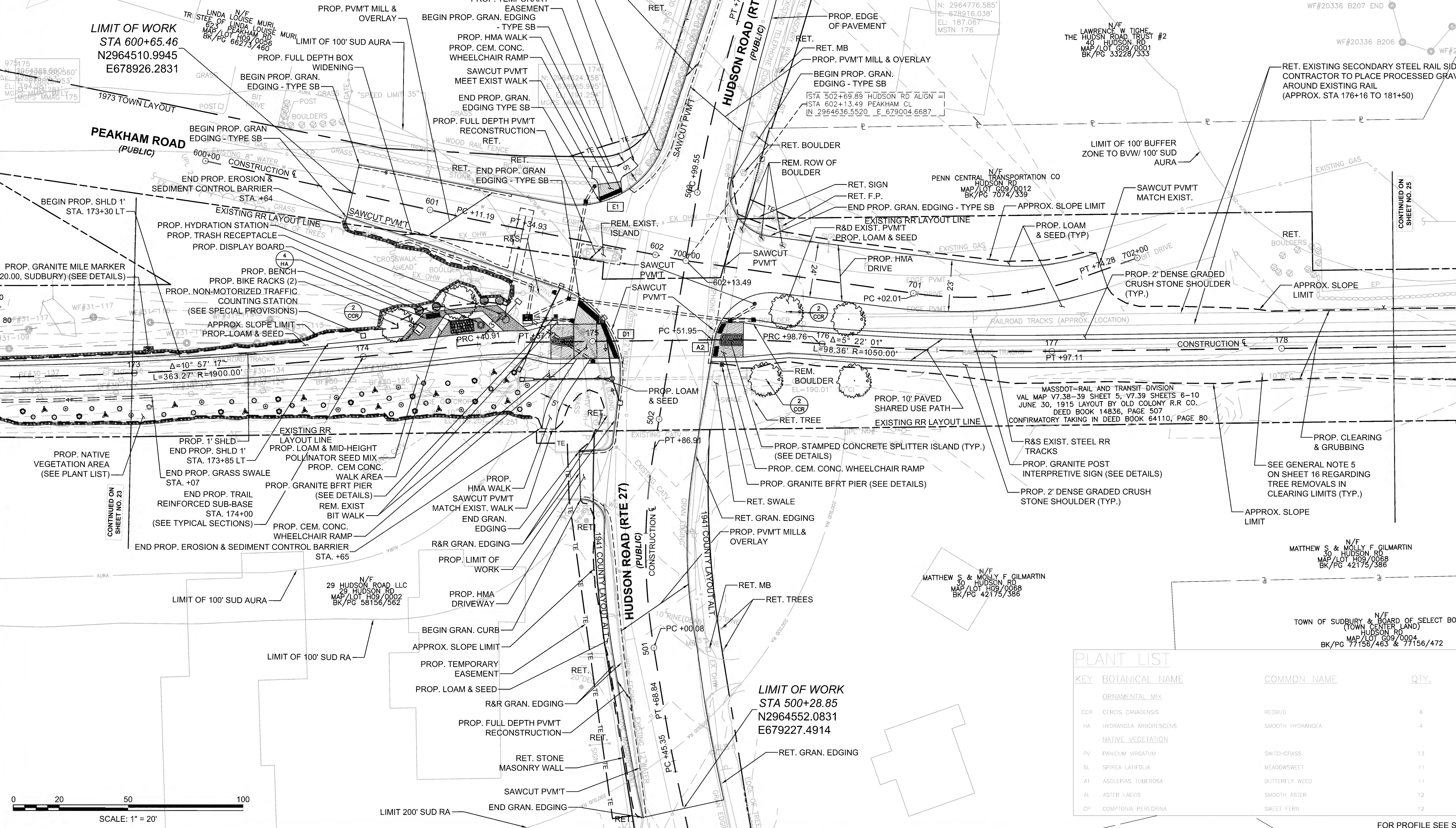
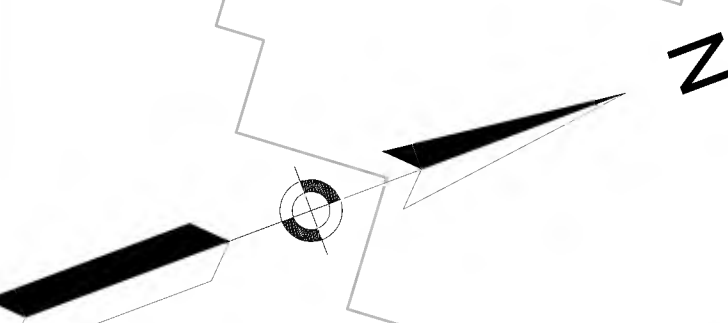
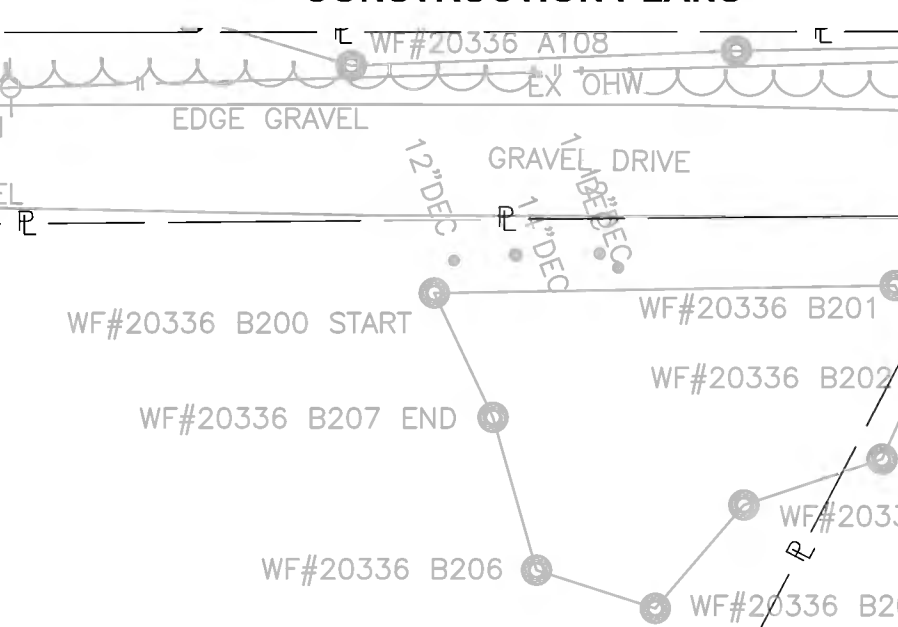

PLANT LIST

KEY	BOTANICAL NAME	COMMON NAME	QTY.	SIZE
	ORNAMENTAL MIX			
CCR	CERCIS CANADENSIS	REDBUD	6	2-3" CAL.
HA	HYDRANGEA ARBORESCENS	SMOOTH HYDRANGEA	4	3 CAL.
	NATIVE VEGETATION			
PV	PANICUM VIRGATUM	SWITCHGRASS	13	PLUG
SL	SPIREA LATIFOLIA	MEADOWSWEET	11	PLUG
AT	ASCLEPIAS TUBEROSA	BUTTERFLY WEED	11	PLUG
AL	ASTER LAEVIS	SMOOTH ASTER	12	PLUG
CP	COMPTONIA PEREGRINA	SWEET FERN	12	PLUG

FOR PROFILE SEE SHEET NO. 51

608164 - HD(CONSTRUCTION PLANS).DWG Printed on 18-Feb-2022 9:06 PM

FENCING DETAILS

TIMBER FENCE (THREE-RAIL) STA. 186+50 RT TO STA. 190+90 RT
TIMBER FENCE (THREE-RAIL) STA. 190+15 LT TO STA. 190+90 LT
TIMBER FENCE (THREE-RAIL) STA. 196+75 RT TO STA. 198+70 RT
TIMBER FENCE (THREE-RAIL) STA. 196+75 LT TO STA. 199+15 LT

HIGHWAY GUARD DETAILS

NONE
WATER SUPPLY ALTERATIONS
NONE

TRAFFIC SIGNAL CONDUIT

NONE
DRAINAGE DETAILS
NONE

PLANT LIST

KEY	BOTANICAL NAME	COMMON NAME	QTY.	SIZE
ORNAMENTAL MIX				
ACS	AMELANCHIER CANADENSIS	CANADIAN SERVICEBERRY	2	2-3" CAL.
HA	HYDRANGEA ARBORESCENS	SMOOTH HYDRANGEA	4	3 GAL.

LEGEND:

PROPOSED WHEELCHAIR RAMP DETAIL #
PLANT QUANTITY AND SPECIES

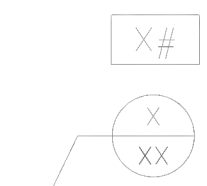

SUDBURY
BRUCE FREEMAN RAIL TRAIL

STATE	FED. AID PROJ. NO.	SHEET NO.	TOTAL SHEETS
MA	XXX-XXXX(XXX)X	26	319

PROJECT FILE NO. 608164
CONSTRUCTION PLANS

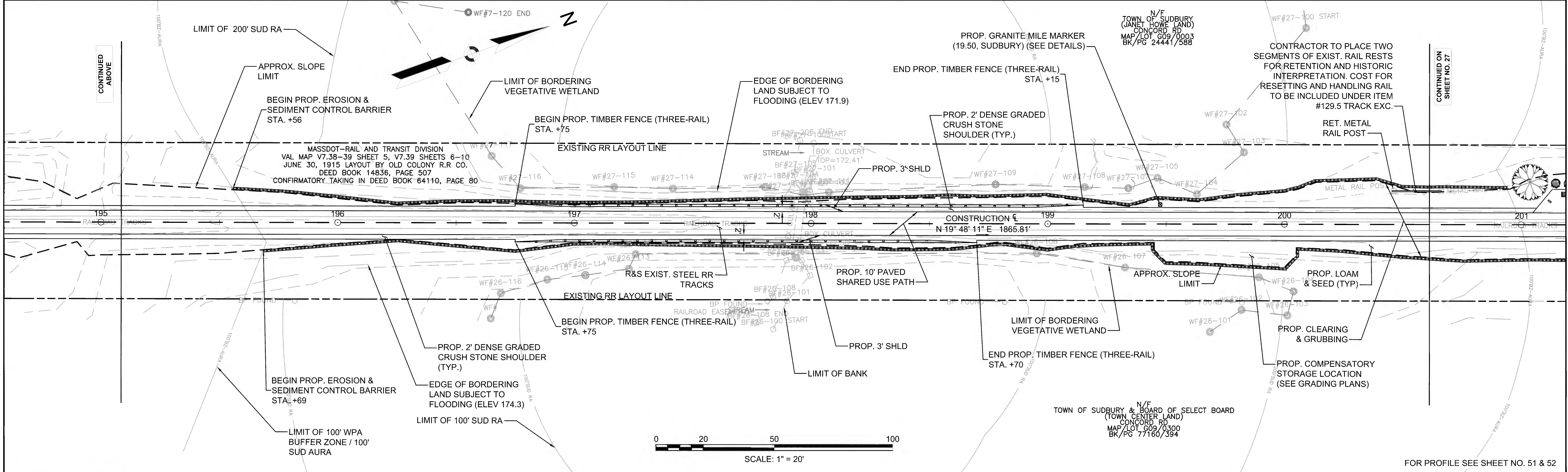
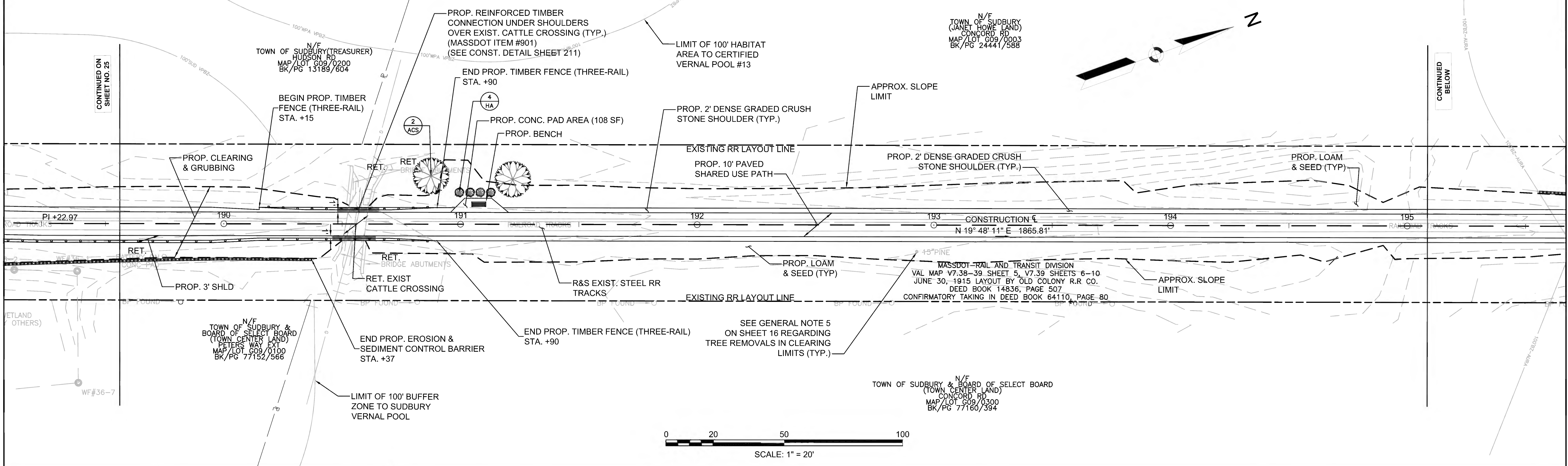

FOR PROFILE SEE SHEET NO. 51 & 52

HIGHWAY GUARD DETAILS

NONE

TRAFFIC SIGNAL CONDUIT

NONE

WATER SUPPLY ALTERATIONS

NONE

DRAINAGE DETAILS

NONE

PLANT LIST

KEY	BOTANICAL NAME	COMMON NAME	QTY.	SIZE
ORNAMENTAL MIX				
ACS	AMELANCHIER CANADENSIS	CANADIAN SERVICEBERRY	2	2-3" CAL.
HA	HYDRANGEA ARBORESCENS	SMOOTH HYDRANGEA	5	3 CAL.

LEGEND:

PROPOSED WHEELCHAIR RAMP DETAIL #

SUDBURY BRUCE FREEMAN RAIL TRAIL

STATE	FED. AID PROJ. NO.	SHEET NO.	TOTAL SHEETS
MA	XXX-XXXX(XXX)X	27	319

PROJECT FILE NO. 608164

CONSTRUCTION PLANS

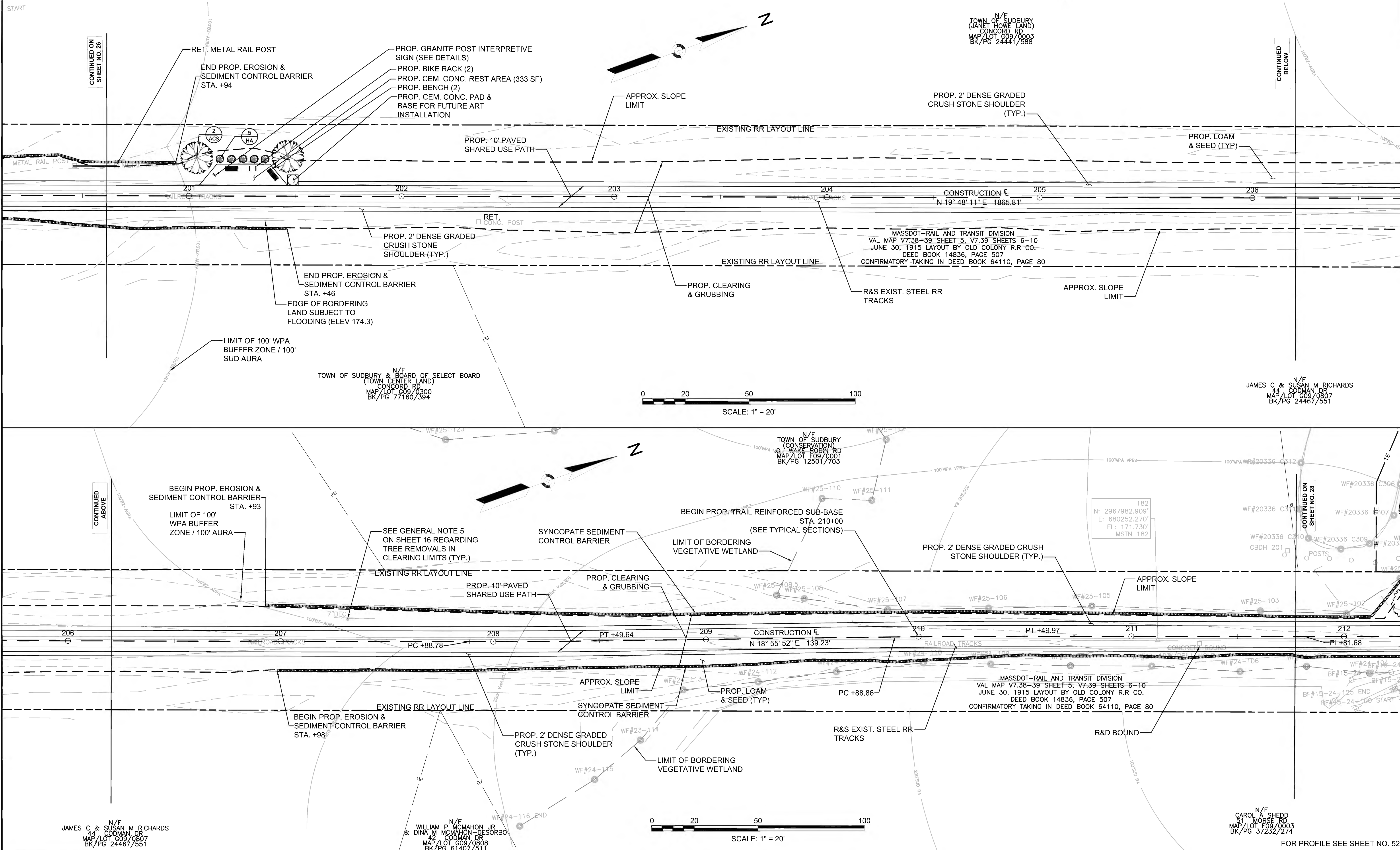

Plotted on 18-Feb-2022 9:08 PM

608164_HDCONSTRUCTION PLANS.DWG

JAMES C & SUSAN M RICHARDS
44 CODMAN DR
MAP/LOT 609/0807
BK/PG 2446/551

WILLIAM P MCMAHON JR
& DINA M MCMAHON-DESORBO
42 CODMAN DR
MAP/LOT 609/0808
BK/PG 6140/511

CAROL A SHEDD
51 MORSE RD
MAP/LOT 609/0003
BK/PG 37232/274

FOR PROFILE SEE SHEET NO. 52

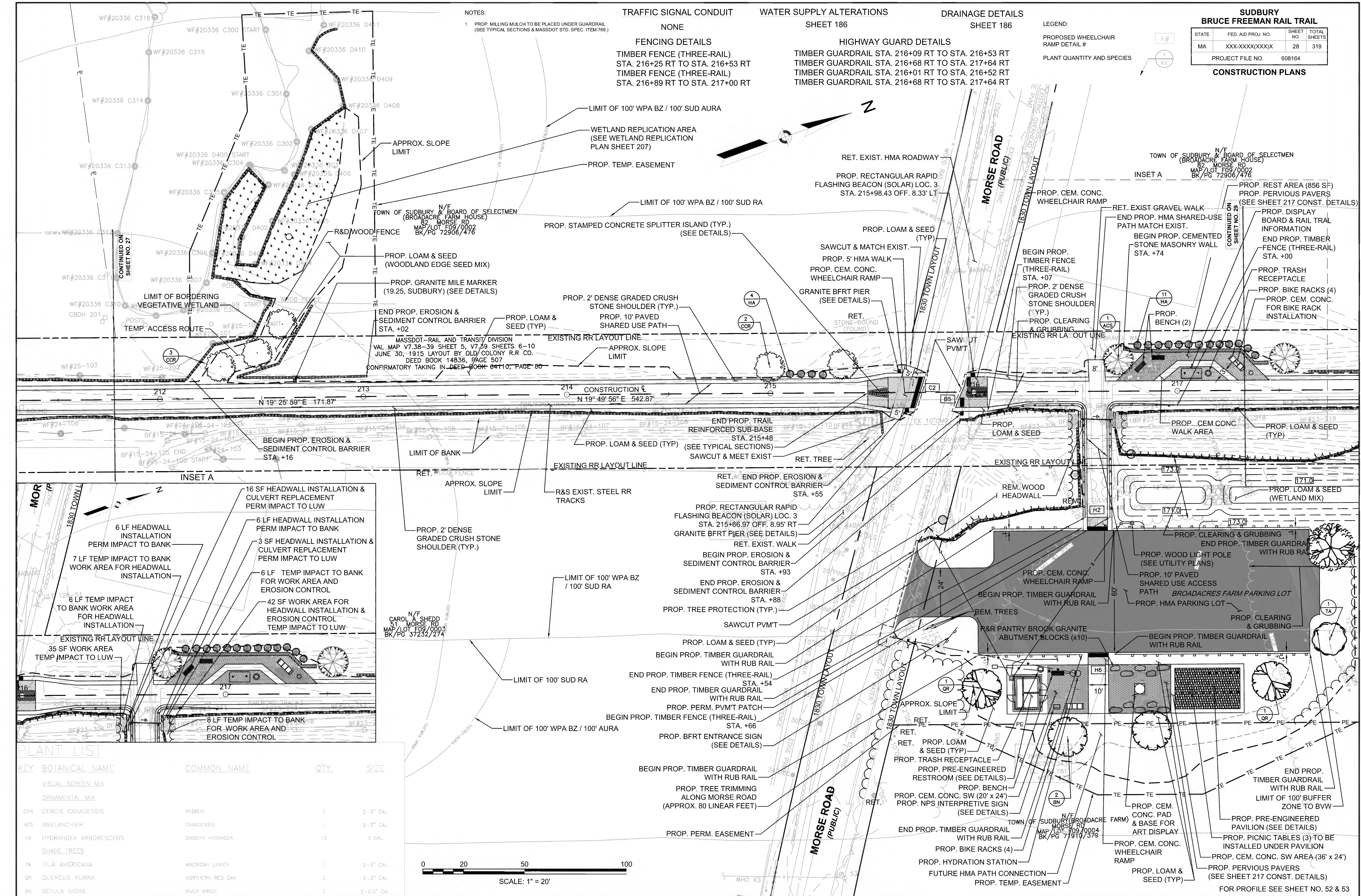

608164 - HD(CONSTRUCTION PLANS).DWG Plotted on 18-Feb-2022 9:08 PM

FENCING DETAILS

TIMBER FENCE (THREE-RAIL) STA. 222+25 LT TO STA. 231+73 LT
 TIMBER FENCE (THREE-RAIL) STA. 224+23 RT TO STA. 228+73 RT

HIGHWAY GUARD DETAILS

NONE

WATER SUPPLY ALTERATIONS

NONE

PLANT LIST

KEY	BOTANICAL NAME	COMMON NAME	QTY.	SIZE
ORNAMENTAL MIX				
ACS	AMELANCHIER	CANADENSIS	1	2-3" CAL.
HA	HYDRANGEA ARBORESCENS	SMOOTH HYDRANGEA	2	3 GAL.
SHADE TREES				
AS	ACER SACCHARUM	SUGAR MAPLE	1	2-3" CAL.

TRAFFIC SIGNAL CONDUIT

NONE

DRAINAGE DETAILS

NONE

LEGEND:

PROPOSED WHEELCHAIR RAMP DETAIL #
 PLANT QUANTITY AND SPECIES

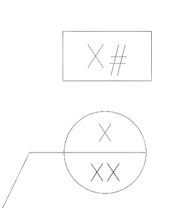

SUBURRY
BRUCE FREEMAN RAIL TRAIL

STATE	FED. AID PROJ. NO.	SHEET NO.	TOTAL SHEETS
MA	XXX-XXXX(XXX)X	29	319

PROJECT FILE NO. 608164
CONSTRUCTION PLANS

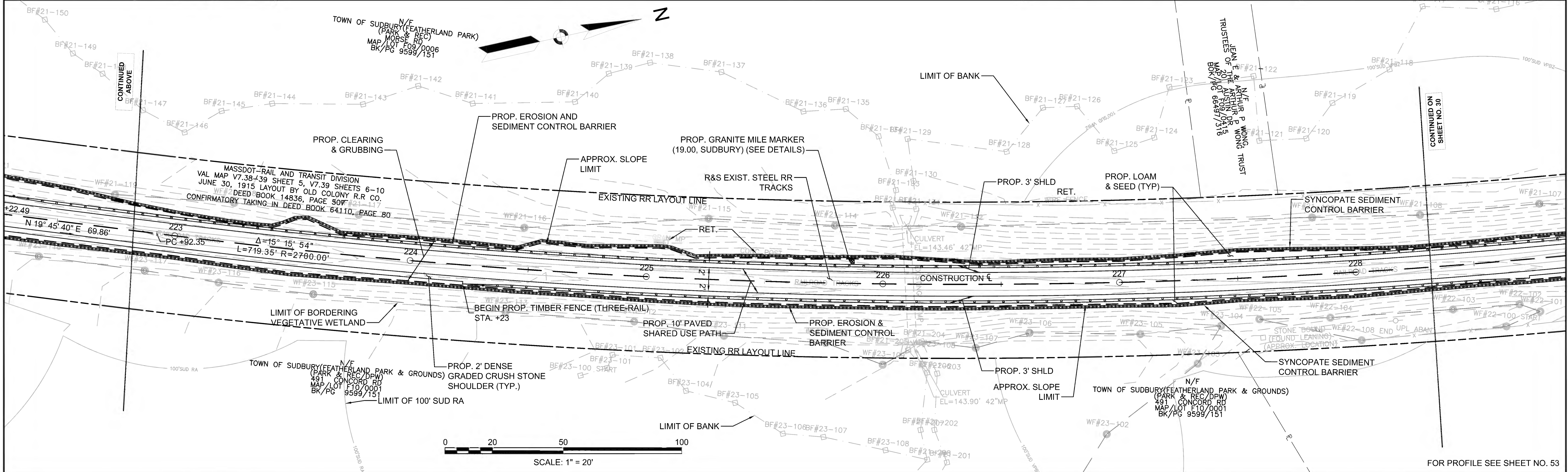
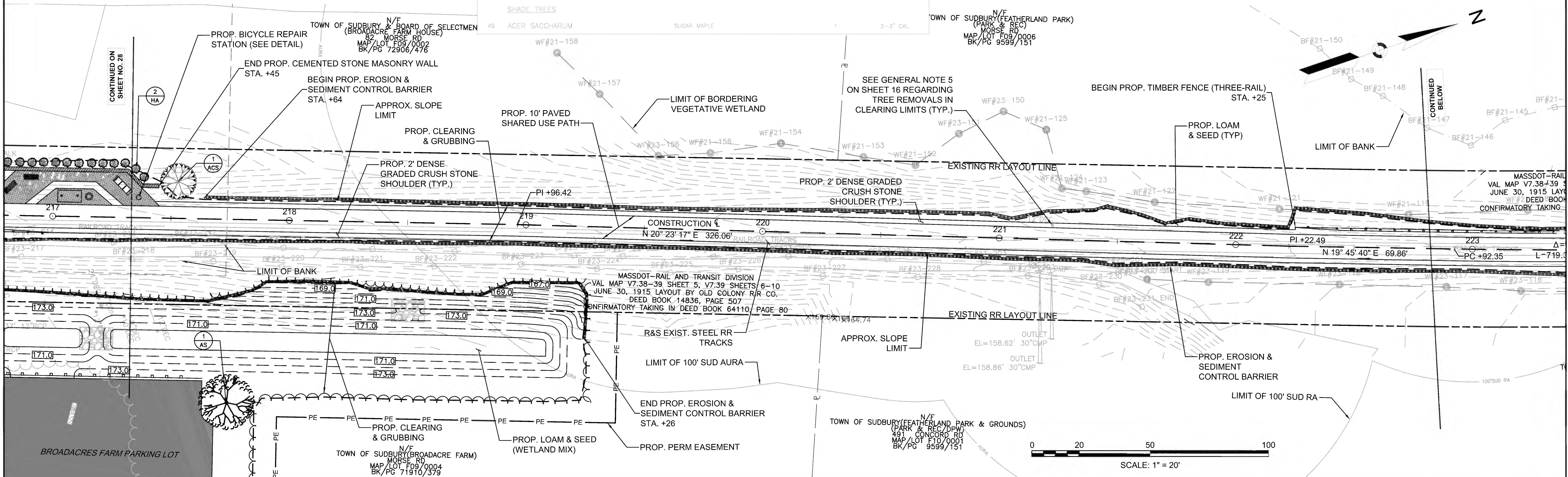

FOR PROFILE SEE SHEET NO. 53

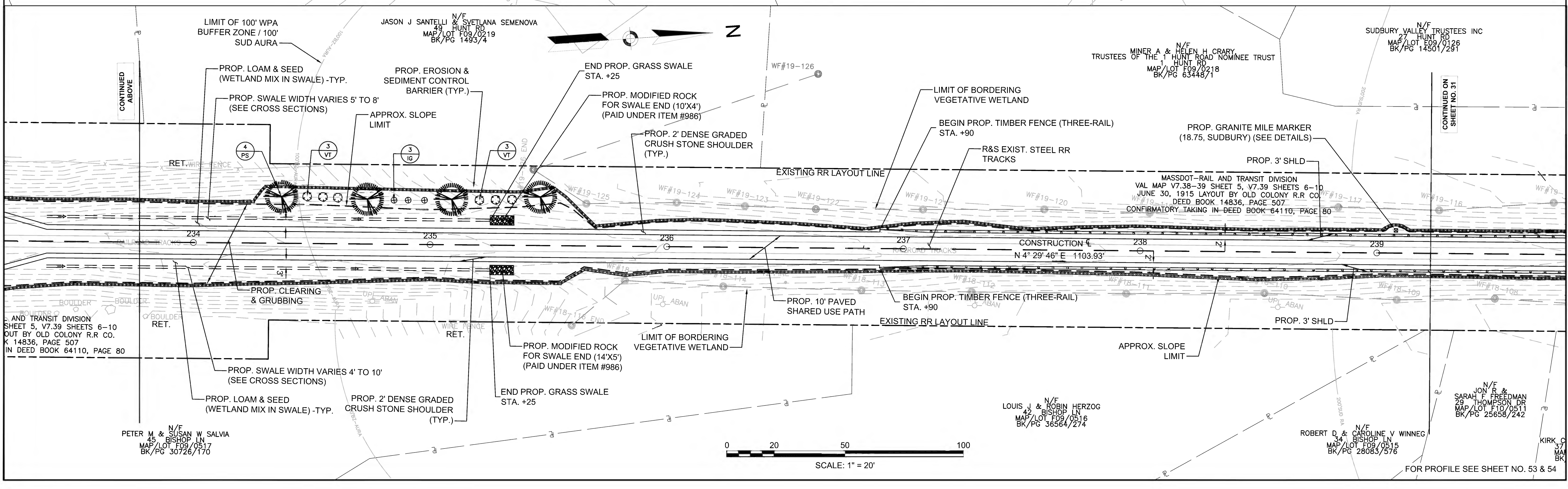
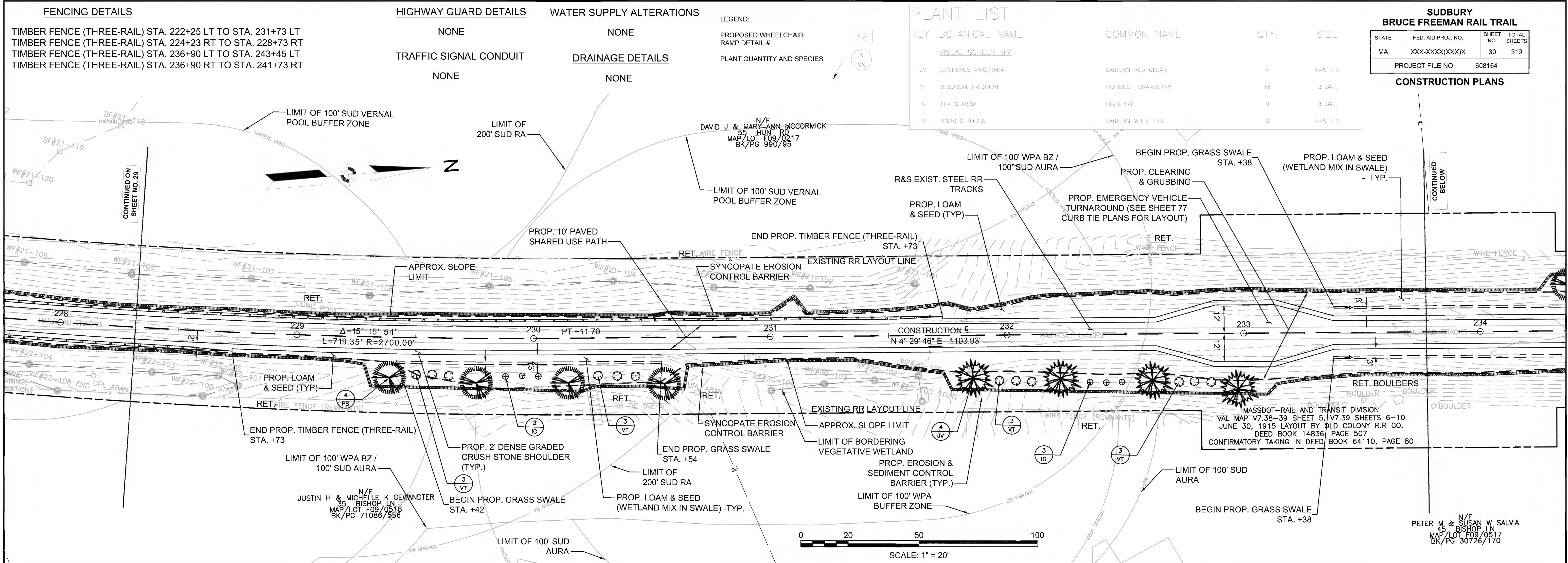

FENCING DETAILS

TIMBER FENCE (THREE-RAIL) STA. 236+90 LT TO STA. 243+45 LT
 TIMBER FENCE (THREE-RAIL) STA. 236+90 RT TO STA. 241+73 RT
 TIMBER FENCE (THREE-RAIL) STA. 245+75 LT TO STA. 248+30 LT
 TIMBER FENCE (THREE-RAIL) STA. 245+75 RT TO STA. 248+30 RT

HIGHWAY GUARD DETAILS

NONE

TRAFFIC SIGNAL CONDUIT

NONE

WATER SUPPLY ALTERATIONS

NONE

DRAINAGE DETAILS

NONE

PLANT LIST

KEY	BOTANICAL NAME	COMMON NAME	QTY.	SIZE
VT	VIBURNUM TRILOBUM	HIGHBUSH CRANBERRY	19	3 GAL.
IG	ILEX GLABRA	INKBERRY	13	3 GAL.
PS	PINUS STROBUS	EASTERN WHITE PINE	9	4-5' HT.
AC	ABIES CONCOLOR	WHITE FIR	5	5-6' HT.
ORNAMENTAL MIX				
ACS	AMELANCHIER	CANAENSIS	2	2-3" CAL.
HA	HYDRANGEA ARBORESCENS	SMOOTH HYDRANGEA	4	3 GAL.

LEGEND:

PROPOSED WHEELCHAIR RAMP DETAIL # X#
 PLANT QUANTITY AND SPECIES X XX

SUDBURY
BRUCE FREEMAN RAIL TRAIL

STATE	FED. AID PROJ. NO.	SHEET NO.	TOTAL SHEETS
MA	XXX-XXXX(XXX)X	31	319
PROJECT FILE NO.		608164	

CONSTRUCTION PLANS

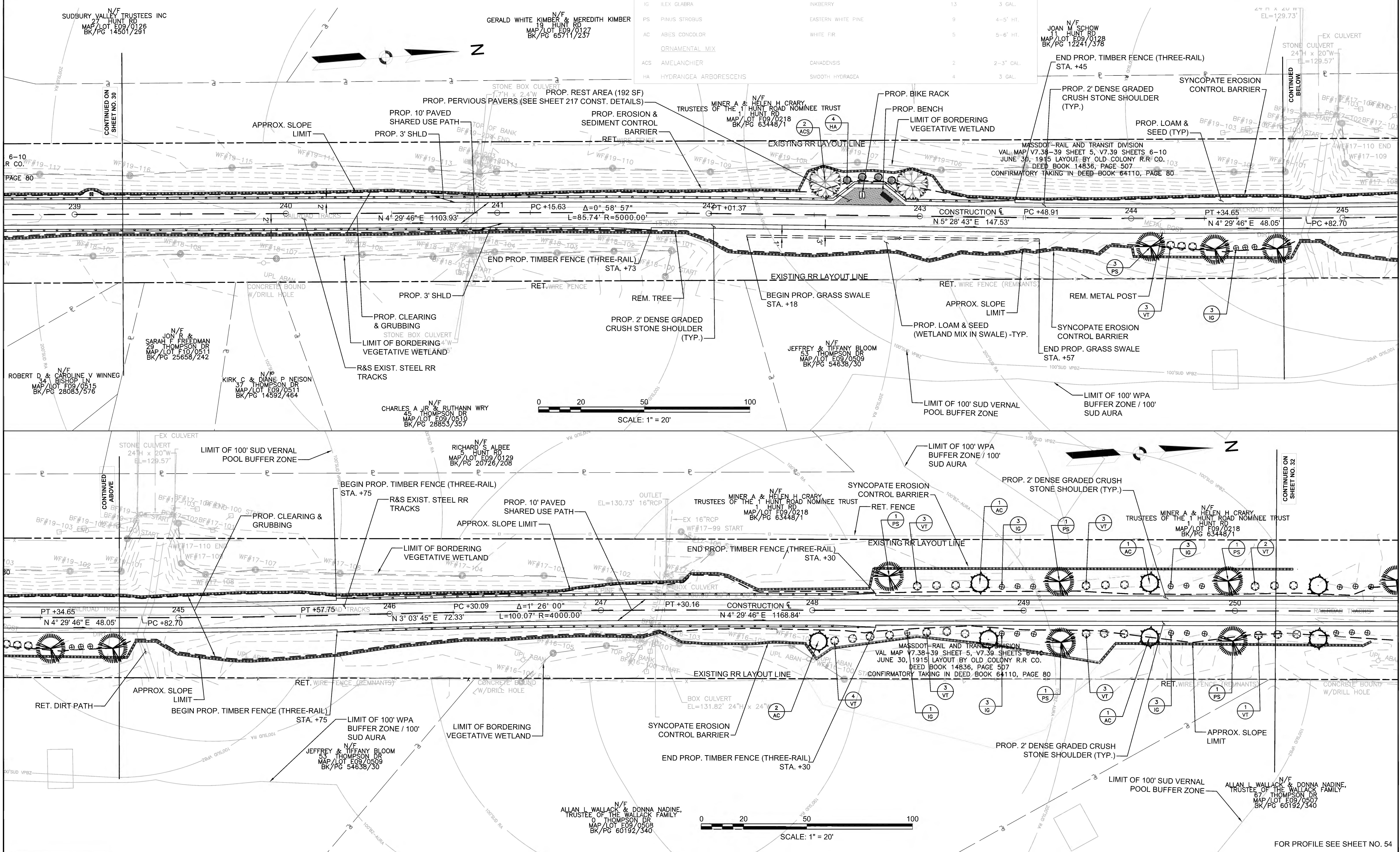

FOR PROFILE SEE SHEET NO. 54

FENCING DETAILS
 TIMBER FENCE (THREE-RAIL) STA. 258+22 RT TO STA. 258+72 RT
 TIMBER FENCE (THREE-RAIL) STA. 258+22 LT TO STA. 258+72 LT

HIGHWAY GUARD DETAILS
 NONE

TRAFFIC SIGNAL CONDUIT
 NONE

WATER SUPPLY ALTERATIONS
 NONE

DRAINAGE DETAILS
 SHEET 190

PLANT LIST

KEY	BOTANICAL NAME	COMMON NAME	QTY.	SIZE
	VISUAL SCREEN MIX			
VT	VIBURNUM TRILOBUM	HIGHBUSH CRANBERRY	6	3 GAL
IG	ILEX GLABRA	INKBERRY	6	3 GAL
PS	PINUS STROBUS	EASTERN WHITE PINE	1	4-5' HT.
AC	ABIES CONCOLOR	WHITE FIR	2	5-6' HT.

LEGEND:

PROPOSED WHEELCHAIR RAMP DETAIL #

PLANT QUANTITY AND SPECIES

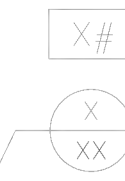

SUDBURY
BRUCE FREEMAN RAIL TRAIL

STATE	FED. AID PROJ. NO.	SHEET NO.	TOTAL SHEETS
MA	XXX-XXXX(XXX)X	32	319

PROJECT FILE NO. 608164

CONSTRUCTION PLANS

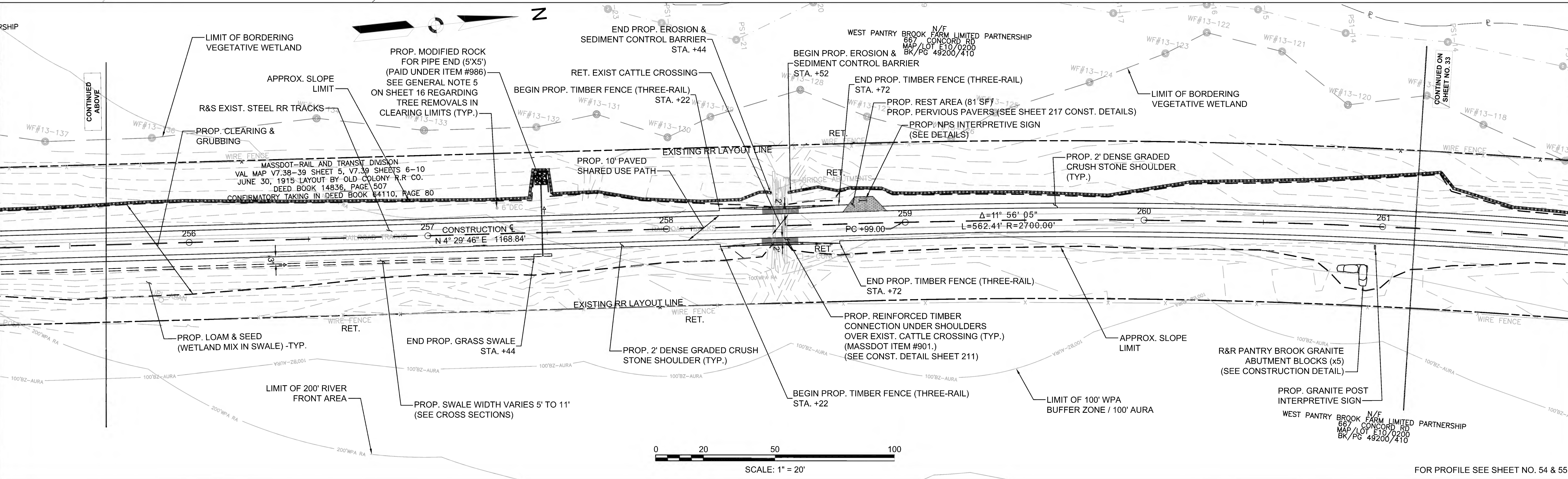
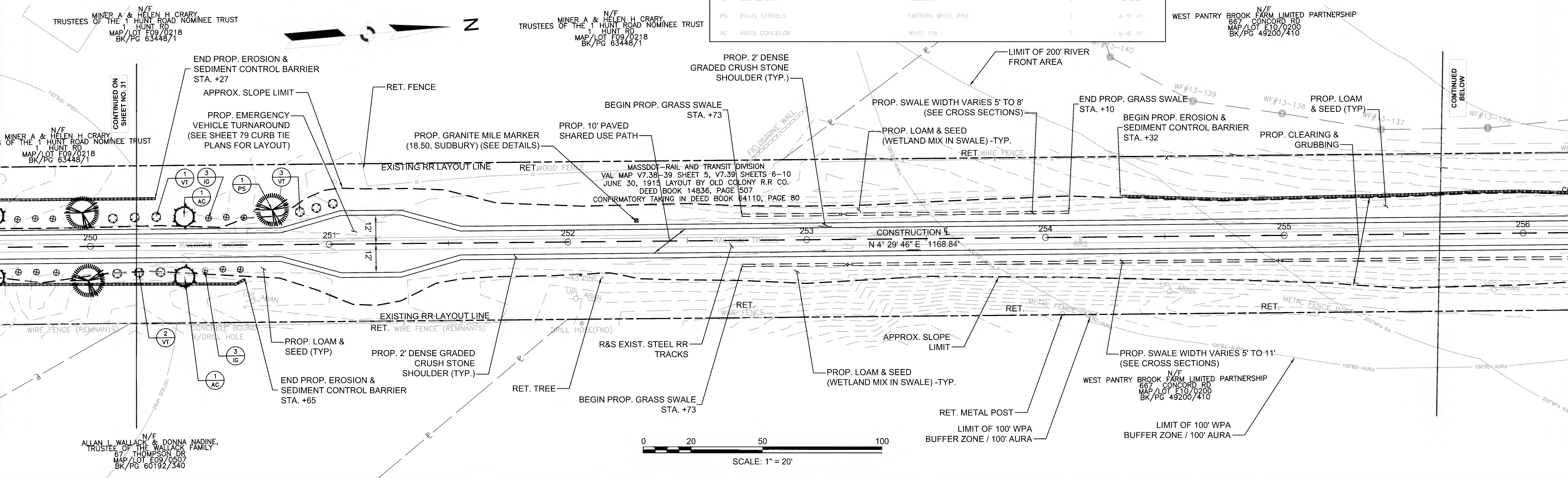

FOR PROFILE SEE SHEET NO. 54 & 55

FENCING DETAILS

TIMBER FENCE (THREE-RAIL) STA. 262+25 LT TO STA. 266+25 LT
TIMBER FENCE (THREE-RAIL) STA. 264+00 RT TO STA. 268+75 RT
TIMBER FENCE (THREE-RAIL) STA. 269+52 LT TO STA. 270+02 LT
TIMBER FENCE (THREE-RAIL) STA. 269+52 RT TO STA. 270+02 RT

HIGHWAY GUARD DETAILS

NONE

TRAFFIC SIGNAL CONDUIT

NONE

WATER SUPPLY ALTERATIONS

NONE

DRAINAGE DETAILS

NONE

PLANT LIST

KEY	BOTANICAL NAME	COMMON NAME	QTY.	SIZE
SS	CAREX STRICTA	RUSSOCK SEDGE	19	PLUG

LEGEND:

PROPOSED WHEELCHAIR RAMP DETAIL # X#
PLANT QUANTITY AND SPECIES X XX

SUDBURY BRUCE FREEMAN RAIL TRAIL

STATE	FED. AID PROJ. NO.	SHEET NO.	TOTAL SHEETS
MA	XXX-XXXX(XXX)X	33	319

PROJECT FILE NO. 608164

CONSTRUCTION PLANS

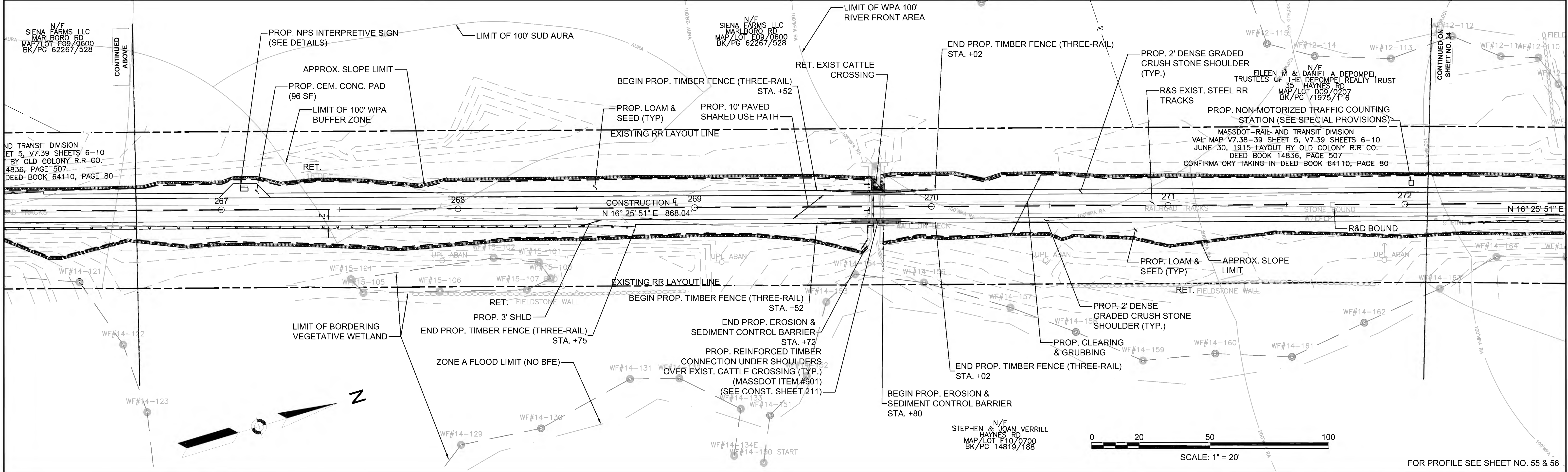
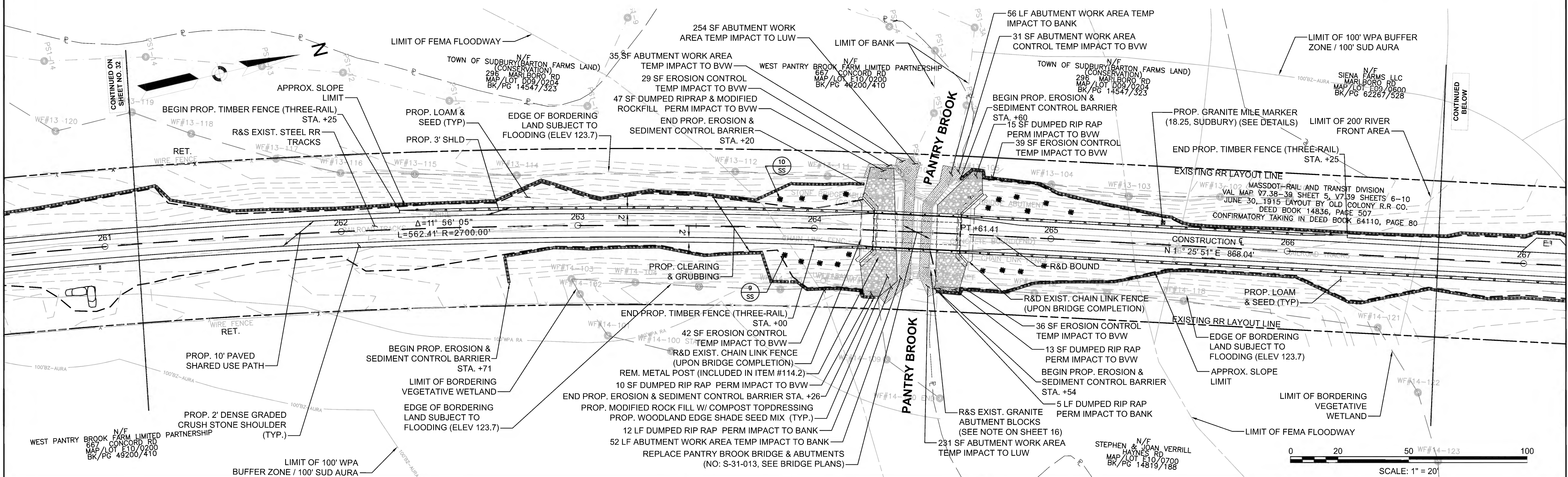

FOR PROFILE SEE SHEET NO. 55 & 56

FENCING DETAILS

TIMBER FENCE (THREE-RAIL) STA. 272+23 RT TO STA. 273+73 RT

HIGHWAY GUARD DETAILS

NONE

TRAFFIC SIGNAL CONDUIT

NONE

WATER SUPPLY ALTERATIONS

NONE

DRAINAGE DETAILS

NONE

PLANT LIST

KEY	BOTANICAL NAME	COMMON NAME	QTY.	SIZE
VISUAL SCREEN MIX				
VT	VIBURNUM TRILOBUM	HIGHBUSH CRANBERRY	6	3 GAL.
IG	ILEX GLABRA	INKBERRY	6	3 GAL.
PS	PINUS STROBUS	EASTERN WHITE PINE	1	4-5' HT.
AC	ABIES CONCOLOR	WHITE FIR	1	5-6' HT.
ORNAMENTAL MIX				
CCR	CERCIS CANADENSIS	REDBUD	6	2-3" CAL.
HA	HYDRANGEA ARBORESCENS	SMOOTH HYDRANGEA	4	3 GAL.

LEGEND:

PROPOSED WHEELCHAIR RAMP DETAIL #
PLANT QUANTITY AND SPECIES

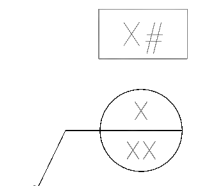

SUDBURY
BRUCE FREEMAN RAIL TRAIL

STATE	FED. AID PROJ. NO.	SHEET NO.	TOTAL SHEETS
MA	XXX-XXXX(XXX)X	34	319

PROJECT FILE NO. 608164

CONSTRUCTION PLANS

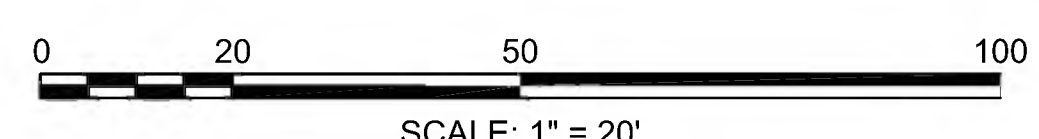
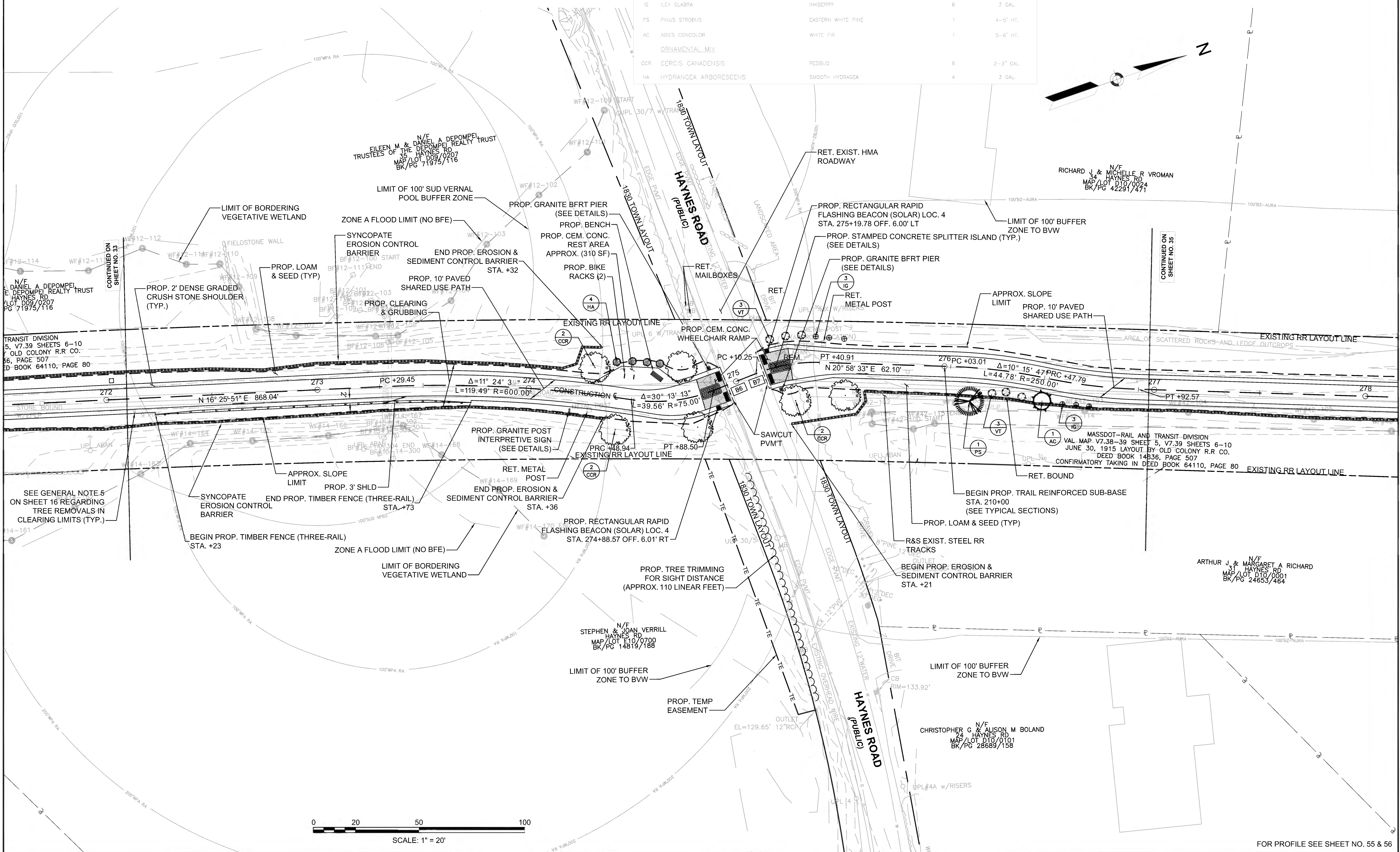

SCALE: 1" = 20'

FOR PROFILE SEE SHEET NO. 55 & 56

FENCING DETAILS

NONE

HIGHWAY GUARD DETAILS

NONE

TRAFFIC SIGNAL CONDUIT

NONE

WATER SUPPLY ALTERATIONS

NONE

DRAINAGE DETAILS

NONE

LEGEND:

PROPOSED WHEELCHAIR RAMP DETAIL #

PLANT QUANTITY AND SPECIES

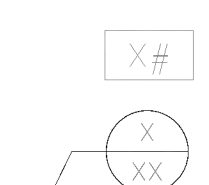

SUDBURY
BRUCE FREEMAN RAIL TRAIL

STATE	FED. AID PROJ. NO.	SHEET NO.	TOTAL SHEETS
MA	XXX-XXXX(XXX)X	35	319

CONSTRUCTION PLANS

PLANT LIST

KEY	BOTANICAL NAME	COMMON NAME	QTY.	SIZE
<u>VISUAL SCREEN MIX</u>				
VT	VIBURNUM TRILOBUM	HIGHBUSH CRANBERRY	6	3 GAL.
IG	ILEX GLABRA	INKBERRY	3	3 GAL.
PS	FINUS STROBUS	EASTERN WHITE PINE	2	4-5' HT.
AC	ABIES CONCOLOR	WHITE FIR	2	5-6' HT.

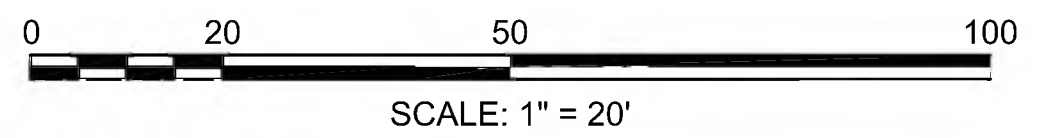
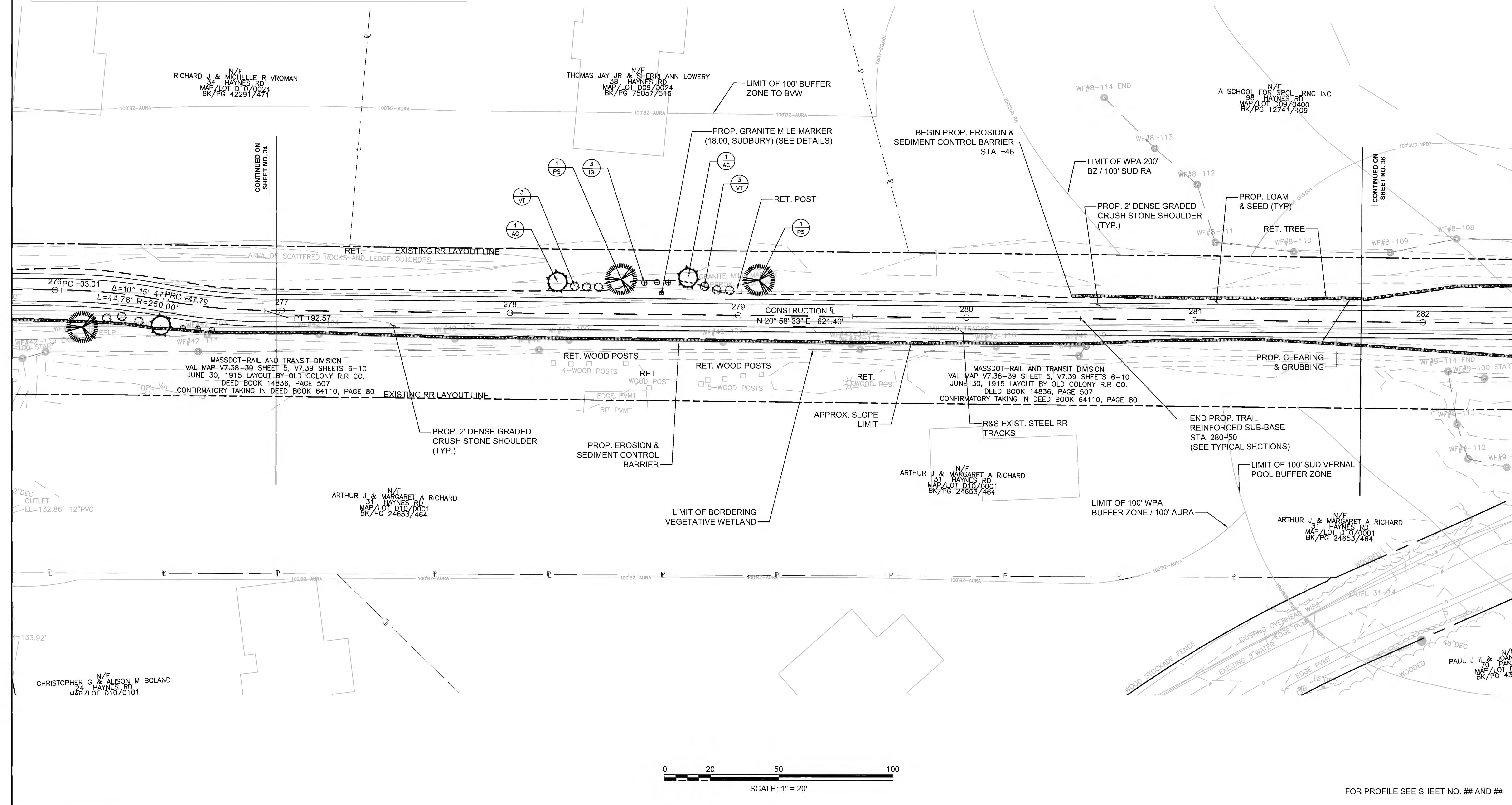
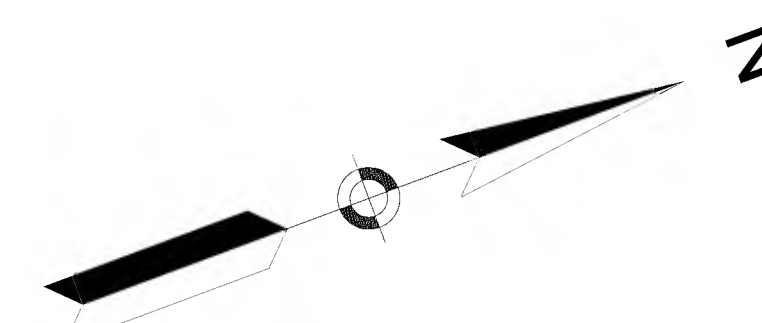

FOR PROFILE SEE SHEET NO. ## AND ##

FENCING DETAILS

TIMBER FENCE (THREE-RAIL) STA. 283+73 LT TO STA. 284+28 LT
 TIMBER FENCE (THREE-RAIL) STA. 284+65 RT TO STA. 291+25 RT

HIGHWAY GUARD DETAILS

STEEL W-BEAM GUARDRAIL (TL-2) W/ WOOD POST STA. 284+28 LT TO STA. 284+46 LT
 STEEL W-BEAM GUARDRAIL (TL-2) W/ WOOD POST STA. 284+75 LT TO STA. 285+18 LT
 STEEL W-BEAM GUARDRAIL (TL-2) W/ WOOD POST STA. 284+51 RT TO STA. 284+63 RT

TRAFFIC SIGNAL CONDUIT

NONE

WATER SUPPLY ALTERATIONS

NONE

DRAINAGE DETAILS

NONE

LEGEND:

PROPOSED WHEELCHAIR RAMP DETAIL #
 PLANT QUANTITY AND SPECIES

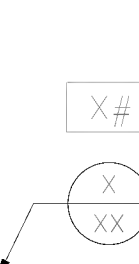

SUDBURY
BRUCE FREEMAN RAIL TRAIL

STATE	FED. AID PROJ. NO.	SHEET NO.	TOTAL SHEETS
MA	XXX-XXXX(XXX)X	36	319
PROJECT FILE NO.		608164	

CONSTRUCTION PLANS

PLANT LIST

KEY	BOTANICAL NAME	COMMON NAME	QTY.	SIZE
	ORNAMENTAL MIX			
CCR	CERCIS CANADENSIS	REDBUD	3	2-3" CAL.
HA	HYDRANGEA ARBORESCENS	SMOOTH HYDRANGEA	4	3 CAL.

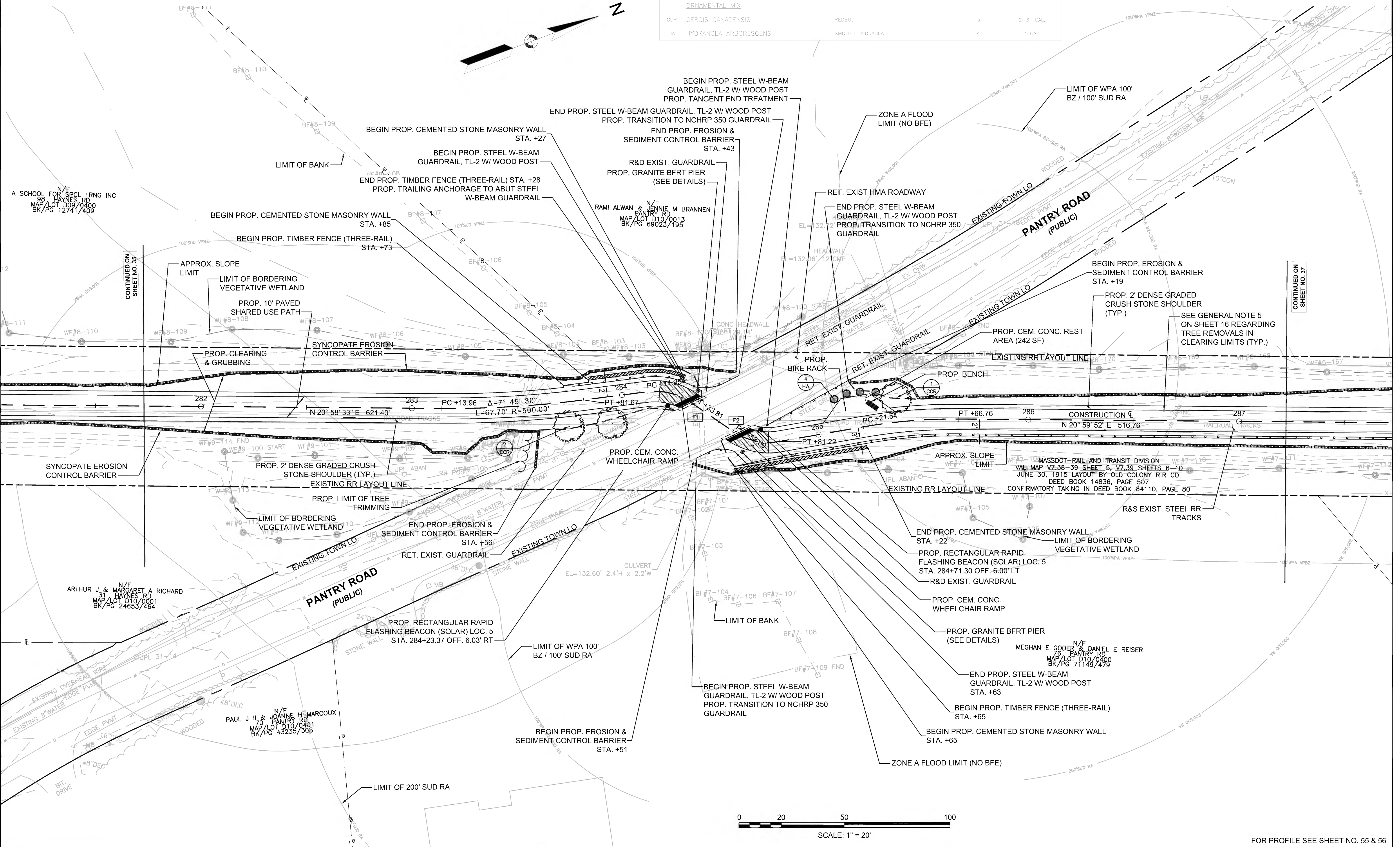

FOR PROFILE SEE SHEET NO. 55 & 56

FENCING DETAILS

TIMBER FENCE (THREE-RAIL) STA. 284+68 RT TO STA. 288+00 RT
TIMBER FENCE (THREE-RAIL) STA. 284+65 RT TO STA. 290+25 RT

HIGHWAY GUARD DETAILS

NONE

TRAFFIC SIGNAL CONDUIT

NONE

WATER SUPPLY ALTERATIONS

NONE

DRAINAGE DETAILS

NONE

LEGEND:

PROPOSED WHEELCHAIR RAMP DETAIL # X#

SUDBURY BRUCE FREEMAN RAIL TRAIL			
STATE	FED. AID PROJ. NO.	SHEET NO.	TOTAL SHEETS
MA	XXX-XXXX(XXX)X	37	319
PROJECT FILE NO.		608164	
CONSTRUCTION PLANS			

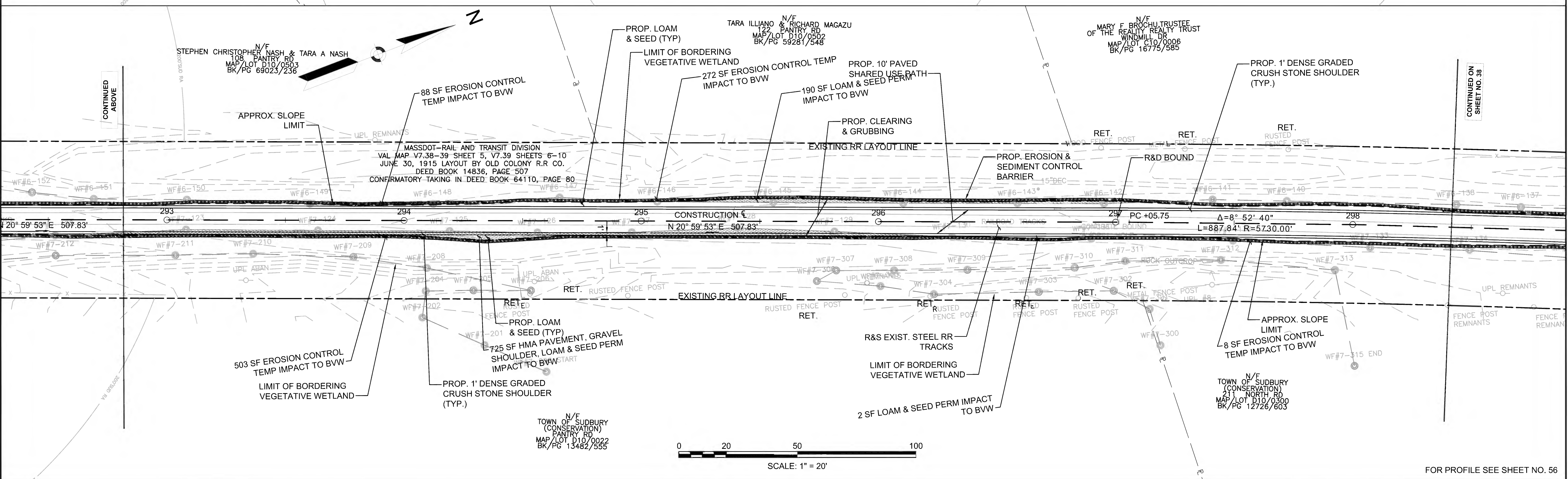
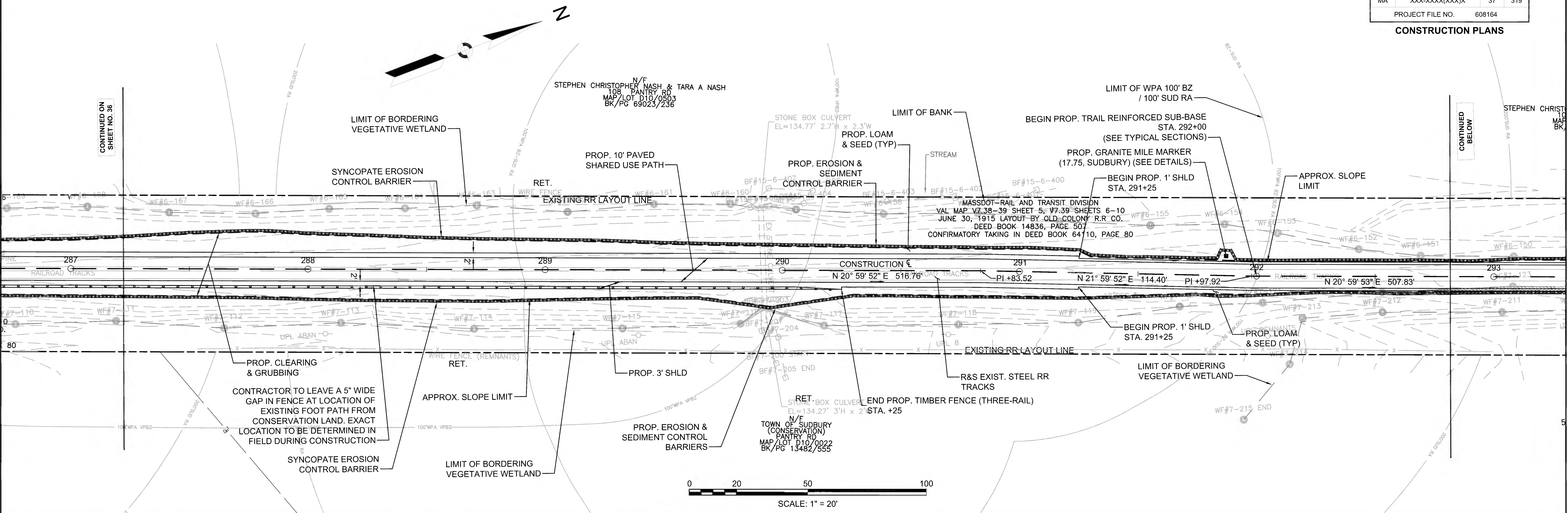

FOR PROFILE SEE SHEET NO. 56

608164_HDCONSTRUCTION PLANS.DWG Plotted on 18-Feb-2022 9:12 PM

FENCING DETAILS

TIMBER FENCE (THREE-RAIL) STA. 308+79 LT TO STA. 309+79 LT
TIMBER FENCE (THREE-RAIL) STA. 308+16 RT TO STA. 315+79 RT

HIGHWAY GUARD DETAILS

NONE

TRAFFIC SIGNAL CONDUIT

SEE SHEET ###

WATER SUPPLY ALTERATIONS

NONE

DRAINAGE DETAILS

SEE SHEET 197

LEGEND:

PROPOSED WHEELCHAIR RAMP DETAIL #

PLANT QUANTITY AND SPECIES

X#

X

SUDBURY
BRUCE FREEMAN RAIL TRAIL

STATE	FED. AID PROJ. NO.	SHEET NO.	TOTAL SHEETS
MA	XXX-XXXX(XXX)X	39	319
PROJECT FILE NO.		608164	

CONSTRUCTION PLANS

PLANT LIST

KEY	BOTANICAL NAME	COMMON NAME	QTY.	SIZE
VISUAL SCREEN MIX				
JV	JUNIPERUS VIRGINIANA	EASTERN RED CEDAR	4	4-5' HT.
VT	VILBURUM TRILOBUM	HIGHBUSH CRANBERRY	6	3 GAL.
IG	ILEX GLABRA	INKBERRY	3	3 GAL.
ORNAMENTAL MIX				
ACS	AMELANCHIER	CANADENSIS	1	2-3" CAL.
HA	HYDRANCA ARBORESCENS	SMOOTH HYDRANGEA	4	3 GAL.

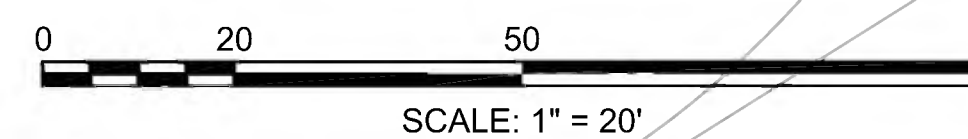
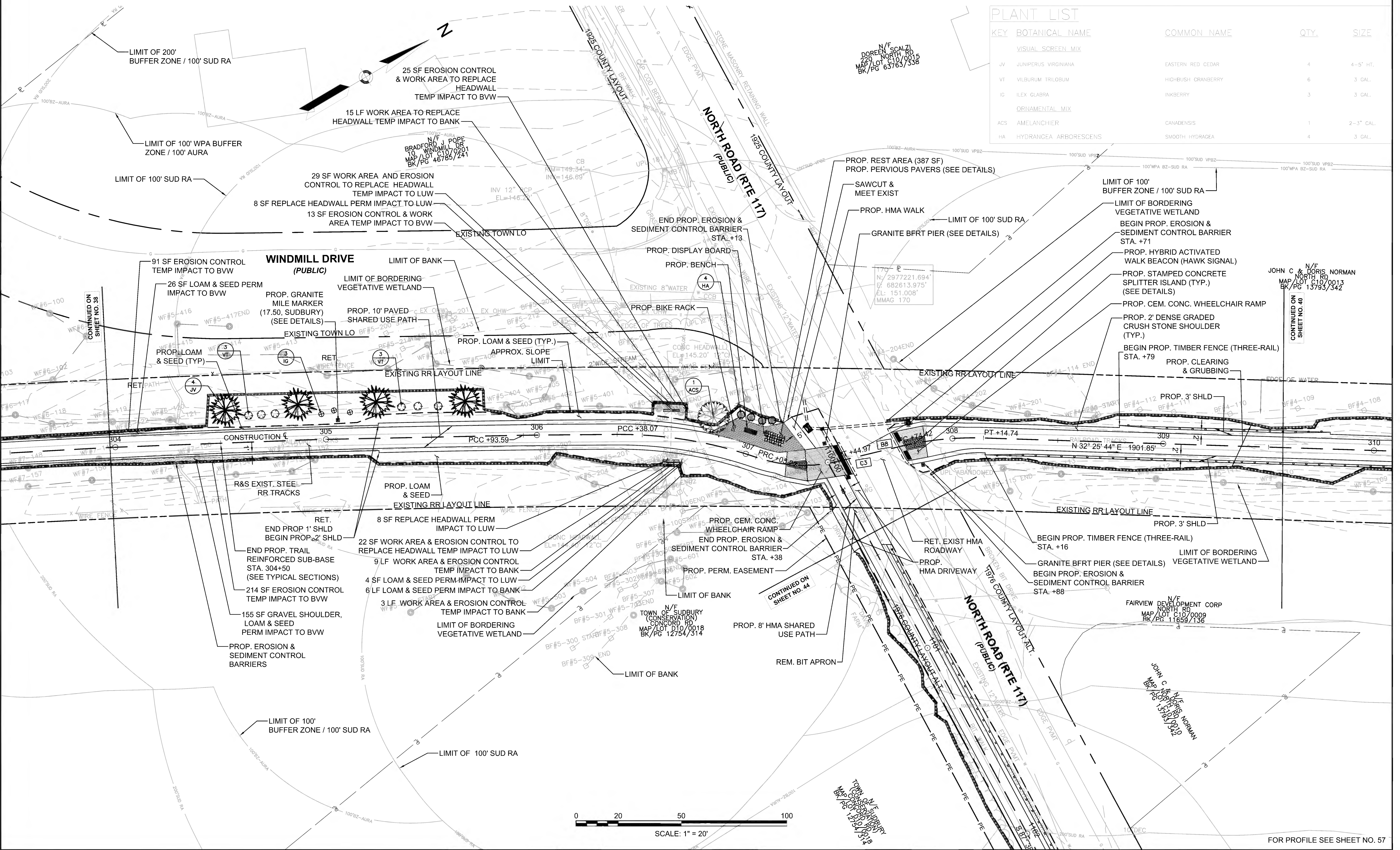

FOR PROFILE SEE SHEET NO. 57

608164 - HD(CONSTRUCTION PLANS).DWG Plotted on 18-Feb-2022 9:12 PM

FENCING DETAILS

TIMBER FENCE (THREE-RAIL) STA. 308+79 LT TO STA. 309+79 LT
 TIMBER FENCE (THREE-RAIL) STA. 313+29 LT TO STA. 316+29 LT
 TIMBER FENCE (THREE-RAIL) STA. 308+16 RT TO STA. 315+79 RT

HIGHWAY GUARD DETAILS

NONE

TRAFFIC SIGNAL CONDUIT

NONE

WATER SUPPLY ALTERATIONS

NONE

DRAINAGE DETAILS

NONE

LEGEND:
 PROPOSED WHEELCHAIR RAMP DETAIL # [Symbol]
 PLANT QUANTITY AND SPECIES [Symbol]

PLANT LIST

KEY	BOTANICAL NAME	COMMON NAME	QTY.	SIZE
VT	VILBURUM TRILOBUM	HIGHBUSH CRANBERRY	9	3 GAL.
IG	ILEX GLABRA	INKBERRY	9	3 GAL.
PS	PINUS STROBUS	EASTERN WHITE PINE	4	4-5' HT.
AC	ABIES CONCOLOR	WHITE FIR	3	5-6' HT.
SS	CAREX STRICTA	TUSsock SEDGE	24	PLUG
CS	CORNUS SERICEA & SALIX SSP	DOGWOOD AND WILLOW	18	1 GAL.
CCR	CERCIS CANADENSIS	REDBUD	3	2-3" CAL.
EROSION CONTROL MIX				
ORNAMENTAL MIX				

SUDBURY BRUCE FREEMAN RAIL TRAIL

STATE	FED. AID PROJ. NO.	SHEET NO.	TOTAL SHEETS
MA	XXX-XXXX(XXX)X	40	319

PROJECT FILE NO. 608164

CONSTRUCTION PLANS

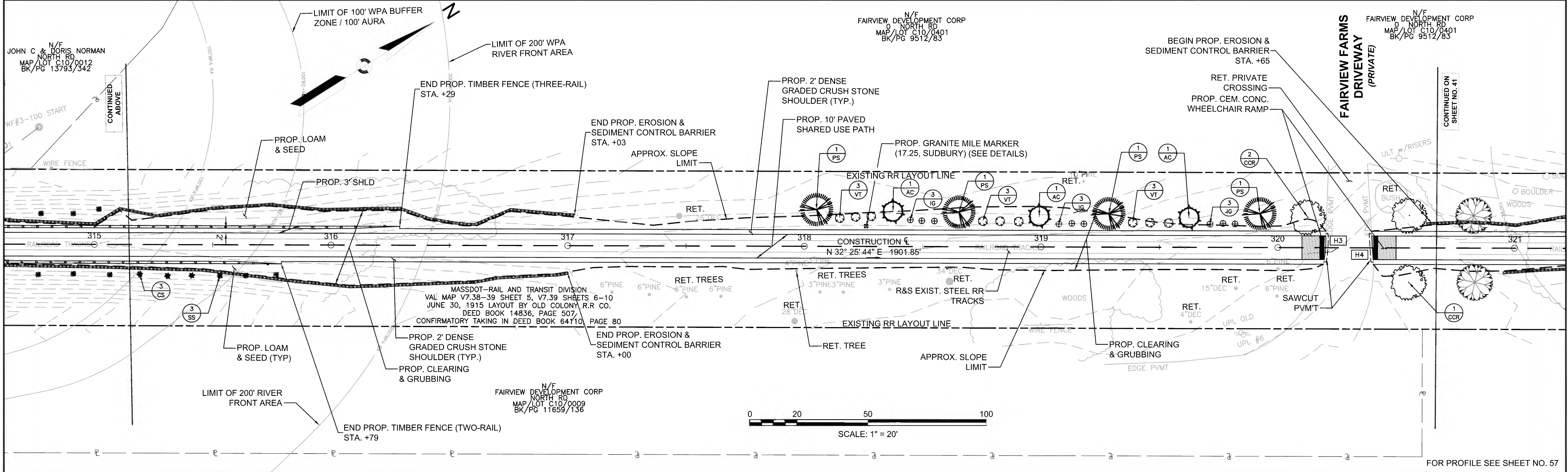
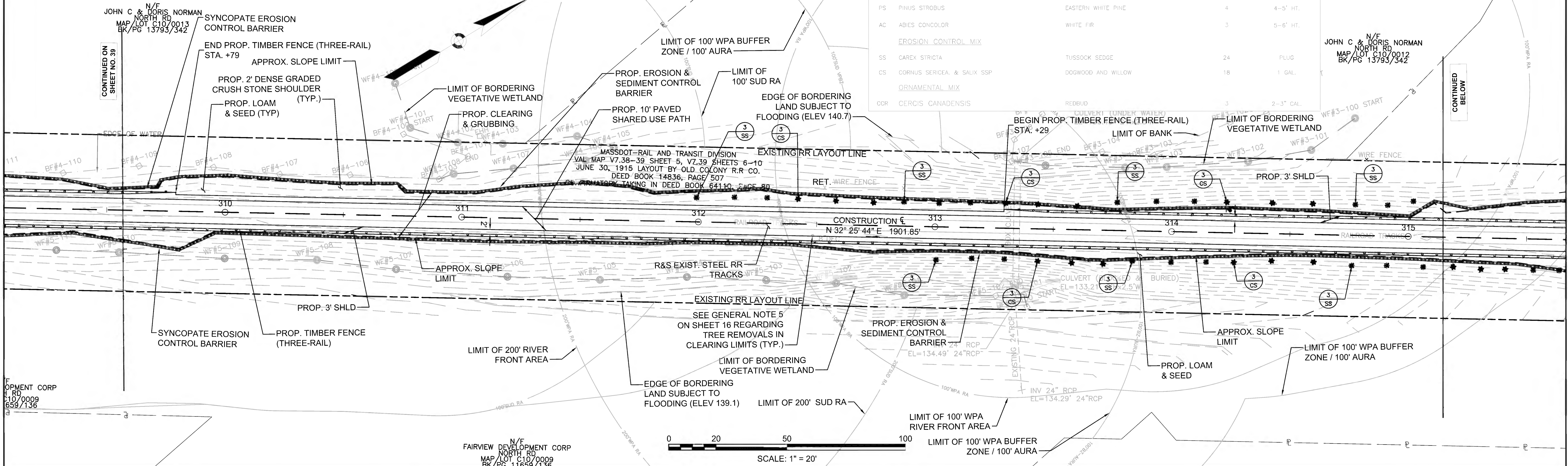

FENCING DETAILS

TIMBER FENCE (THREE-RAIL) STA. 332+16 LT TO STA. 333+11 LT

HIGHWAY GUARD DETAILS

NONE

TRAFFIC SIGNAL CONDUIT

NONE

WATER SUPPLY ALTERATIONS

NONE

DRAINAGE DETAILS

NONE

PLANT LIST

KEY	BOTANICAL NAME	COMMON NAME	QTY.	SIZE
	ORNAMENTAL MIX			
CCR	CERCIS CANADENSIS	REDBUD	2	2-3" CAL.
HA	HYDRANGEA ARBORESCENS	SMOOTH HYDRAGEA	5	3 CAL.

LEGEND:

PROPOSED WHEELCHAIR RAMP DETAIL #

X#

PLANT QUANTITY AND SPECIES

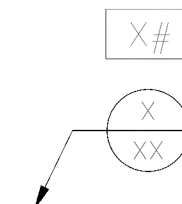

SUDBURY BRUCE FREEMAN RAIL TRAIL

STATE	FED. AID PROJ. NO.	SHEET NO.	TOTAL SHEETS
MA	XXX-XXXX(XXX)X	42	319

PROJECT FILE NO. 608164

CONSTRUCTION PLANS

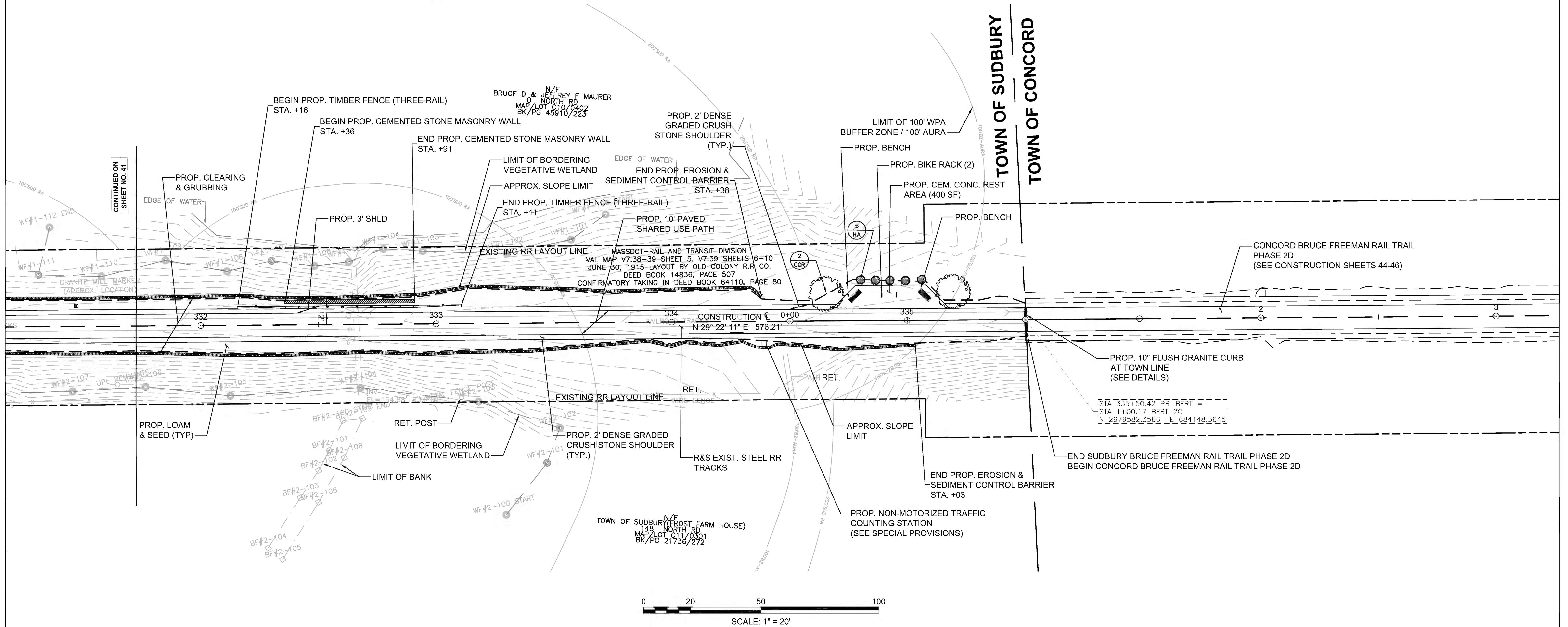

FENCING DETAILS NONE
 HIGHWAY GUARD DETAILS NONE
 TRAFFIC SIGNAL CONDUIT NONE
 WATER SUPPLY ALTERATIONS NONE
 DRAINAGE DETAILS NONE

PLANT LIST

KEY	BOTANICAL NAME	COMMON NAME	QTY.	SIZE
	ORNAMENTAL MIX			
CCR	CERCIS CANADENSIS	REDBUD	5	2-3" CAL.
ACS	AMELANCHIER	CANADENSIS	4	2-3" CAL.
HA	HYDRANGEA ARBORESCENS	SMOOTH HYDRANGEA	5	3 GAL.

LEGEND:

PROPOSED WHEELCHAIR RAMP DETAIL #
 PLANT QUANTITY AND SPECIES

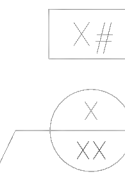

SUBURBY
BRUCE FREEMAN RAIL TRAIL

STATE	FED. AID PROJ. NO.	SHEET NO.	TOTAL SHEETS
MA	XXX-XXXX(XXX)X	43	319

PROJECT FILE NO. 608164
CONSTRUCTION PLANS

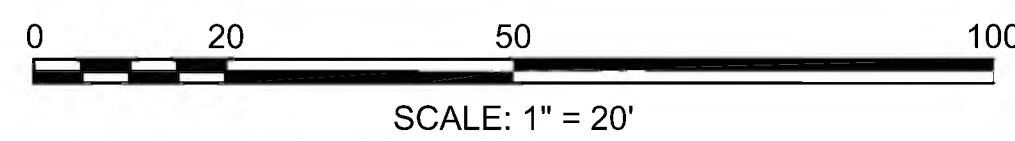
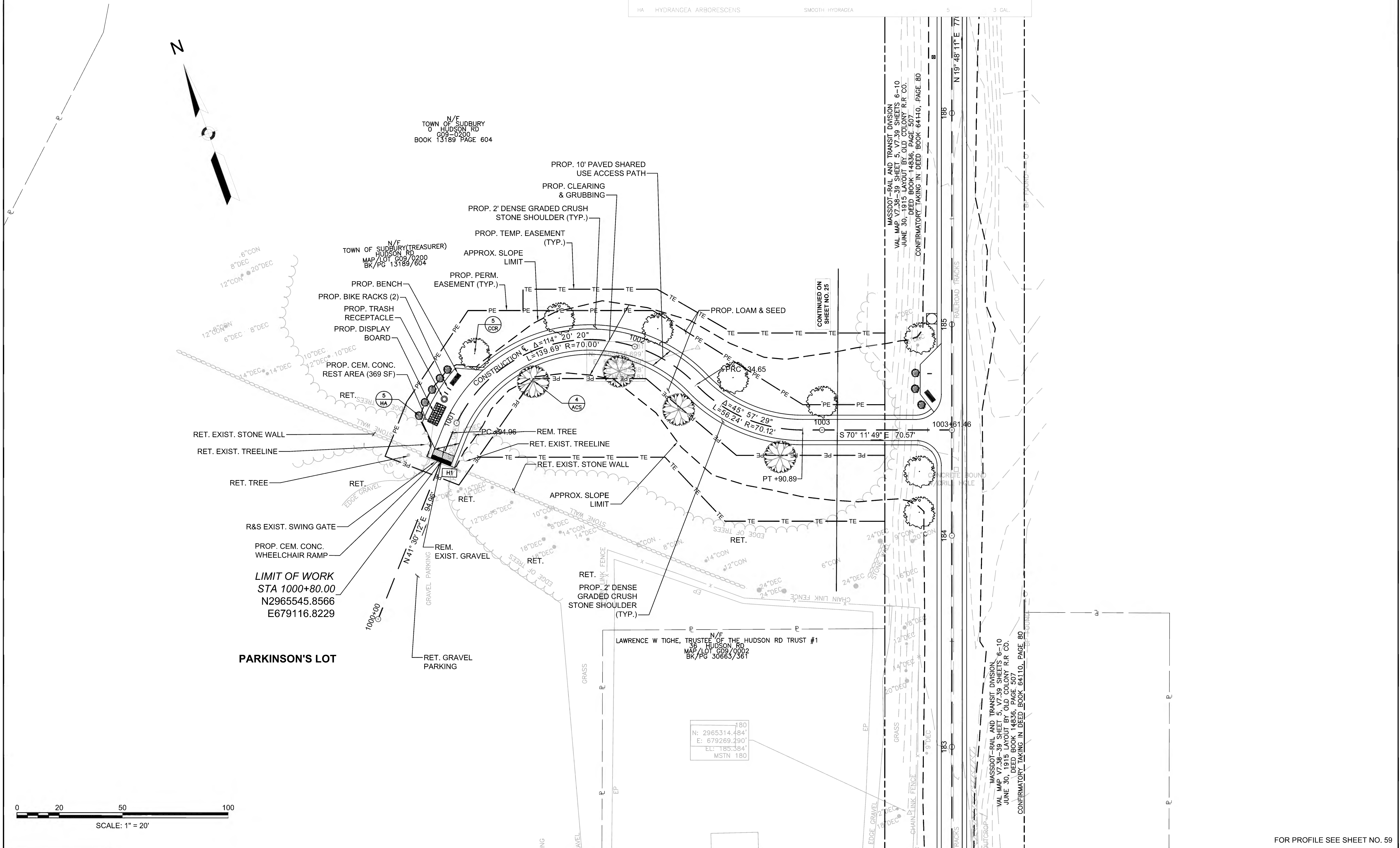

N: 2965314.484'
 E: 679269.290'
 EL: 185.384'
 MSTN 180

MASSDOT-RAIL AND TRANSIT DIVISION
 VAL MAP V7.38-39 SHEET 5, V7.39 SHEETS 6-10
 JUNE 30, 1915 LAYOUT BY OLD COLONY R.R. CO.
 DEED BOOK 14836, PAGE 507
 CONFIRMATORY TAKING IN DEED BOOK 64110, PAGE 80

FOR PROFILE SEE SHEET NO. 59

FENCING DETAILS

TIMBER FENCE (THREE-RAIL) STA. 1102+10 RT TO STA. 1103+20 RT

HIGHWAY GUARD DETAILS

STEEL W-BEAM (TL-2) W/WOOD POST & RUB RAIL
STA. 1100+51 LT TO STA. 1105+84 LT
TIMBER GUARDRAIL W/ RUB RAIL
STA. 1106+00 LT TO STA. 1107+27 LT

TRAFFIC SIGNAL CONDUIT

NONE

WATER SUPPLY ALTERATIONS

SEE SHEET 202

DRAINAGE DETAILS

SEE SHEET 202

LEGEND:

PROPOSED WHEELCHAIR RAMP DETAIL #

X#

BRUCE FREEMAN RAIL TRAIL			
STATE	FED. AID PROJ. NO.	SHEET NO.	TOTAL SHEETS
MA	XXX-XXXX(XXX)X	44	319
PROJECT FILE NO.		608164	
CONSTRUCTION PLANS			

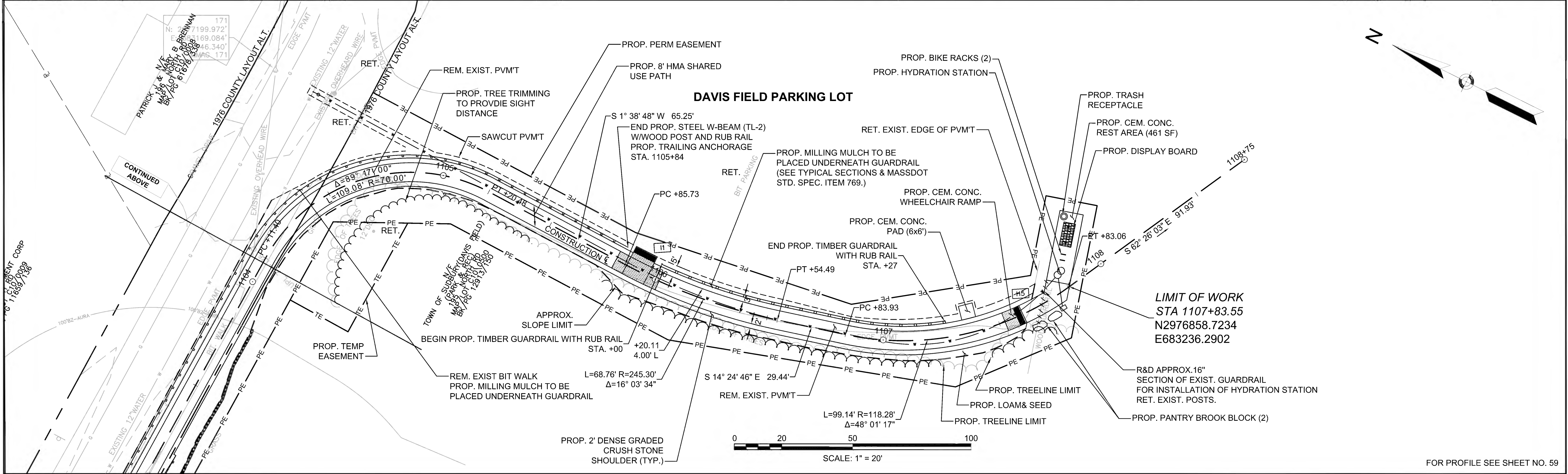
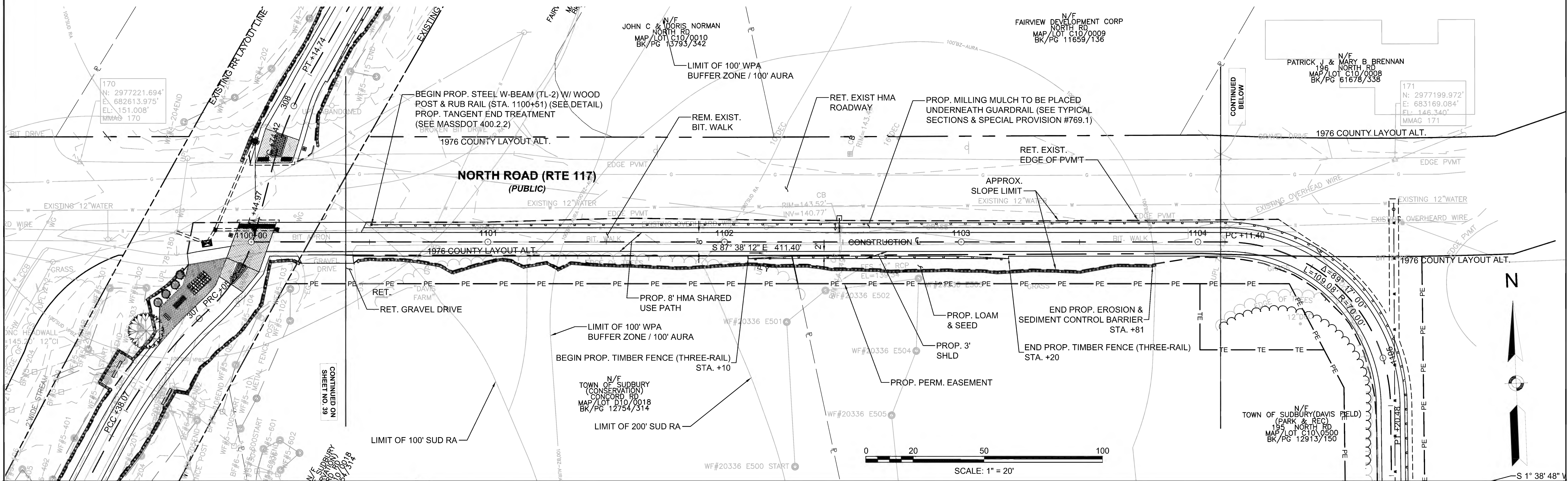

608164 - HD(CONSTRUCTION PLANS).DWG Plotted on 18-Feb-2022 9:14 PM

FOR PROFILE SEE SHEET NO. 59

SUDBURY BRUCE FREEMAN RAIL TRAIL			
STATE	FED. AID PROJ. NO.	SHEET NO.	TOTAL SHEETS
MA	XXX-XXXX(XXX)X	48	319
PROJECT FILE NO.		608164	

PROFILES

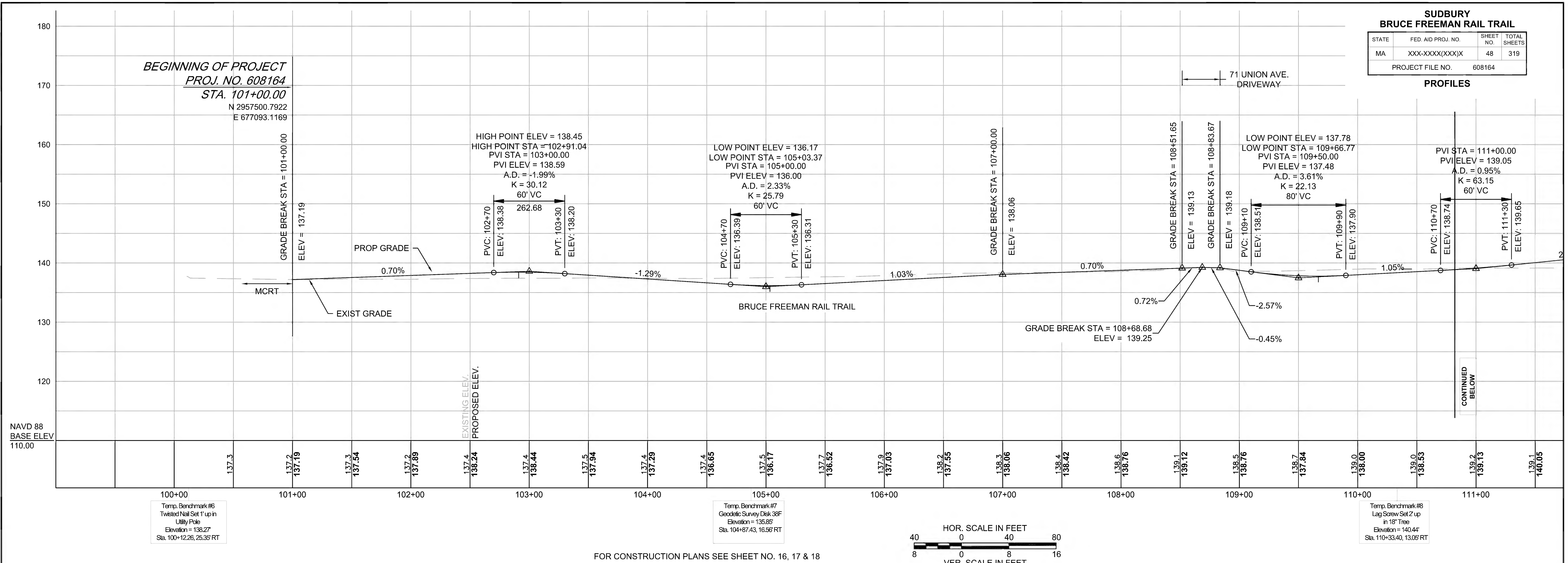

Temp. Benchmark #6
Twisted Nail Set 1" up in
Utility Pole
Elevation = 138.27
Sta. 100+12.26, 25.35 RT

Temp. Benchmark #7
Geodetic Survey Disk 38F
Elevation = 136.85
Sta. 104+97.43, 16.56 RT

Temp. Benchmark #8
Lag Screw Set 2" up in 18" Tree
Elevation = 140.44
Sta. 110+33.40, 13.05 RT

FOR CONSTRUCTION PLANS SEE SHEET NO. 16, 17 & 18

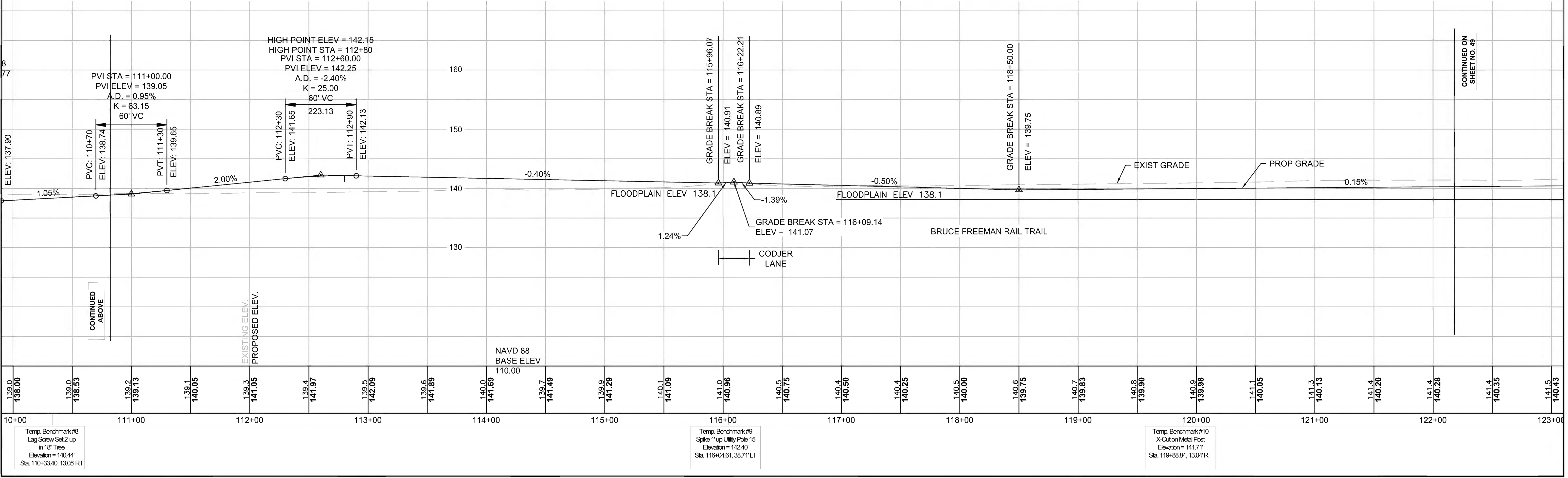

Temp. Benchmark #8
Lag Screw Set 2" up in 18" Tree
Elevation = 140.44
Sta. 110+33.40, 13.05 RT

Temp. Benchmark #9
Spike 1" up Utility Pole 15
Elevation = 142.40
Sta. 116+04.61, 38.71 LT

Temp. Benchmark #10
X-Cut on Metal Post
Elevation = 141.71
Sta. 119+88.84, 13.04 RT

SUDBURY BRUCE FREEMAN RAIL TRAIL			
STATE	FED. AID PROJ. NO.	SHEET NO.	TOTAL SHEETS
MA	XXX-XXXX(XXX)X	49	319
PROJECT FILE NO.		608164	

PROFILES

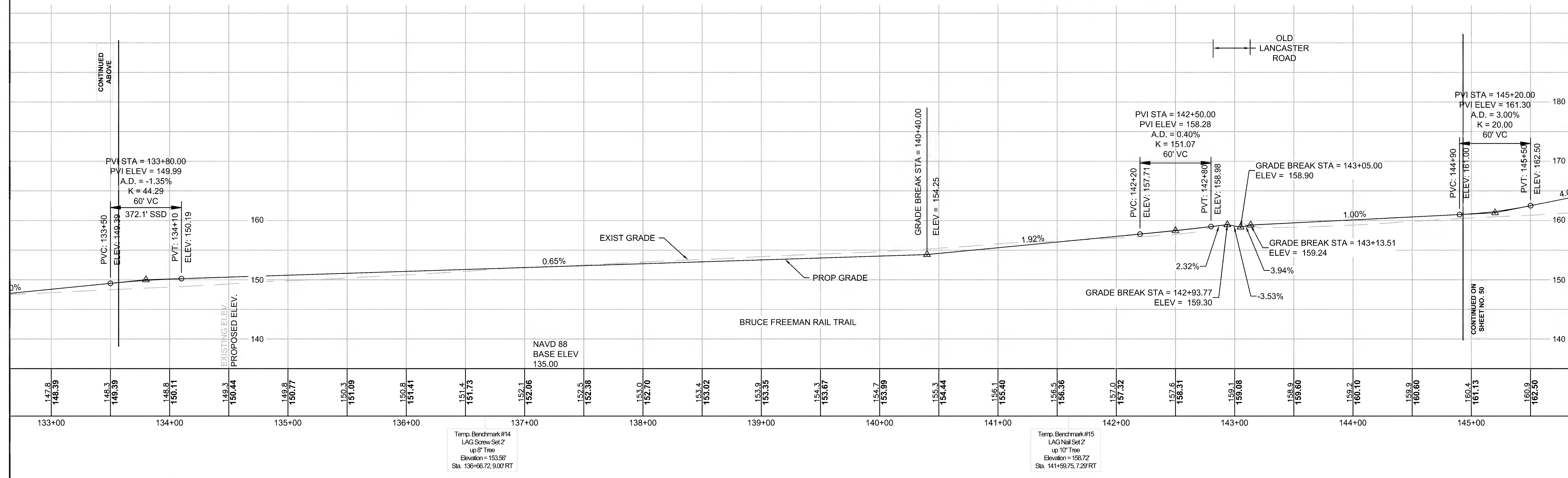
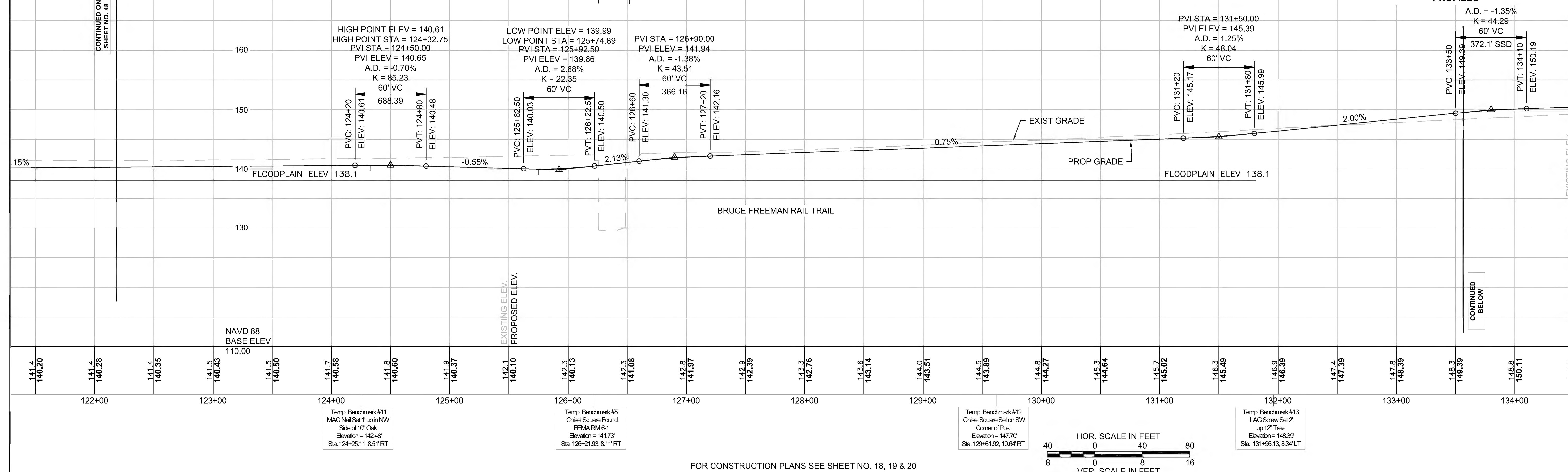

PROFILES

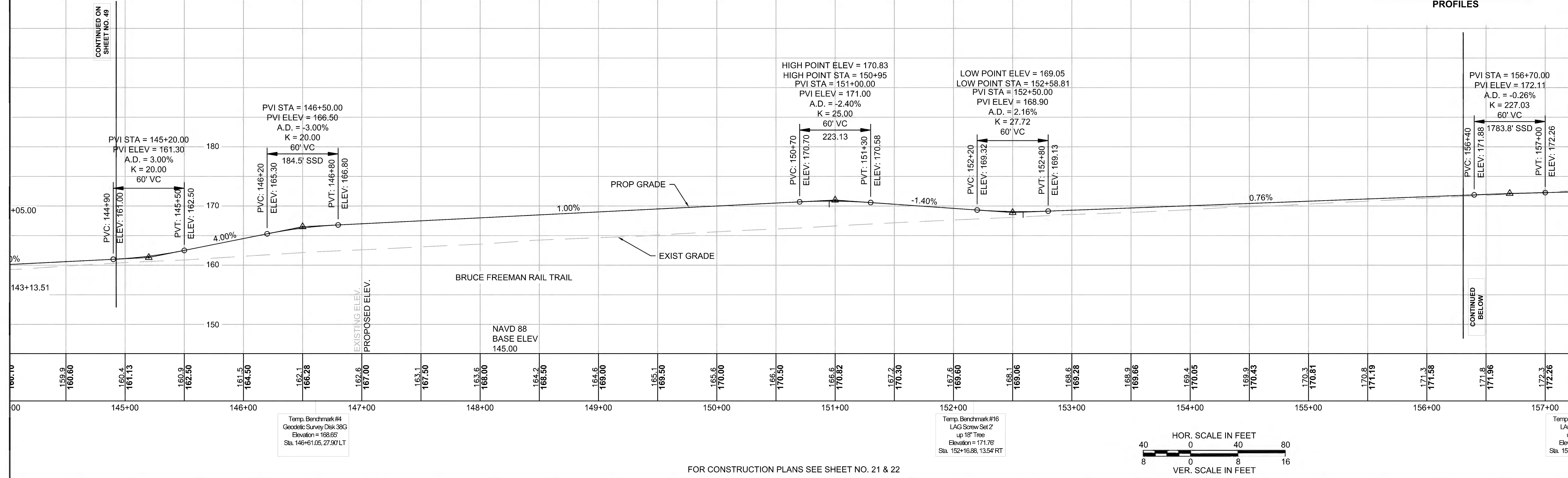

FOR CONSTRUCTION PLANS SEE SHEET NO. 21 & 22

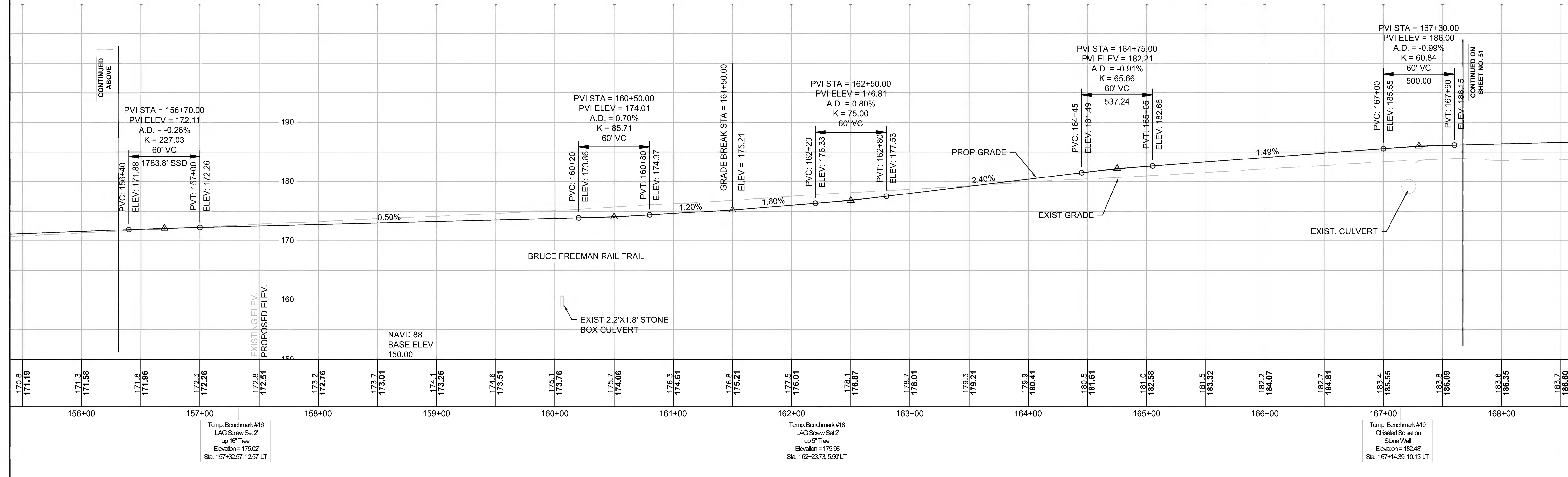
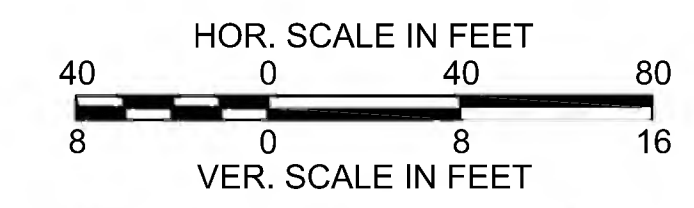

CONTINUED ON SHEET NO. 49

CONTINUED BELOW

CONTINUED ABOVE

CONTINUED ON SHEET NO. 51

Temp. Benchmark #4
Geodetic Survey Disk-38G
Benchmark = 168.85
Sta. 146+61.05, 27.90 LT

Temp. Benchmark #16
LAG Screw Set 2
up 16" Tree
Elevation = 171.76
Sta. 152+16.88, 13.54 RT

Temp. Benchmark #16
LAG Screw Set 2
up 16" Tree
Elevation = 175.02
Sta. 157+32.57, 12.57 LT

Temp. Benchmark #18
LAG Screw Set 2
up 5" Tree
Elevation = 179.98
Sta. 162+23.73, 5.50 LT

Temp. Benchmark #19
Chiseled Sq set on
Stone Wall
Elevation = 182.48
Sta. 167+14.39, 10.13 LT

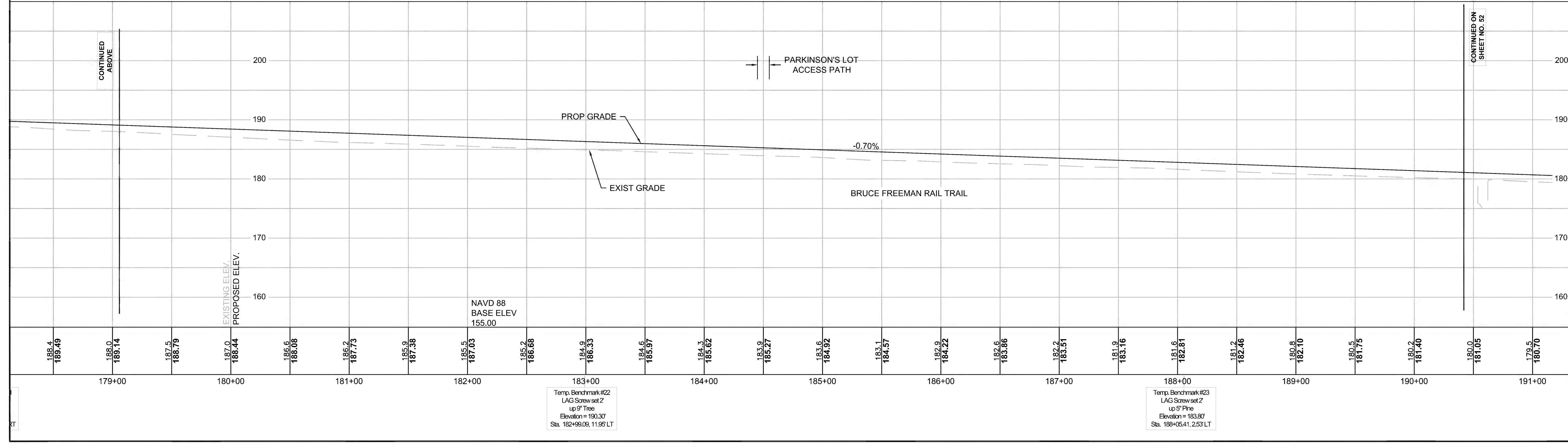
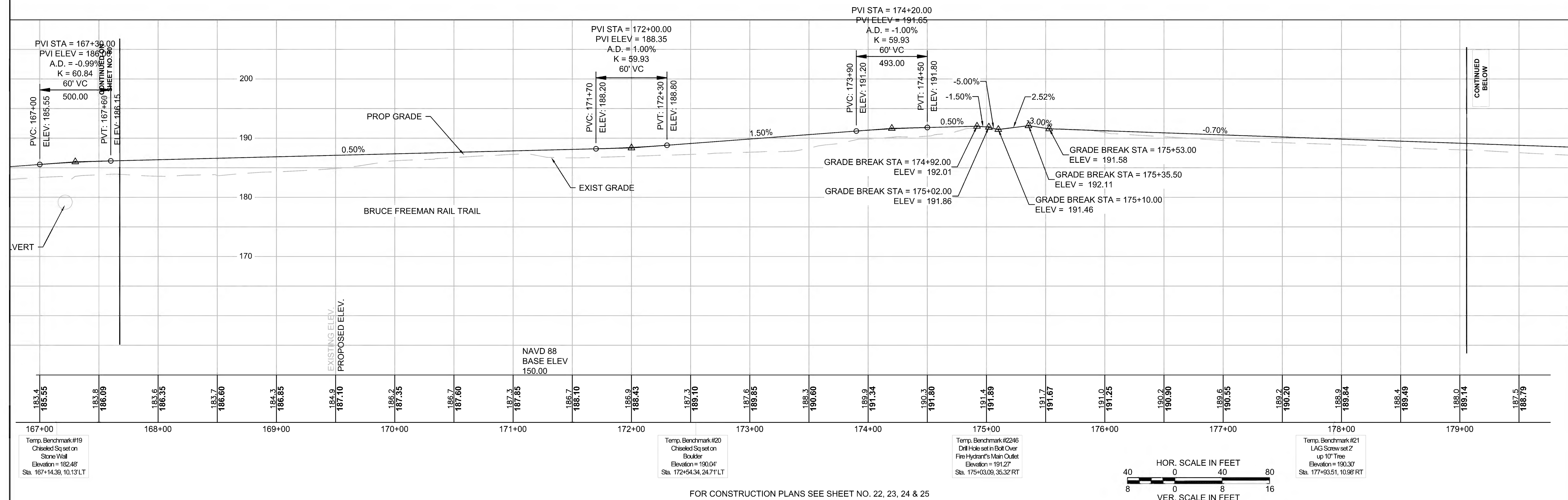

SUDBURY BRUCE FREEMAN RAIL TRAIL			
STATE	FED. AID PROJ. NO.	SHEET NO.	TOTAL SHEETS
MA	XXX-XXXX(XXX)X	52	319
PROJECT FILE NO.		608164	

PROFILES

HIGH POINT ELEV = 177.81
HIGH POINT STA = 201+88.21
PVI STA = 201+74.00
PVI ELEV = 177.92

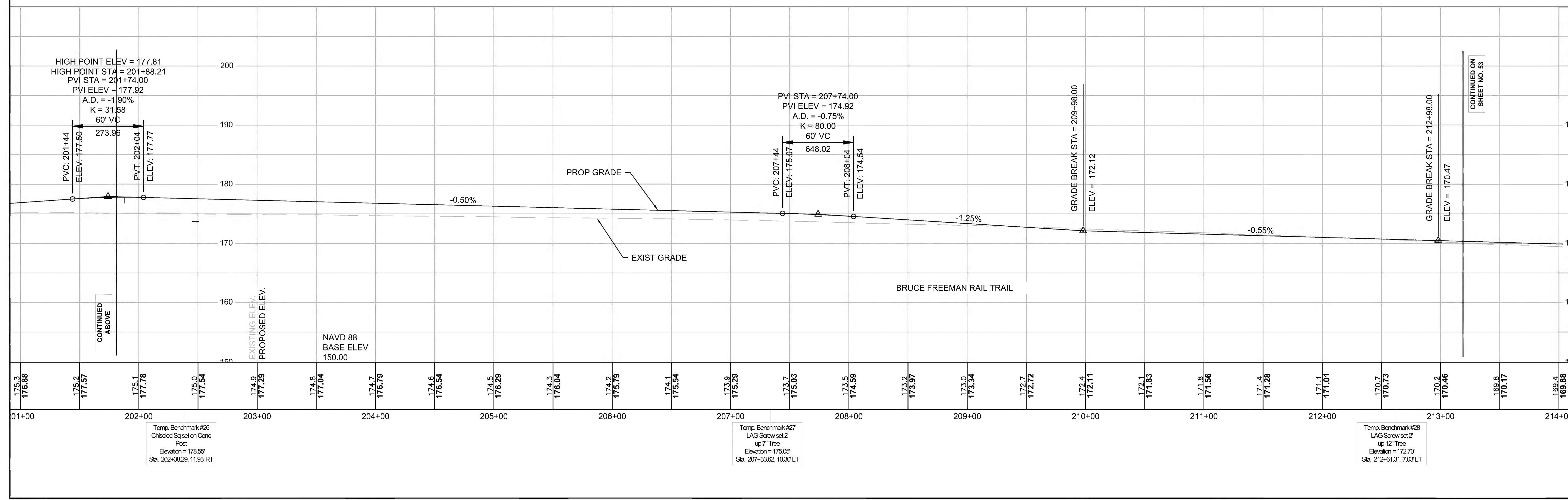
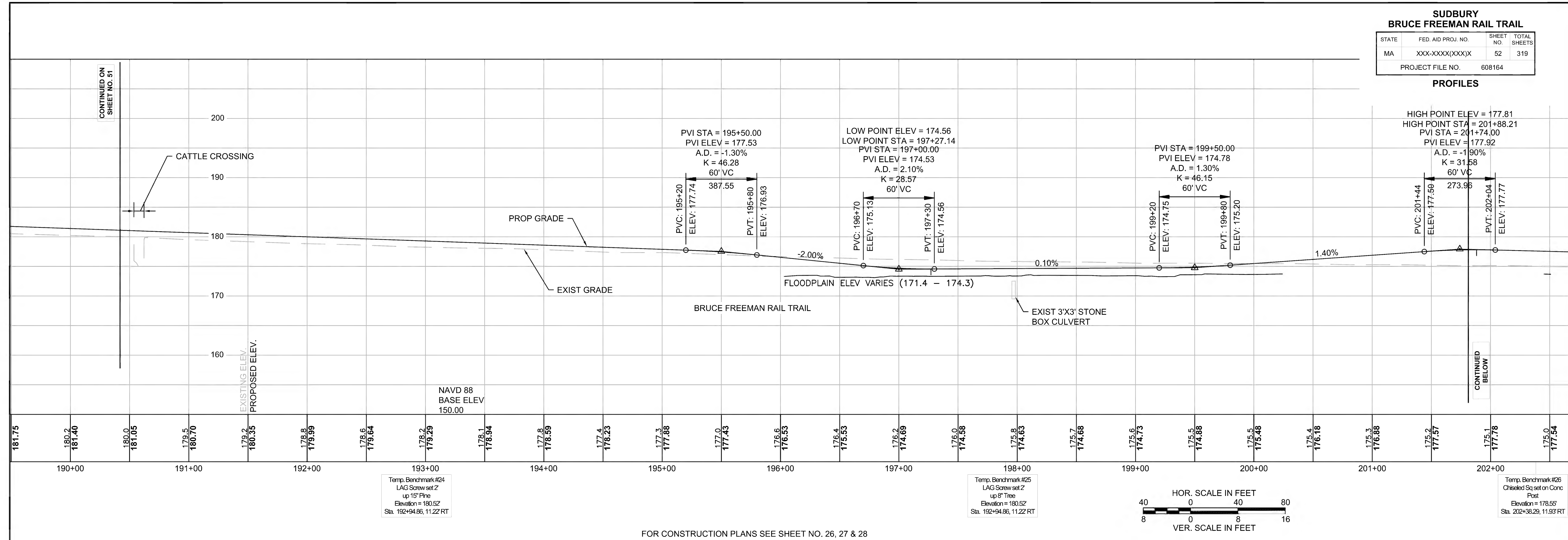

SUDBURY BRUCE FREEMAN RAIL TRAIL			
STATE	FED. AID PROJ. NO.	SHEET NO.	TOTAL SHEETS
MA	XXX-XXXX(XXX)X	53	319
PROJECT FILE NO.		608164	

PROFILES

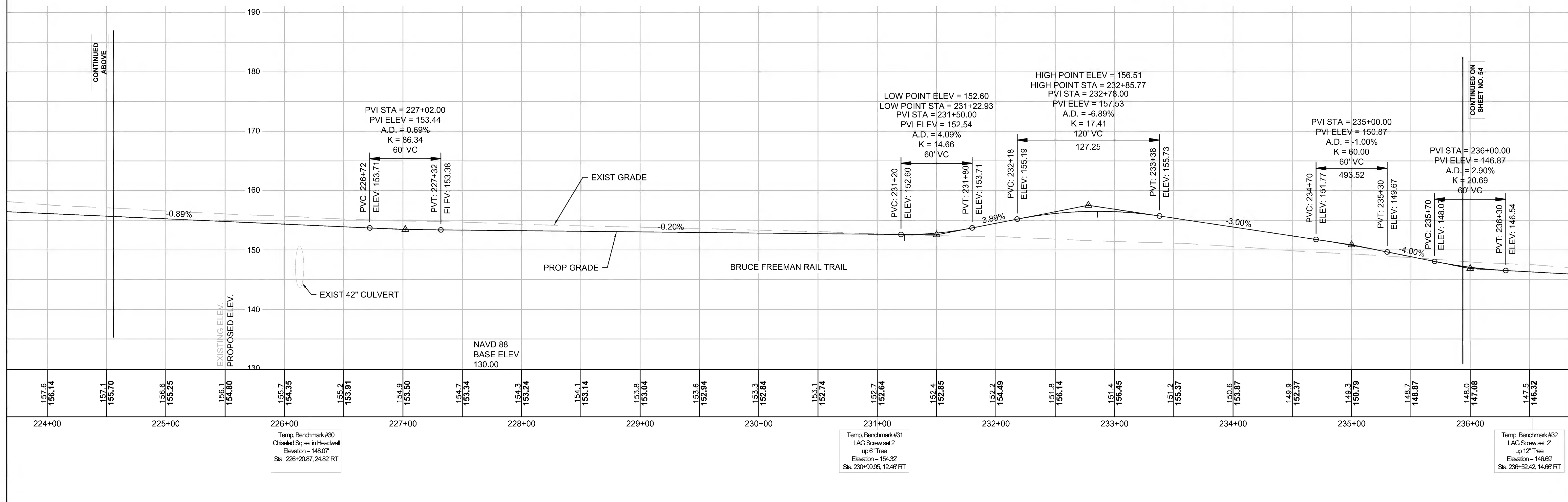
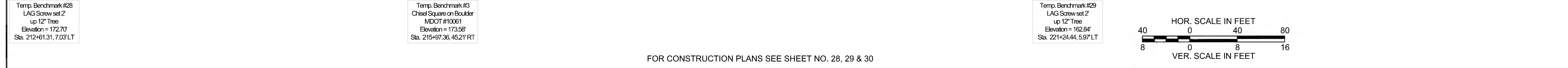
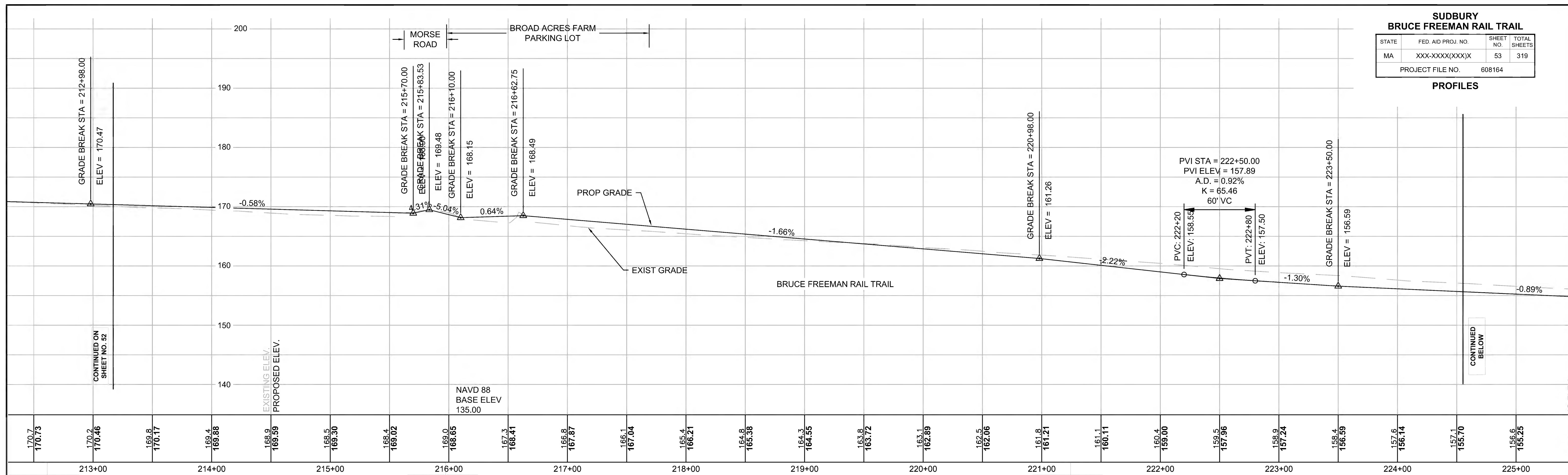

SUDBURY BRUCE FREEMAN RAIL TRAIL			
STATE	FED. AID PROJ. NO.	SHEET NO.	TOTAL SHEETS
MA	XXX-XXX(XXX)X	54	319
PROJECT FILE NO.		608164	

PROFILES

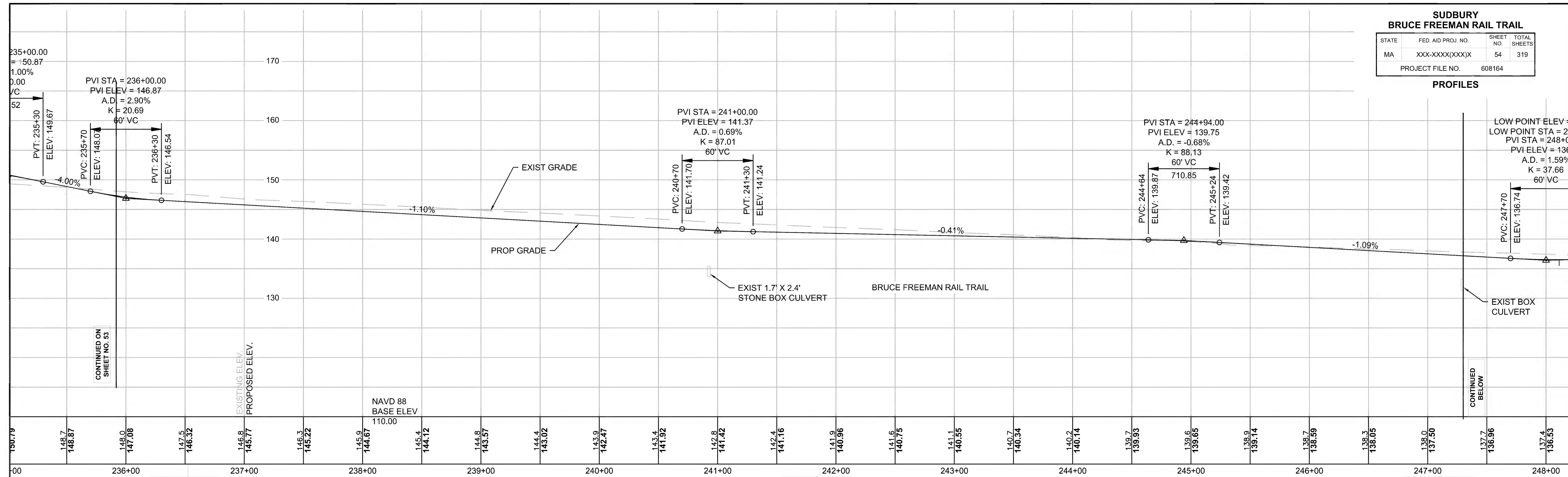

Temp. Benchmark #32
LAG Screw set Z
up 12" Tree
Elevation = 146.69'
Sta. 236+52.42, 14.66' RT

Temp. Benchmark #33
LAG Screw set Z
up 15" Tree
Elevation = 143.77'
Sta. 241+86.42, 8.50' RT

Temp. Benchmark #34
LAG Screw set Z
up 6" Tree
Elevation = 138.92'
Sta. 247+11.25, 9.50' LT

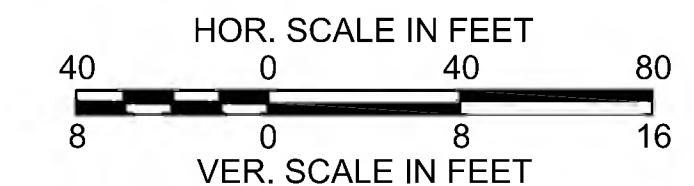

FOR CONSTRUCTION PLANS SEE SHEET NO. 30, 31 & 32

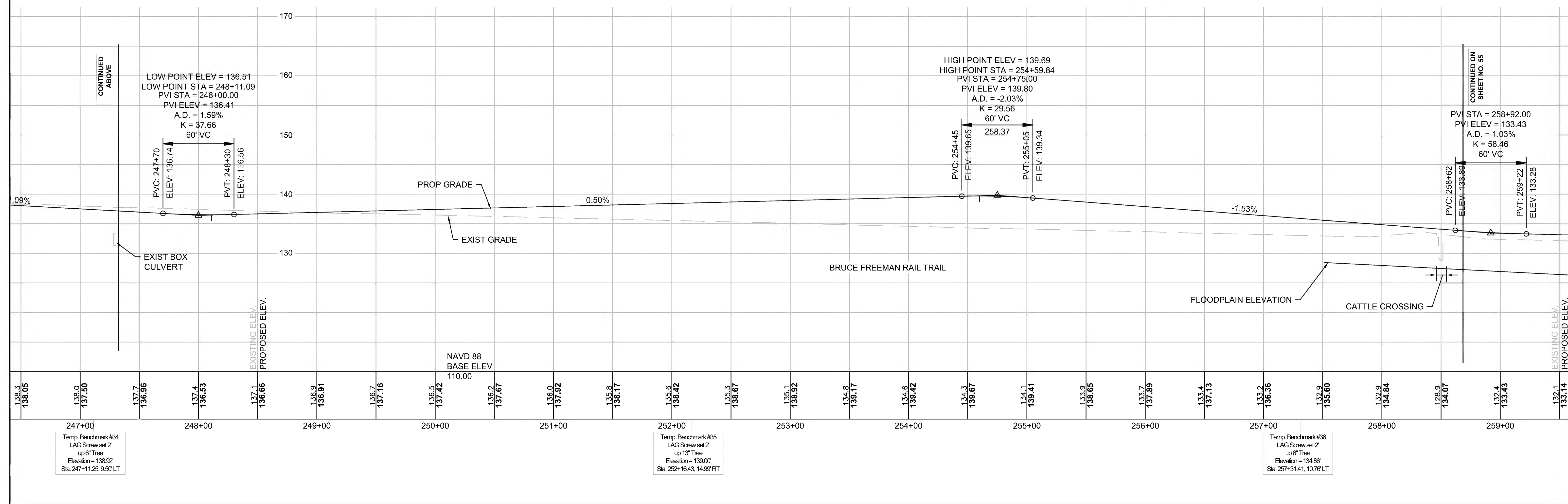

Temp. Benchmark #34
LAG Screw set Z
up 6" Tree
Elevation = 138.92'
Sta. 247+11.25, 9.50' LT

Temp. Benchmark #35
LAG Screw set Z
up 13" Tree
Elevation = 139.00'
Sta. 252+16.43, 14.99' RT

Temp. Benchmark #36
LAG Screw set Z
up 6" Tree
Elevation = 134.86'
Sta. 257+31.41, 10.76' LT

SUDBURY BRUCE FREEMAN RAIL TRAIL			
STATE	FED. AID PROJ. NO.	SHEET NO.	TOTAL SHEETS
MA	XXX-XXXX(XXX)X	55	319
PROJECT FILE NO.		608164	

PROFILES

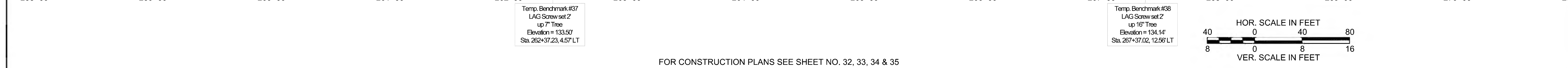
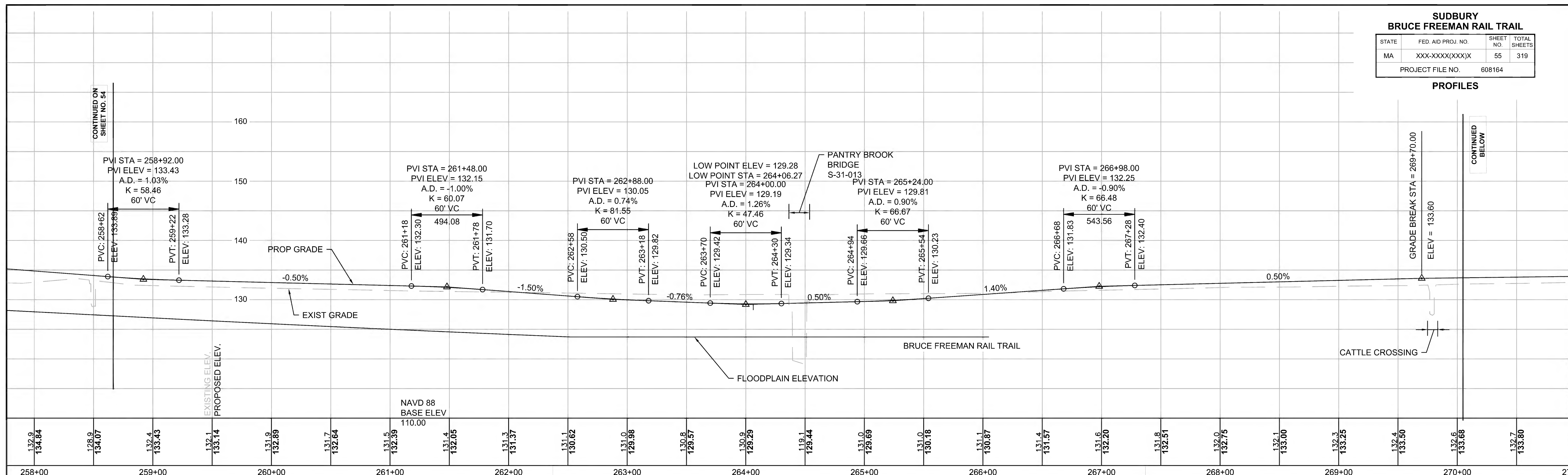

FOR CONSTRUCTION PLANS SEE SHEET NO. 32, 33, 34 & 35

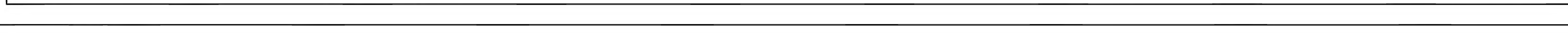
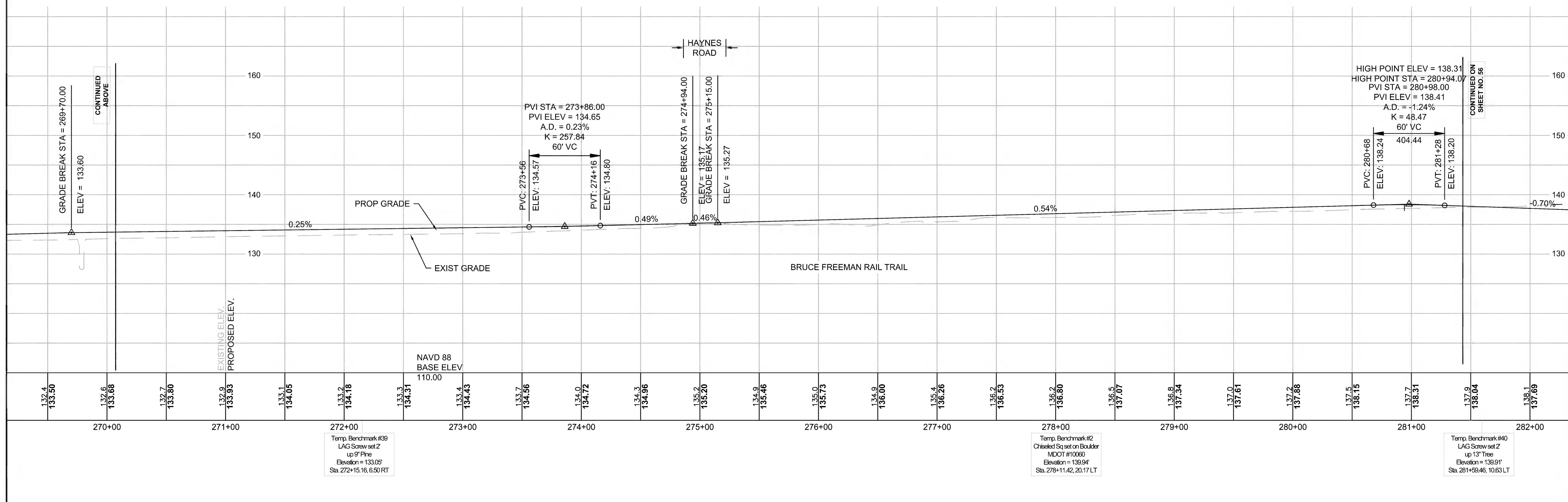
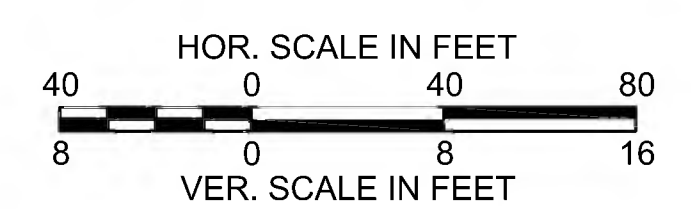

SUDBURY BRUCE FREEMAN RAIL TRAIL			
STATE	FED. AID PROJ. NO.	SHEET NO.	TOTAL SHEETS
MA	XXX-XXXX(XXX)X	56	319
PROJECT FILE NO.		608164	

PROFILES

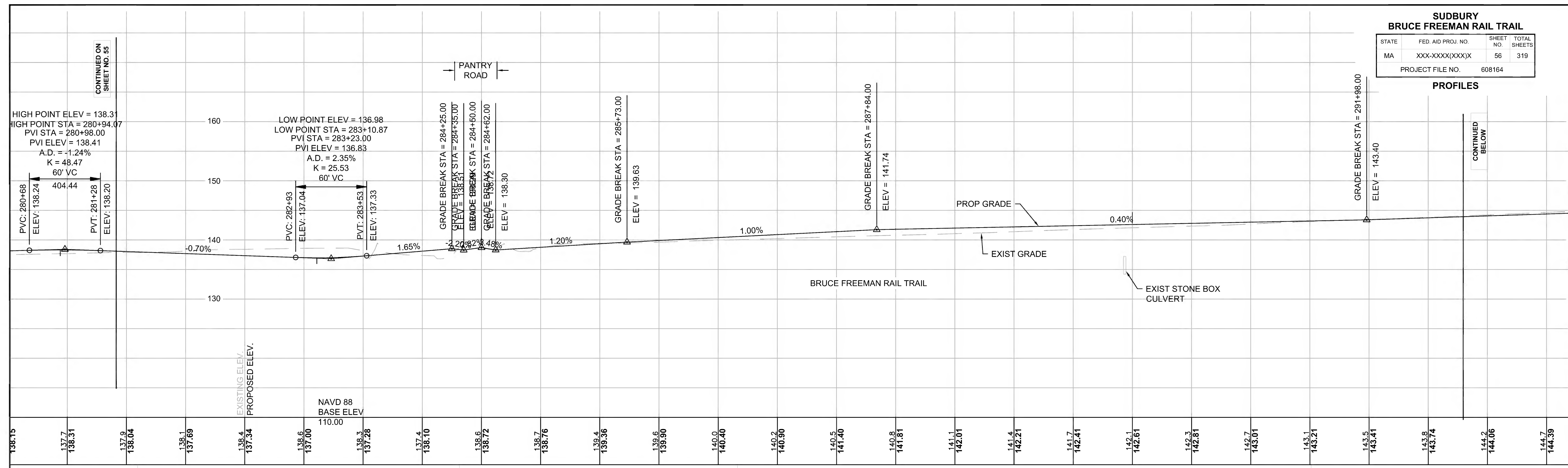

Temp. Benchmark #40
LAG Screw set 2"
up 15" Tree
Elevation = 139.91'
Sta. 281+59.46, 10.63 LT

Temp. Benchmark #1
Chisled Sq set on Headwall
ELEVATION = 133.07'
Sta. 284+31.45, 23.17 LT

Temp. Benchmark #11
LAG Screw set 2"
up 6" Tree
Elevation = 141.97'
Sta. 286+66.39, 4.89 LT

Temp. Benchmark #42
LAG Screw set
2" up 18" Tree
Elevation = 144.98'
Sta. 291+51.08, 8.37 RT

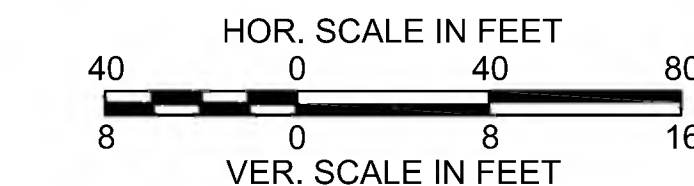

FOR CONSTRUCTION PLANS SEE SHEET NO. 35, 36, 37 & 38

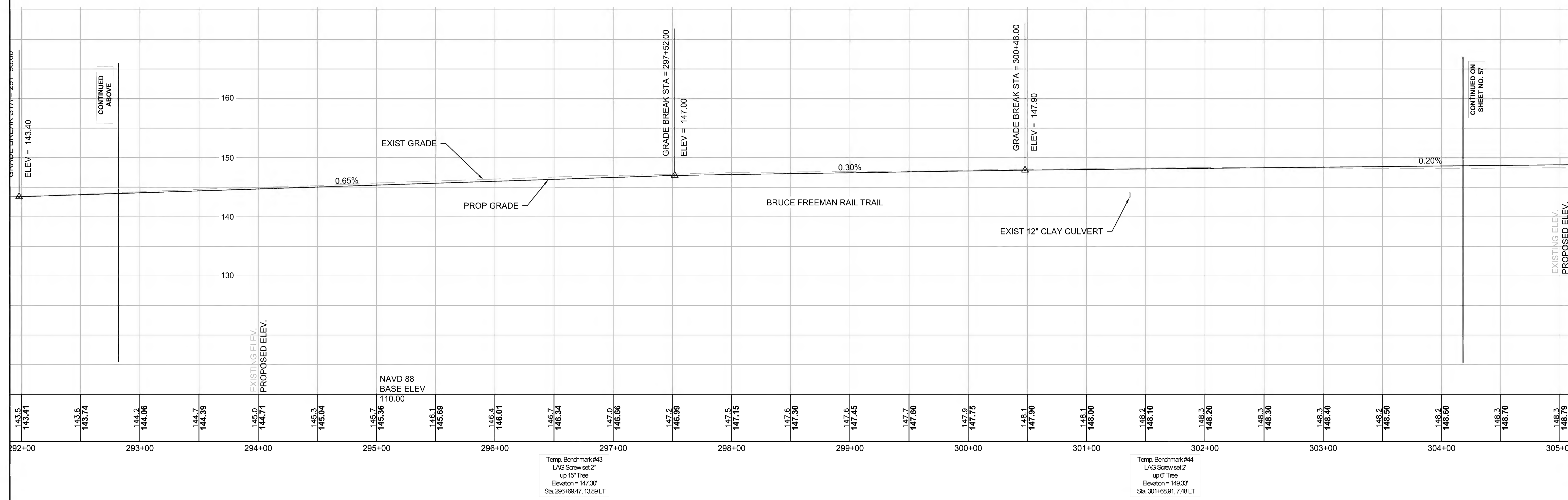

Temp. Benchmark #43
LAG Screw set 2"
up 15" Tree
Elevation = 147.30'
Sta. 296+69.47, 13.89 LT

Temp. Benchmark #44
LAG Screw set 2"
up 6" Tree
Elevation = 149.33'
Sta. 301+68.91, 7.48 LT

SUDBURY BRUCE FREEMAN RAIL TRAIL			
STATE	FED. AID PROJ. NO.	SHEET NO.	TOTAL SHEETS
MA	XXX-XXXX(XXX)X	57	319
PROJECT FILE NO.		608164	

PROFILES

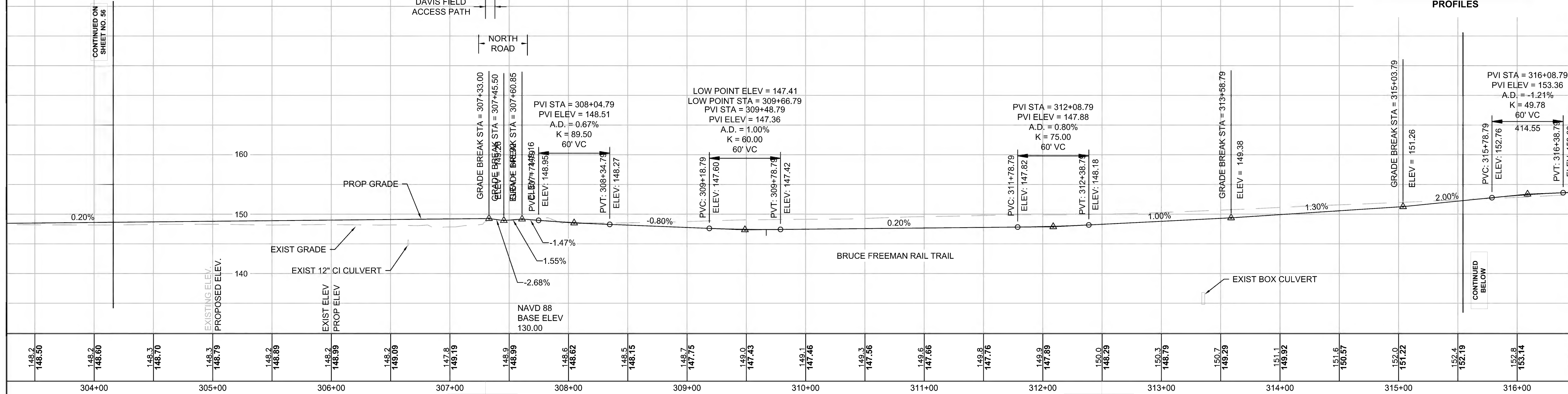

Station	Existing Elev.	Proposed Elev.
304+00	148.2	148.50
305+00	148.3	148.70
306+00	148.7	148.79
307+00	148.2	148.89
308+00	148.6	148.62
309+00	148.7	147.75
310+00	149.1	147.46
311+00	149.3	147.56
312+00	149.8	147.76
313+00	150.3	148.79
314+00	151.1	149.92
315+00	151.6	150.57
316+00	152.8	153.14

Temp. Benchmark #45
Nail set up 1' UPL 78/180
Elevation = 150.90
Sta. 307+30.00, 30.14 LT

Temp. Benchmark #46
LAG Screw set 2' up 6" Tree
Elevation = 151.84
Sta. 312+49.71, 4.80 RT

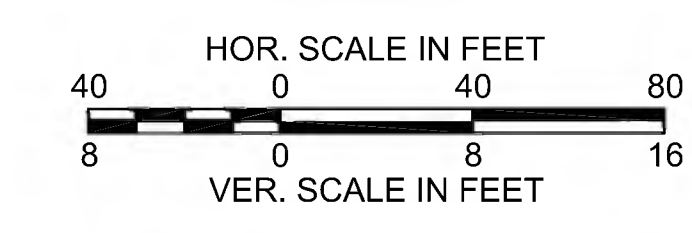

FOR CONSTRUCTION PLANS SEE SHEET NO. 38, 39, 40 & 41

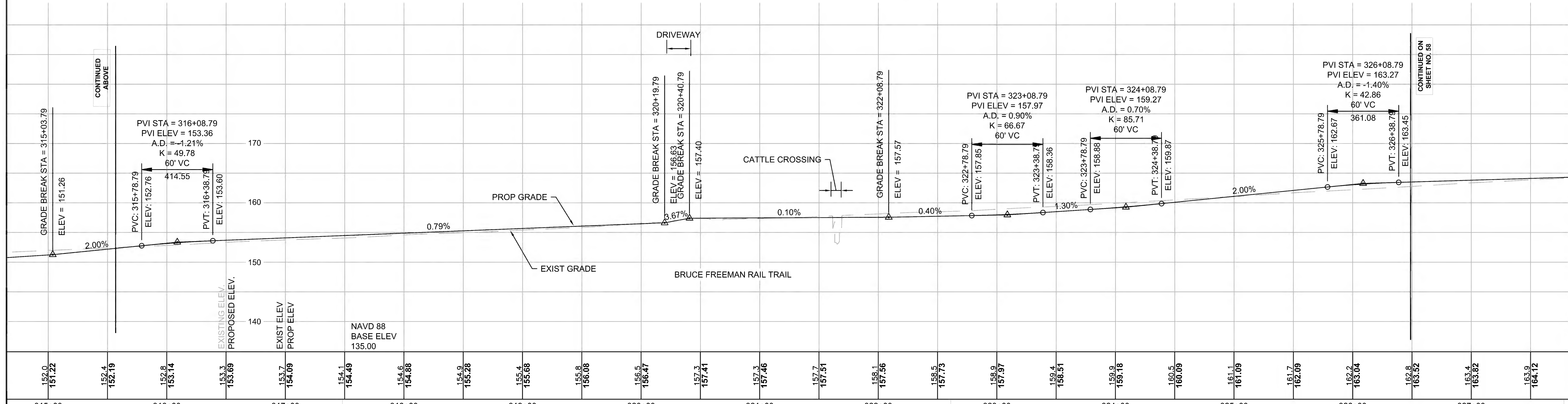

Station	Existing Elev.	Proposed Elev.
315+00	152.0	151.22
316+00	152.8	153.14
317+00	153.3	153.69
318+00	154.1	154.49
319+00	155.4	155.68
320+00	156.5	156.47
321+00	157.3	157.41
322+00	158.1	157.56
323+00	158.9	157.97
324+00	159.9	159.18
325+00	161.1	161.09
326+00	162.2	163.04
327+00	163.4	163.82

Temp. Benchmark #47
LAG Screw set 1' up 26" Tree
Elevation = 155.62
Sta. 317+48.09, 11.52 LT

Temp. Benchmark #48
LAG Screw set 2' up 9" Tree
Elevation = 160.52
Sta. 322+61.12, 6.29 RT

Temp. Benchmark #49
LAG Screw set 1' up 6" Tree
Elevation = 164.12
Sta. 327+78.17

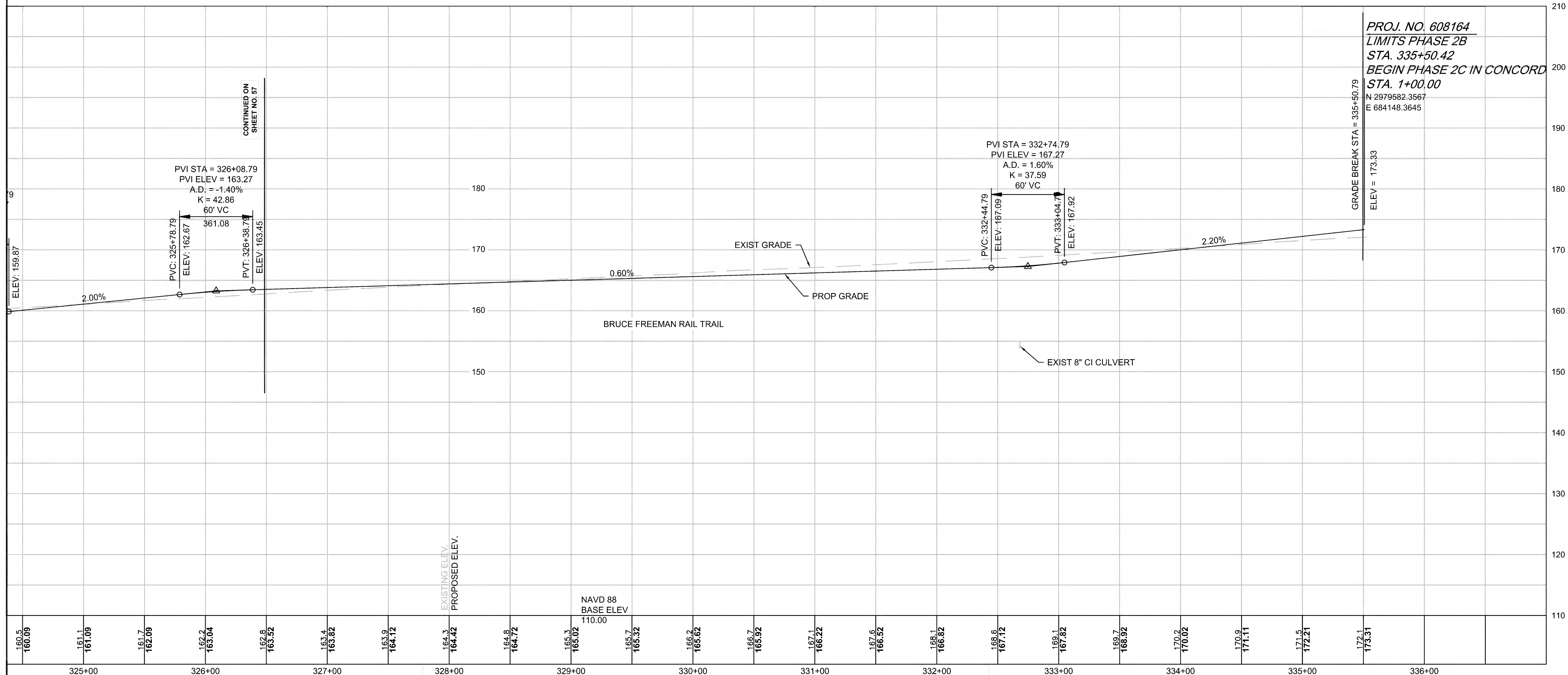

PROJ. NO. 608164
LIMITS PHASE 2B
STA. 335+50.42
BEGIN PHASE 2C IN CONCORD
STA. 1+00.00
 N 2979582.3567
 E 684148.3645

PVI STA = 326+08.79
 PVI ELEV = 163.27
 A.D. = -1.40%
 K = 42.86
 60' VC

PVI STA = 332+74.79
 PVI ELEV = 167.27
 A.D. = 1.60%
 K = 37.59
 60' VC

Temp. Benchmark #49
 LAG Screw set 2'
 up 6" Tree
 Elevation = 166.20'
 Sta. 327+78.17, 6.18 RT

Temp. Benchmark #50
 LAG Screw set 2'
 up 10" Tree
 Elevation = 169.70'
 Sta. 332+42.93, 11.68 LT

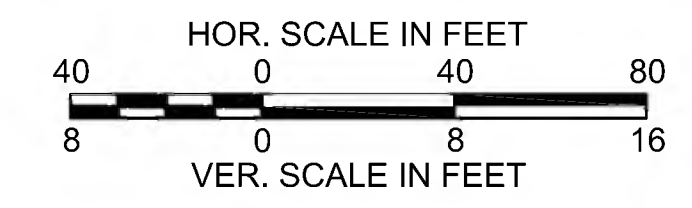

FOR CONSTRUCTION PLANS SEE SHEET NO. 41 & 42

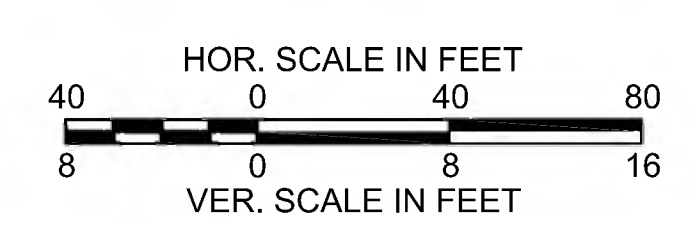
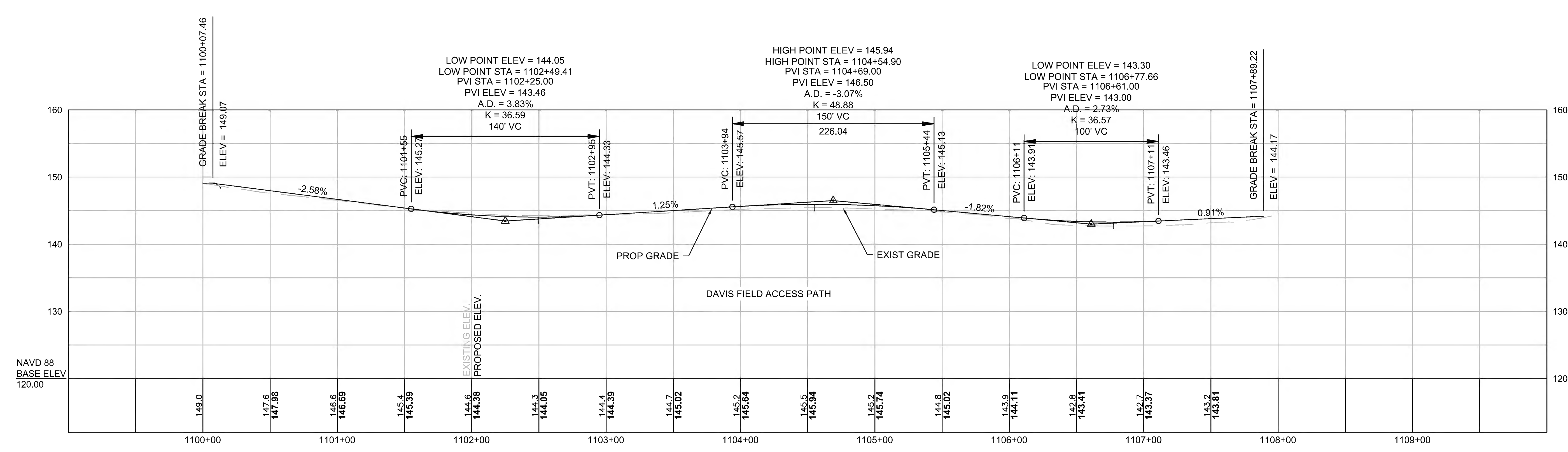
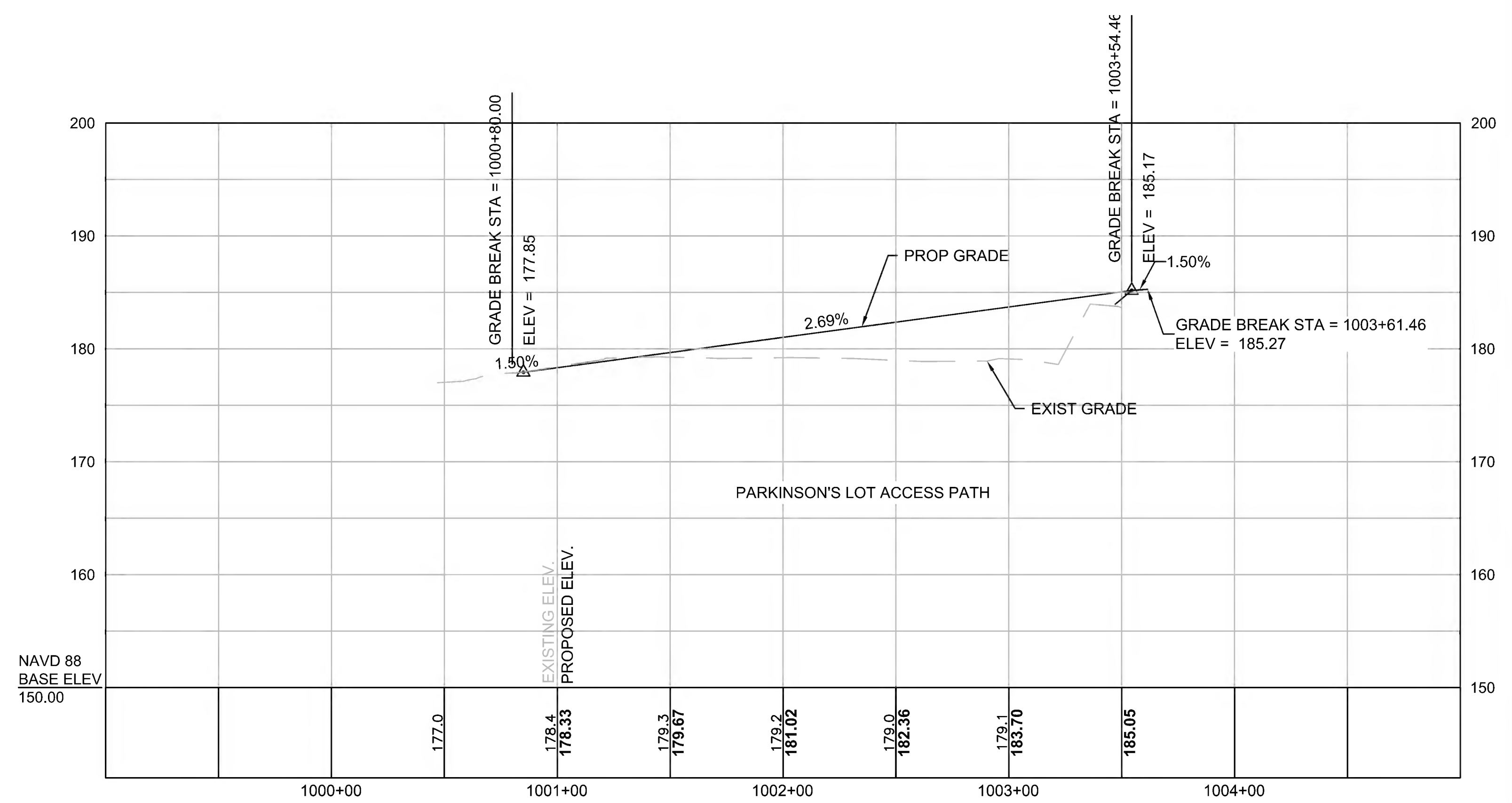
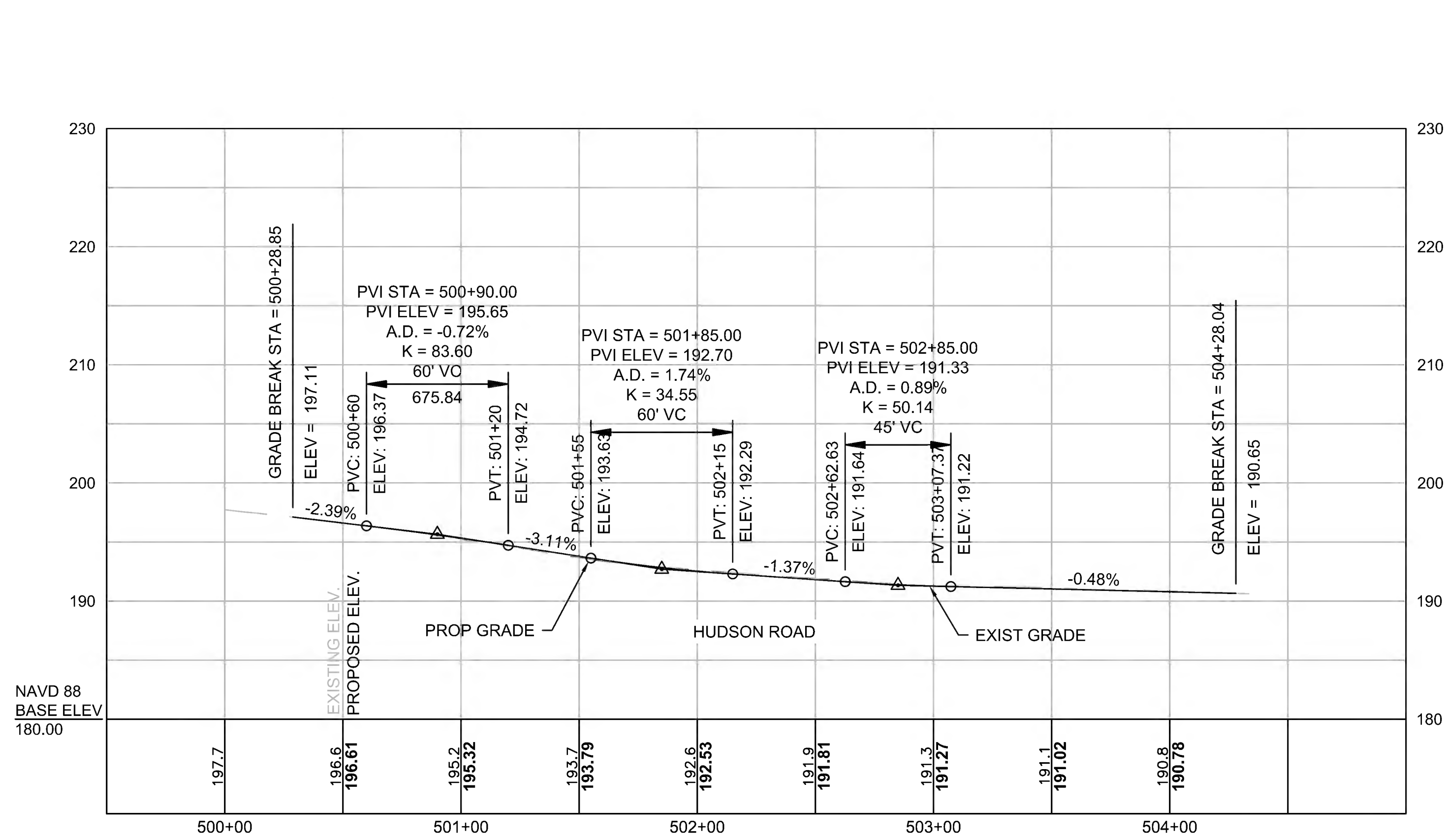

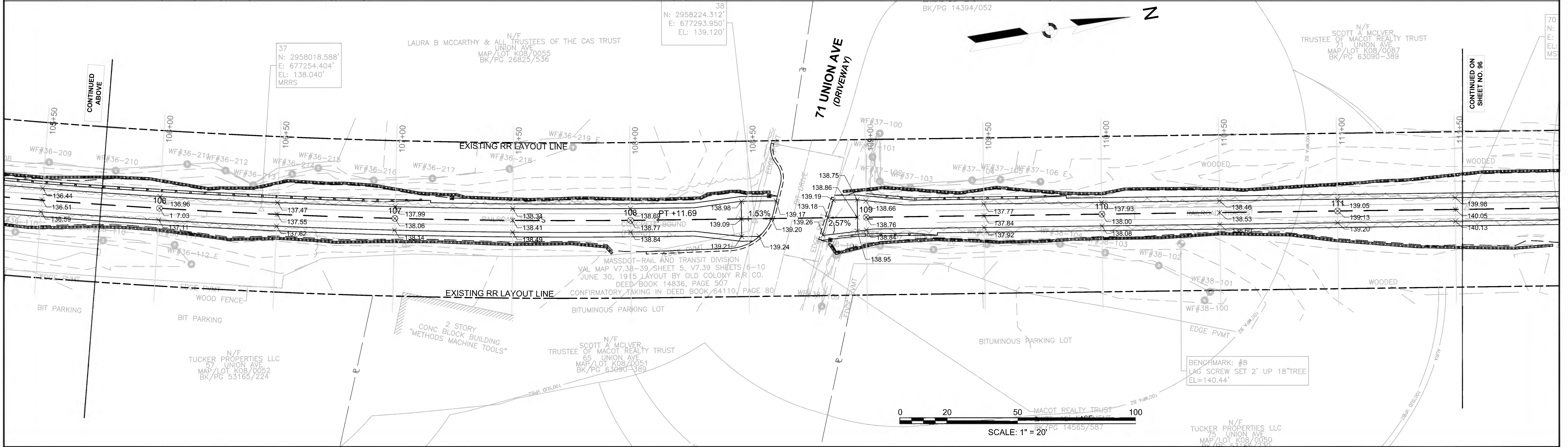
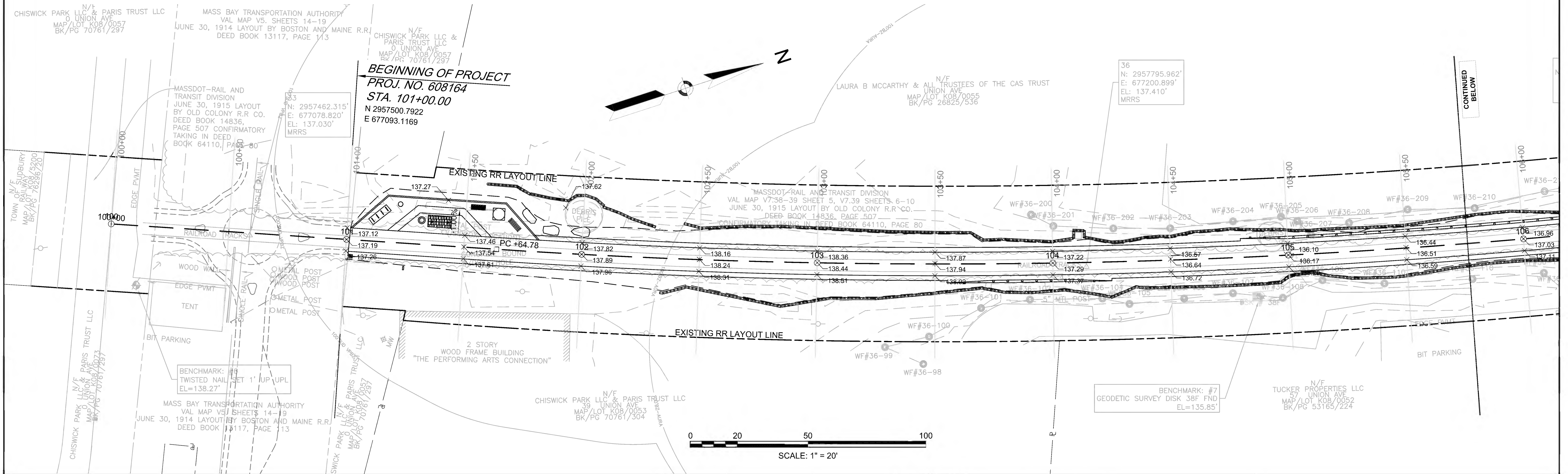

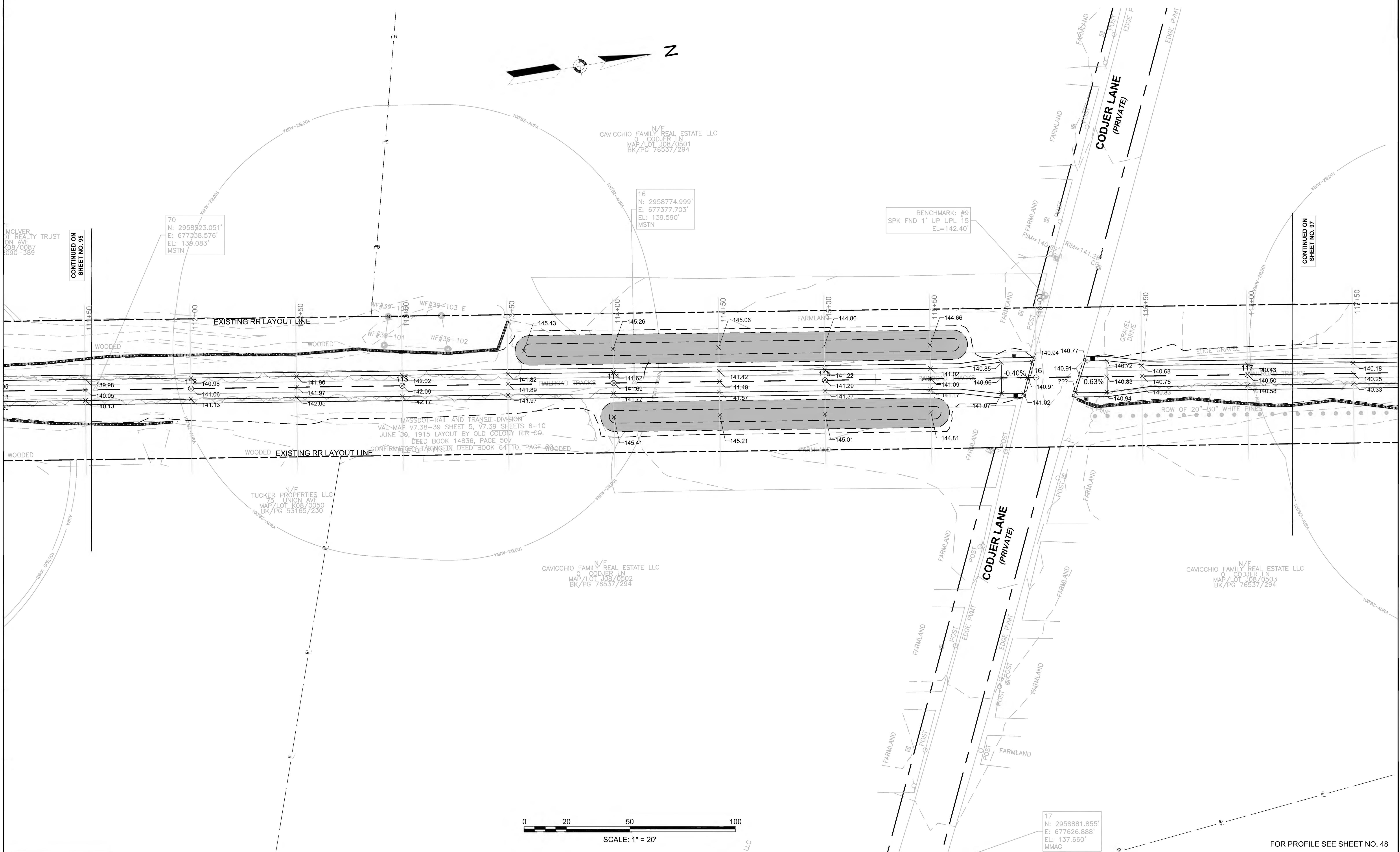
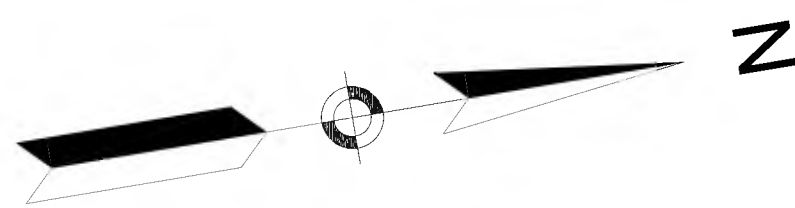

CONTINUED ON
SHEET NO. 95

CONTINUED ON
SHEET NO. 97

70
N: 2958823.051'
E: 677338.576'
EL: 139.083'
MSTN

16
N: 2958774.999'
E: 677377.703'
EL: 139.590'
MSTN

BENCHMARK: #9
SPK FND 1' UP UPL 15
EL=142.40'

17
N: 2958881.855'
E: 677626.888'
EL: 137.660'
MMAG

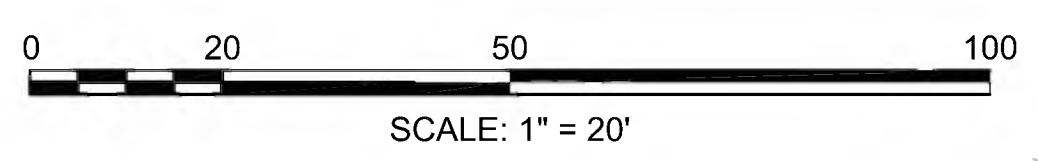

FOR PROFILE SEE SHEET NO. 48

**SUDBURY
BRUCE FREEMAN RAIL TRAIL**

STATE	FED AID PROJ. NO.	SHEET NO.	TOTAL SHEETS
MA	XXX-XXXX(XXX)X	97	319
PROJECT FILE NO.		608164	

GRADING PLANS

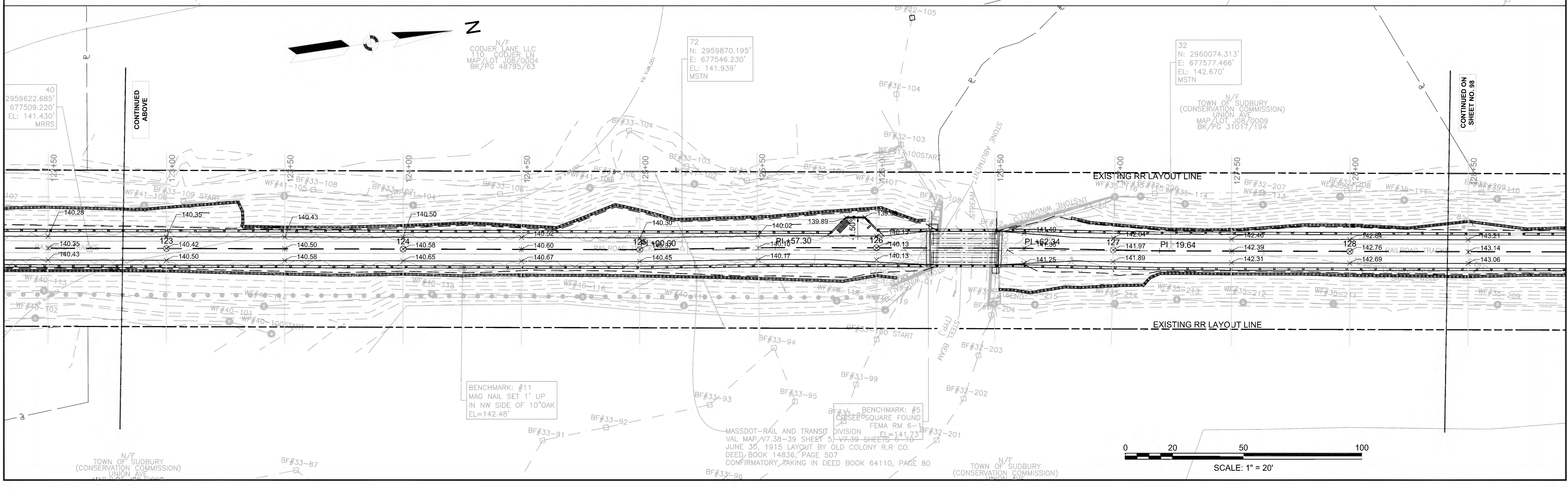
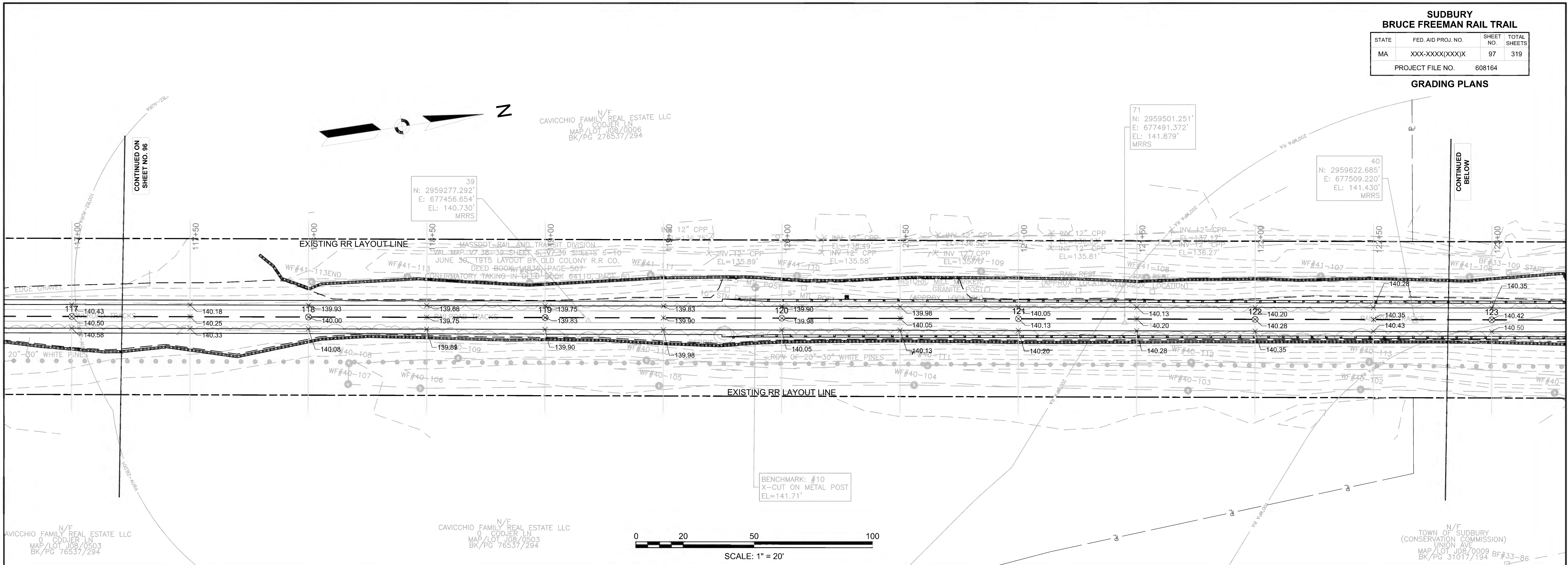

**SUDBURY
BRUCE FREEMAN RAIL TRAIL**

STATE	FED. AID PROJ. NO.	SHEET NO.	TOTAL SHEETS
MA	XXX-XXXX(XXX)X	98	319
PROJECT FILE NO.		608164	

GRADING PLANS

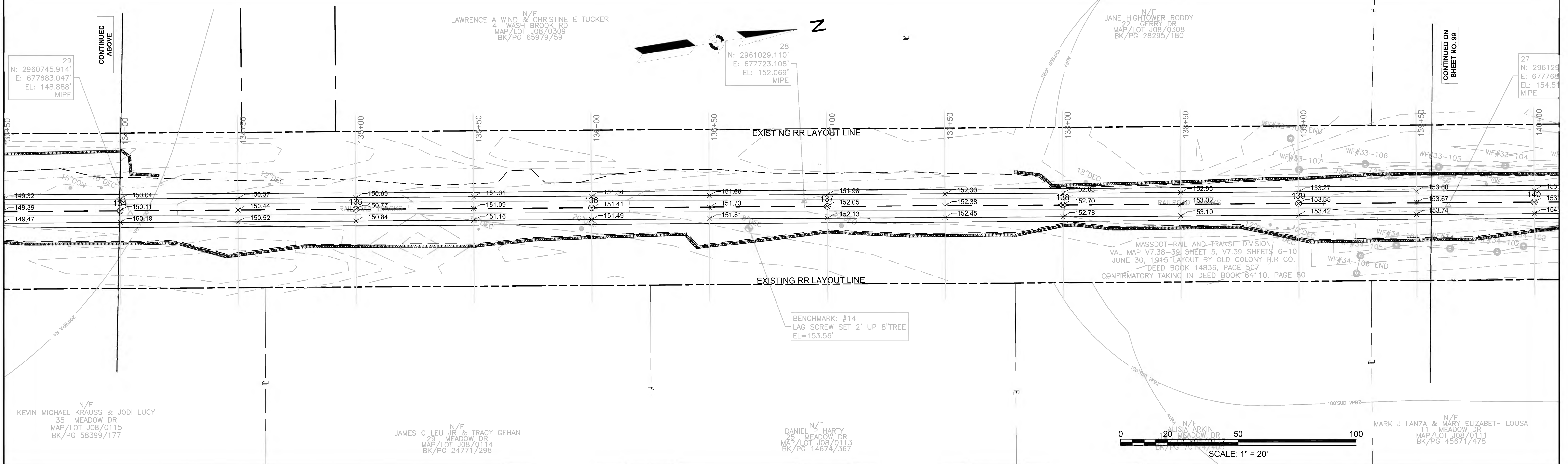
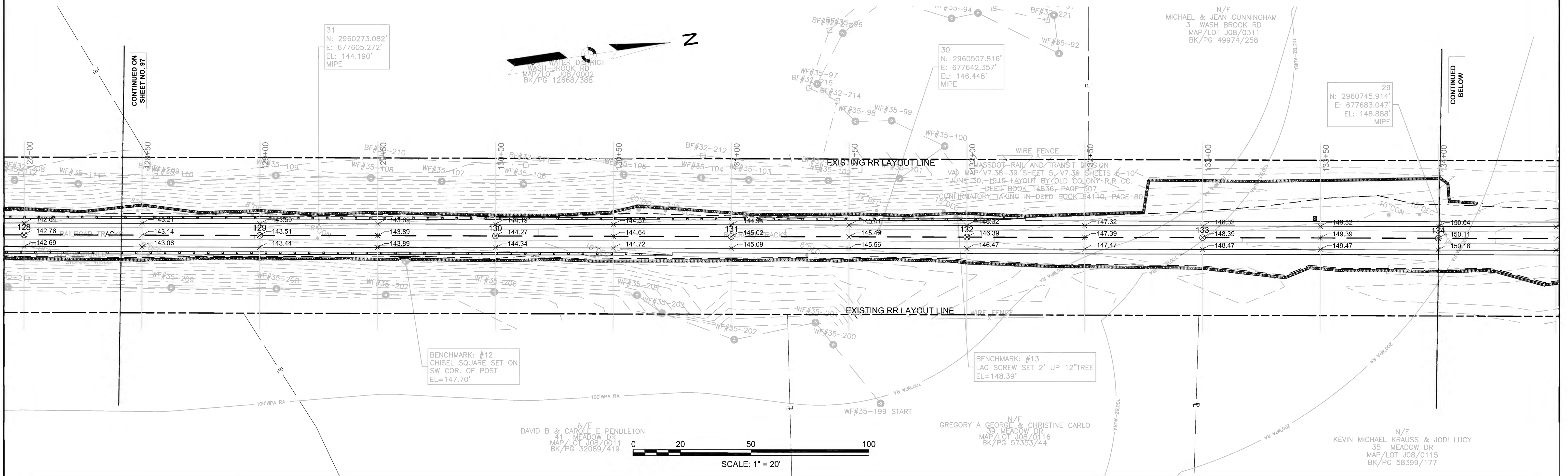

SUDBURY
BRUCE FREEMAN RAIL TRAIL

STATE	FED. AID PROJ. NO.	SHEET NO.	TOTAL SHEETS
MA	XXX-XXXX(XXX)X	99	319

PROJECT FILE NO. 608164
GRADING PLANS

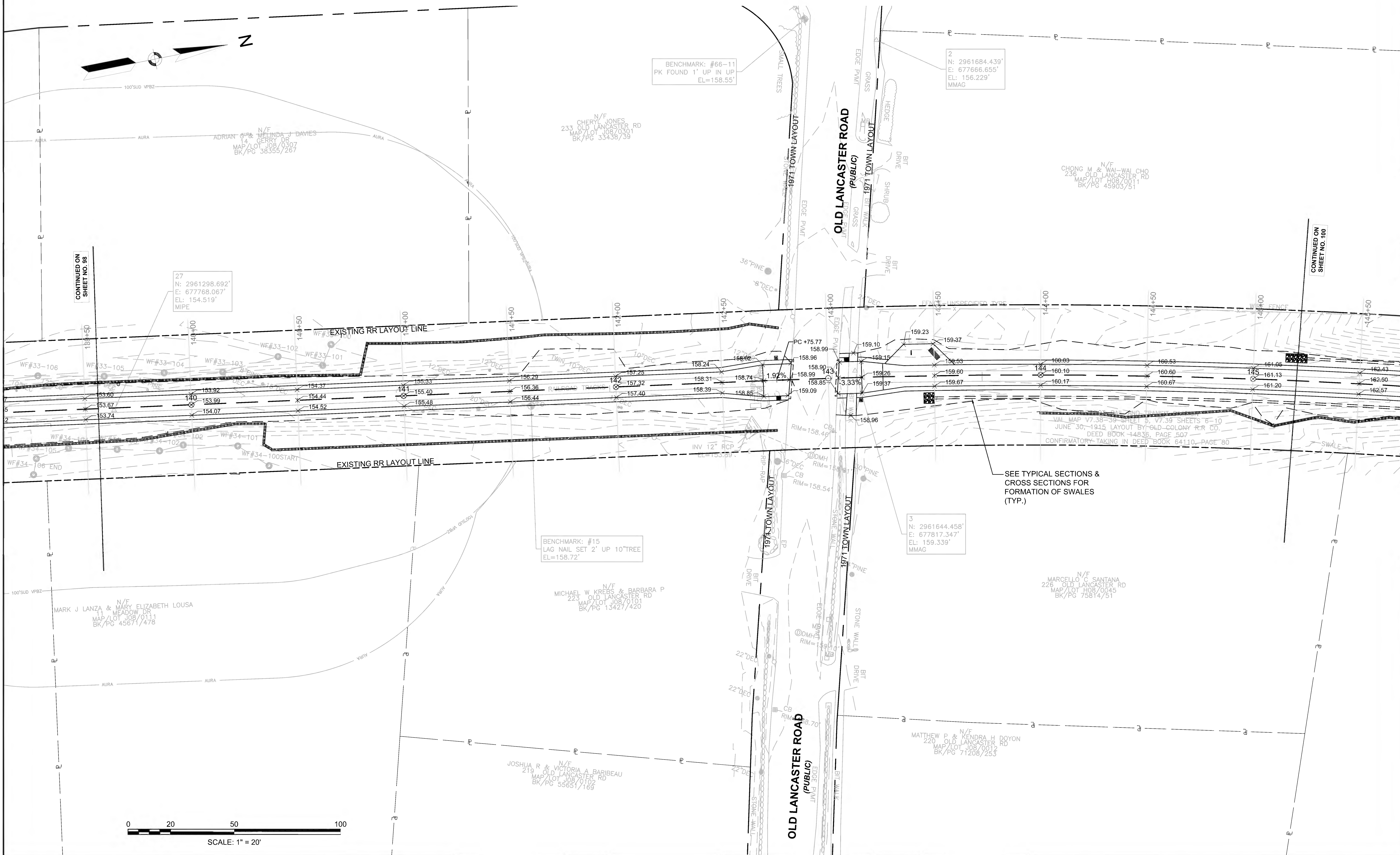
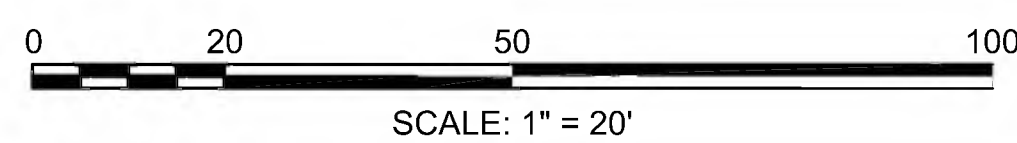
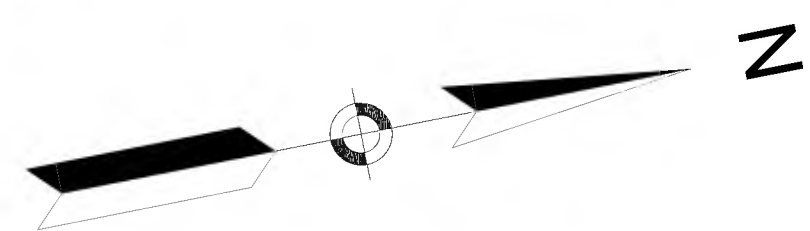

CONTINUED ON SHEET NO. 98

CONTINUED ON SHEET NO. 100

27
N: 2961298.692'
E: 677768.067'
EL: 154.519'
MIPE

BENCHMARK: #66-11
PK FOUND 1' UP IN UP
EL=158.55'

2
N: 2961684.439'
E: 677666.655'
EL: 156.229'
MMAG

BENCHMARK: #15
LAG NAIL SET 2' UP 10" TREE
EL=158.72'

3
N: 2961644.458'
E: 677817.347'
EL: 159.339'
MMAG

SEE TYPICAL SECTIONS &
CROSS SECTIONS FOR
FORMATION OF SWALES
(TYP.)

N/F
MARCELLO C. SANTANA
226 OLD LANCASTER RD
MAP/LOT 108/0045
BK/PG 75814/51

N/F
MATTHEW P. & KENDRA H. DOYON
220 OLD LANCASTER RD
MAP/LOT 108/0019
BK/PG 71208/253

N/F
JOSHUA R. & VICTORIA A. BARIBEAU
219 OLD LANCASTER RD
MAP/LOT 108/0102
BK/PG 55651/169

N/F
MICHAEL W. KREBS & BARBARA P.
223 OLD LANCASTER RD
MAP/LOT 108/0101
BK/PG 13427/420

N/F
ADRIAN G. & MELINDA J. DAVIES
14 GERRY DR
MAP/LOT 105/0307
BK/PG 38355/267

N/F
CHERYL JONES
233 OLD LANCASTER RD
MAP/LOT 108/0301
BK/PG 33436/39

N/F
CHONG M. & WAL-WAL CHO
236 OLD LANCASTER RD
MAP/LOT 108/0011
BK/PG 45903/51

**SUDBURY
BRUCE FREEMAN RAIL TRAIL**

STATE	FED. AID PROJ. NO.	SHEET NO.	TOTAL SHEETS
MA	XXX-XXXX(XXX)X	100	319
PROJECT FILE NO.		608164	

GRADING PLANS

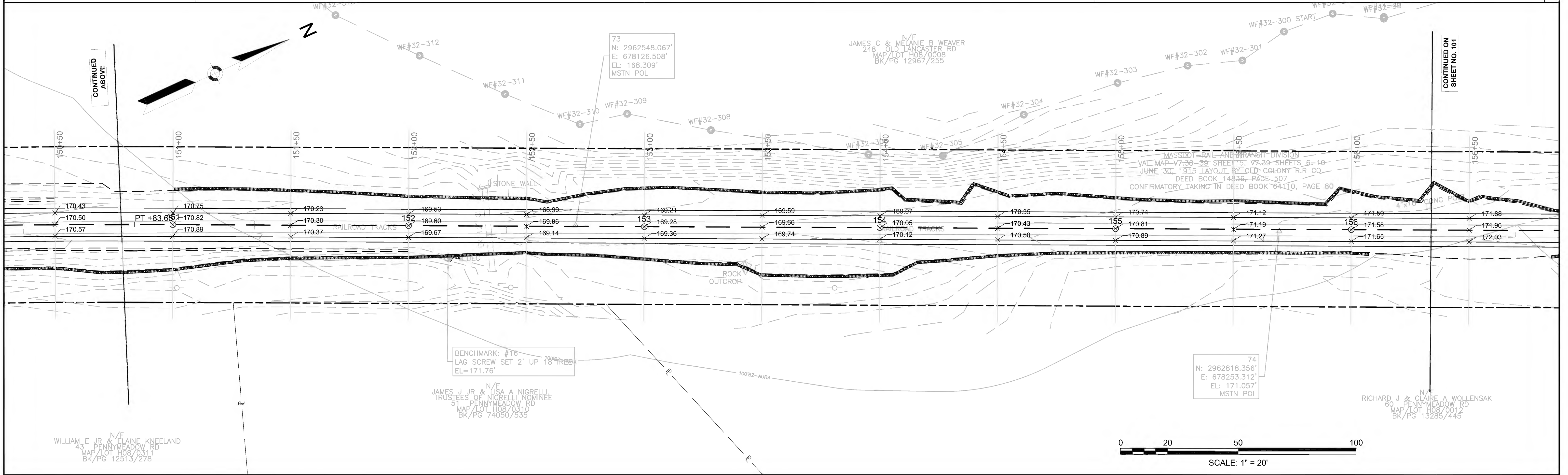
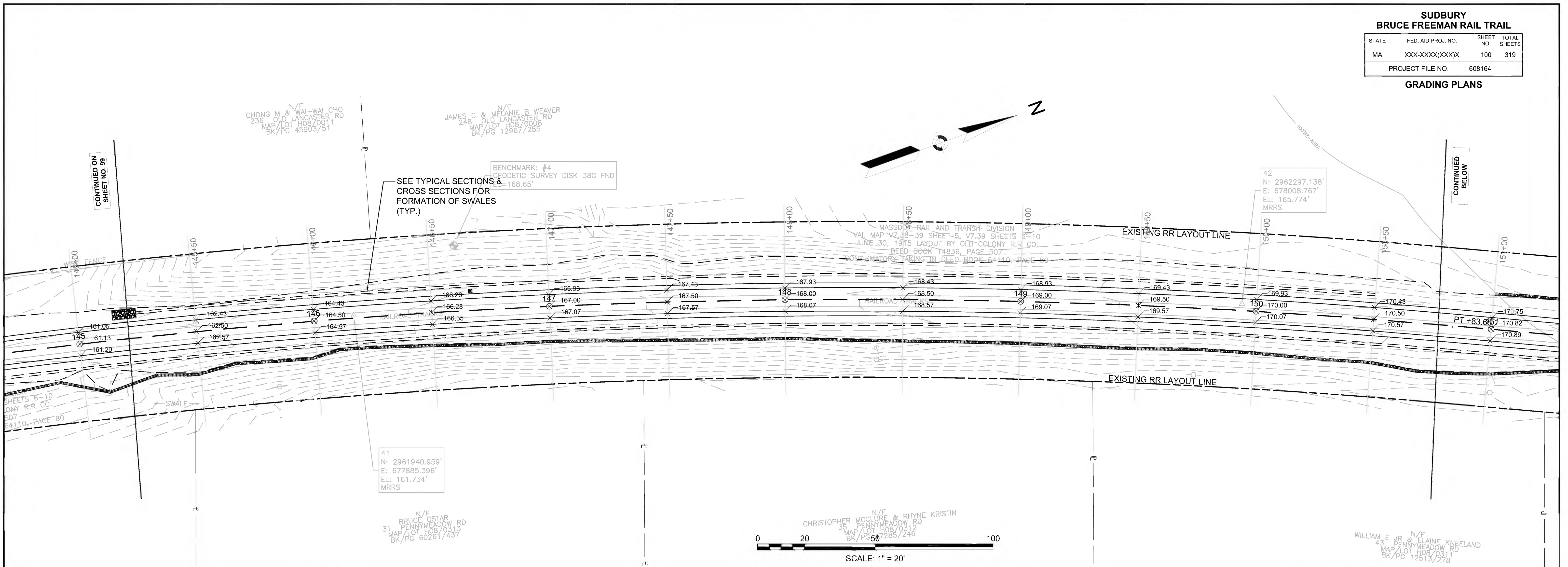

**SUDBURY
BRUCE FREEMAN RAIL TRAIL**

STATE	FED. AID PROJ. NO.	SHEET NO.	TOTAL SHEETS
MA	XXX-XXXX(XXX)X	102	319
PROJECT FILE NO.		608164	

GRADING PLANS

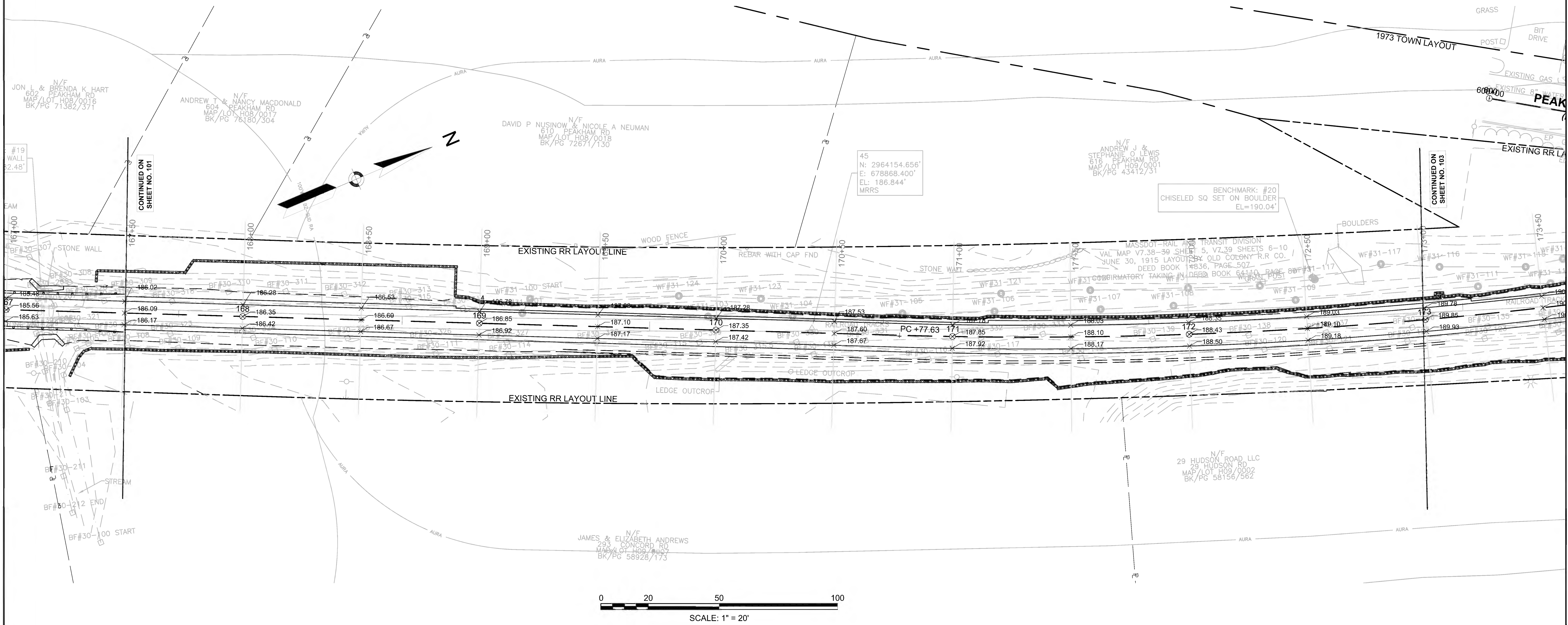

**SUDBURY
BRUCE FREEMAN RAIL TRAIL**

STATE	FED AID PROJ. NO.	SHEET NO.	TOTAL SHEETS
MA	XXX-XXXX(XXX)X	103	319
PROJECT FILE NO.		608164	

GRADING PLANS

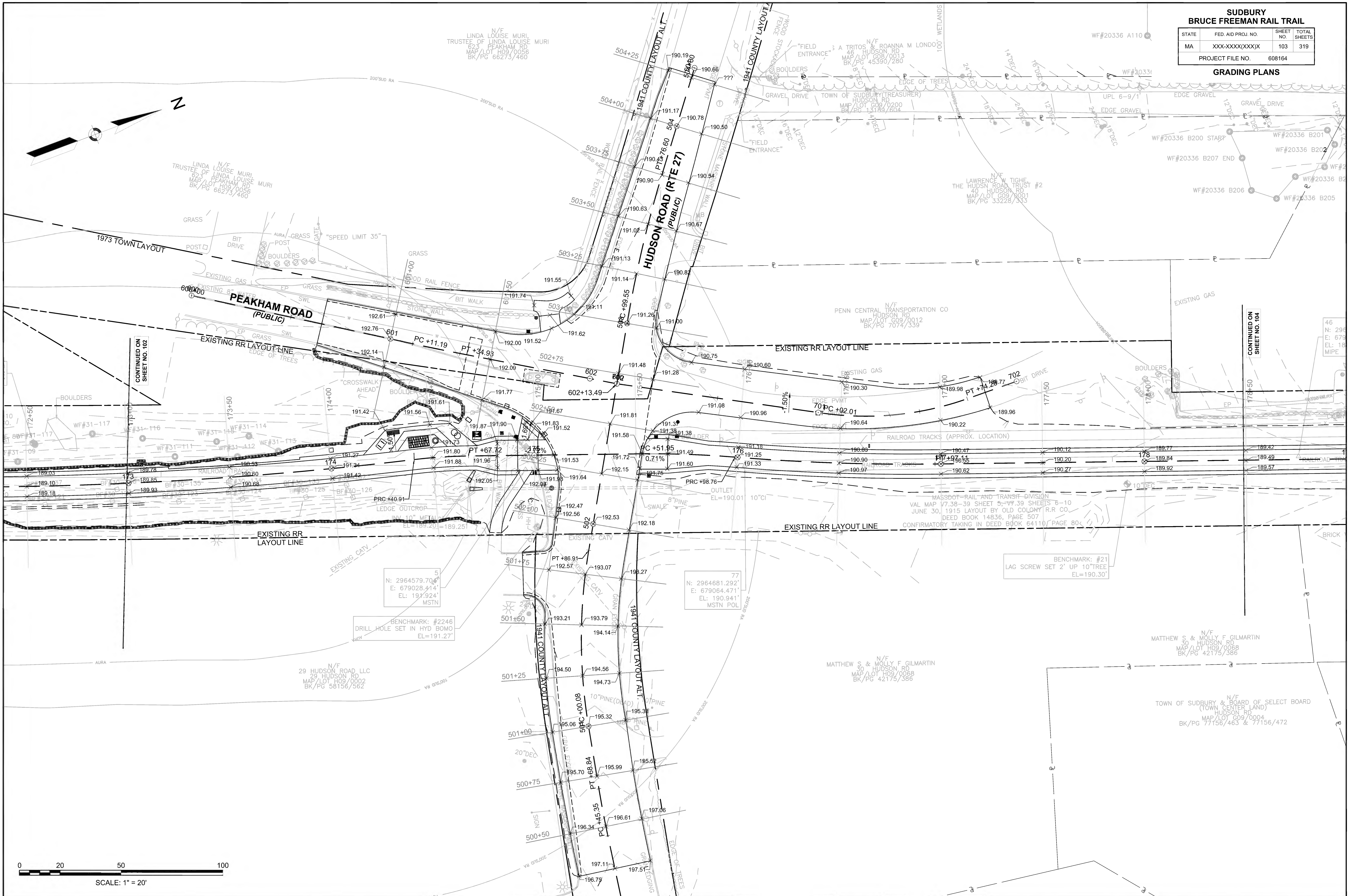

CONTINUED ON SHEET NO. 102

CONTINUED ON SHEET NO. 104

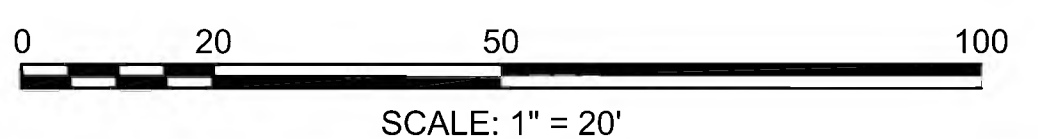

**SUDBURY
BRUCE FREEMAN RAIL TRAIL**

STATE	FED. AID PROJ. NO.	SHEET NO.	TOTAL SHEETS
MA	XXX-XXXX(XXX)X	104	319
PROJECT FILE NO.		608164	

GRADING PLANS

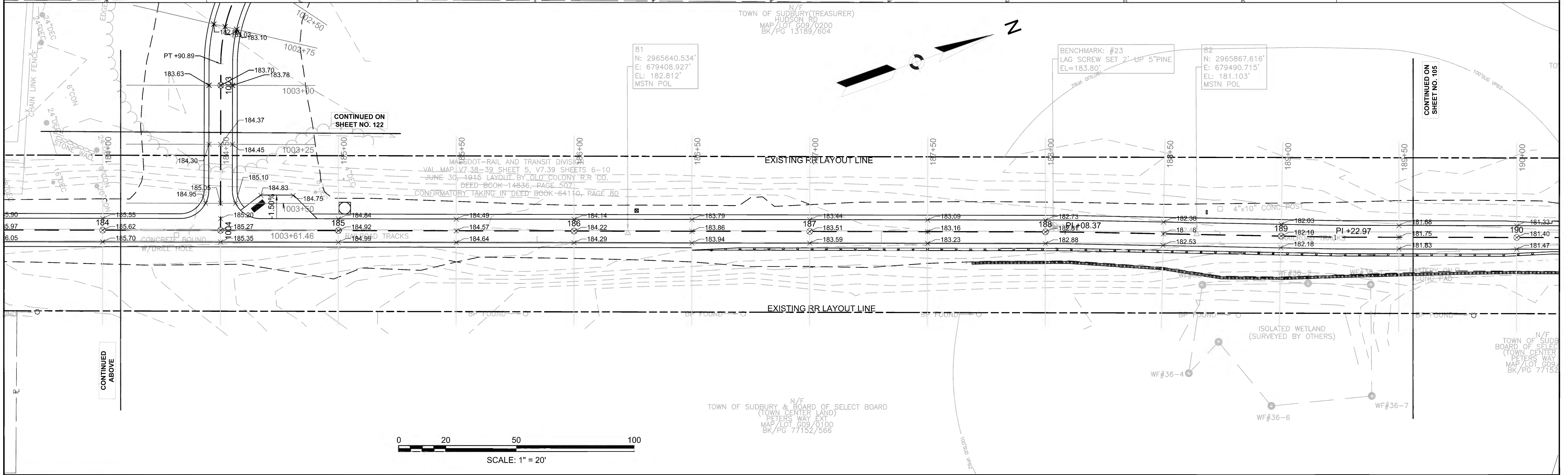
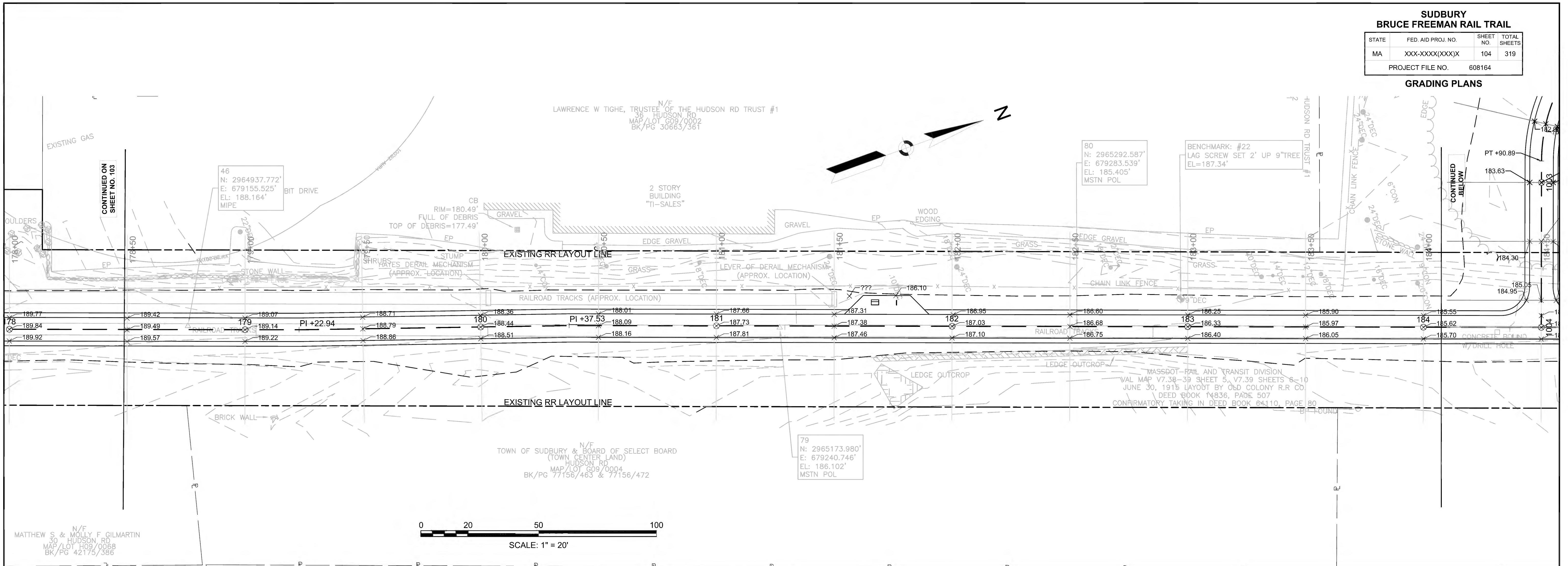

SUDBURY
BRUCE FREEMAN RAIL TRAIL

STATE	FED. AID PROJ. NO.	SHEET NO.	TOTAL SHEETS
MA	XXX-XXXX(XXX)X	105	319
PROJECT FILE NO.		608164	

GRADING PLANS

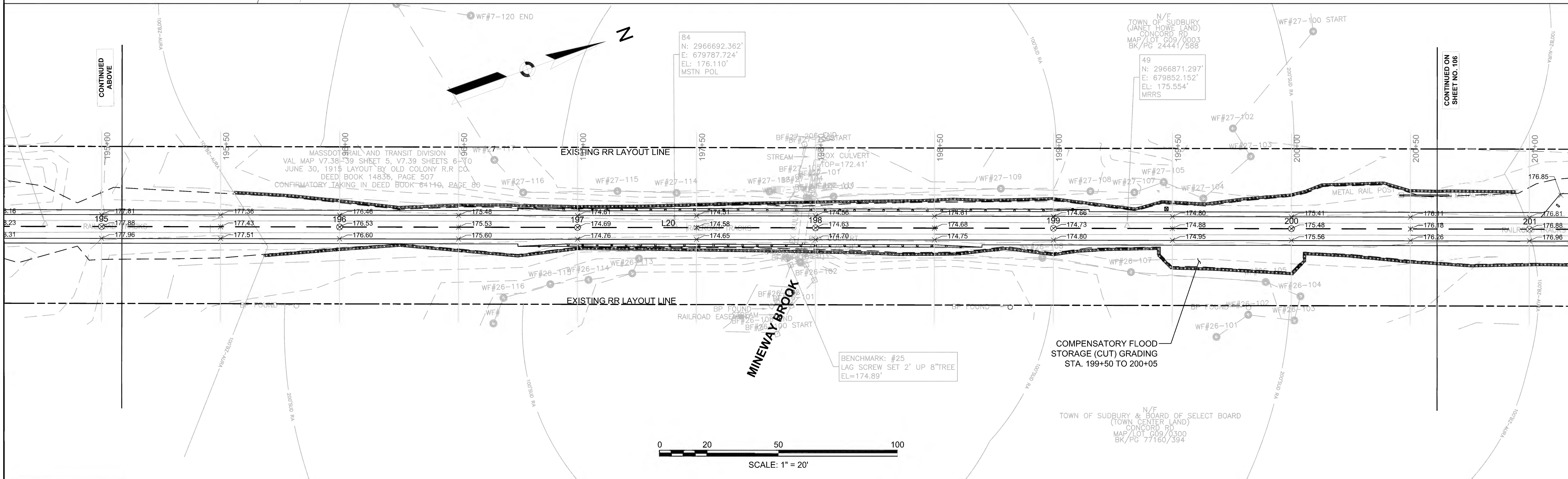
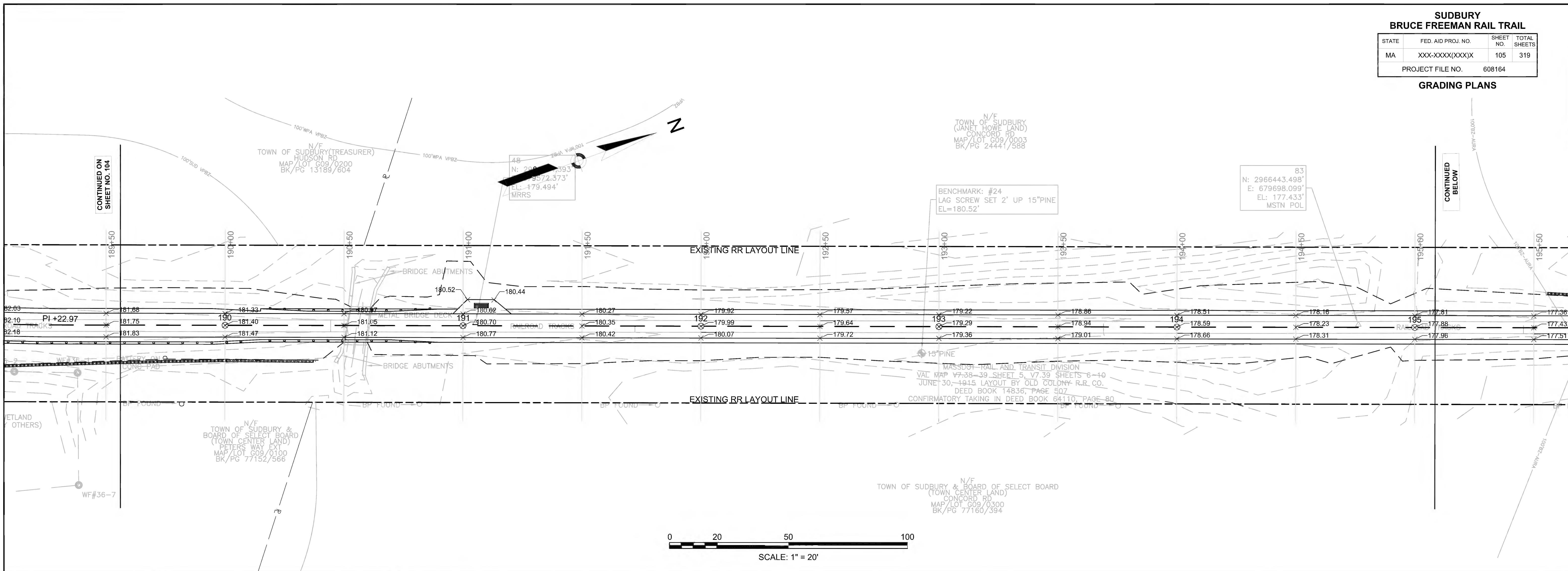

**SUDBURY
BRUCE FREEMAN RAIL TRAIL**

STATE	FED. AID PROJ. NO.	SHEET NO.	TOTAL SHEETS
MA	XXX-XXXX(XXX)X	106	319

PROJECT FILE NO. 608164

GRADING PLANS

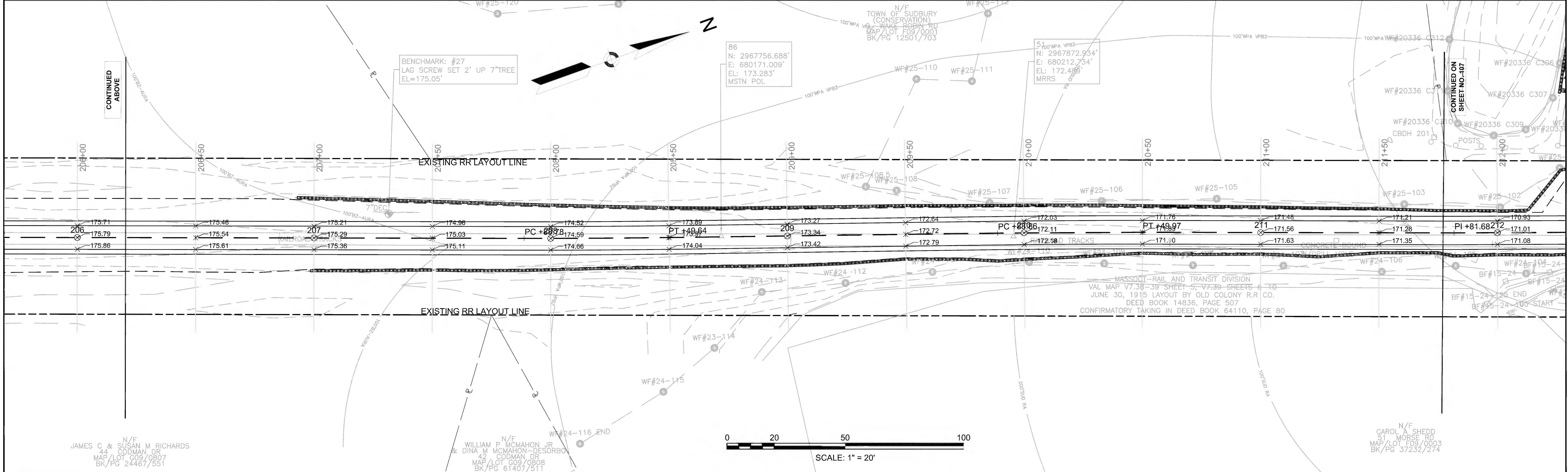
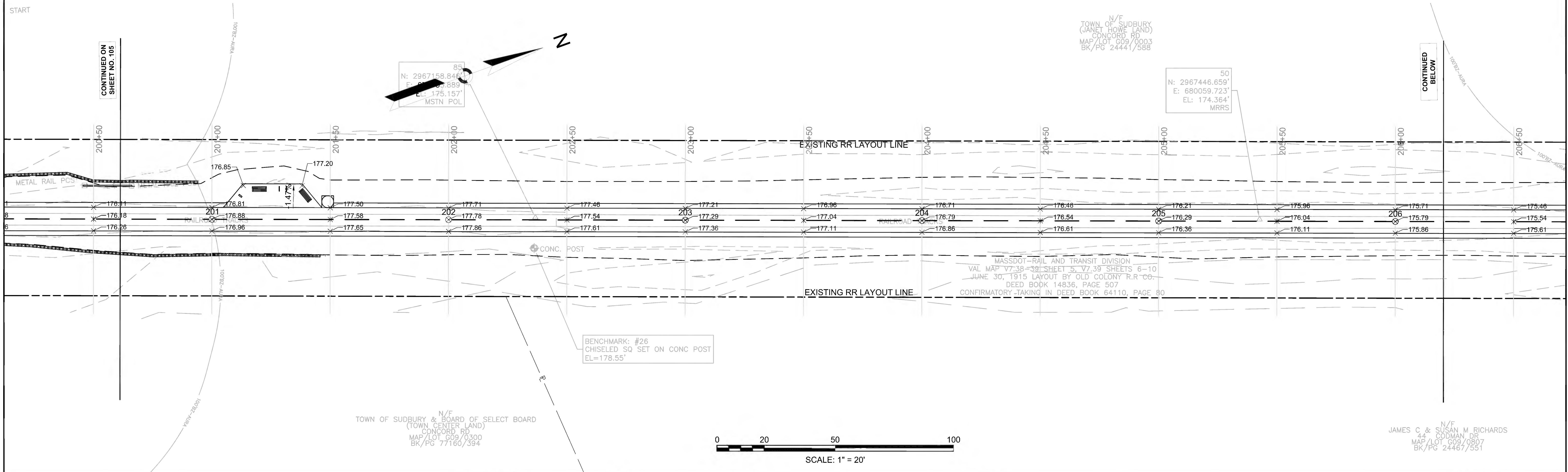

608164_HD(GRADING PLANS).DWG Plotted on 18-Feb-2022 3:56 PM

SUDBURY
BRUCE FREEMAN RAIL TRAIL

STATE	FED. AID PROJ. NO.	SHEET NO.	TOTAL SHEETS
MA	XXX-XXXX(XXX)X	108	319
PROJECT FILE NO.		608164	

GRADING PLANS

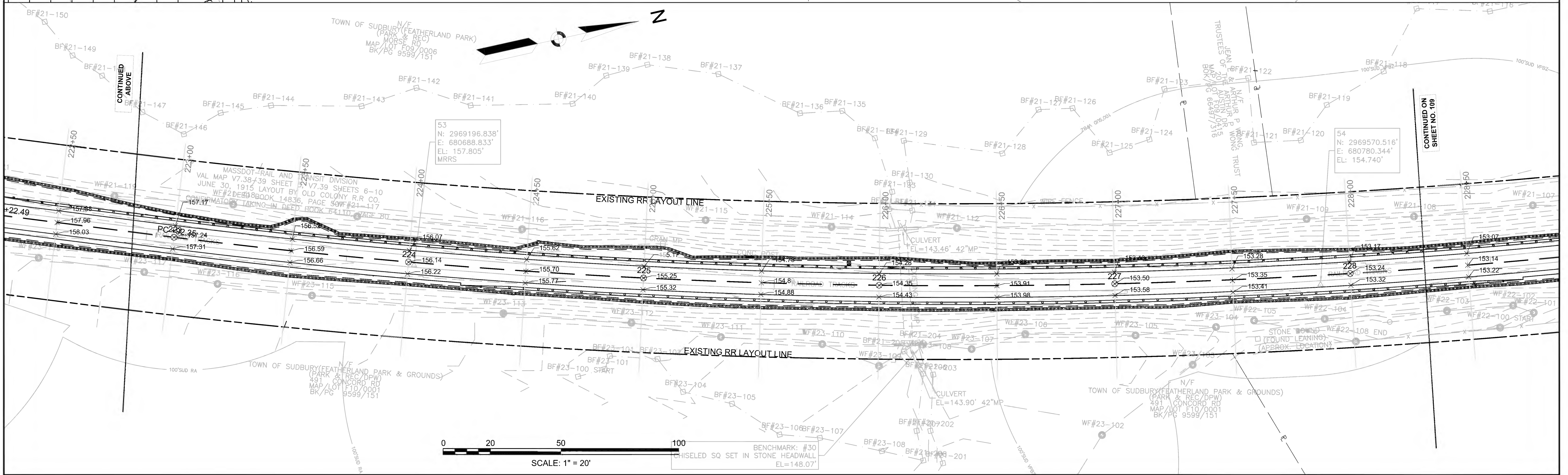
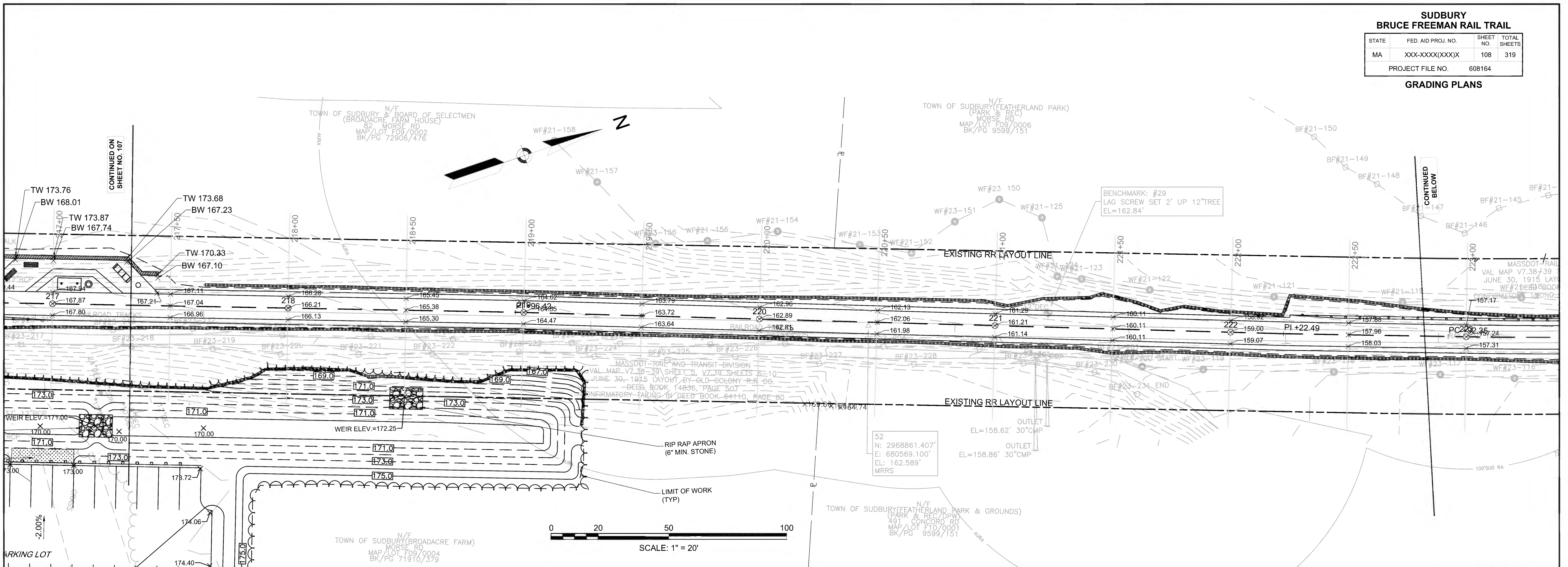

**SUDBURY
BRUCE FREEMAN RAIL TRAIL**

STATE	FED. AID PROJ. NO.	SHEET NO.	TOTAL SHEETS
MA	XXX-XXXX(XXX)X	109	319
PROJECT FILE NO.		608164	

GRADING PLANS

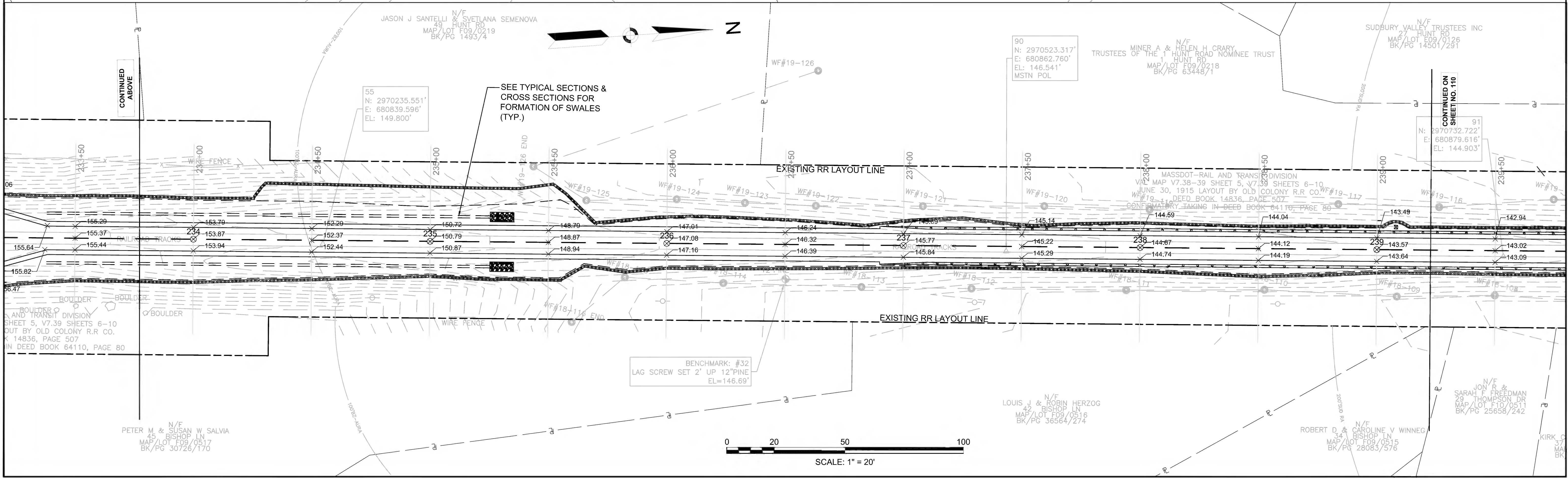
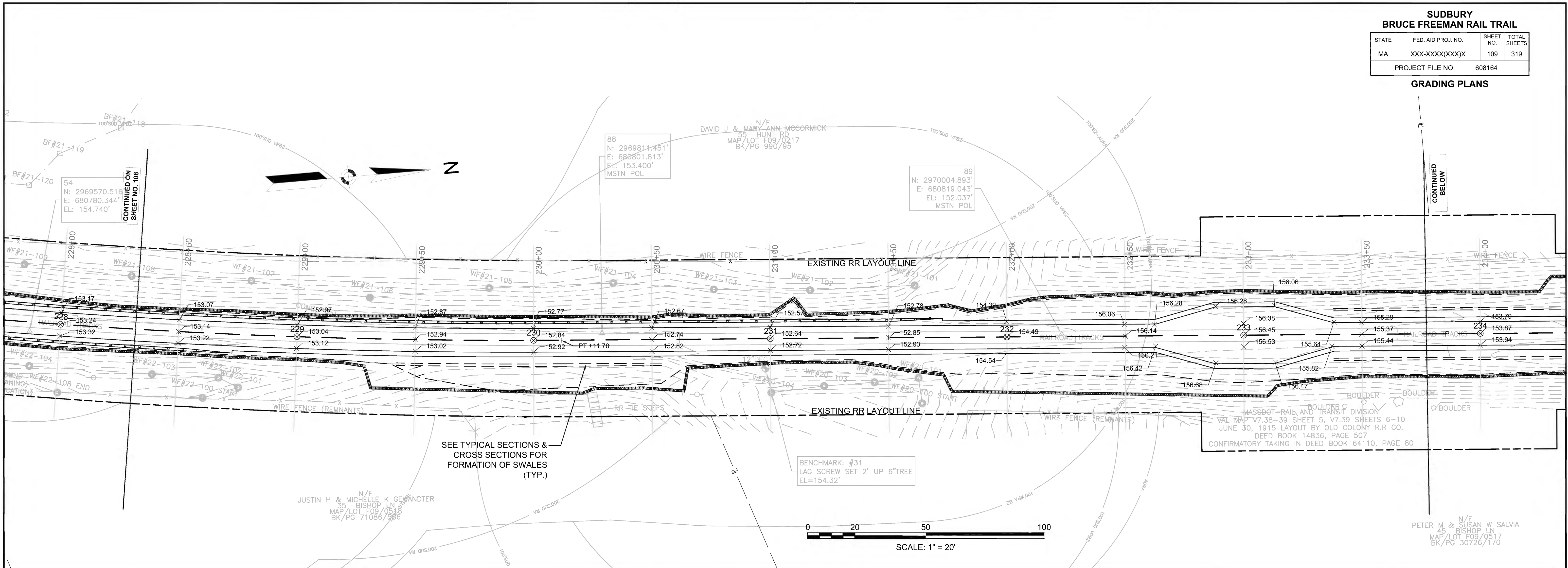

SUDBURY BRUCE FREEMAN RAIL TRAIL			
STATE	FED AID PROJ. NO.	SHEET NO.	TOTAL SHEETS
MA	XXX-XXXX(XXX)X	110	319
PROJECT FILE NO.		608164	

GRADING PLANS

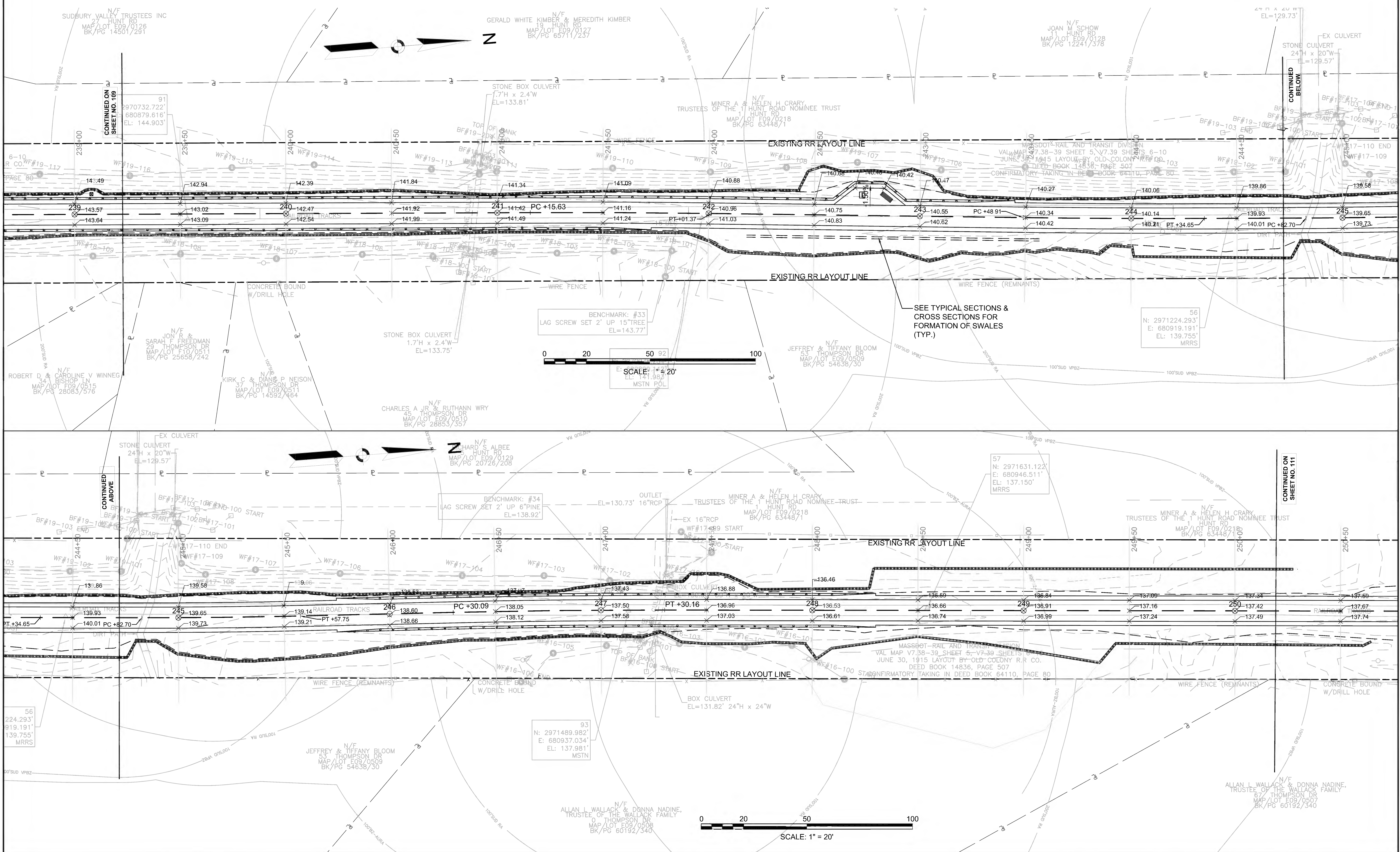

**SUDBURY
BRUCE FREEMAN RAIL TRAIL**

STATE	FED. AID PROJ. NO.	SHEET NO.	TOTAL SHEETS
MA	XXX-XXXX(XXX)X	111	319
PROJECT FILE NO.		608164	

GRADING PLANS

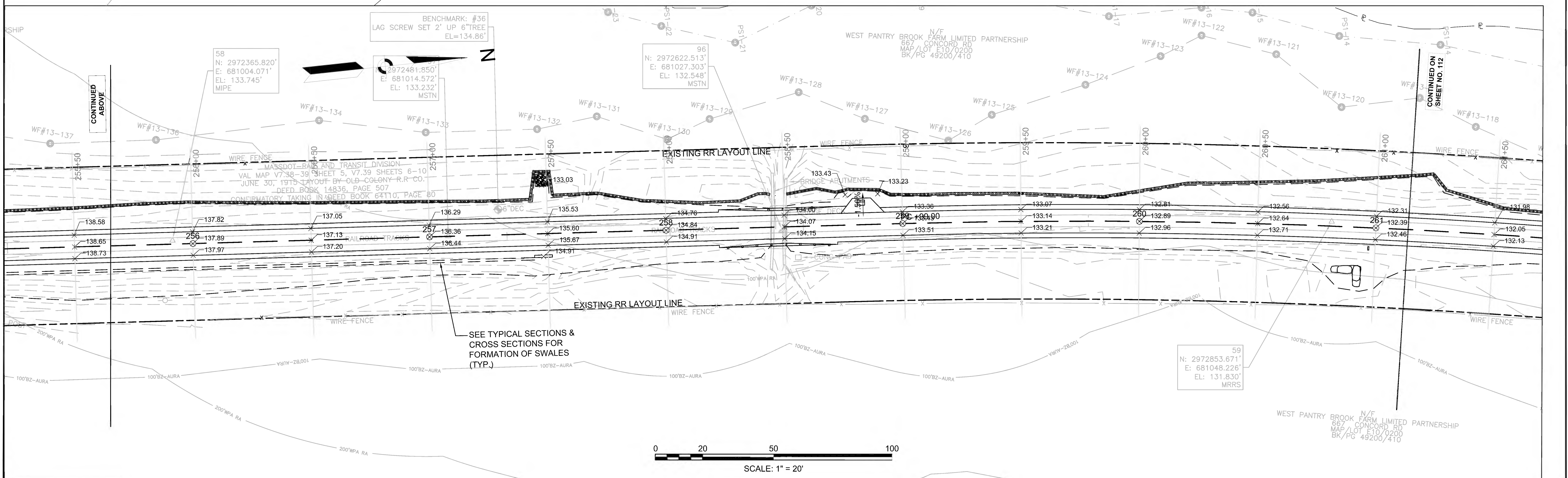
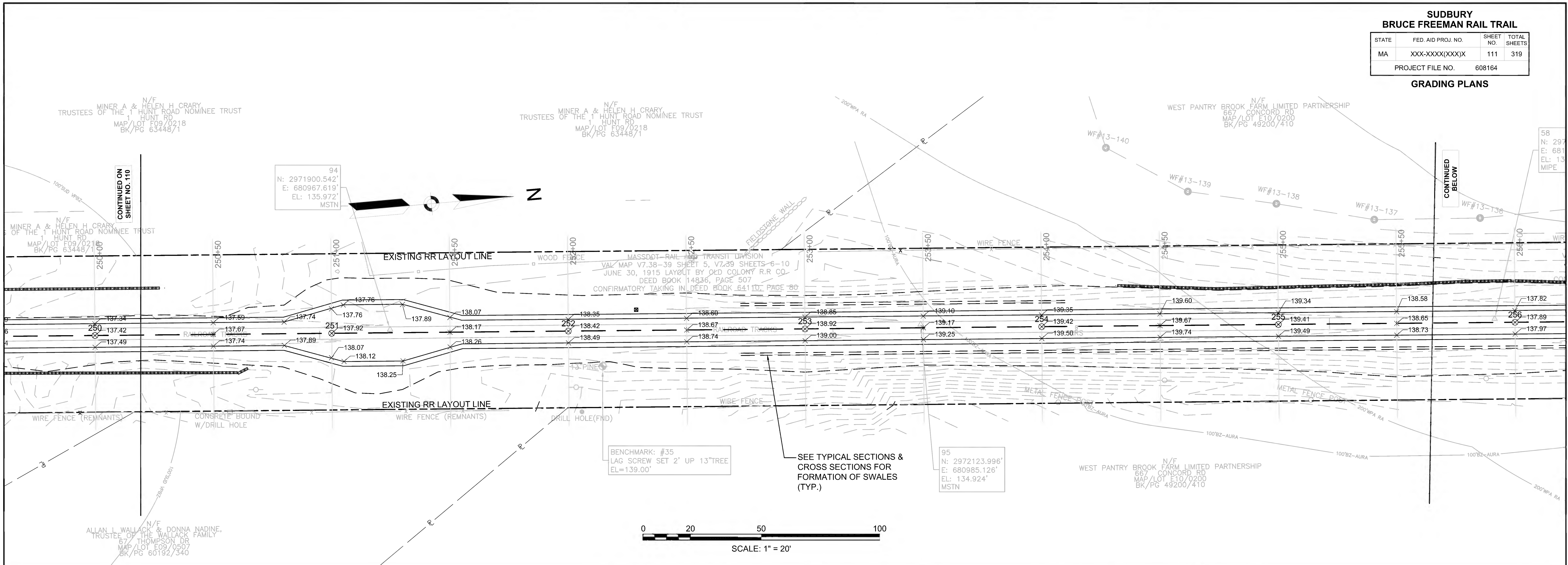

**SUDBURY
BRUCE FREEMAN RAIL TRAIL**

STATE	FED AID PROJ. NO.	SHEET NO.	TOTAL SHEETS
MA	XXX-XXXX(XXX)X	112	319
PROJECT FILE NO.		608164	

GRADING PLANS

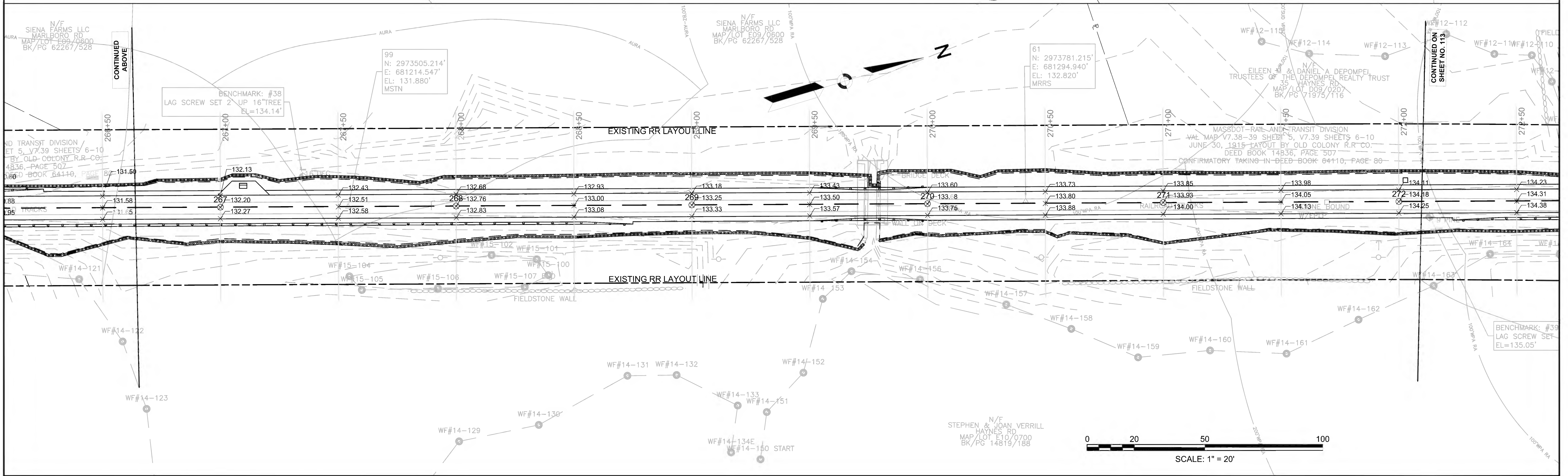
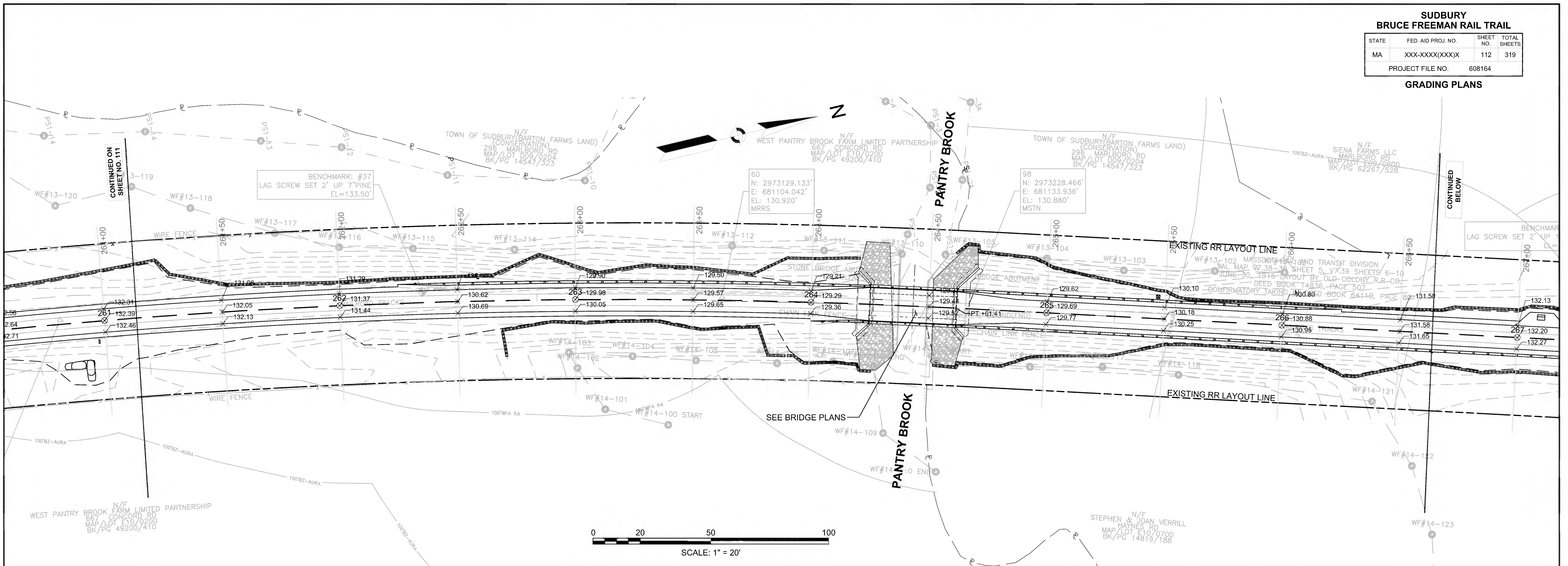

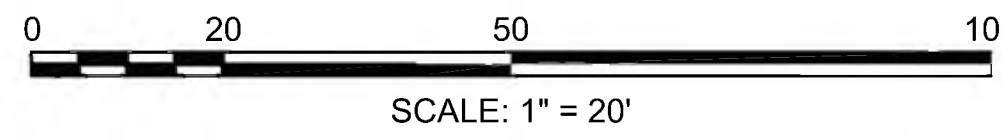
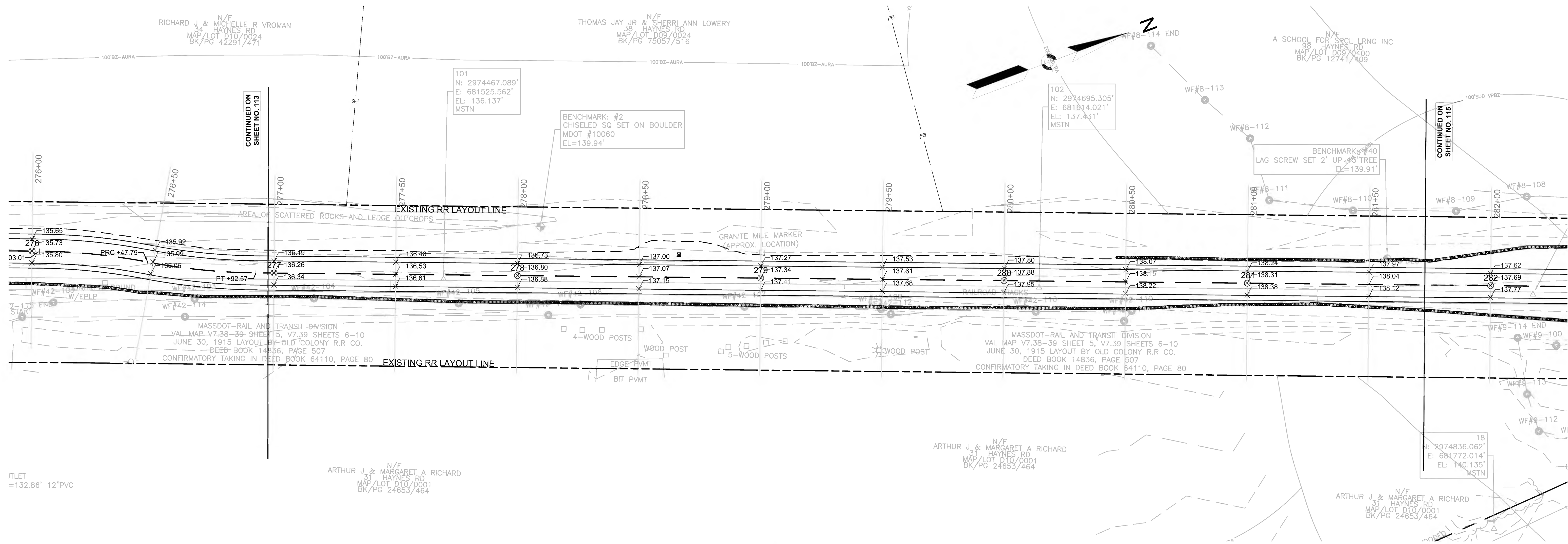

CONTINUED ON
SHEET NO. 113

CONTINUED ON
SHEET NO. 115

ITILET
= 132.86' 12" PVC

SUDBURY
BRUCE FREEMAN RAIL TRAIL

STATE	FED. AID PROJ. NO.	SHEET NO.	TOTAL SHEETS
MA	XXX-XXXX(XXX)X	115	319
PROJECT FILE NO.		608164	

GRADING PLANS

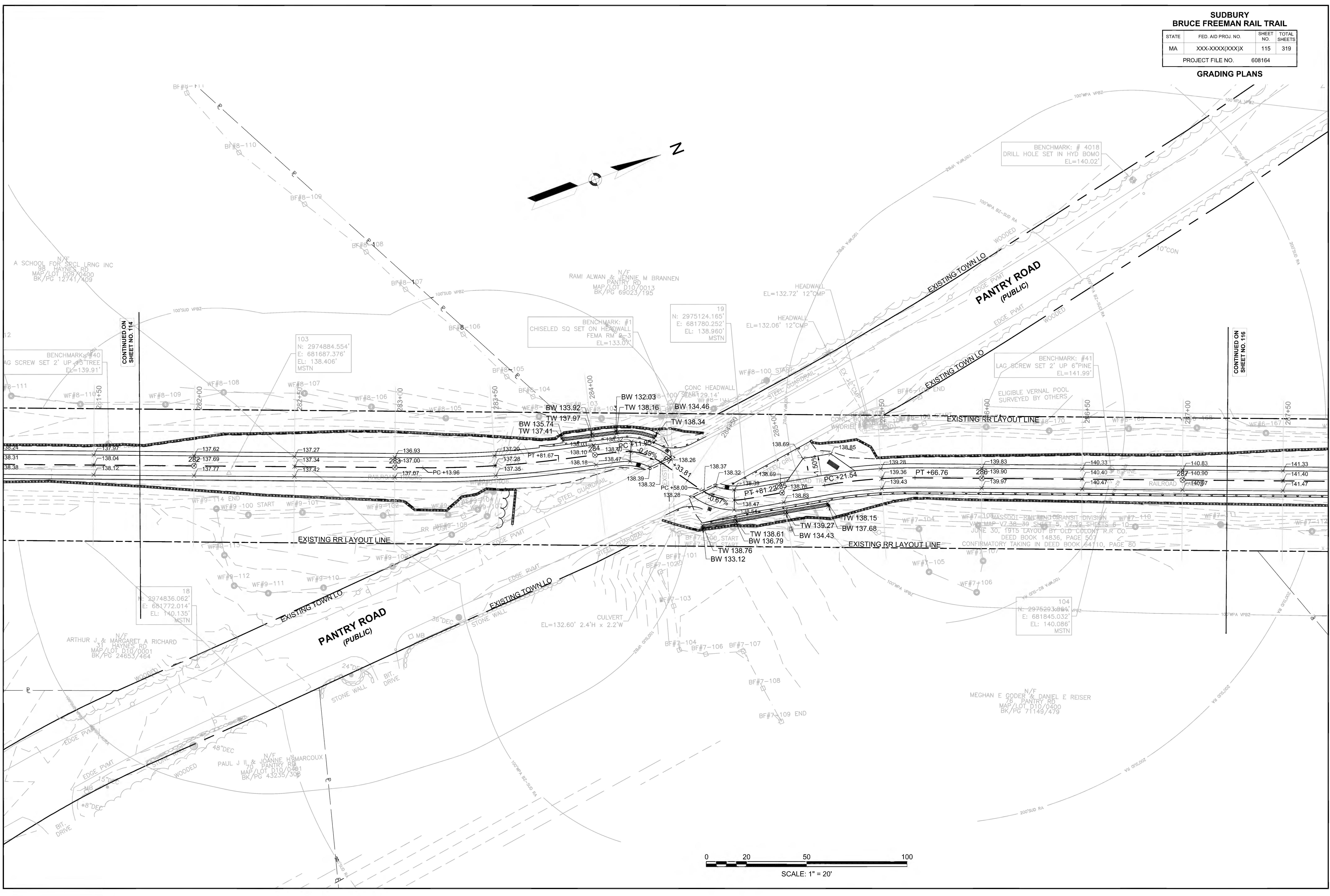

CONTINUED ON SHEET NO. 114

CONTINUED ON SHEET NO. 116

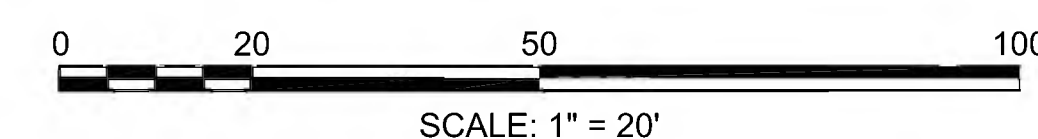

**SUDBURY
BRUCE FREEMAN RAIL TRAIL**

STATE	FED. AID PROJ. NO.	SHEET NO.	TOTAL SHEETS
MA	XXX-XXXX(XXX)X	116	319
PROJECT FILE NO.		608164	

GRADING PLANS

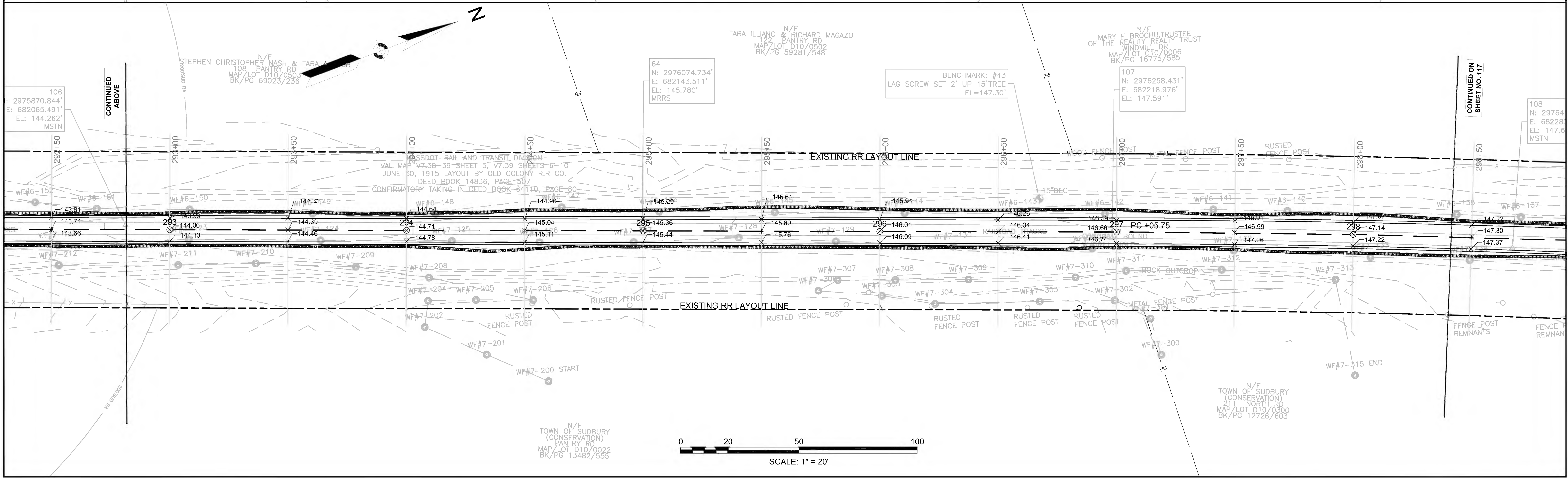
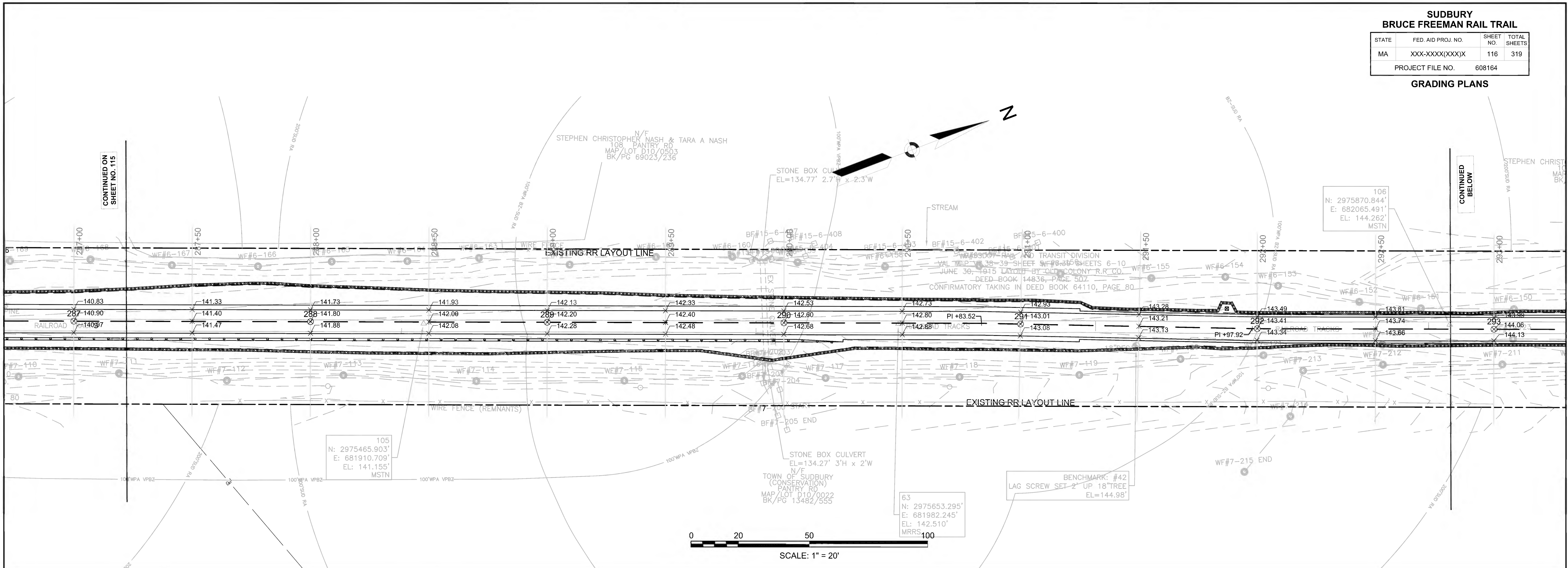

**SUDBURY
BRUCE FREEMAN RAIL TRAIL**

STATE	FED. AID PROJ. NO.	SHEET NO.	TOTAL SHEETS
MA	XXX-XXXX(XXX)X	117	319
PROJECT FILE NO.		608164	

GRADING PLANS

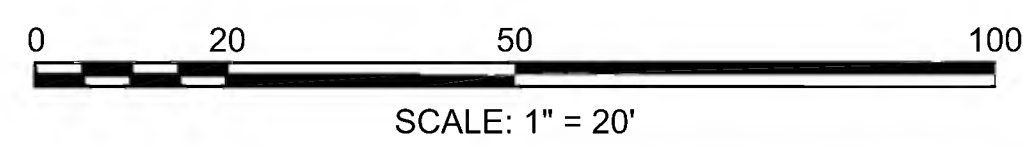
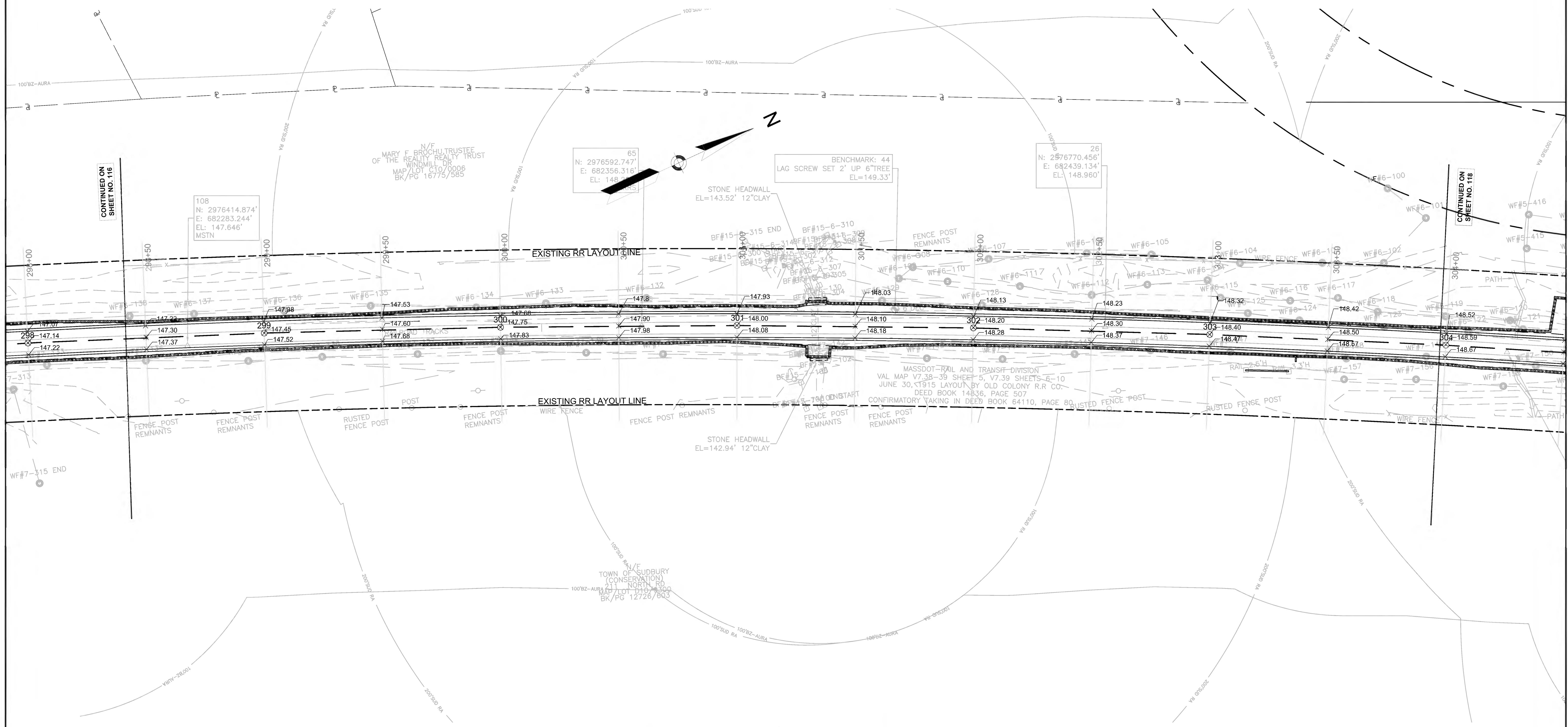

SUDBURY
BRUCE FREEMAN RAIL TRAIL

STATE	FED. AID PROJ. NO.	SHEET NO.	TOTAL SHEETS
MA	XXX-XXXX(XXX)X	118	319
PROJECT FILE NO.		608164	

GRADING PLANS

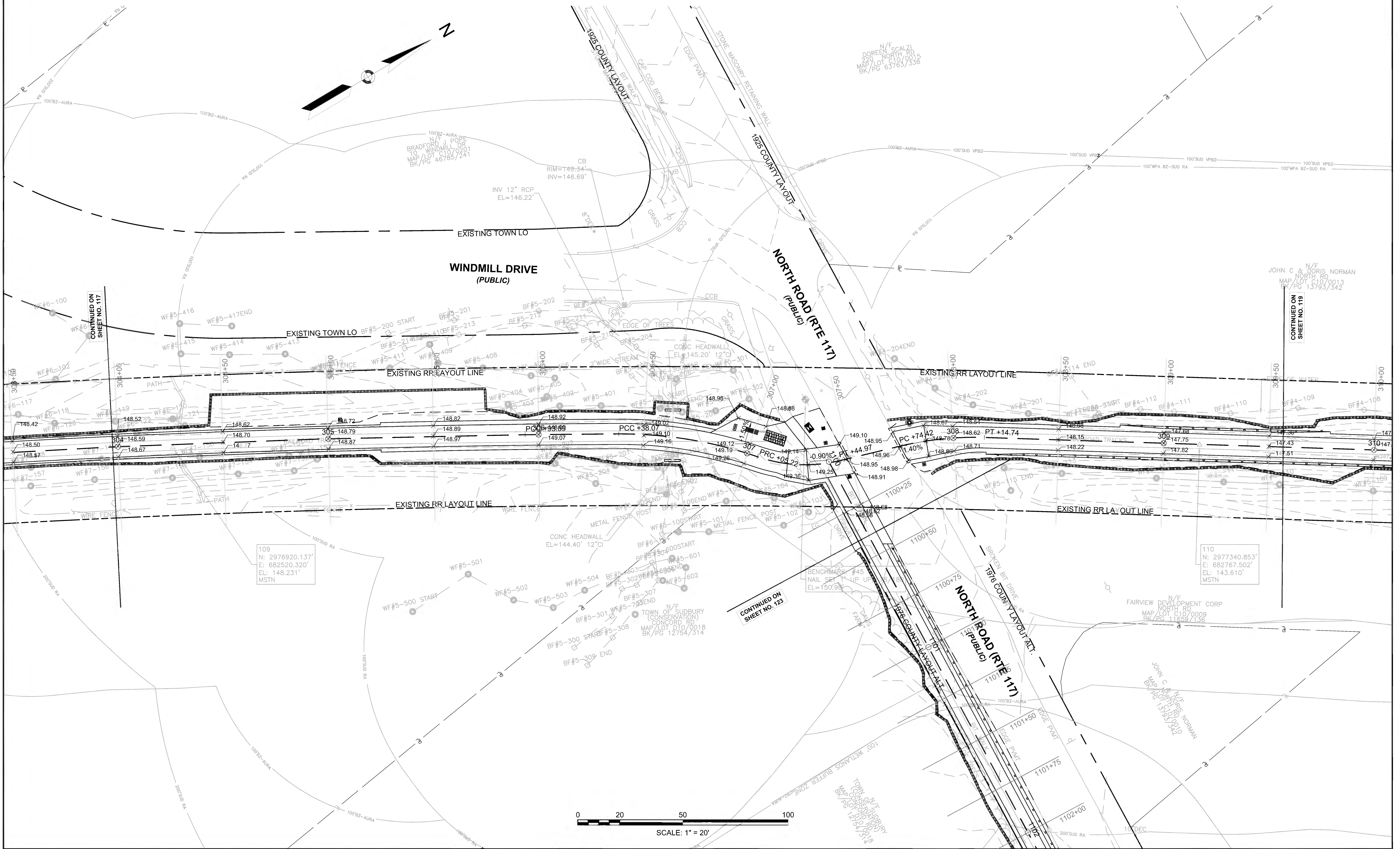

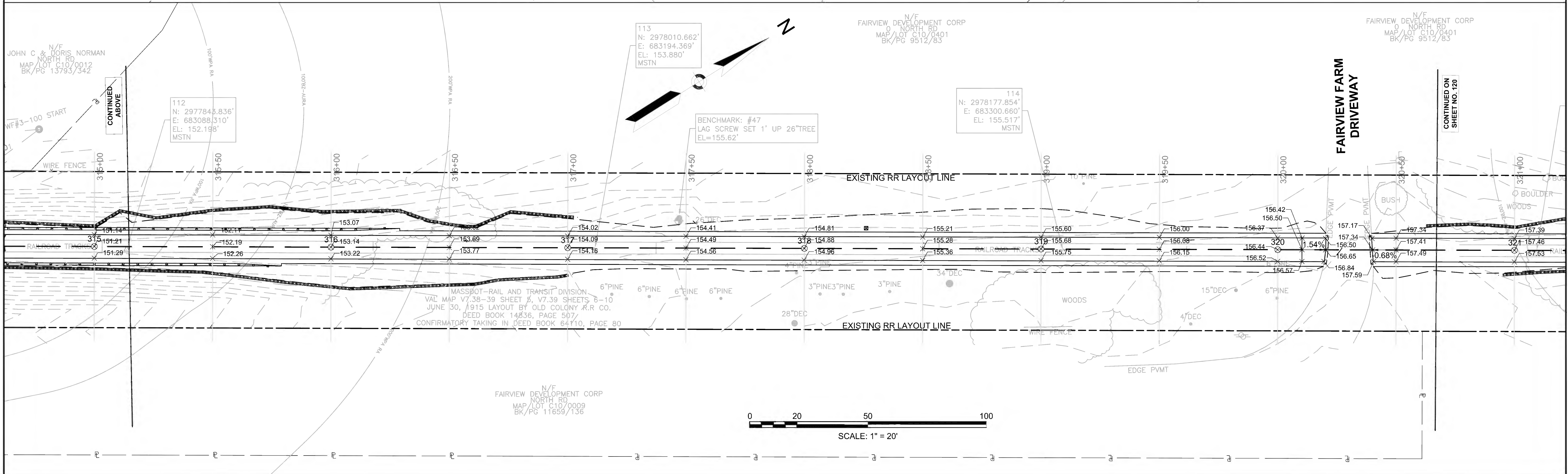
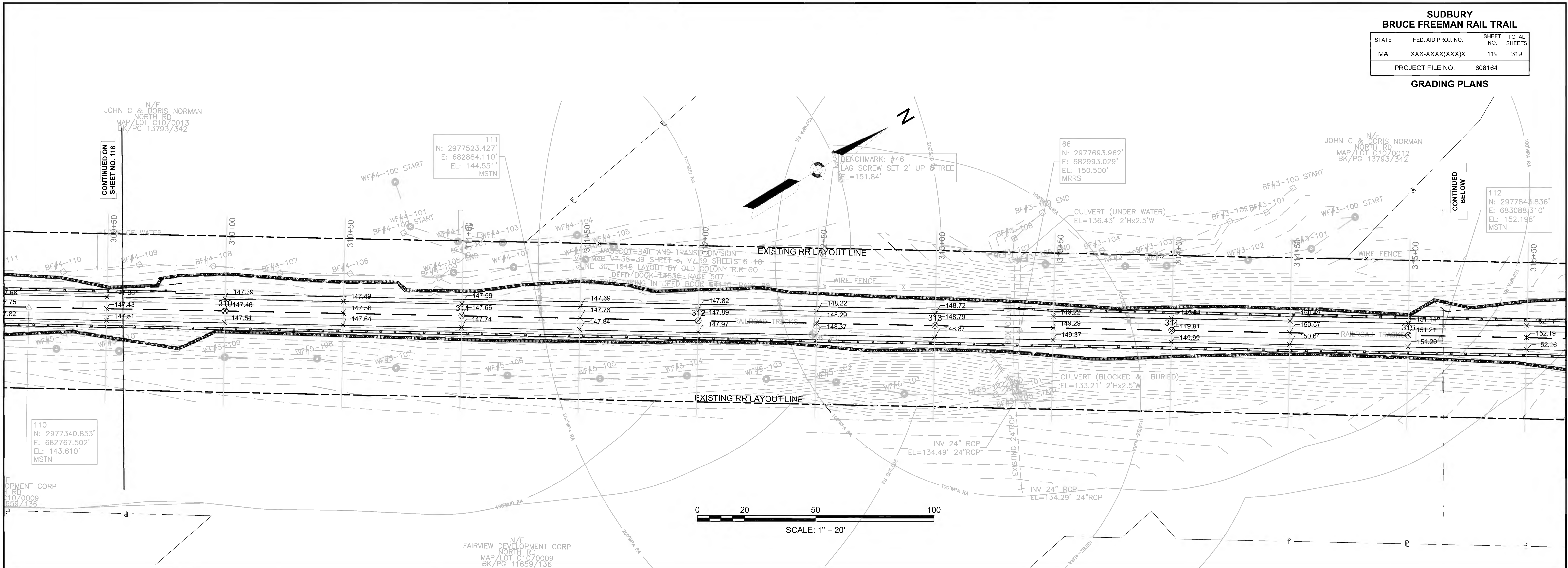

SUDBURY BRUCE FREEMAN RAIL TRAIL			
STATE	FED. AID PROJ. NO.	SHEET NO.	TOTAL SHEETS
MA	XXX-XXXX(XXX)X	120	319
PROJECT FILE NO.		608164	
GRADING PLANS			

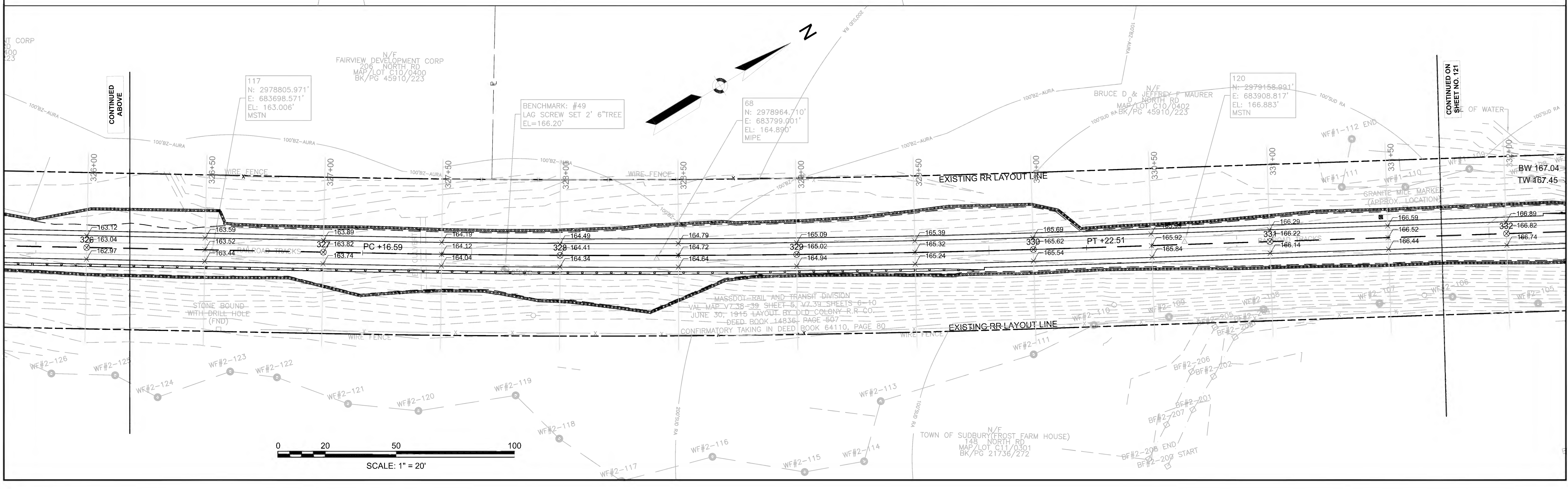
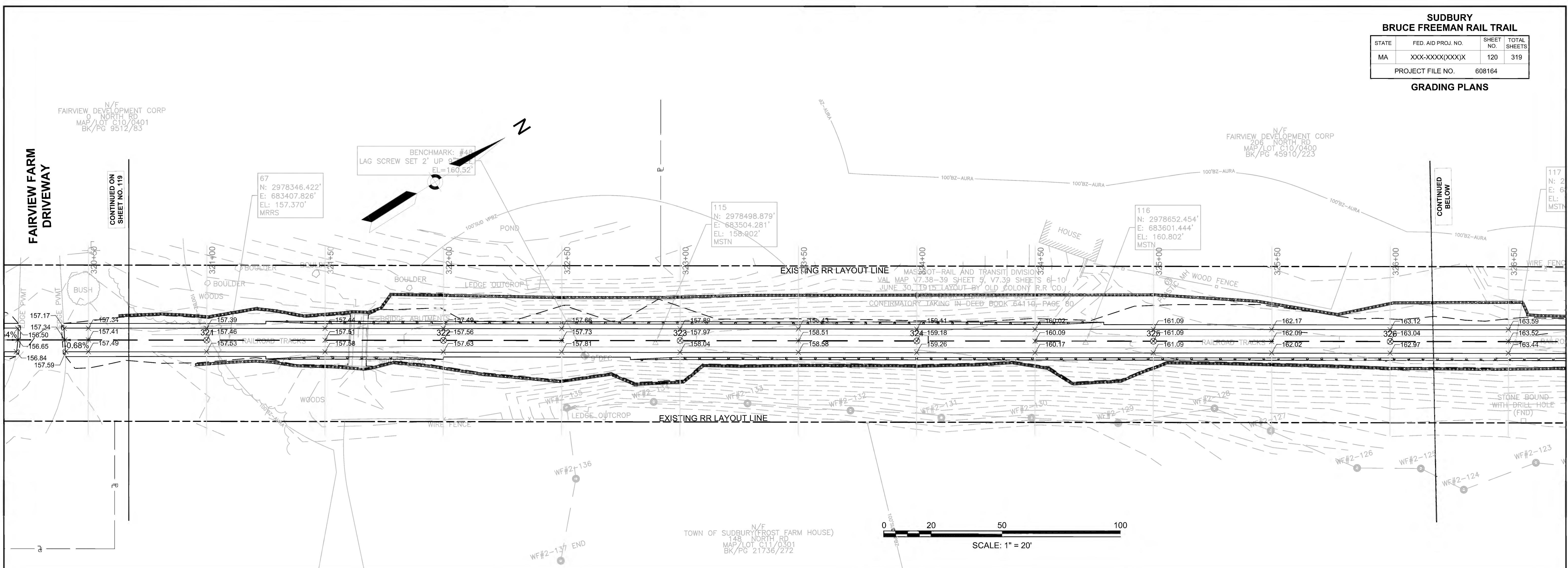

608164_HD(Grading Plans).DWG Plotted on 18-Feb-2022 4:05 PM

**SUDBURY
BRUCE FREEMAN RAIL TRAIL**

STATE	FED. AID PROJ. NO.	SHEET NO.	TOTAL SHEETS
MA	XXX-XXXX(XXX)X	121	319
PROJECT FILE NO.		608164	

GRADING PLANS

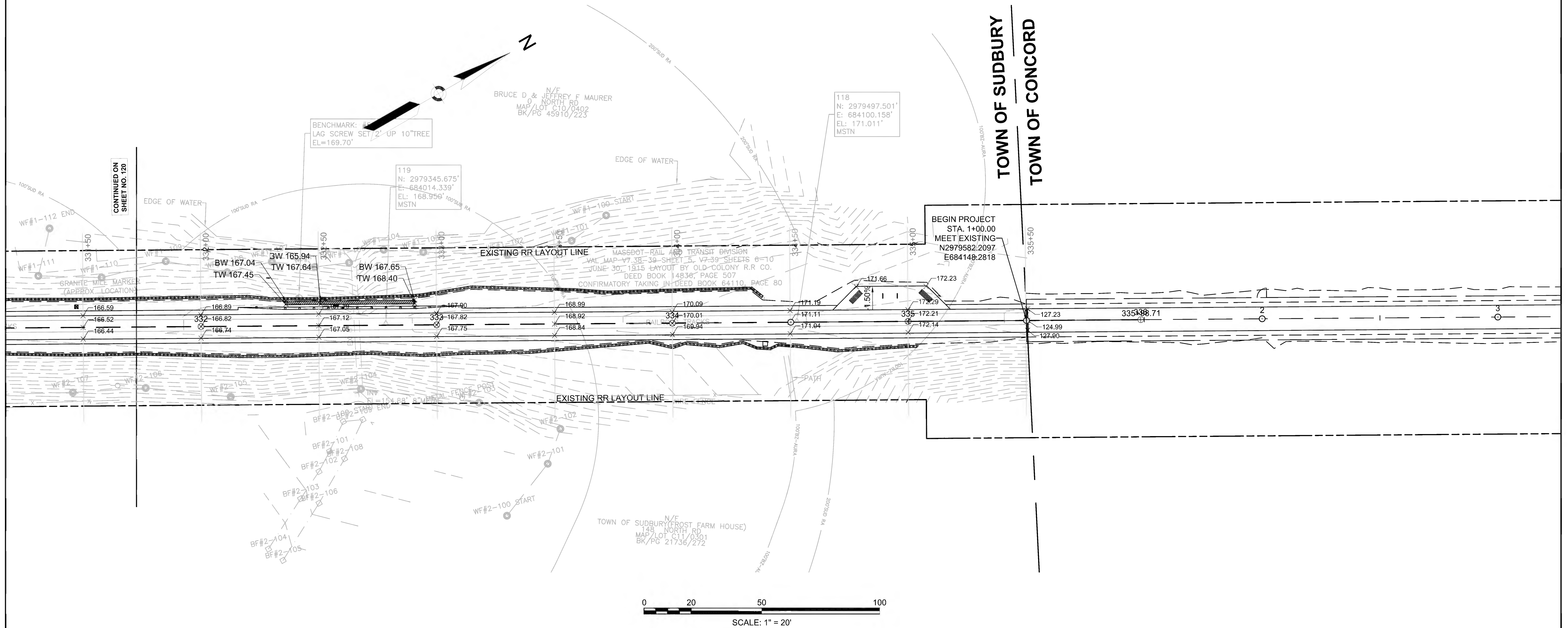

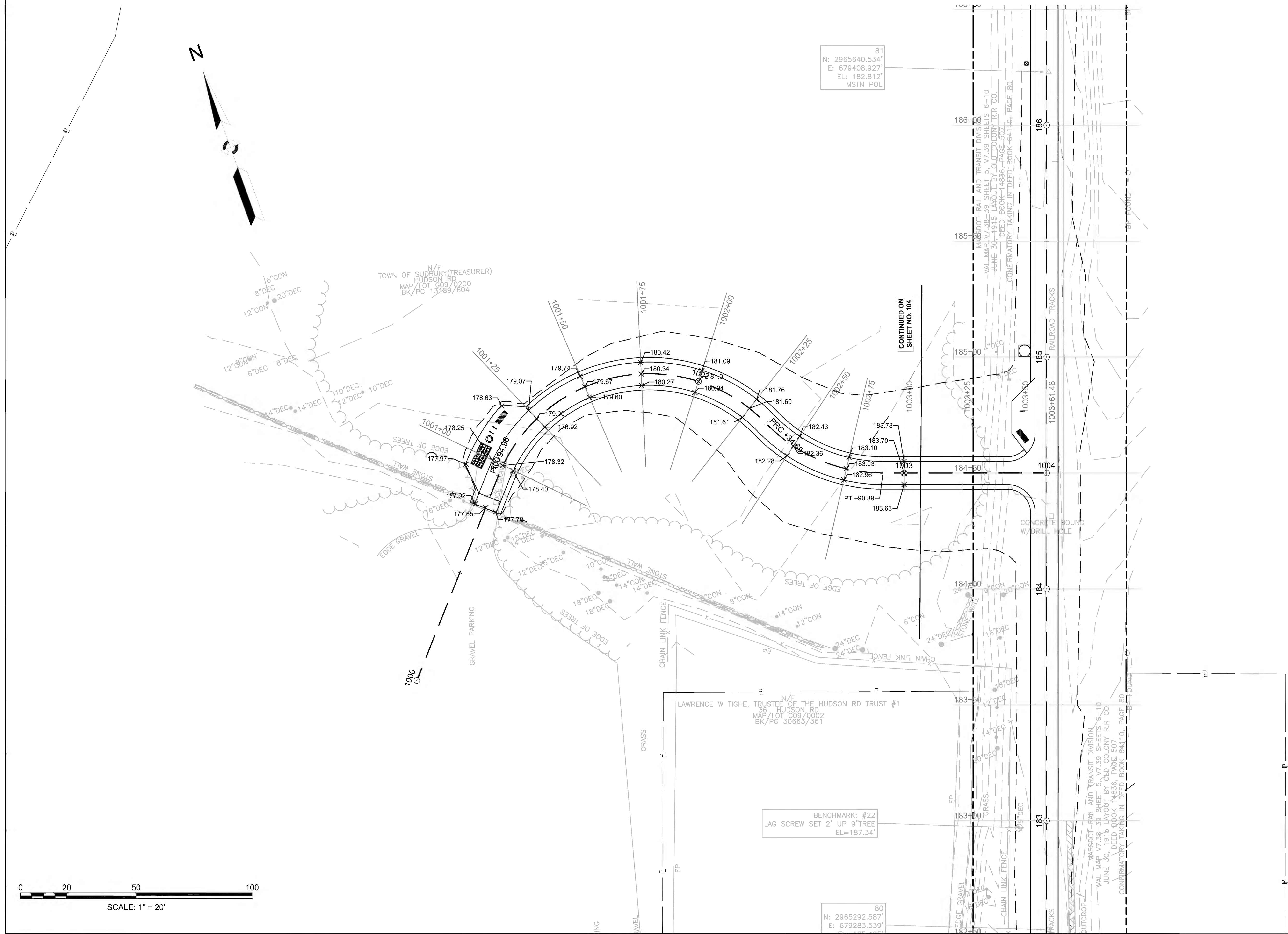

- DRAINAGE AND UTILITY NOTES:**
1. PROP. CONCRETE HEADWALLS SHALL CONFORM TO MASSDOT DETAIL E 206.4.0 & E 206.6.0.
 2. ALL CATCH BASIN FRAME AND GRATES TO BE MASSDOT CASCADE TYPE.

**SUDBURY
BRUCE FREEMAN RAIL TRAIL**

STATE	FED. AID PROJ. NO.	SHEET NO.	TOTAL SHEETS
MA	XXX-XXXX(XXX)X	174	319
PROJECT FILE NO.		608164	

DRAINAGE & UTILITY PLANS

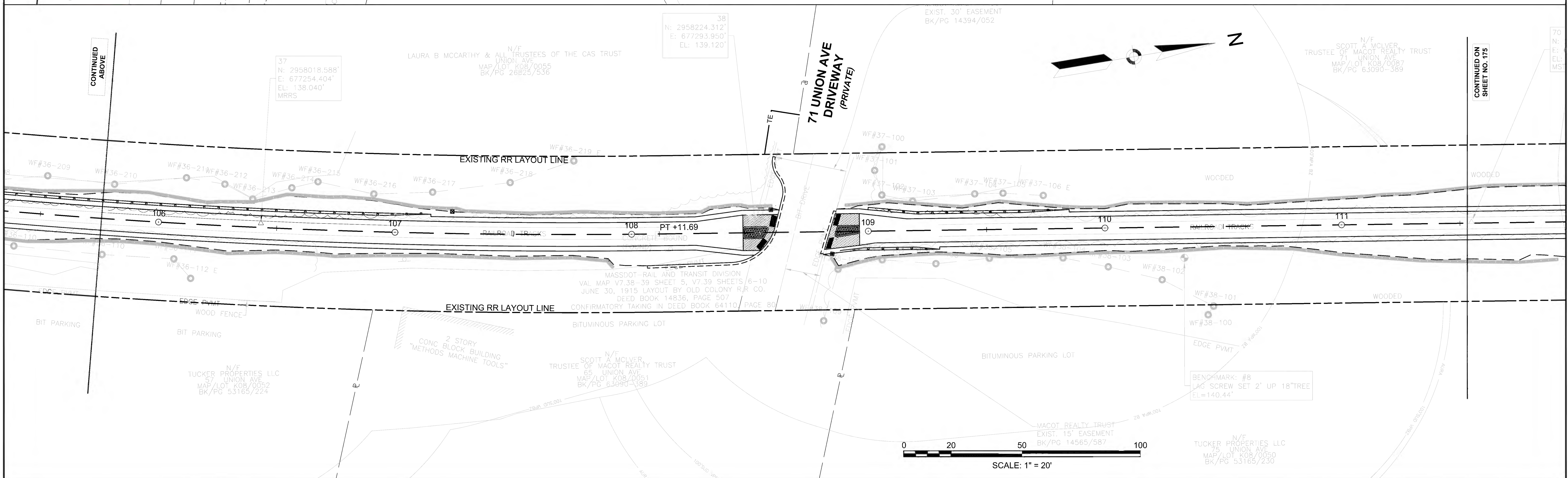
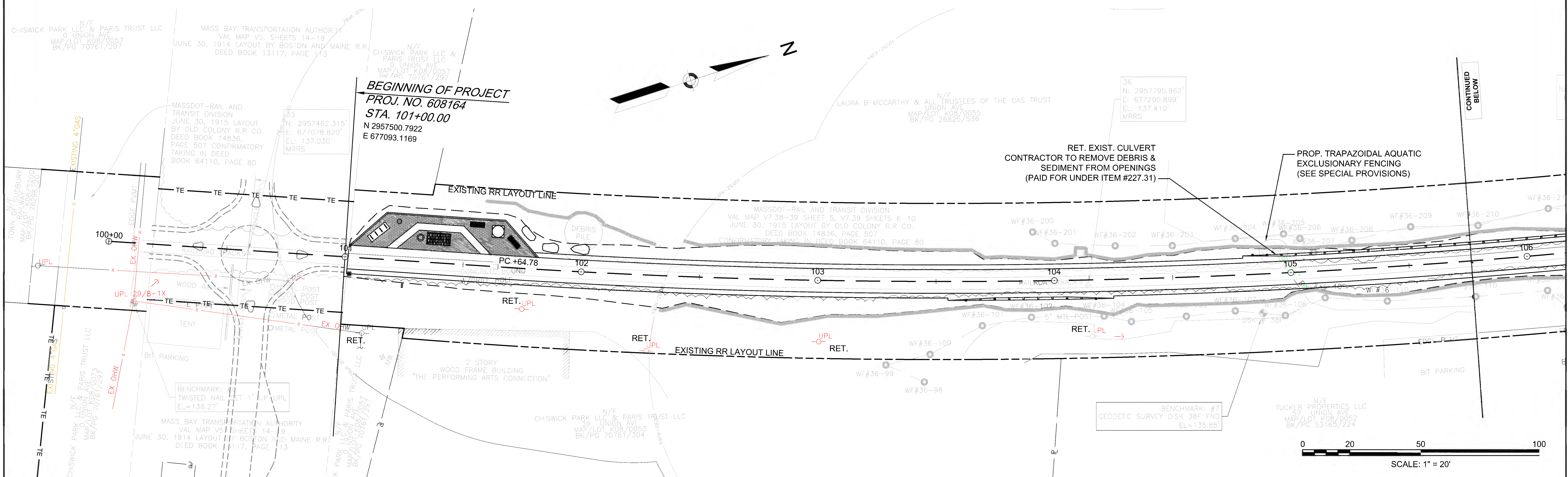

SUDBURY
BRUCE FREEMAN RAIL TRAIL

STATE	FED. AID PROJ. NO.	SHEET NO.	TOTAL SHEETS
MA	XXX-XXXX(XXX)X	175	319
PROJECT FILE NO.		608164	

DRAINAGE & UTILITY PLANS

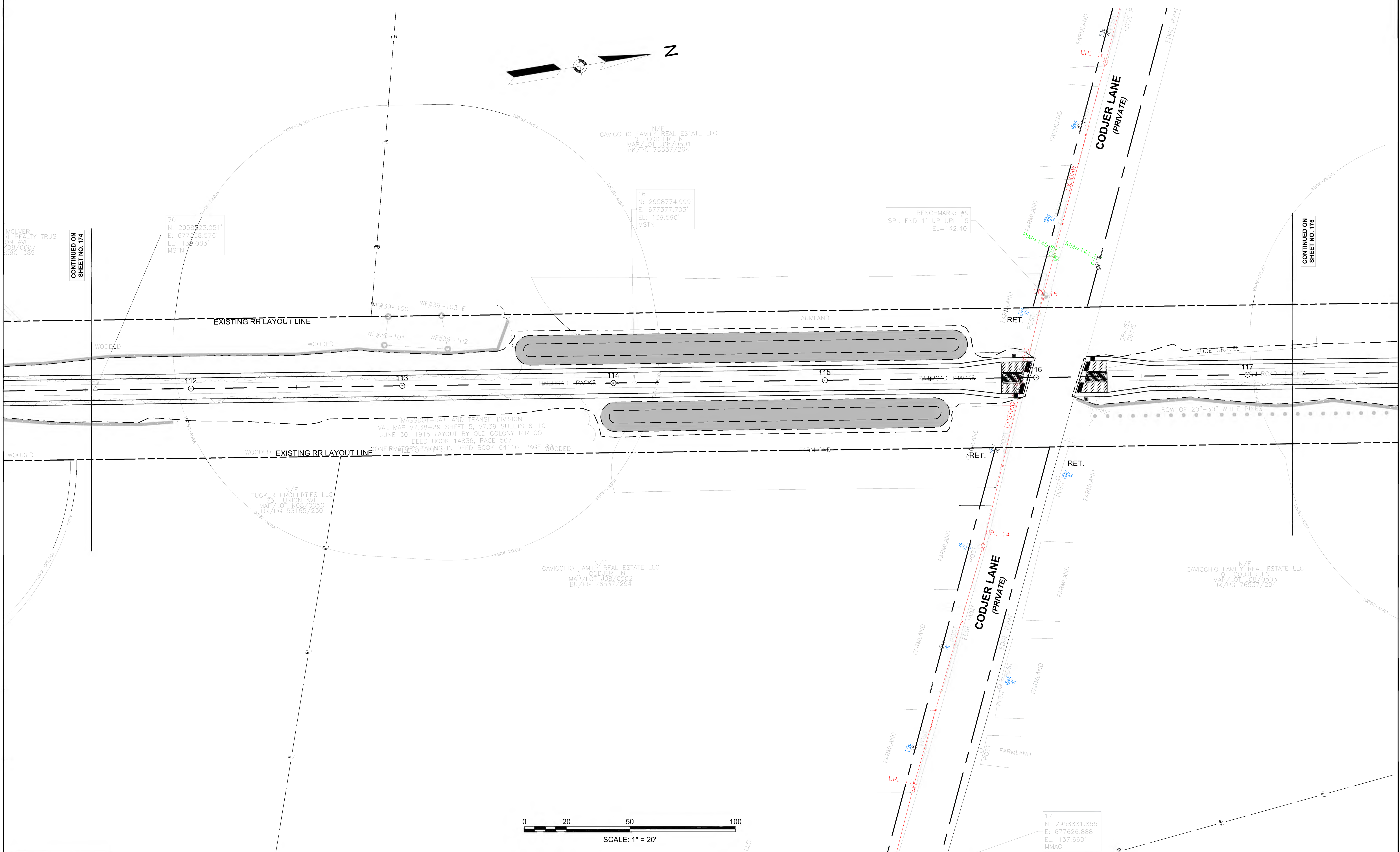
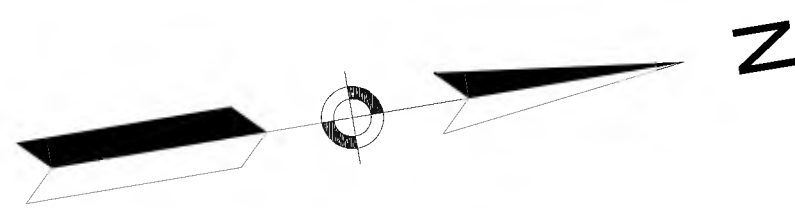

CONTINUED ON SHEET NO. 174

CONTINUED ON SHEET NO. 176

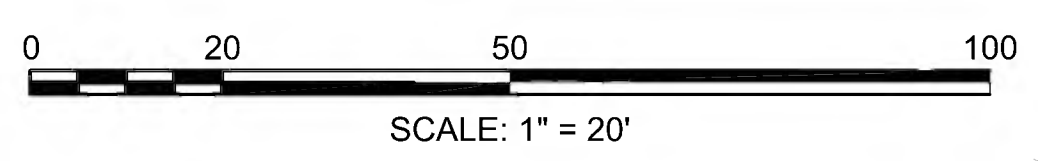

**SUDBURY
BRUCE FREEMAN RAIL TRAIL**

STATE	FED. AID PROJ. NO.	SHEET NO.	TOTAL SHEETS
MA	XXX-XXXX(XXX)X	176	319
PROJECT FILE NO.		608164	

DRAINAGE & UTILITY PLANS

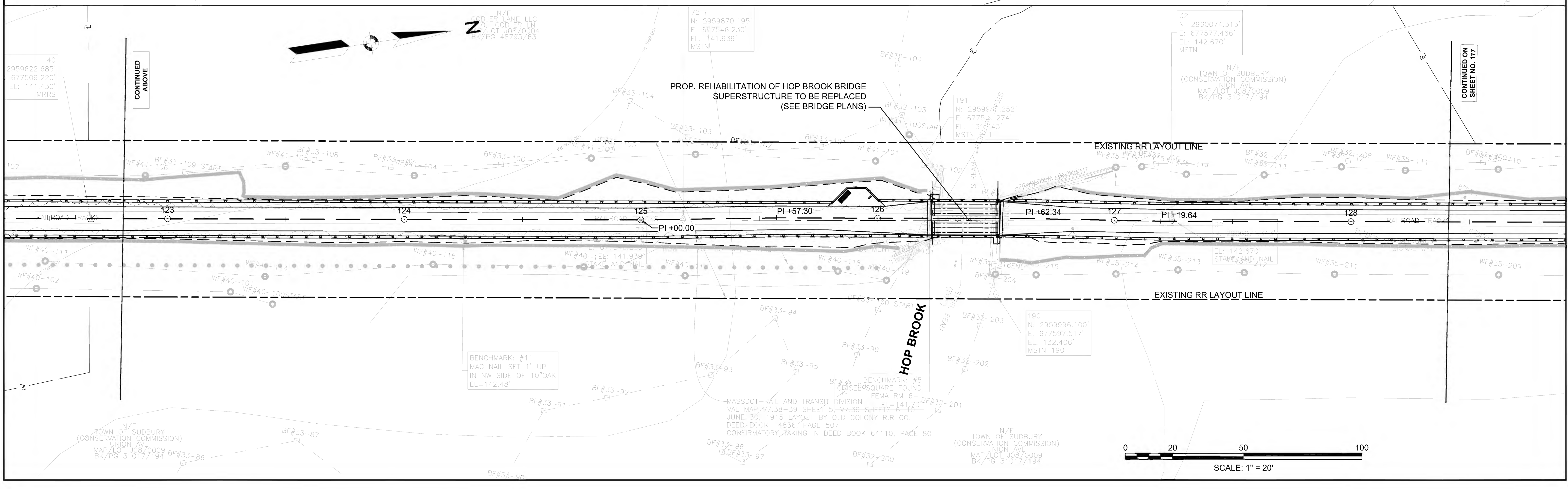
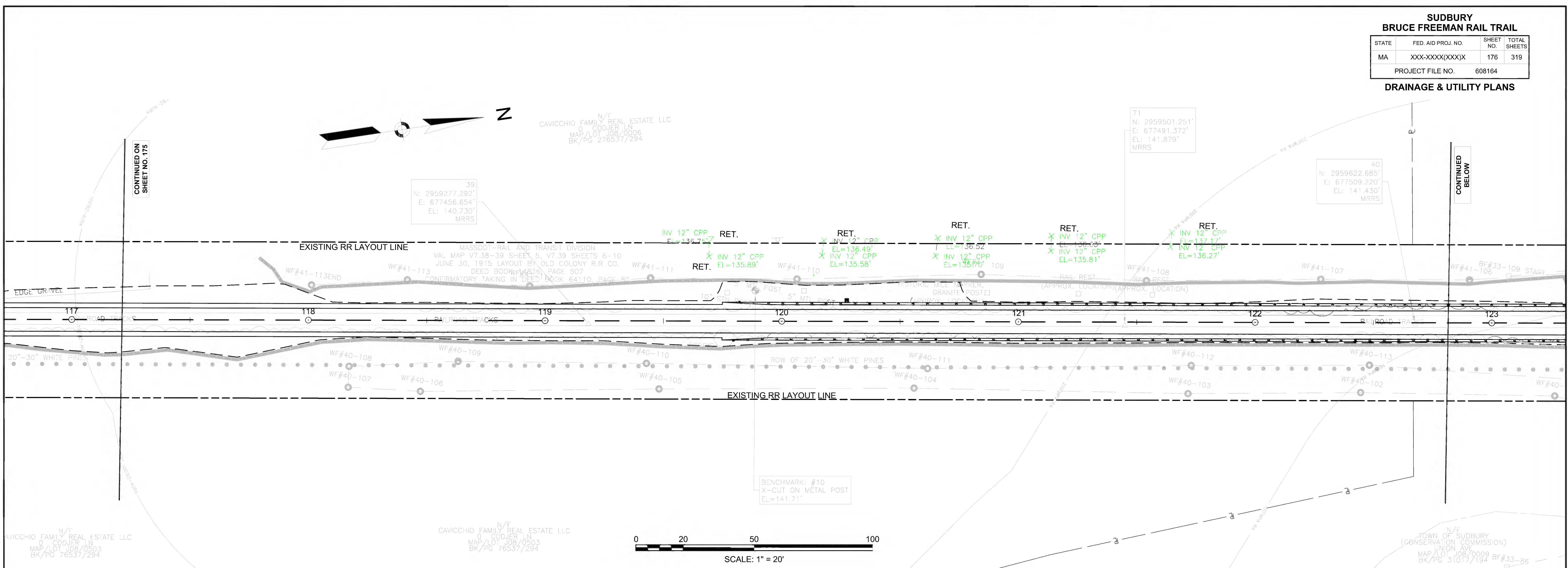

**SUDBURY
BRUCE FREEMAN RAIL TRAIL**

STATE	FED AID PROJ. NO.	SHEET NO.	TOTAL SHEETS
MA	XXX-XXXX(XXX)X	177	319
PROJECT FILE NO.		608164	

DRAINAGE & UTILITY PLANS

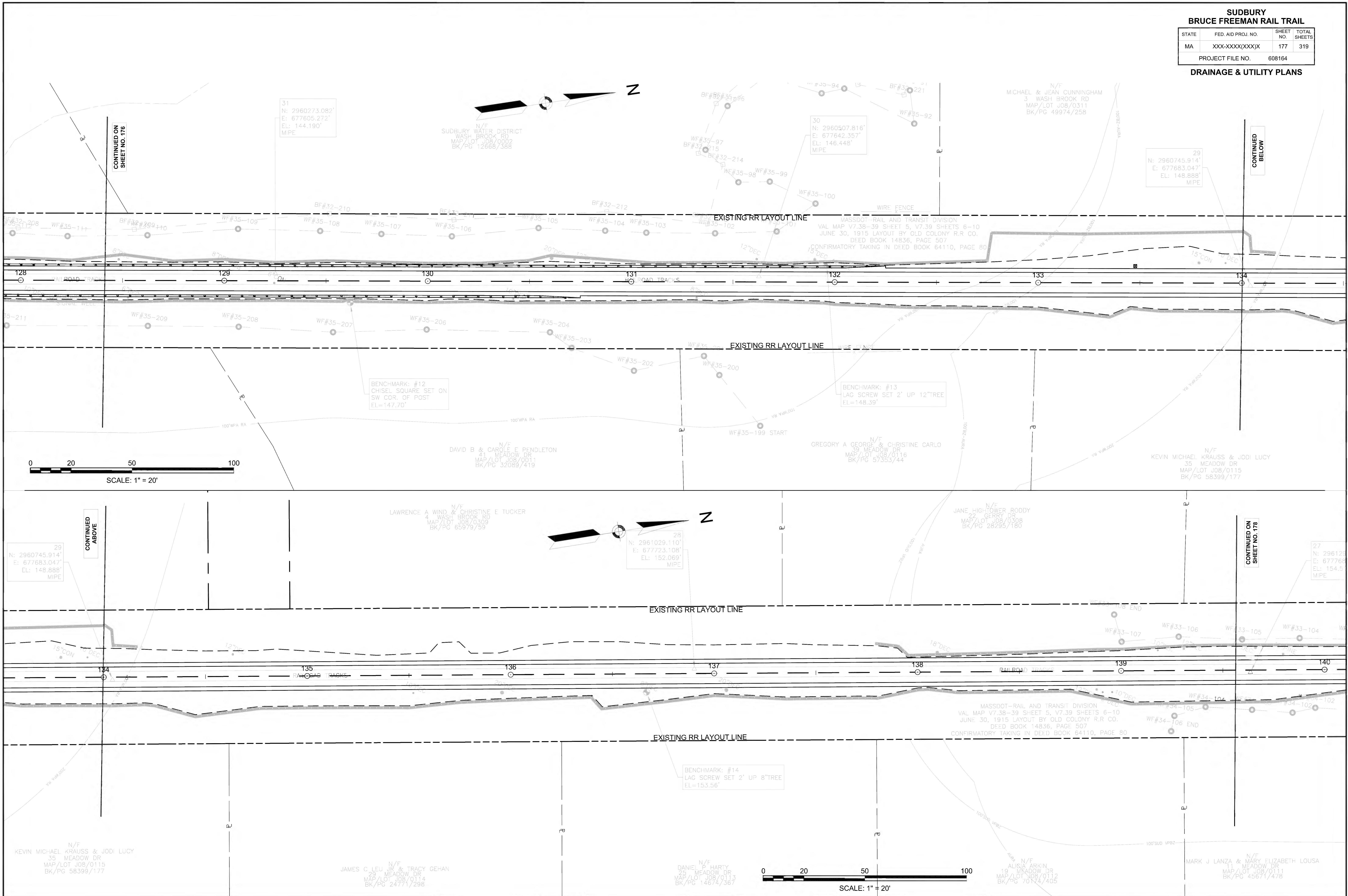

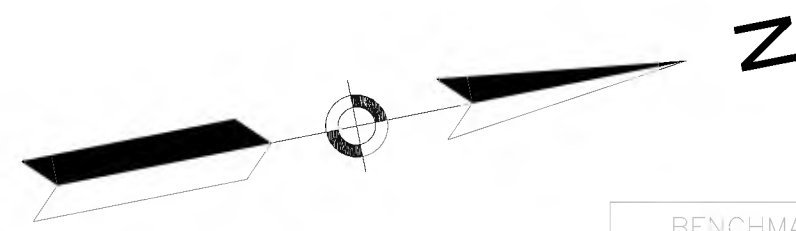

BENCHMARK: #66-11
 PK FOUND 1" UP IN UP
 EL=158.55'

2
 N: 2961684.439'
 E: 677666.655'
 EL: 156.229'
 MMAG

27
 N: 2961298.692'
 E: 677768.067'
 EL: 154.519'
 MIPE

BENCHMARK: #15
 LAG NAIL SET 2' UP 10" TREE
 EL=158.72'

3
 N: 2961644.458'
 E: 677817.347'
 EL: 159.339'
 MMAG

N/F
 MARCELLO C SANTANA
 226 OLD LANCASTER RD
 MAP/LOT 108/0045
 BK/PG 75814/51

N/F
 MATTHEW P & KENDRA H DOYON
 220 OLD LANCASTER RD
 MAP/LOT 108/0019
 BK/PG 71206/253

N/F
 JOSHUA R & VICTORIA A BARIBEAU
 219 OLD LANCASTER RD
 MAP/LOT 108/0102
 BK/PG 55651/169

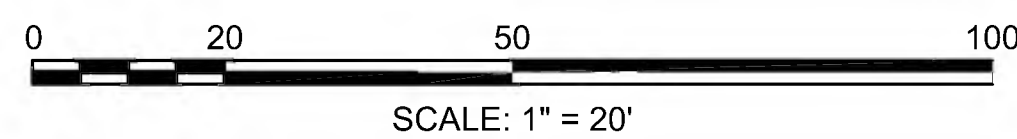

CONTINUED ON
SHEET NO. 177

CONTINUED ON
SHEET NO. 179

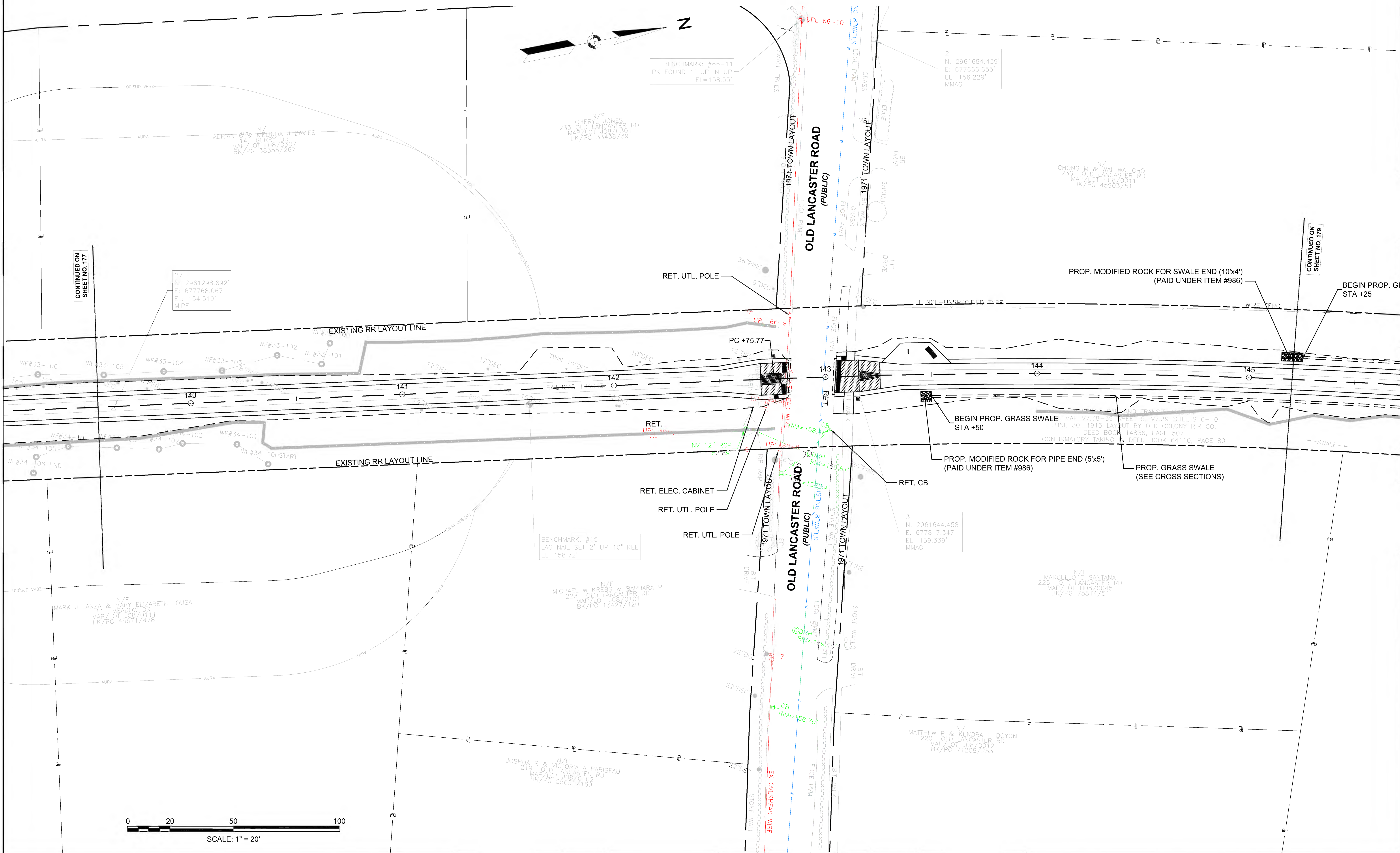

**SUDBURY
BRUCE FREEMAN RAIL TRAIL**

STATE	FED. AID PROJ. NO.	SHEET NO.	TOTAL SHEETS
MA	XXX-XXXX(XXX)X	179	319

PROJECT FILE NO. 608164

DRAINAGE & UTILITY PLANS

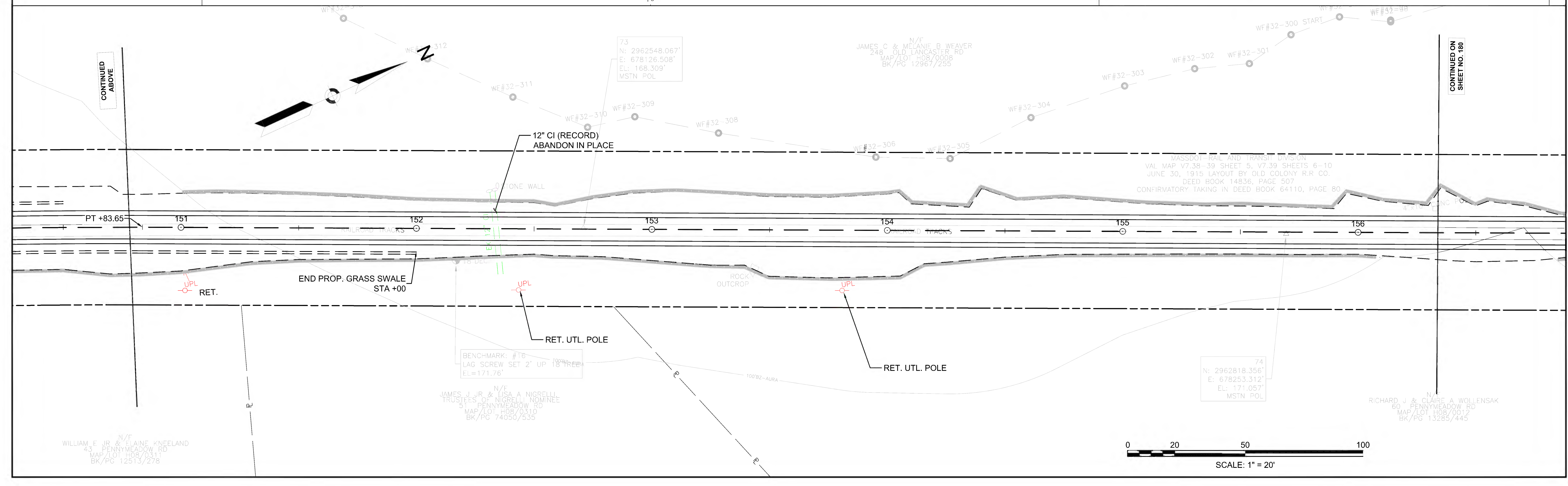
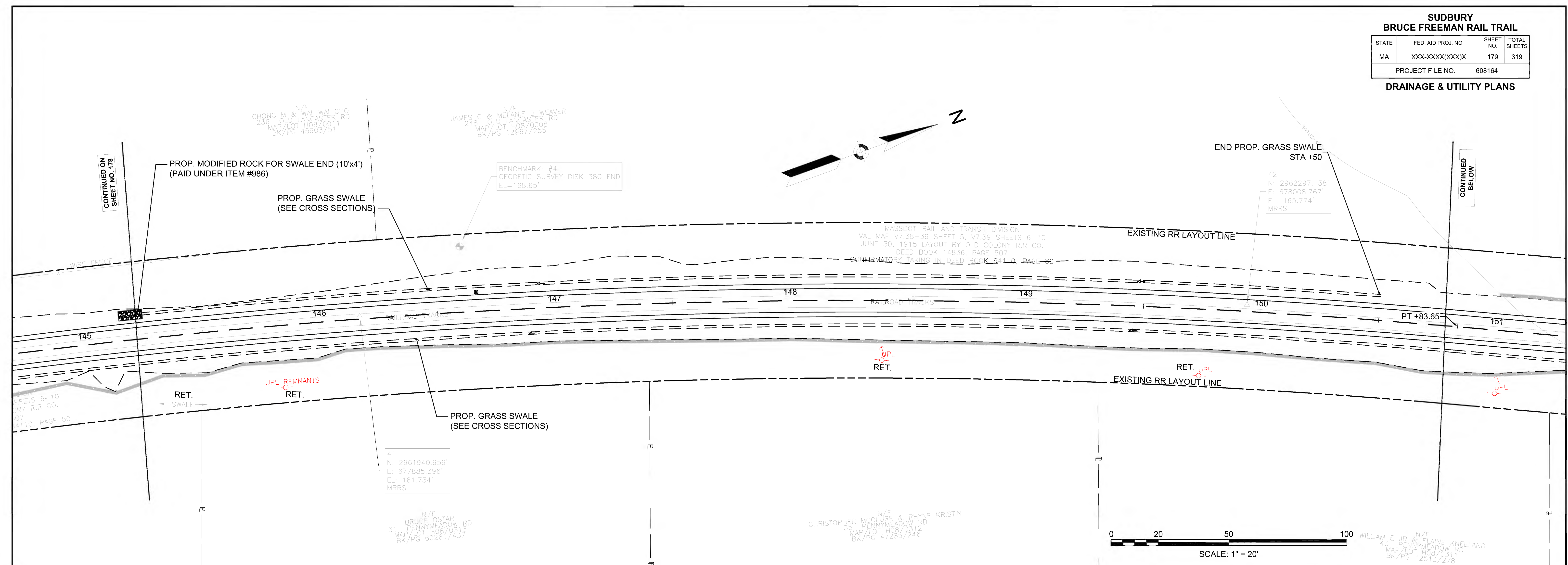

608164_H0(DRAINAGE & UTILITY PLANS).DWG Plotted on 18-Feb-2022 4:13 PM

**SUDBURY
BRUCE FREEMAN RAIL TRAIL**

STATE	FED. AID PROJ. NO.	SHEET NO.	TOTAL SHEETS
MA	XXX-XXXX(XXX)X	181	319
PROJECT FILE NO.		608164	

DRAINAGE & UTILITY PLANS

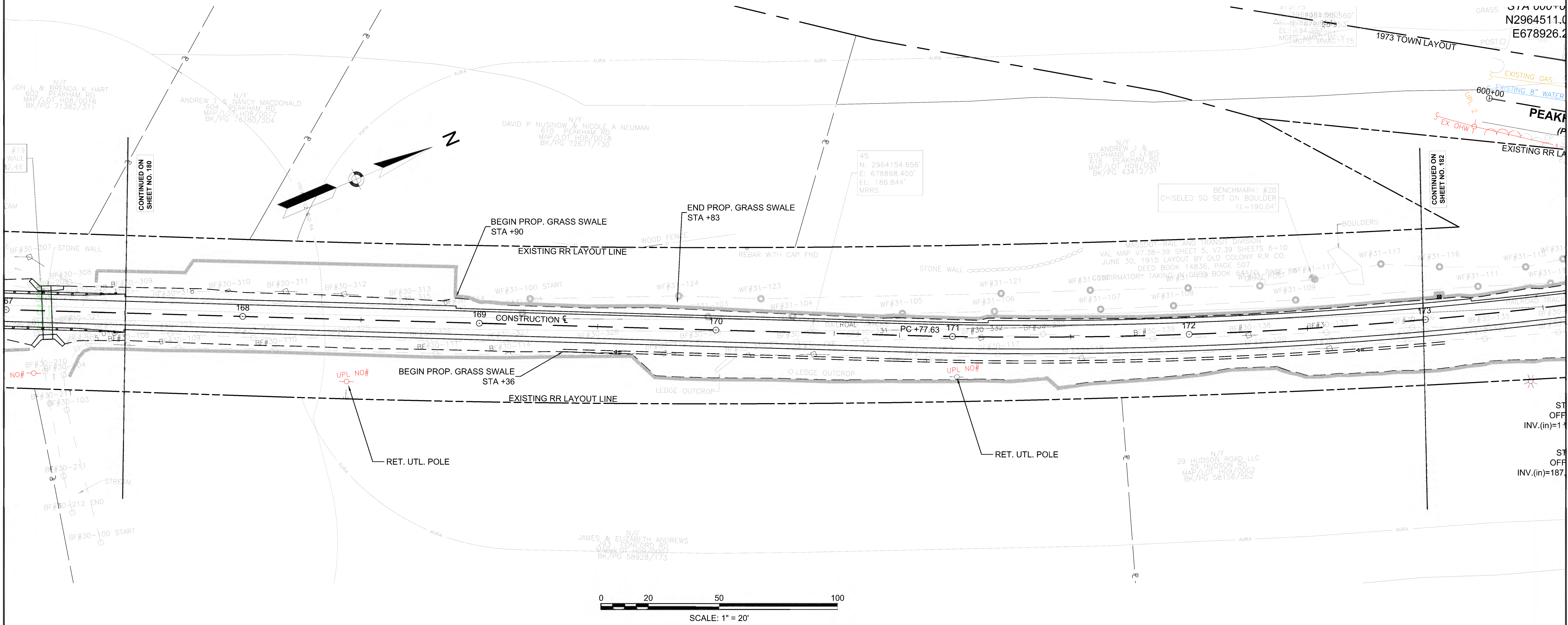

608164_H01DRAINAGE & UTILITY PLANS.DWG Plotted on 18-Feb-2022 4:14 PM

NOTE:
1. ALL EXISTING UNDERGROUND UTILITIES ARE TO BE RETAINED.

SUDBURY BRUCE FREEMAN RAIL TRAIL			
STATE	FED. AID PROJ. NO.	SHEET NO.	TOTAL SHEETS
MA	XXX-XXXX(XXX)X	182	319
PROJECT FILE NO.		608164	
DRAINAGE & UTILITY PLANS			

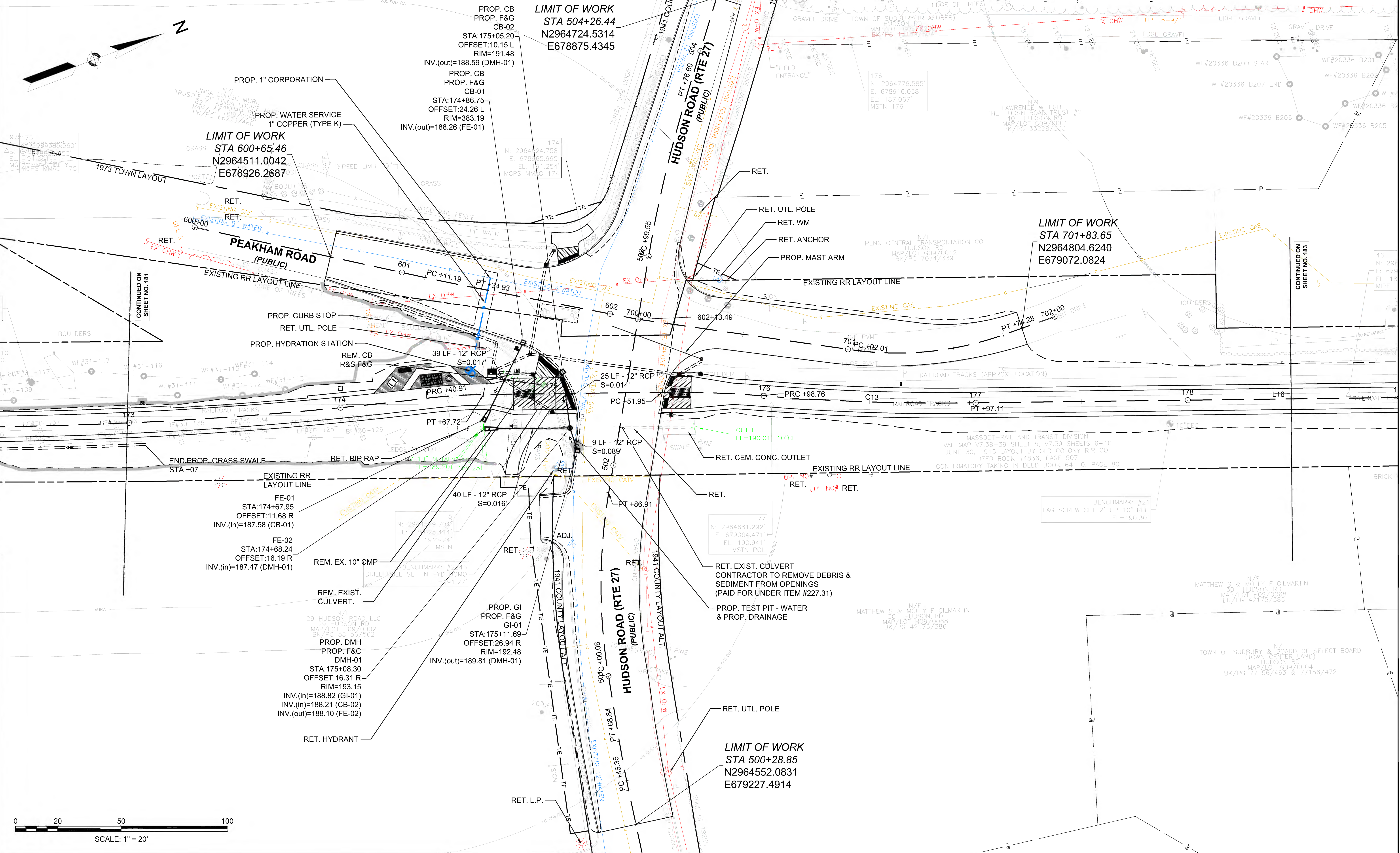

PROP. 1" CORPORATION
PROP. WATER SERVICE
1" COPPER (TYPE K)
LIMIT OF WORK
STA 600+65.46
N2964511.0042
E678926.2687

PROP. CB
PROP. F&G
CB-02
STA:175+05.20
OFFSET:10.15 L
RIM=191.48
INV.(out)=188.59 (DMH-01)
PROP. CB
PROP. F&G
CB-01
STA:174+86.75
OFFSET:24.26 L
RIM=383.19
INV.(out)=188.26 (FE-01)

LIMIT OF WORK
STA 504+26.44
N2964724.5314
E678875.4345

LIMIT OF WORK
STA 701+83.65
N2964804.6240
E679072.0824

LIMIT OF WORK
STA 500+28.85
N2964552.0831
E679227.4914

CONTINUED ON
SHEET NO. 181

CONTINUED ON
SHEET NO. 183

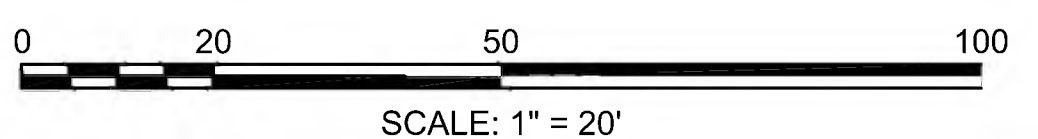

**SUDBURY
BRUCE FREEMAN RAIL TRAIL**

STATE	FED. AID PROJ. NO.	SHEET NO.	TOTAL SHEETS
MA	XXX-XXXX(XXX)X	183	319
PROJECT FILE NO.		608164	

DRAINAGE & UTILITY PLANS

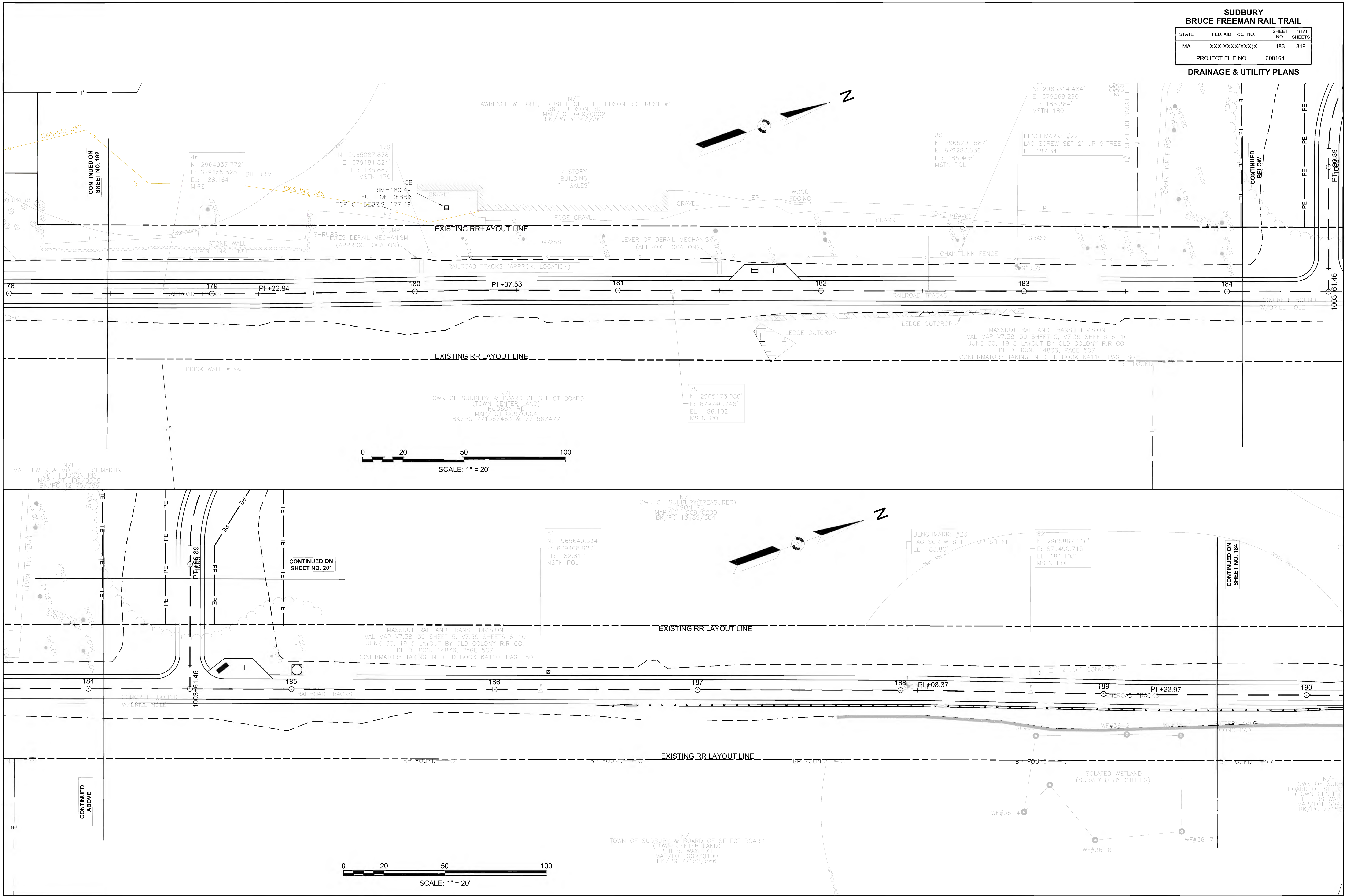

**SUDBURY
BRUCE FREEMAN RAIL TRAIL**

STATE	FED. AID PROJ. NO.	SHEET NO.	TOTAL SHEETS
MA	XXX-XXXX(XXX)X	185	319
PROJECT FILE NO.		608164	

DRAINAGE & UTILITY PLANS

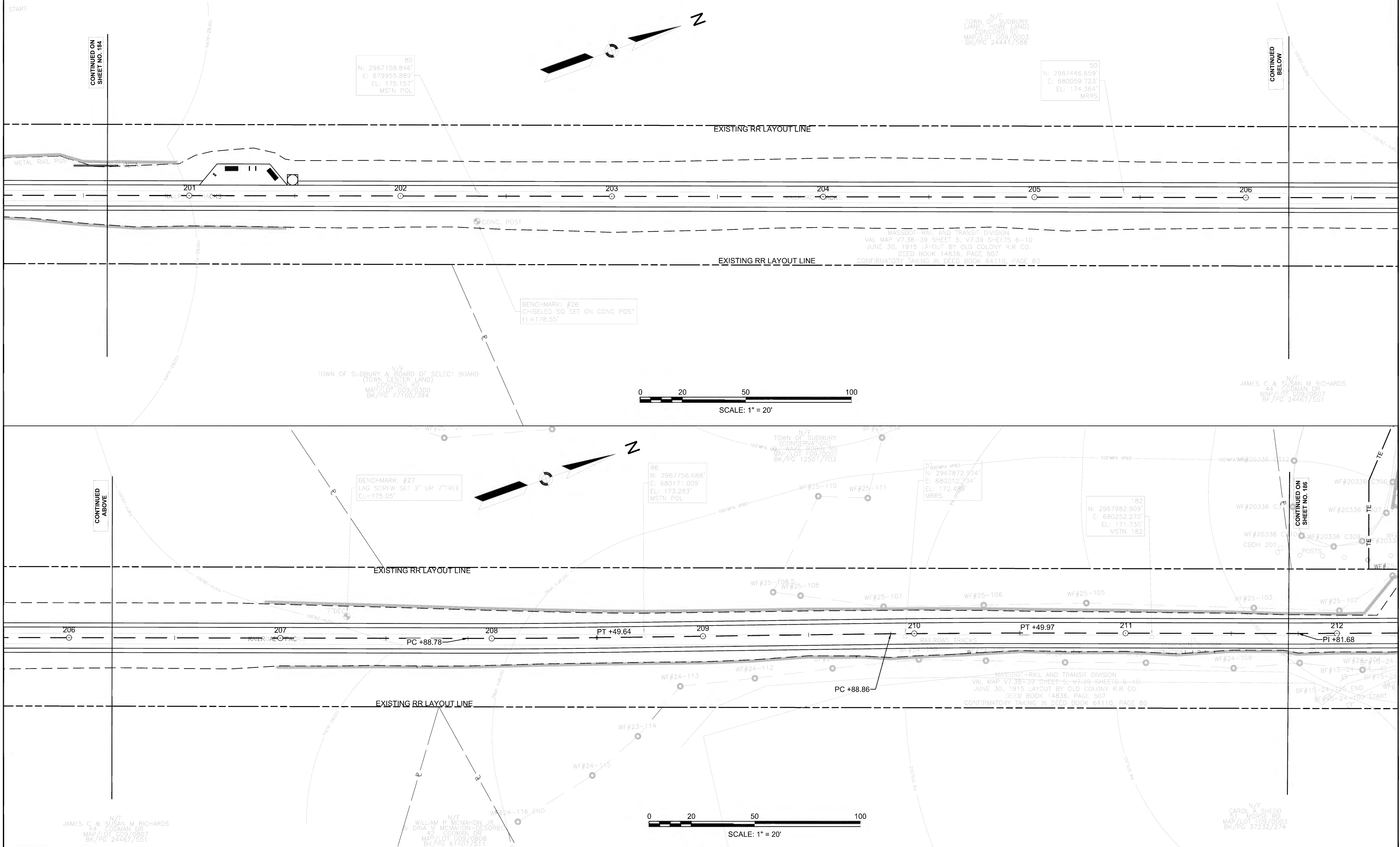

CONTINUED ON
SHEET NO. 184

CONTINUED
BELOW

CONTINUED
ABOVE

CONTINUED ON
SHEET NO. 186

N/F
TOWN OF SUDBURY
(JANE) (LOW LAND)
CONCORD RD
MAP/LOT 099/0003
BK/PG 24441/588

N/F
TOWN OF SUDBURY & BOARD OF SELECT BOARD
(TOWN CENTER LAND)
CONCORD RD
MAP/LOT 009/0300
BK/PG 77160/394

N/F
TOWN OF SUDBURY
(CONSERVATION)
WADSWORTH RD
MAP/LOT F09/0001
BK/PG 12501/703

N/F
JAMES C. & SUSAN M. RICHARDS
44 CODMAN DR
MAP/LOT 008/0617
BK/PG 24467/551

N/F
JAMES C. & SUSAN M. RICHARDS
44 CODMAN DR
MAP/LOT 009/0807
BK/PG 24467/551

N/F
WILLIAM P. MCMAHON JR.
& DINA V. MCMAHON-DESOREL
42 CODMAN DR
MAP/LOT 009/0808
BK/PG 61407/511

N/F
CAROL A. SHEDD
51 MORSE RD
MAP/LOT 109/0003
BK/PG 37232/274

MASSDOT-RAIL AND TRANSIT DIVISION
VAL MAP V7.38-39 SHEET 5, V7.39 SHEETS 6-10
JUNE 30, 1915 LAYOUT BY OLD COLONY R.R. CO.
DEED BOOK 14836, PAGE 507
CONFIRMATORY TAKING IN DEED BOOK 64110, PAGE 80

MASSDOT-RAIL AND TRANSIT DIVISION
VAL MAP V7.38-39 SHEET 5, V7.39 SHEETS 6-10
JUNE 30, 1915 LAYOUT BY OLD COLONY R.R. CO.
DEED BOOK 14836, PAGE 507
CONFIRMATORY TAKING IN DEED BOOK 64110, PAGE 80

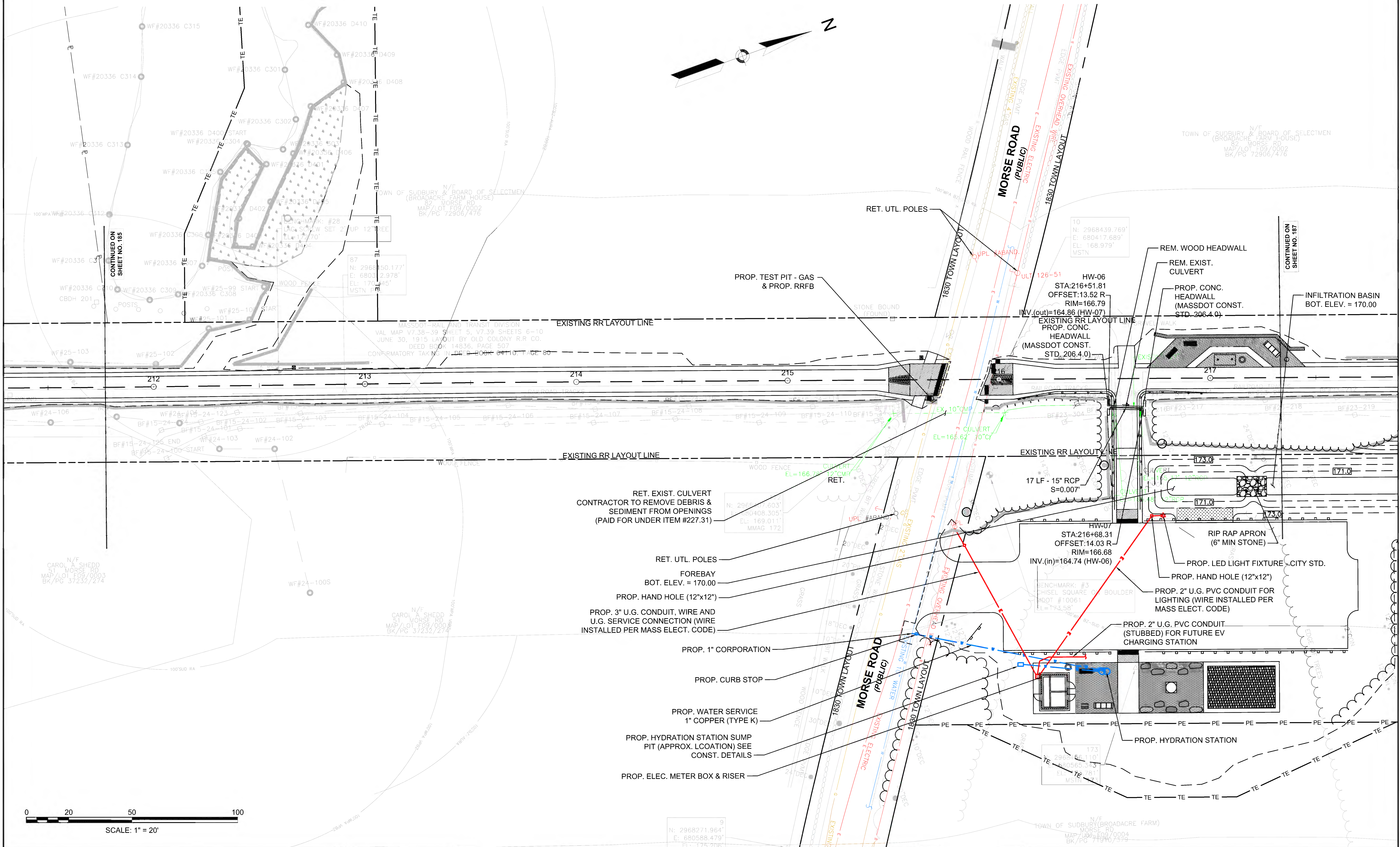

**SUDBURY
BRUCE FREEMAN RAIL TRAIL**

STATE	FED. AID PROJ. NO.	SHEET NO.	TOTAL SHEETS
MA	XXX-XXXX(XXX)X	187	319
PROJECT FILE NO.		608164	

DRAINAGE & UTILITY PLANS

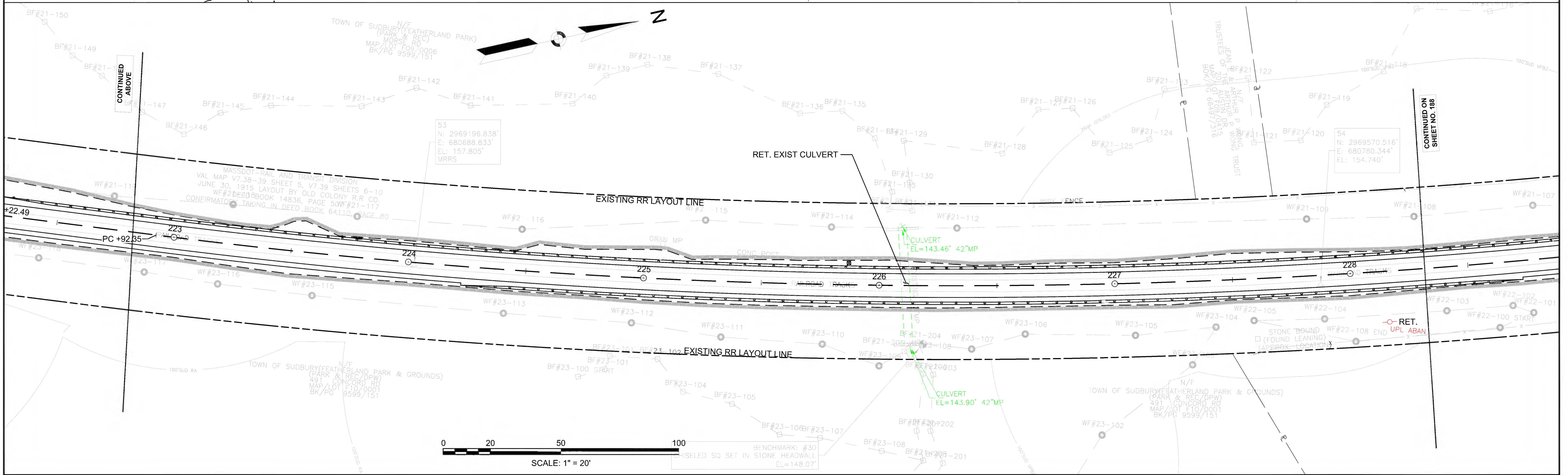
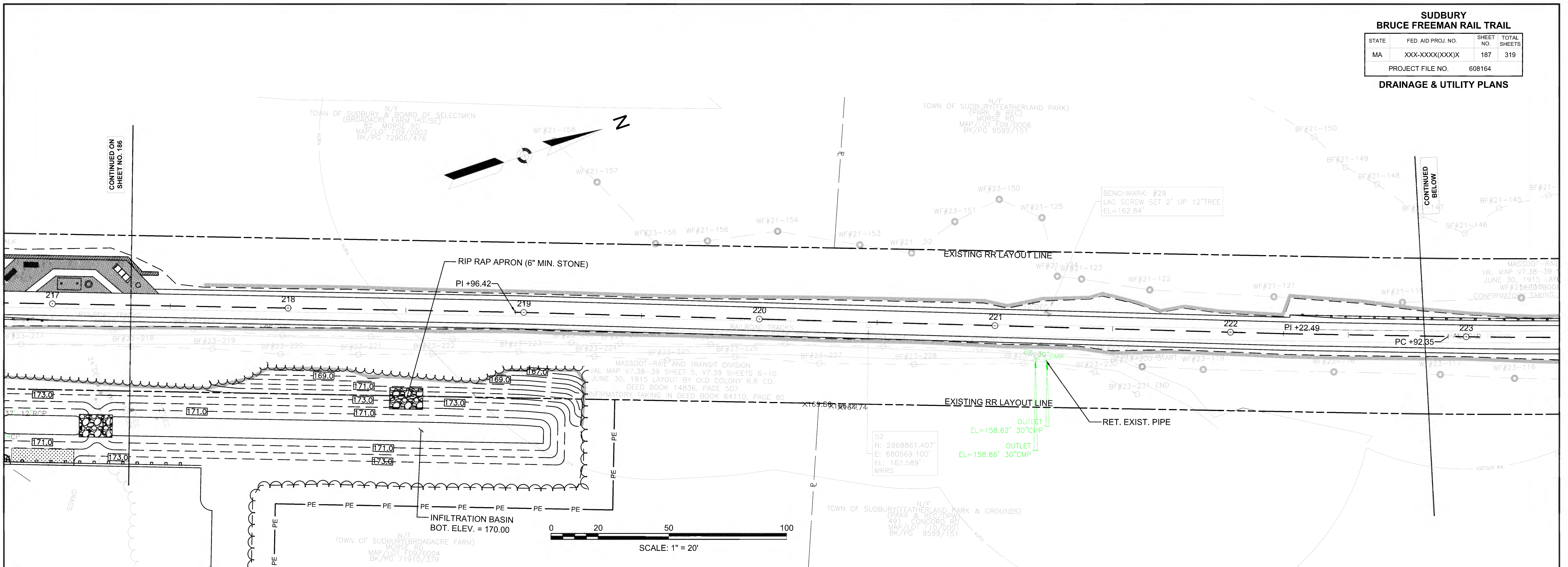

CONTINUED ON SHEET NO. 186

CONTINUED BELOW

CONTINUED ABOVE

CONTINUED ON SHEET NO. 188

**SUDBURY
BRUCE FREEMAN RAIL TRAIL**

STATE	FED. AID PROJ. NO.	SHEET NO.	TOTAL SHEETS
MA	XXX-XXXX(XXX)X	188	319

PROJECT FILE NO. 608164

DRAINAGE & UTILITY PLANS

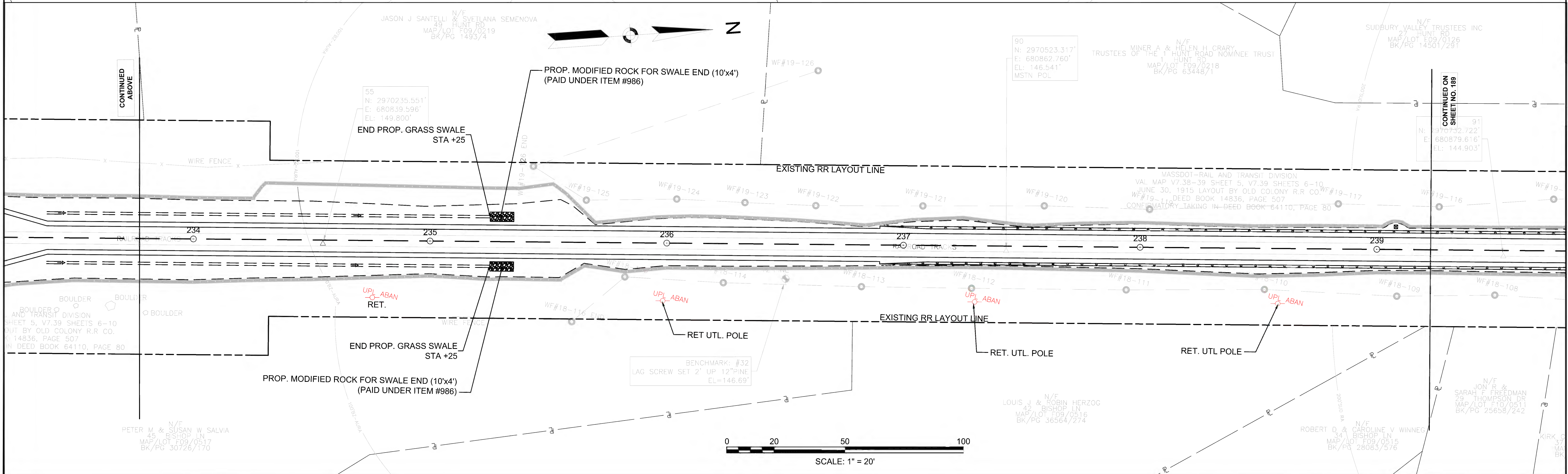
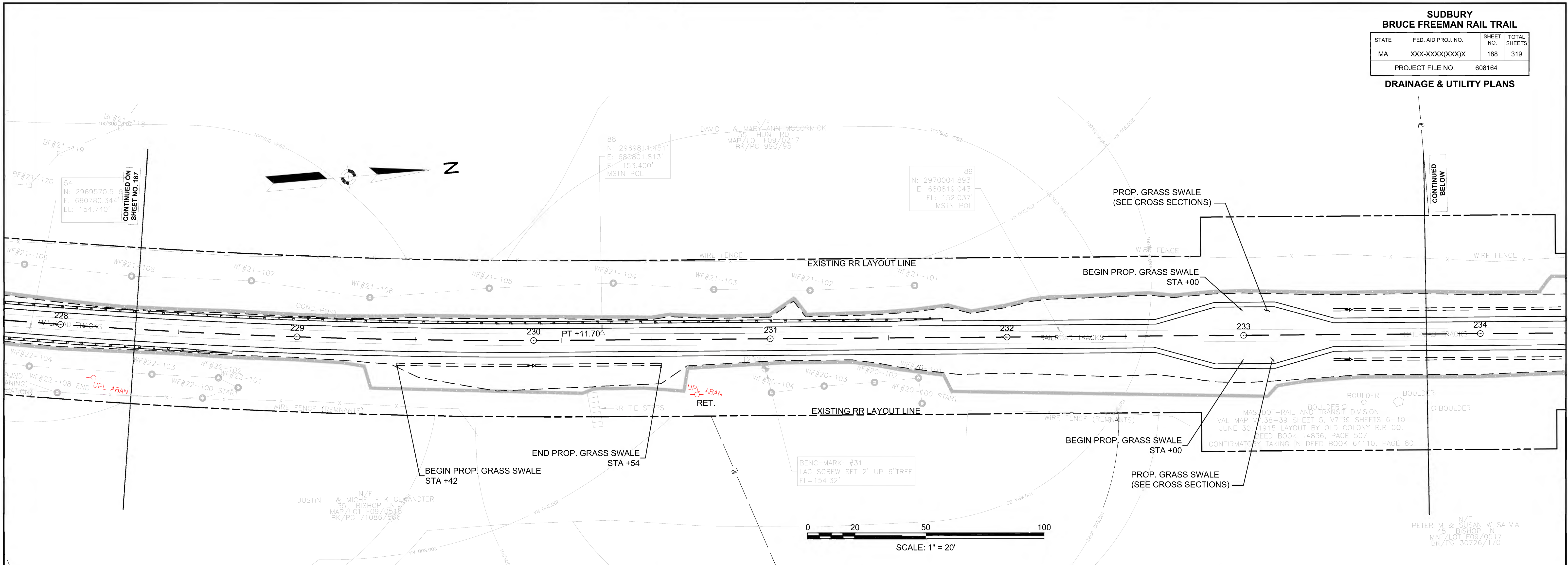

**SUDBURY
BRUCE FREEMAN RAIL TRAIL**

STATE	FED. AID PROJ. NO.	SHEET NO.	TOTAL SHEETS
MA	XXX-XXXX(XXX)X	189	319
PROJECT FILE NO.		608164	

DRAINAGE & UTILITY PLANS

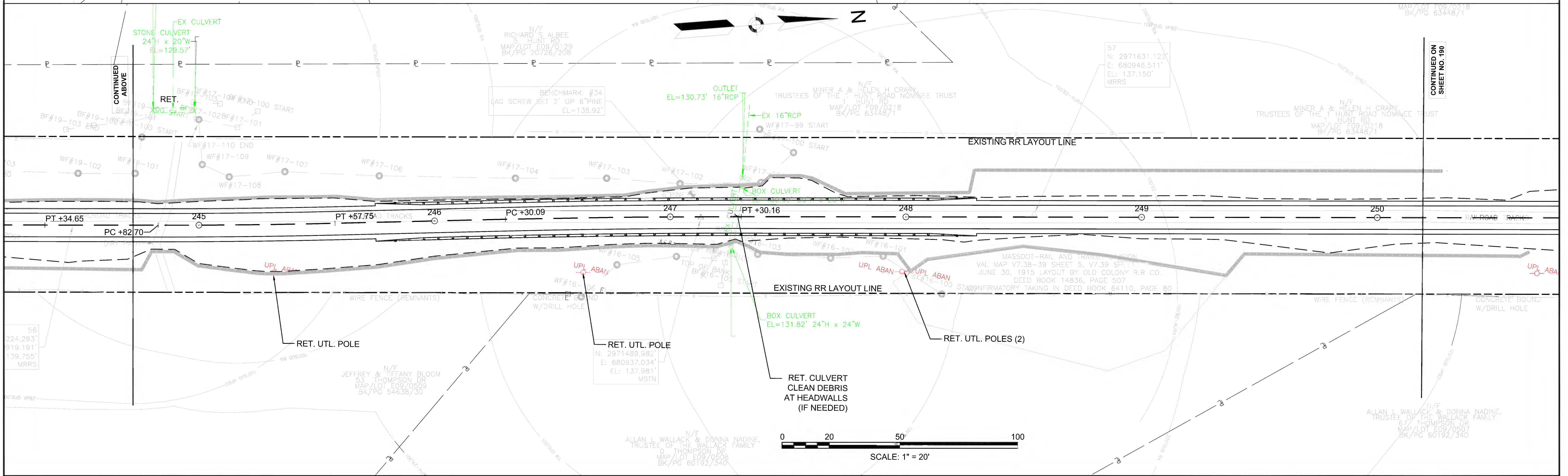
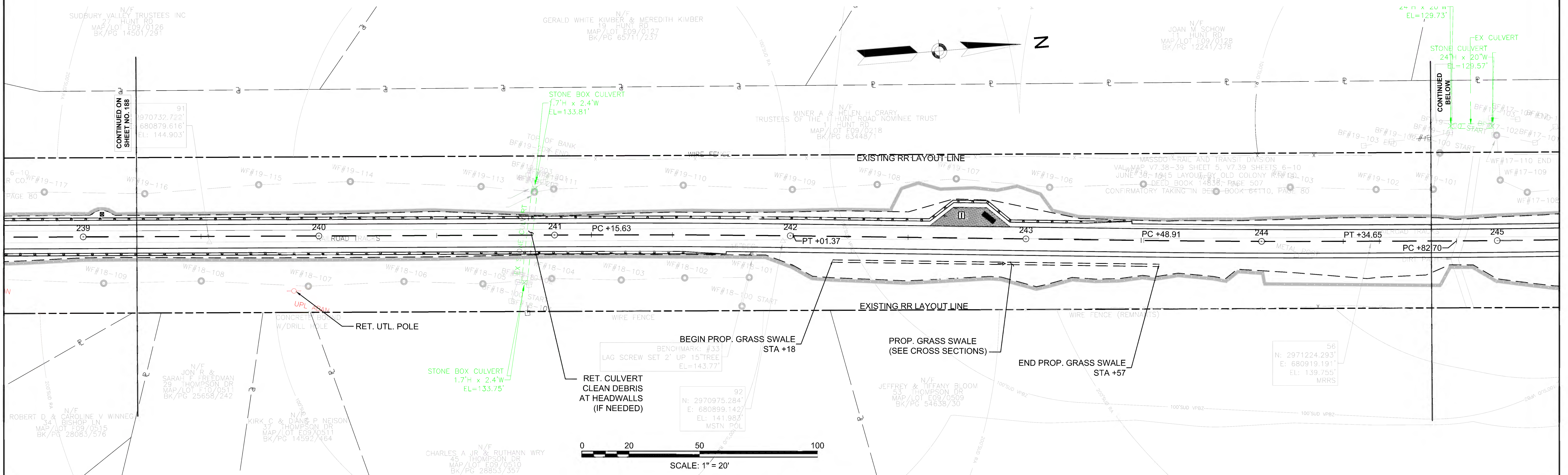

**SUDBURY
BRUCE FREEMAN RAIL TRAIL**

STATE	FED. AID PROJ. NO.	SHEET NO.	TOTAL SHEETS
MA	XXX-XXXX(XXX)X	190	319
PROJECT FILE NO.		608164	

DRAINAGE & UTILITY PLANS

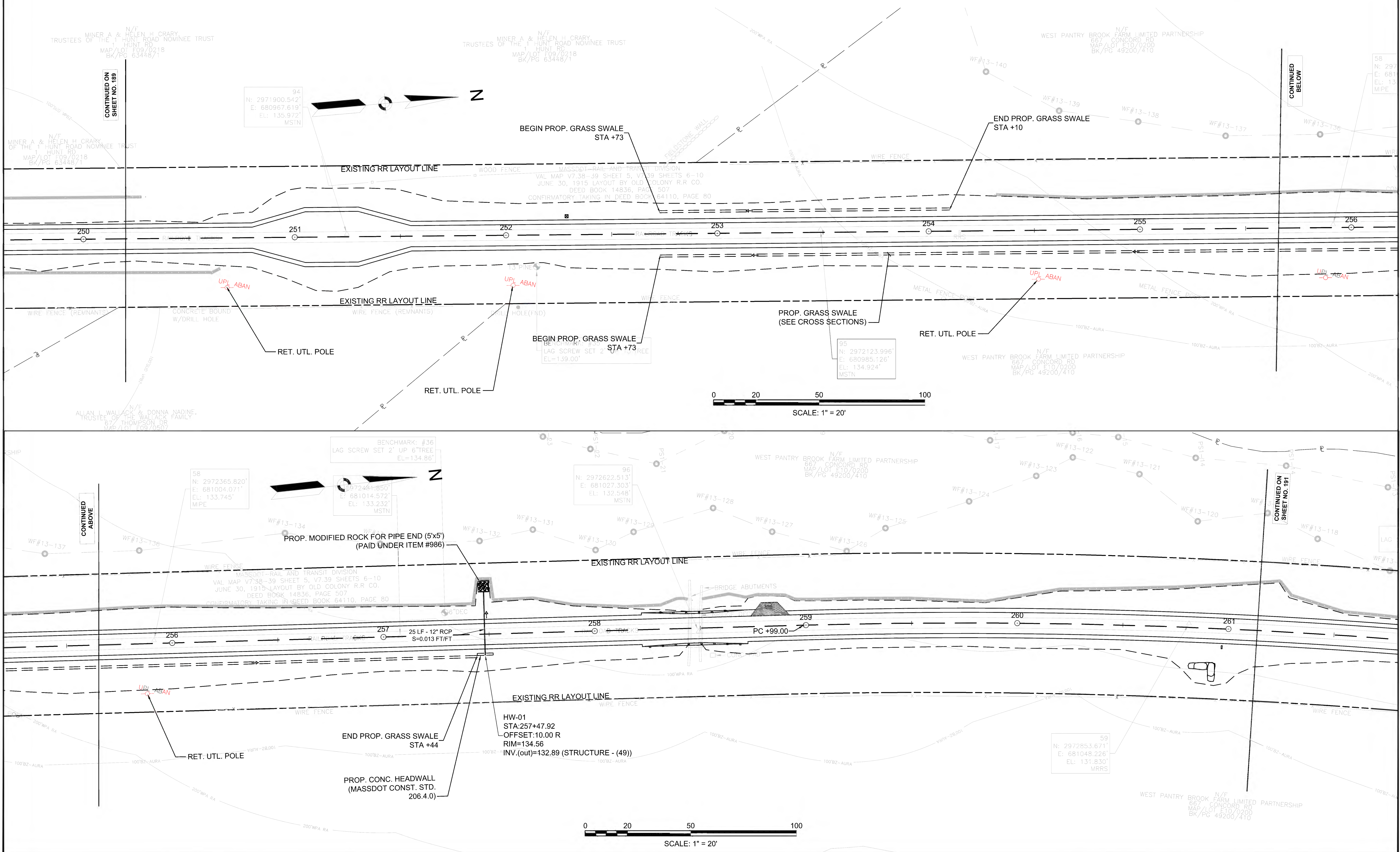

CONTINUED ON
SHEET NO. 189

CONTINUED
BELOW

CONTINUED
ABOVE

CONTINUED ON
SHEET NO. 191

**SUDBURY
BRUCE FREEMAN RAIL TRAIL**

STATE	FED. AID PROJ. NO.	SHEET NO.	TOTAL SHEETS
MA	XXX-XXXX(XXX)X	191	319
PROJECT FILE NO.		608164	

DRAINAGE & UTILITY PLANS

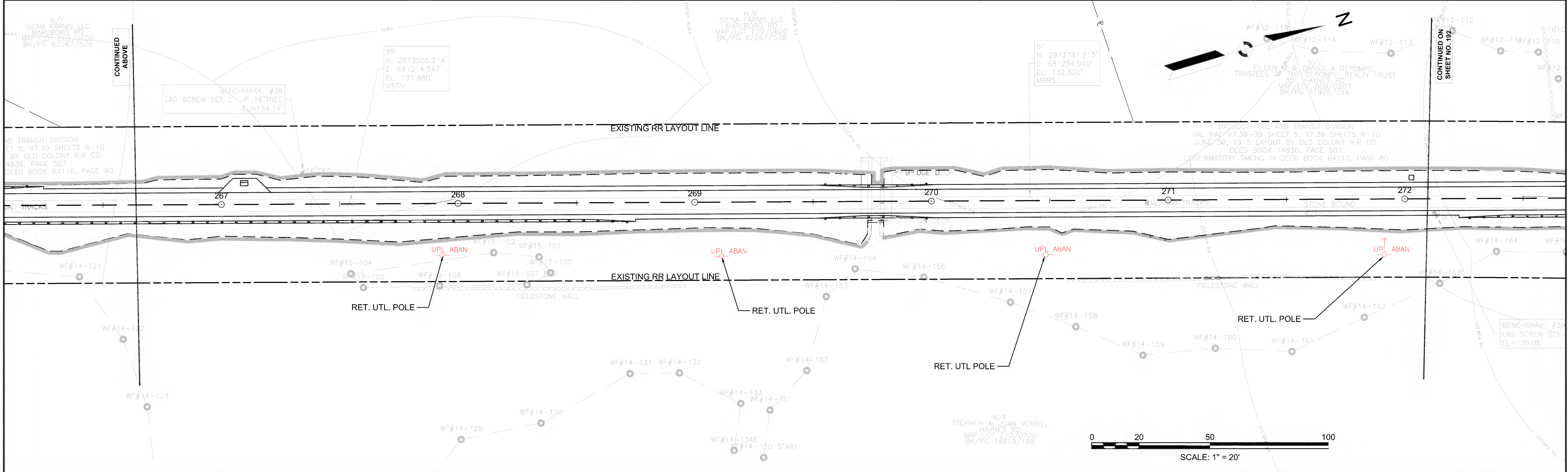
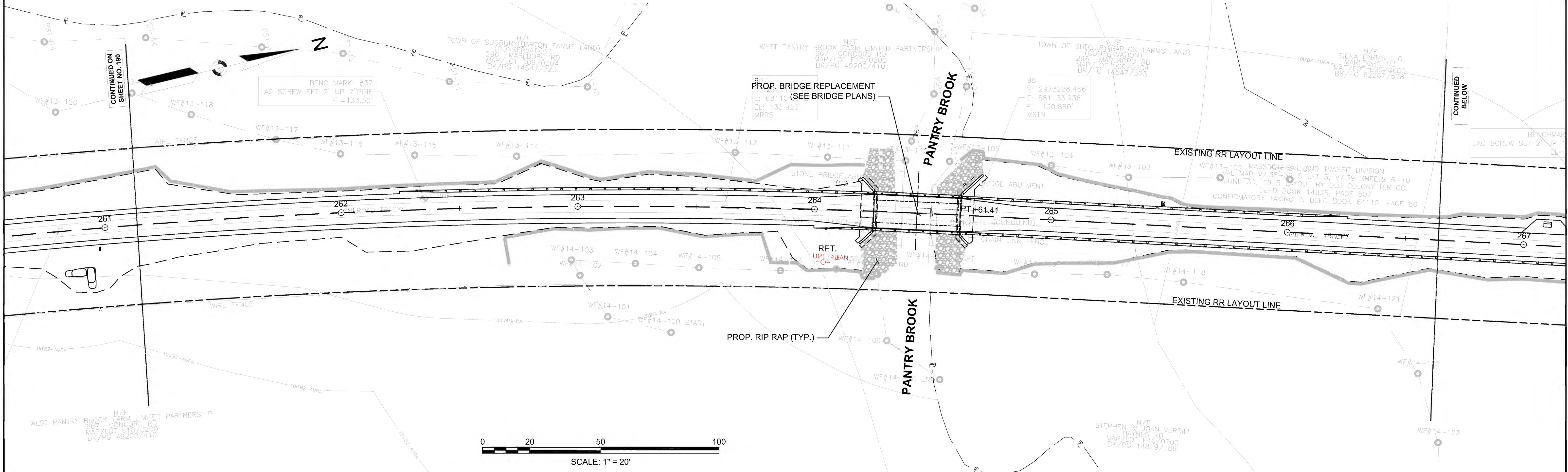

CONTINUED ON SHEET NO. 190

CONTINUED BELOW

CONTINUED ABOVE

CONTINUED ON SHEET NO. 192

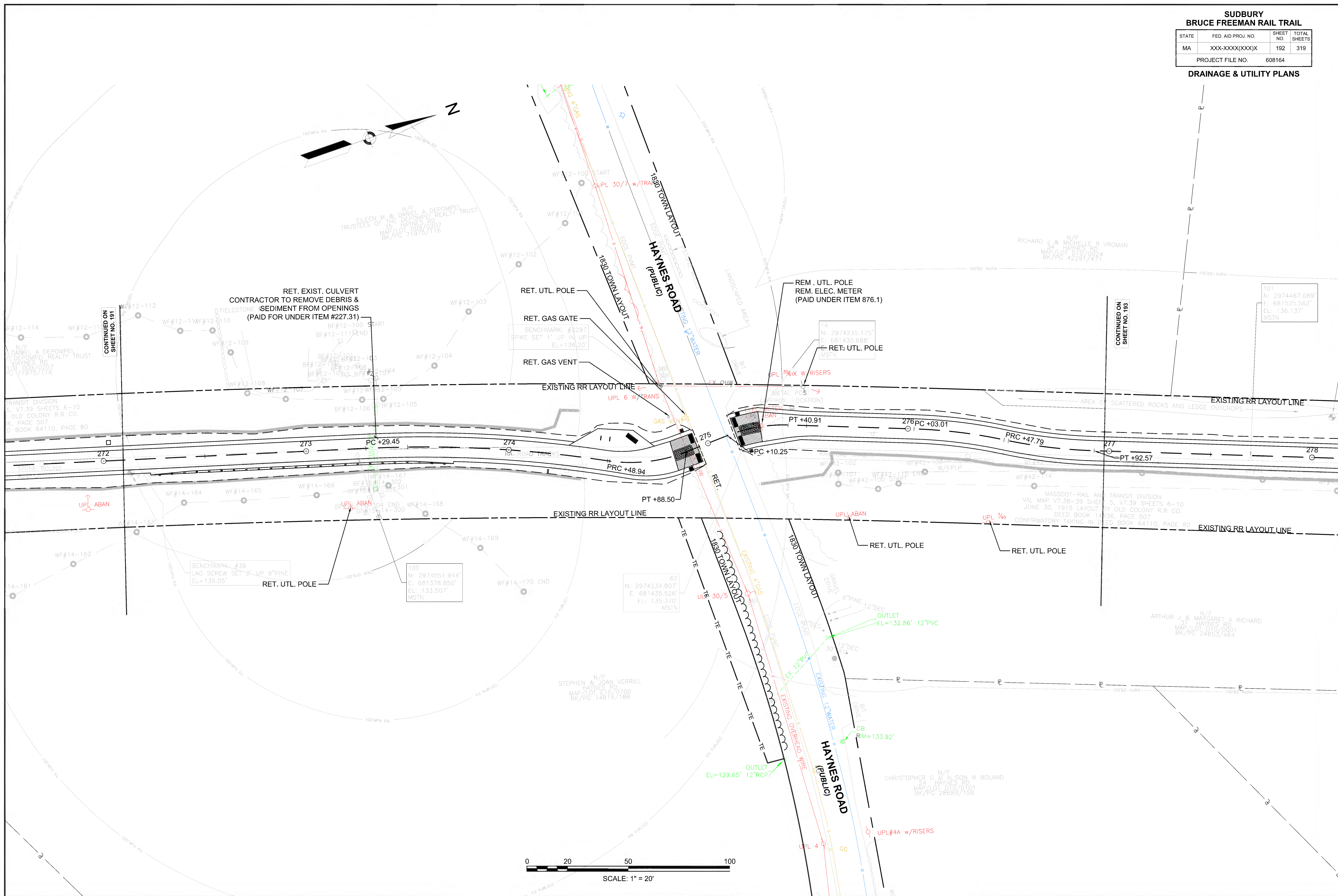

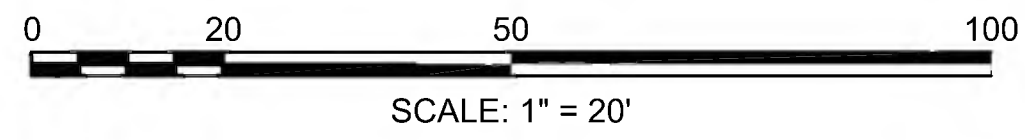
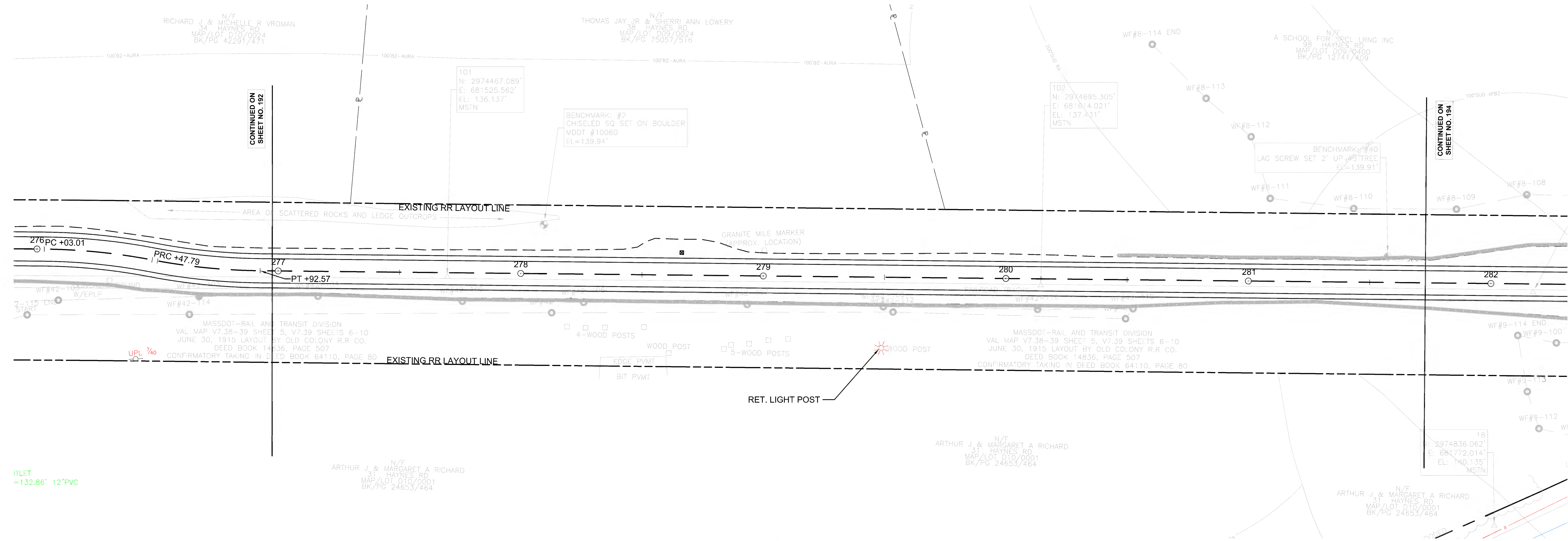
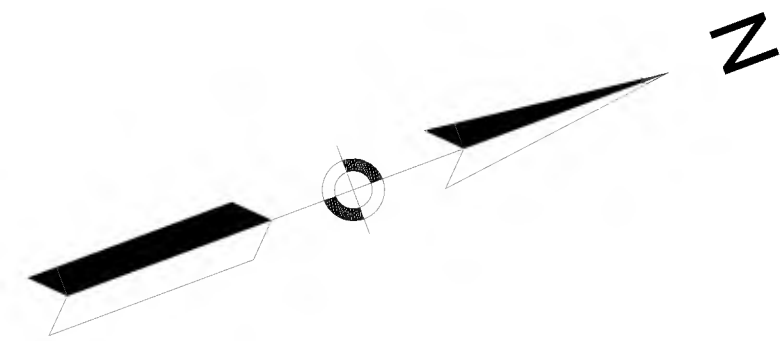

CONTINUED ON
SHEET NO. 192

CONTINUED ON
SHEET NO. 194

ITLET
= 132.86' 12" PVC

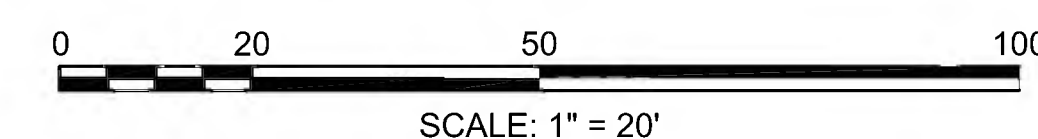
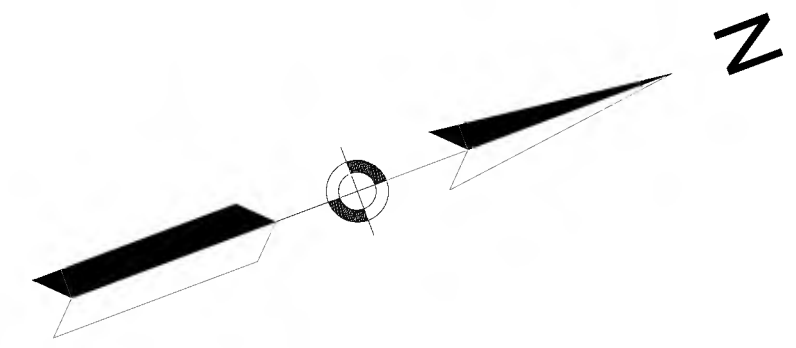
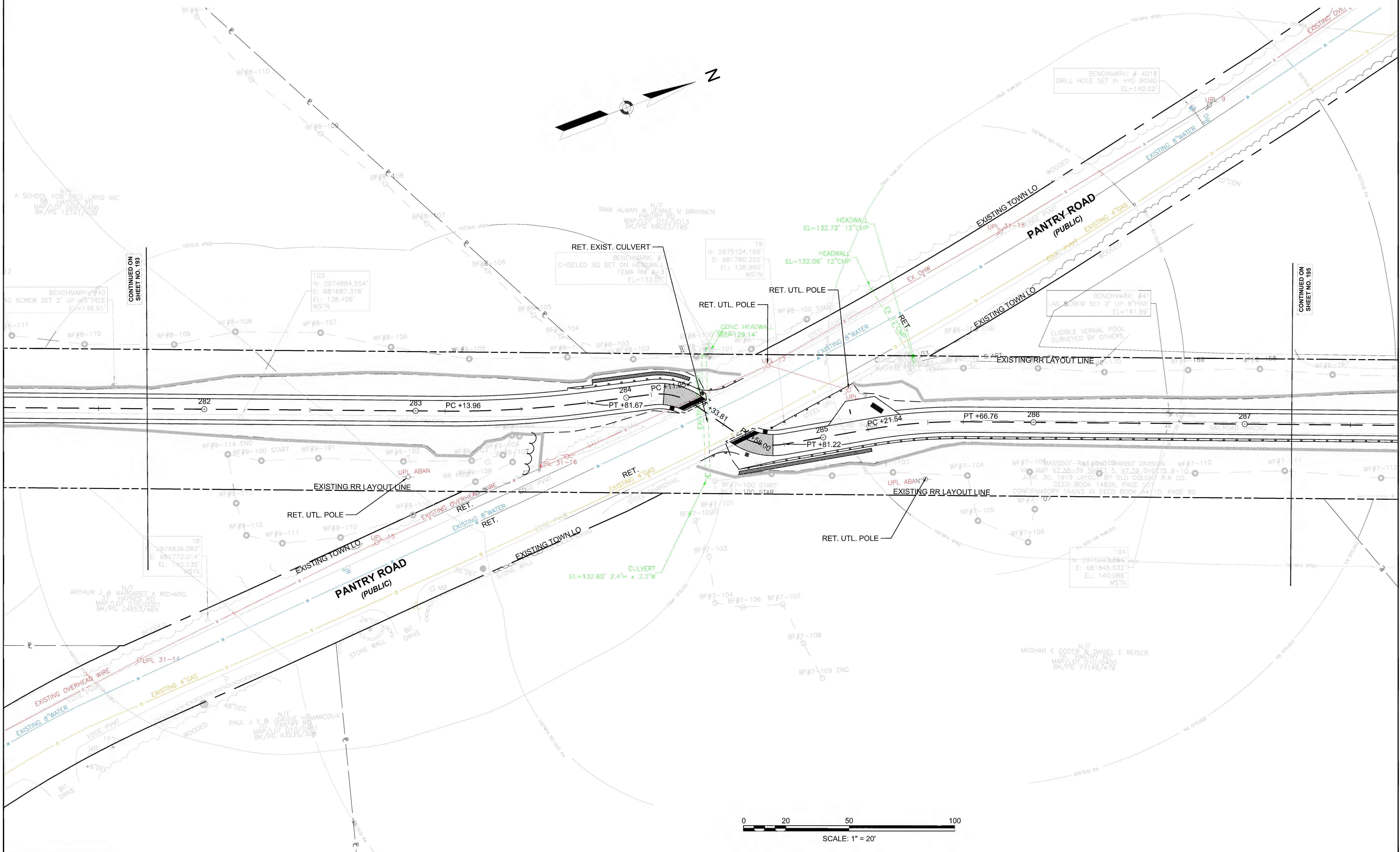

CONTINUED ON
SHEET NO. 193

CONTINUED ON
SHEET NO. 195

**SUDBURY
BRUCE FREEMAN RAIL TRAIL**

STATE	FED. AID PROJ. NO.	SHEET NO.	TOTAL SHEETS
MA	XXX-XXXX(XXX)X	196	319
PROJECT FILE NO.		608164	

DRAINAGE & UTILITY PLANS

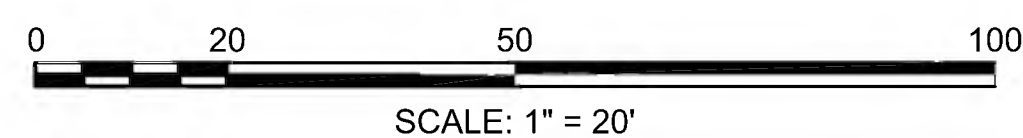
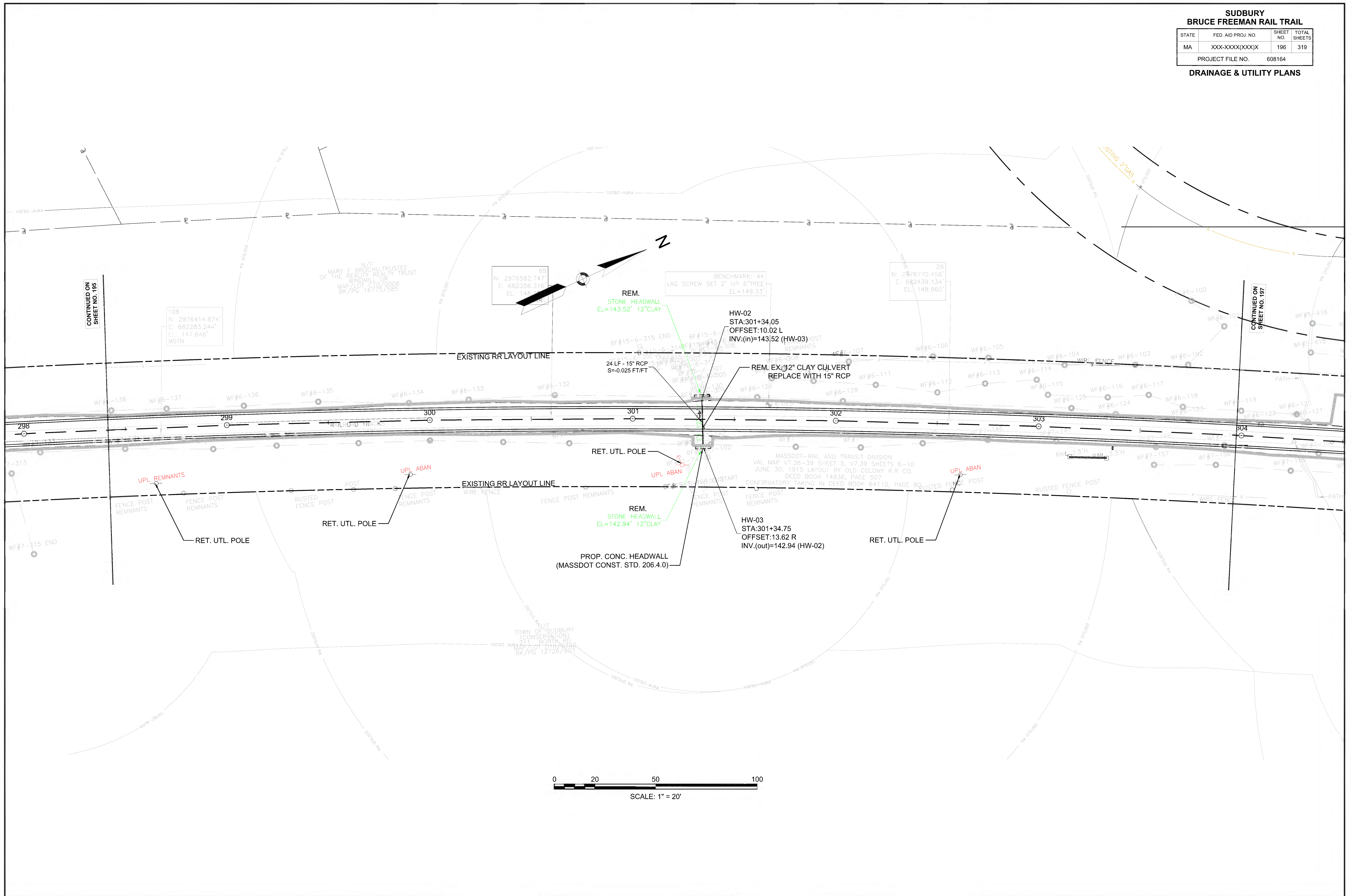

CONTINUED ON
SHEET NO. 195

CONTINUED ON
SHEET NO. 197

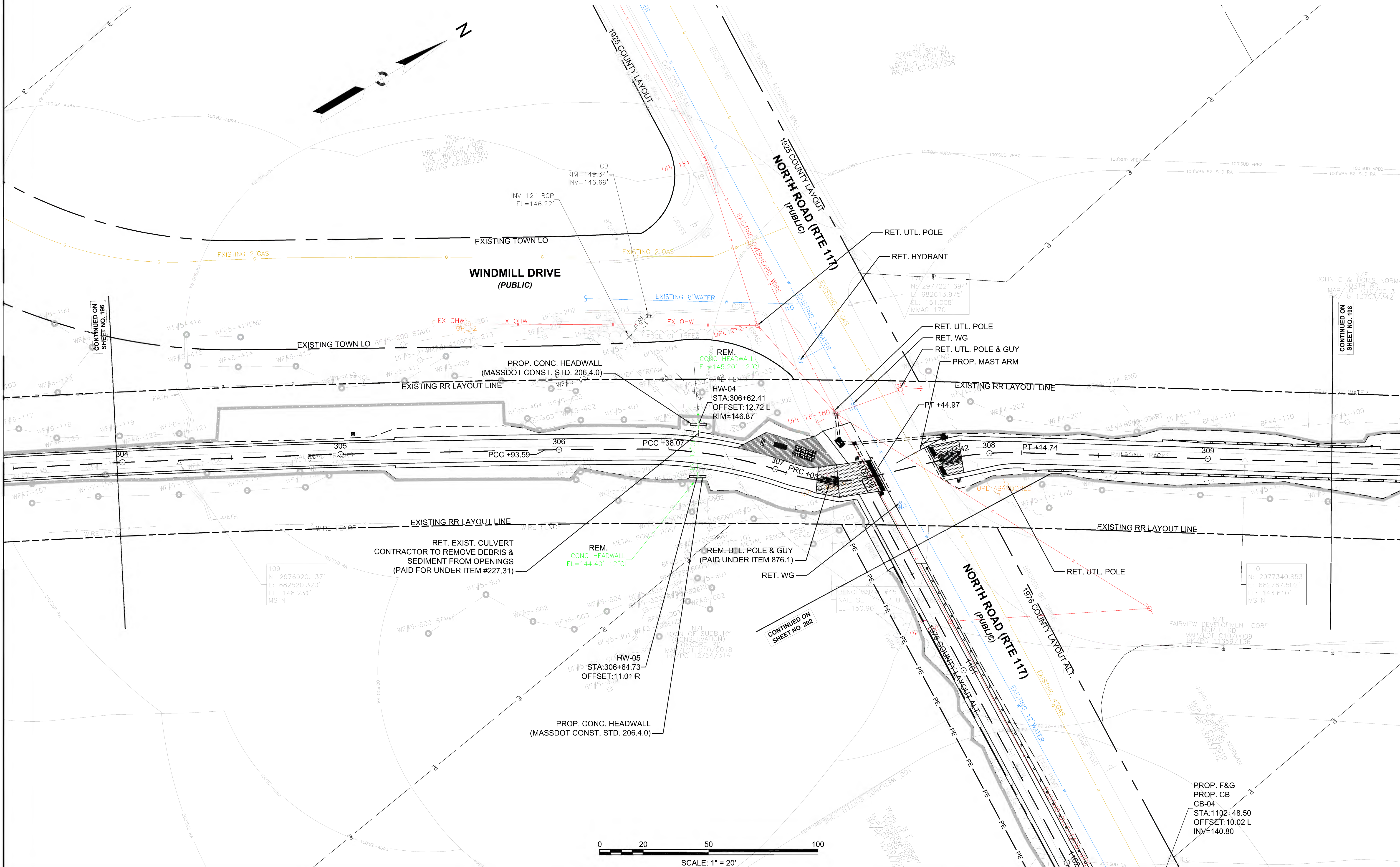

CONTINUED ON
SHEET NO. 196

CONTINUED ON
SHEET NO. 198

CONTINUED ON
SHEET NO. 202

PROP. F&G
PROP. CB
CB-04
STA:1102+48.50
OFFSET:10.02 L
INV=140.80

0 20 50 100
SCALE: 1" = 20'

**SUDBURY
BRUCE FREEMAN RAIL TRAIL**

STATE	FED. AID PROJ. NO.	SHEET NO.	TOTAL SHEETS
MA	XXX-XXXX(XXX)X	198	319
PROJECT FILE NO.		608164	

DRAINAGE & UTILITY PLANS

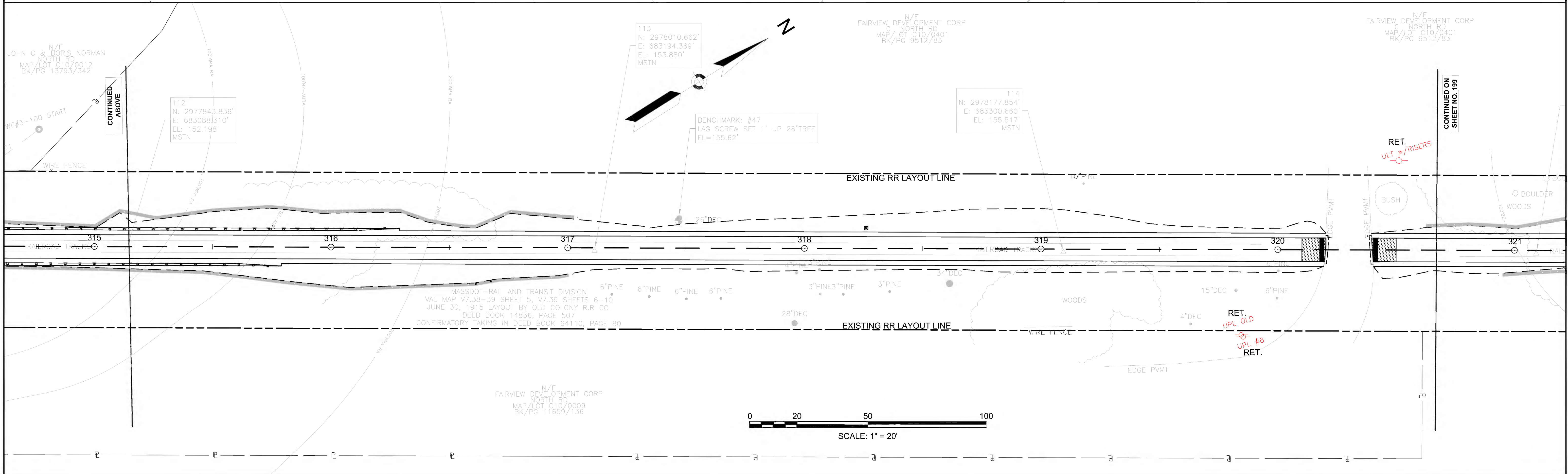
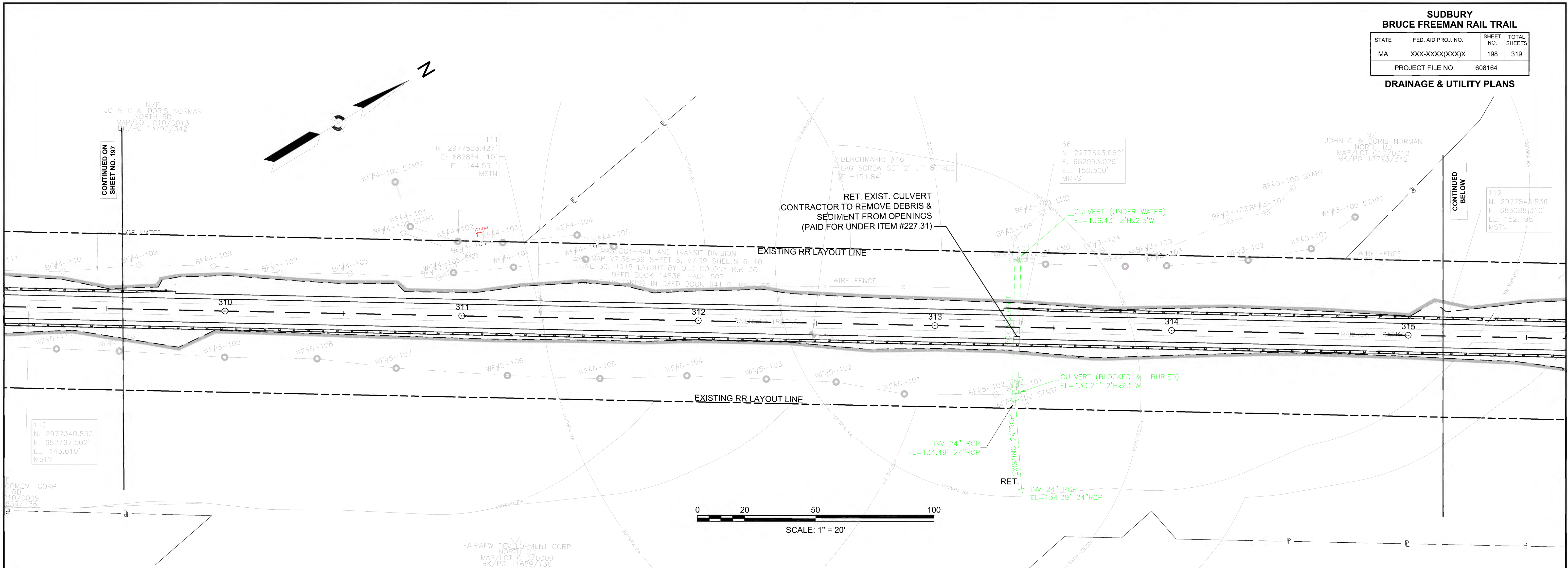

JOHN C & DORIS NORMAN
NORTH RD
MAP/LOT C10/0013
BK/PG 13793/342

111
N: 2977523.427'
E: 682884.110'
EL: 144.551'
MSTN

BENCHMARK: #46
LAG SCREW SET 2' UP 8" TREE
EL=151.84'

66
N: 2977693.962'
E: 682993.029'
EL: 150.500'
MRRS

JOHN C & DORIS NORMAN
NORTH RD
MAP/LOT C10/0012
BK/PG 13793/342

112
N: 2977845.836'
E: 683088.310'
EL: 152.198'
MSTN

110
N: 2977340.853'
E: 682767.502'
EL: 143.610'
MSTN

FAIRVIEW DEVELOPMENT CORP
NORTH RD
MAP/LOT C10/0009
BK/PG 11659/136

FAIRVIEW DEVELOPMENT CORP
NORTH RD
MAP/LOT C10/0009
BK/PG 11659/136

JOHN C & DORIS NORMAN
NORTH RD
MAP/LOT C10/0012
BK/PG 13793/342

112
N: 2977845.836'
E: 683088.310'
EL: 152.198'
MSTN

113
N: 2978010.662'
E: 683194.369'
EL: 153.880'
MSTN

BENCHMARK: #47
LAG SCREW SET 1' UP 26" TREE
EL=155.62'

114
N: 2978177.854'
E: 683300.660'
EL: 155.517'
MSTN

FAIRVIEW DEVELOPMENT CORP
NORTH RD
MAP/LOT C10/0401
BK/PG 9512/83

FAIRVIEW DEVELOPMENT CORP
NORTH RD
MAP/LOT C10/0401
BK/PG 9512/83

CONTINUED ON
SHEET NO. 189

**SUDBURY
BRUCE FREEMAN RAIL TRAIL**

STATE	FED. AID PROJ. NO.	SHEET NO.	TOTAL SHEETS
MA	XXX-XXXX(XXX)X	199	319
PROJECT FILE NO.		608164	

DRAINAGE & UTILITY PLANS

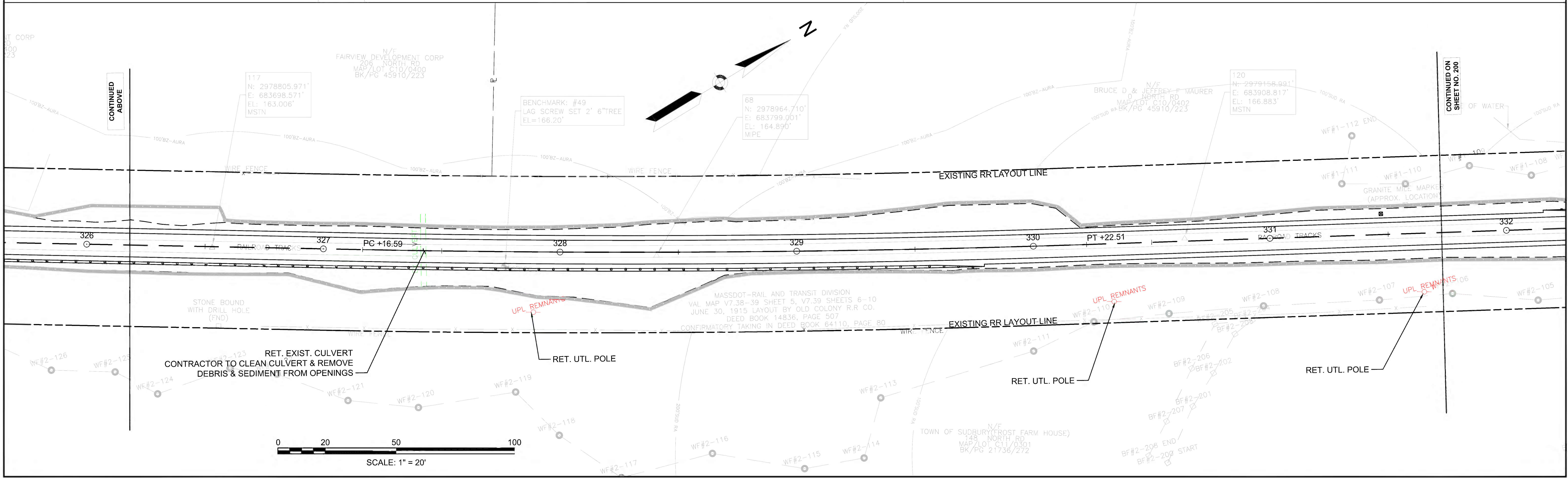
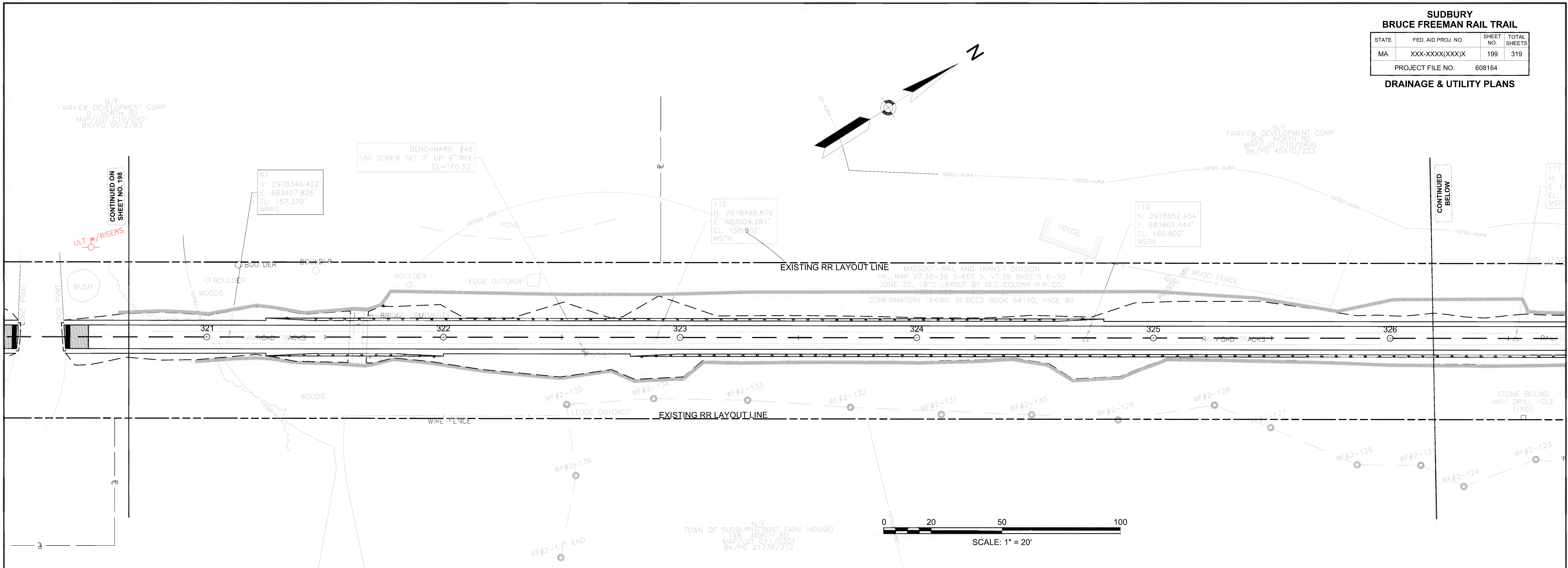

SUDBURY
BRUCE FREEMAN RAIL TRAIL

STATE	FED. AID PROJ. NO.	SHEET NO.	TOTAL SHEETS
MA	XXX-XXXX(XXX)X	200	319
PROJECT FILE NO.		608164	

DRAINAGE & UTILITY PLANS

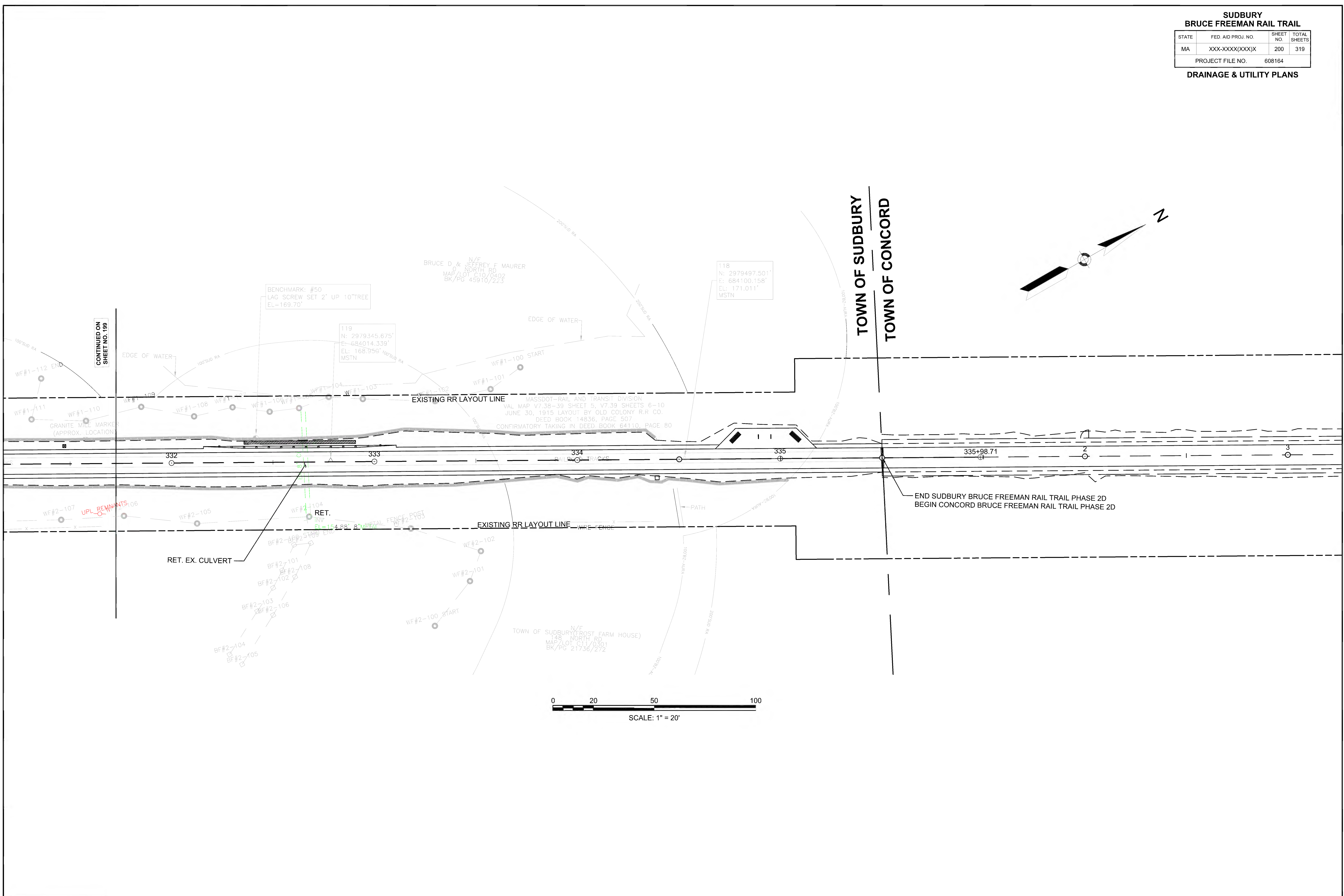

**SUDBURY
BRUCE FREEMAN RAIL TRAIL**

STATE	FED. AID PROJ. NO.	SHEET NO.	TOTAL SHEETS
MA	XXX-XXXX(XXX)X	206	319
PROJECT FILE NO.		608164	

WETLAND REPLICATION PLANS

WETLAND REPLICATION PLAN NOTES

GENERAL NOTES

1. THE CONTRACTOR SHALL MAKE ALL NECESSARY CONSTRUCTION NOTIFICATIONS AND APPLY FOR AND OBTAIN ALL NECESSARY PERMITS PRIOR TO CONSTRUCTION. THE CONTRACTOR SHALL ALSO PAY ALL FEES AND POST ALL BONDS ASSOCIATED WITH THE SAME, AND COORDINATE WITH THE ENGINEER AND ARCHITECT AS REQUIRED.
2. CONTRACTOR SHALL BE SOLELY RESPONSIBLE FOR JOB SITE SAFETY AND ALL CONSTRUCTION MEANS AND METHODS.
3. LIMIT OF WORK SHALL BE EROSION CONTROL BARRIERS, LIMIT OF GRADING AND SITE PROPERTY LINES AND/OR AS INDICATED ON DRAWINGS.
4. ANY ALTERATION TO THESE DRAWINGS MADE IN THE FIELD DURING CONSTRUCTION SHALL BE RECORDED BY THE CONTRACTOR ON RECORD DOCUMENTS.
5. ANY AREA OUTSIDE THE LIMIT OF WORK THAT IS DISTURBED SHALL BE RESTORED TO ITS ORIGINAL CONDITION AT NO COST TO OWNER.
6. EXISTING TREES AND SHRUBS OUTSIDE THE LIMITS OF GRADING SHALL BE REMOVED ONLY UPON PRIOR APPROVAL OF THE OWNER.
7. FOR DRAWING LEGIBILITY, ALL EXISTING TOPOGRAPHIC FEATURES, EXISTING UTILITIES, PROPERTY BOUNDARIES, EASEMENTS, ETC. MAY NOT BE SHOWN ON ALL DRAWINGS. REFER TO ALL REFERENCED DRAWINGS AND OTHER DRAWINGS IN THIS SET FOR ADDITIONAL INFORMATION.
8. THE CONTRACTOR SHALL BE RESPONSIBLE FOR COMPLIANCE WITH ALL PERMIT CONDITIONS. THE CONTRACTOR SHALL BE RESPONSIBLE FOR SUBMITTING, SECURING AND COMPLIANCE WITH THE NATIONAL POLLUTANT DISCHARGE ELIMINATION SYSTEM (NPDES) CONSTRUCTION GENERAL PERMIT, AS ADMINISTERED BY THE UNITED STATES ENVIRONMENTAL PROTECTION AGENCY.

EROSION CONTROL AND SEDIMENTATION NOTES

1. CONTRACTOR SHALL MAINTAIN ANY EROSION CONTROL MEASURES DURING THE ENTIRE CONSTRUCTION PERIOD.
2. ANY SEDIMENT TRACKED ONTO THE PUBLIC RIGHT-OF-WAYS SHALL BE SWEEPED AT THE END OF EACH WORKING DAY.
3. ALL DEBRIS GENERATED DURING SITE PREPARATION ACTIVITIES SHALL BE LEGALLY DISPOSED OF OFF SITE.
4. SITE ELEMENTS TO REMAIN MUST BE PROTECTED FOR DURATION OF PROJECT.
5. ADDITIONAL EROSION CONTROL MEASURES SHALL BE IMPLEMENTED AS CONDITIONS WARRANT OR AS DIRECTED BY THE OWNER OR OWNER'S REPRESENTATIVE (E.G., PROFESSIONAL ENGINEER, WETLAND SCIENTIST, CERTIFIED ECOLOGICAL RESTORATION PRACTITIONER).
6. THE WETLAND REPLICATION SITE WILL BE ACCESSED FROM THE BRUCE FREEMAN RAIL TRAIL. ALL POINTS OF CONSTRUCTION EGRESS OR INGRESS SHALL BE MAINTAINED TO PREVENT TRACKING OR FLOWING OF SEDIMENT ONTO PUBLIC ROADS.
7. EXTREME CARE SHALL BE EXERCISED SO AS TO PREVENT ANY UNSUITABLE MATERIAL FROM ENTERING WETLAND LOCATED OUTSIDE THE LIMIT OF WORK AND OFF PROPERTY.
8. ADDITIONAL EROSION CONTROLS SHALL BE LOCATED AS CONDITIONS WARRANT OR AS DIRECTED BY THE OWNER OR THEIR REPRESENTATIVE.

LAYOUT AND MATERIALS NOTES

1. ALL LINES AND DIMENSIONS ARE PARALLEL OR PERPENDICULAR TO THE LINES FROM WHICH THEY ARE MEASURED UNLESS OTHERWISE INDICATED.
2. CONTRACTOR SHALL REPORT SIGNIFICANT CONFLICTS TO THE OWNER AND THE ENGINEER FOR RESOLUTION.
3. THE CONTRACTOR SHALL NOTIFY THE ENGINEER OF ANY DISCREPANCIES BETWEEN SITE PLAN DIMENSIONS AND BUILDING PLANS BEFORE PROCEEDING WITH ANY PORTION OF SITE WORK WHICH MAY BE AFFECTED SO THAT PROPER ADJUSTMENTS TO THE SITE LAYOUT CAN BE MADE IF NECESSARY.
4. PROTECT EXISTING PROPERTY MONUMENTS AND ABUTTING PROPERTIES DURING CONSTRUCTION ACTIVITIES.

GRADING, DRAINAGE AND UTILITY NOTES

1. UNDERGROUND UTILITIES WERE COMPILED FROM AVAILABLE RECORD PLANS OF UTILITY COMPANIES AND PUBLIC AGENCIES, ARE APPROXIMATE AND ASSUMED. BEFORE COMMENCING SITE WORK IN ANY AREA, CONTACT "DIG SAFE" AT 1-888-344-7233 AND THE OWNER TO ACCURATELY LOCATE UNDERGROUND UTILITIES. ANY DAMAGE TO EXISTING UTILITIES OR STRUCTURES SHALL BE THE CONTRACTOR'S RESPONSIBILITY. NO EXCAVATION SHALL BE DONE UNTIL UTILITY COMPANIES AND THE OWNER ARE PROPERLY NOTIFIED IN ADVANCE.
2. THE CONTRACTOR SHALL BE RESPONSIBLE FOR VERIFYING THAT THE PROPOSED IMPROVEMENTS SHOWN ON THE PLANS DO NOT CONFLICT WITH ANY KNOWN EXISTING OR OTHER PROPOSED IMPROVEMENTS. IF ANY CONFLICTS ARE DISCOVERED, THE CONTRACTOR SHALL NOTIFY THE OWNER AND THE ENGINEER PRIOR TO INSTALLATION OF ANY PORTION OF THE SITE WORK WHICH WOULD BE AFFECTED.
3. ALL WORK PERFORMED AND ALL MATERIALS FURNISHED SHALL CONFORM WITH THE LINES, GRADES AND OTHER SPECIFIC REQUIREMENTS OR SPECIFICATIONS FOR THE PROJECT AS SHOWN ON THE PLANS.
4. THE CONTRACTOR SHALL VERIFY EXISTING GRADES IN THE FIELD AND REPORT ANY DISCREPANCIES IMMEDIATELY TO THE ENGINEER OR CERTIFIED ECOLOGICAL RESTORATION PRACTITIONER. THE CONTRACTOR SHALL MAKE ALL ARRANGEMENTS FOR THE ALTERATION AND ADJUSTMENT OF ANY OTHER PRIVATE UTILITIES BY THE UTILITY COMPANIES, AS REQUIRED. WHERE AN EXISTING UTILITY IS FOUND TO CONFLICT WITH THE PROPOSED WORK, THE LOCATION, ELEVATION AND SIZE OF THE UTILITY SHALL BE ACCURATELY DETERMINED WITHOUT DELAY BY THE CONTRACTOR, AND THE INFORMATION FURNISHED TO THE OWNER AND ENGINEER FOR RESOLUTION.
5. THE CONTRACTOR SHALL REMOVE ALL EROSION CONTROL BARRIERS AFTER REVEGETATION OF DISTURBED AREAS AND AFTER APPROVAL OF THE CONSERVATION COMMISSION AND WETLAND SPECIALIST OR CERTIFIED ECOLOGICAL RESTORATION PRACTITIONER.
6. PITCH EVENLY BETWEEN SPOT GRADES.

WETLAND CONSTRUCTION NOTES

1. A PRECONSTRUCTION MEETING SHALL BE HELD BEFORE INITIATING CONSTRUCTION. THE PRECONSTRUCTION MEETING SHALL BE ATTENDED BY THE DESIGNATED PROFESSIONAL WETLAND SCIENTIST, SITE ENGINEER, CONSTRUCTION GENERAL MANAGER, SITE CONTRACTOR, LANDSCAPE CONTRACTOR, AND ANY OTHER CONTRACTOR INVOLVED IN THE REPLICATION ACTIVITY.
2. WETLAND REPLICATION SHALL BE CONDUCTED IN ACCORDANCE WITH THESE DRAWINGS, SPECIAL PROVISIONS AND REQUIREMENTS OUTLINED IN THE ORDER OF CONDITIONS AS ISSUED BY THE TOWN OF SUDBURY CONSERVATION COMMISSION.
3. ALL EXISTING WETLAND DELINEATION WITHIN 100 FEET OF THE WORK AREA WILL BE RE-FLAGGED EVERY 25 FEET.
4. EROSION CONTROLS SHALL BE INSTALLED PER EROSION CONTROL PLAN, REPAIRED AND MAINTAINED THROUGHOUT THE CONSTRUCTION PERIOD OF WETLAND MITIGATION AND UNTIL THE SITE IS FULLY STABILIZED BY VEGETATION (SEED MIX). EROSION CONTROLS SHALL THEN BE REMOVED FROM THE SITE.
5. A WETLAND SCIENTIST SHALL BE ON SITE TO MONITOR PLANTING AND GRADING OF THE WETLAND REPLICATION AREA TO ENSURE COMPLIANCE WITH APPROVED PLANS.
6. INVASIVE NON-NATIVE PLANT SPECIES IN OR IMMEDIATELY ADJACENT TO REPLICATION AREA SHALL BE IDENTIFIED AND TAGGED FOR ERADICATION OR REMOVAL. REMOVED INVASIVE PLANT MATERIAL SHALL BE DISPOSED OF AT AN APPROVED OFF-SITE LOCATION.
7. IF USED, HERBICIDE SELECTION AND TIMING FOR INVASIVE SPECIES CONTROL SHALL BE APPROVED BY A PROFESSIONAL WETLAND SCIENTIST OR OTHER QUALIFIED PROFESSIONAL.
8. IF USED, HERBICIDE APPLICATION FOR INVASIVE SPECIES CONTROL SHALL BE PERFORMED BY A PROFESSIONAL CERTIFIED BY THE STATE OF MASSACHUSETTS. DOCUMENTATION OF CERTIFICATION SHALL BE SUBMITTED TO THE SITE CONSTRUCTION GENERAL MANAGER.
9. GRADING AND PLANTINGS WILL NOT BE CONDUCTED DURING PERIODS OF HIGH WATER. CONSTRUCTION OF THE REPLICATION AREA WILL CONTINUE UNINTERRUPTED TO AVOID EROSION AND THE SILTATION OF WETLANDS.
10. COMPACTION OF SOILS IN THE WETLAND REPLICATION AREA SHALL BE MINIMIZED TO THE MAXIMUM EXTENT PRACTICABLE BY THE USE OF LOW-GROUND PRESSURE MACHINERY.
11. SHOULD COMPACTION OCCUR, SOILS SHALL BE TILLED OR DISKED IN TWO DIRECTIONS TO RE-FRACTURE A MINIMUM OF TWELVE (12) INCHES BELOW FINISHED GRADE.
12. BURIED ORGANIC WETLAND SOILS ENCOUNTERED DURING EXCAVATION MAY BE LEFT IN PLACE. IF TEMPORARY STOCKPILING OF WETLAND SOIL IS NECESSARY, MATERIAL MUST BE COVERED TO PREVENT LEACHING, MOISTURE LOSS AND SEDIMENT TRANSPORT.
13. GRADING LINES DEPICTED ON THE PLAN ARE DRAWN SMOOTHLY. ACTUAL SURFACE GRADES ACROSS WETLAND 'FLOOR' SHALL REFLECT HUMMOCK AND HOLLOW TOPOGRAPHY OF NATURAL WETLANDS.
14. THE SUBGRADE OF WETLAND REPLACEMENT AREAS WILL BE GRADED A MINIMUM OF ONE FOOT BELOW THE ADJACENT WETLANDS. NO GRADING WILL BE PERMITTED WITHIN THE EXISTING WETLAND AREAS EXCEPT TO CUT OPENINGS IN BERMS TO ESTABLISH HYDRAULIC CONDUCTIVITY BETWEEN THE REPLACEMENT WETLAND AND THE WETLAND REPLICATION.
15. FINAL SUB-GRADES SHALL BE REVIEWED AND APPROVED BY A PROFESSIONAL WETLAND SCIENTIST AFTER REVIEW OF SEASONAL, LOCAL HIGH GROUNDWATER MONITORING DATA AND FIELD CONDITIONS. MODIFICATIONS OF FINAL GRADES MAY BE MADE IN THE FIELD AS DIRECTED BY A PROFESSIONAL WETLAND SCIENTIST OR CERTIFIED ECOLOGICAL RESTORATION PRACTITIONER.
16. A TWELVE-INCH LAYER OF NATURAL ORGANIC SOIL OR MIXTURE OF GOOD QUALITY TOPSOIL AND CLEAN LEAF COMPOST PER THE SOIL SPECIFICATIONS OF ITEM 755.35 WILL BE PLACED IN THE BOTTOM OF THE REPLACEMENT AREA. SOIL AND COMPOST SHOULD BE CERTIFIED FREE OF INVASIVE PLANT SEEDS OR OTHER ARTIFICIAL MATERIAL.
17. SIDE SLOPES OF NON-WETLAND (UPLAND) AREAS SHALL BE GRADED WITH A MINIMUM OF FOUR INCHES OF THE SOIL MIXTURE AS DESCRIBED ABOVE.
18. NO SOIL AMENDMENT OR FERTILIZER SHALL BE APPLIED OR ADDED UNLESS DIRECTED BY A PROFESSIONAL WETLAND SCIENTIST.
19. WHERE CALLED FOR, REPLICATION AREAS SHALL BE SEEDED IMMEDIATELY FOLLOWING PLACEMENT AND FINAL GRADING INCLUDING MICROTOPOGRAPHY. SPRING SEEDING SHOULD OCCUR AFTER THE GROUND THAWS AND BEFORE JUNE 30. FALL SEEDING SHOULD OCCUR AFTER OCTOBER 15 AND BEFORE THE SOIL FREEZES.
20. ALL WETLAND AREAS SHALL BE SEEDED USING THE SEED MIX SPECIFIED IN ITEM 765.554 WETLAND MIX/BASIN MIX AND SHALL BE APPLIED AT A RATE ACCORDING TO THE ITEM SPECIFICATION.
21. UPLAND AREAS SHALL BE SEEDED USING THE SEED MIX SPECIFIED IN ITEM 765.416. UPLAND SHADE MIX AND SHALL BE APPLIED AT A RATE ACCORDING TO THE ITEM SPECIFICATION.
22. SEED SHALL BE FRESH, RECLEANED SEED OF THE LATEST CROP. SEED SHALL BE DELIVERED TO THE SITE IN THE ORIGINAL CONTAINERS WHICH SHALL BEAR THE VENDOR'S GUARANTEE OF ANALYSIS.
23. DEVIATIONS FROM THE PLANTING SCHEDULE AND/OR APPROVED PLANTING LIST MUST BE APPROVED IN ADVANCE BY A PROFESSIONAL WETLAND SCIENTIST OR CERTIFIED ECOLOGICAL RESTORATION PRACTITIONER.
24. THE LANDSCAPE CONTRACTOR SHALL CLEAN UP AND REMOVE ANY DEBRIS FROM THE SITE CAUSED BY THE LANDSCAPE CONTRACTOR.
25. PLANT LISTS MAY BE ALTERED BASED ON FIELD CONDITIONS AS DIRECTED BY A PROFESSIONAL WETLAND SCIENTIST.
26. ALL PLANT MATERIALS SHALL CARRY A FULL GUARANTEE FOR A PERIOD OF ONE YEAR FROM THE DATE OF FINAL ACCEPTANCE TO INCLUDE PROMPT TREATMENT OR REMOVAL AND REPLACEMENT OF ANY PLANTS FOUND TO BE IN AN UNHEALTHY CONDITION BY THE WETLAND SPECIALIST OR LANDSCAPE ARCHITECT. ALL REPLACEMENTS SHALL BE OF THE SAME KINDS AND SIZE OF PLANTS SPECIFIED IN THE PLANT LIST.
27. WETLAND REPLICATION AREAS WILL BE INSPECTED IN ACCORDANCE WITH THE SPECIFICATIONS OF ITEM 755.35 INLAND WETLAND REPLICATION AND ITEM 755.76 WETLAND MONITORING REPORTS TO IDENTIFY INVASIVE SPECIES AND A REPORT DETAILING TO RELATIVE SUCCESS OF THE MITIGATION PLAN IN TERMS OF BOTH THE HEALTH AND SURVIVAL OF WETLAND PLANTINGS SHALL BE PREPARED.
28. DURING AND AFTER THE FIRST AND SECOND GROWING SEASON, THE SUCCESS OF THE VEGETATIVE GROWTH WILL BE REVIEWED AND EVALUATED. ADDITIONAL VEGETATION WILL BE PLANTED AS NECESSARY TO REPLACE STRESSED OR MISSING VEGETATION AND TO ACHIEVE THE 75% SURVIVAL RATE SPECIFIED IN THE SPECIAL PROVISIONS.

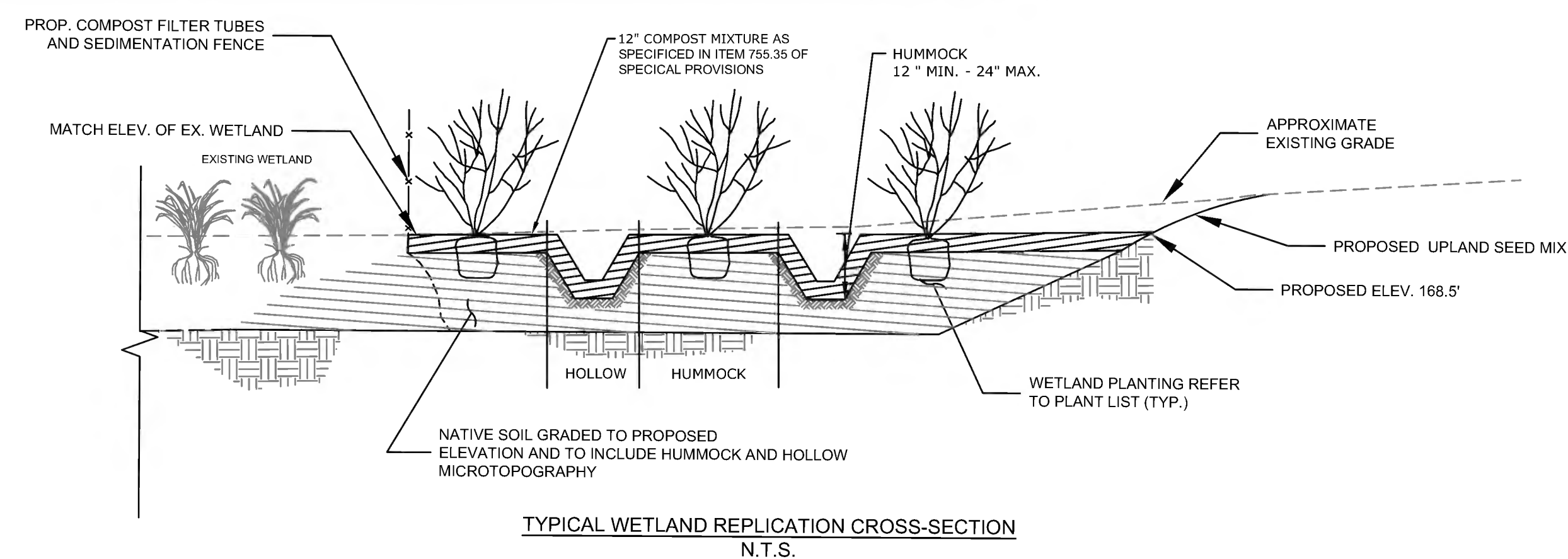
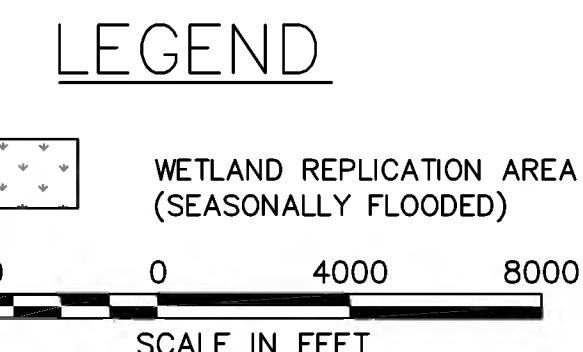
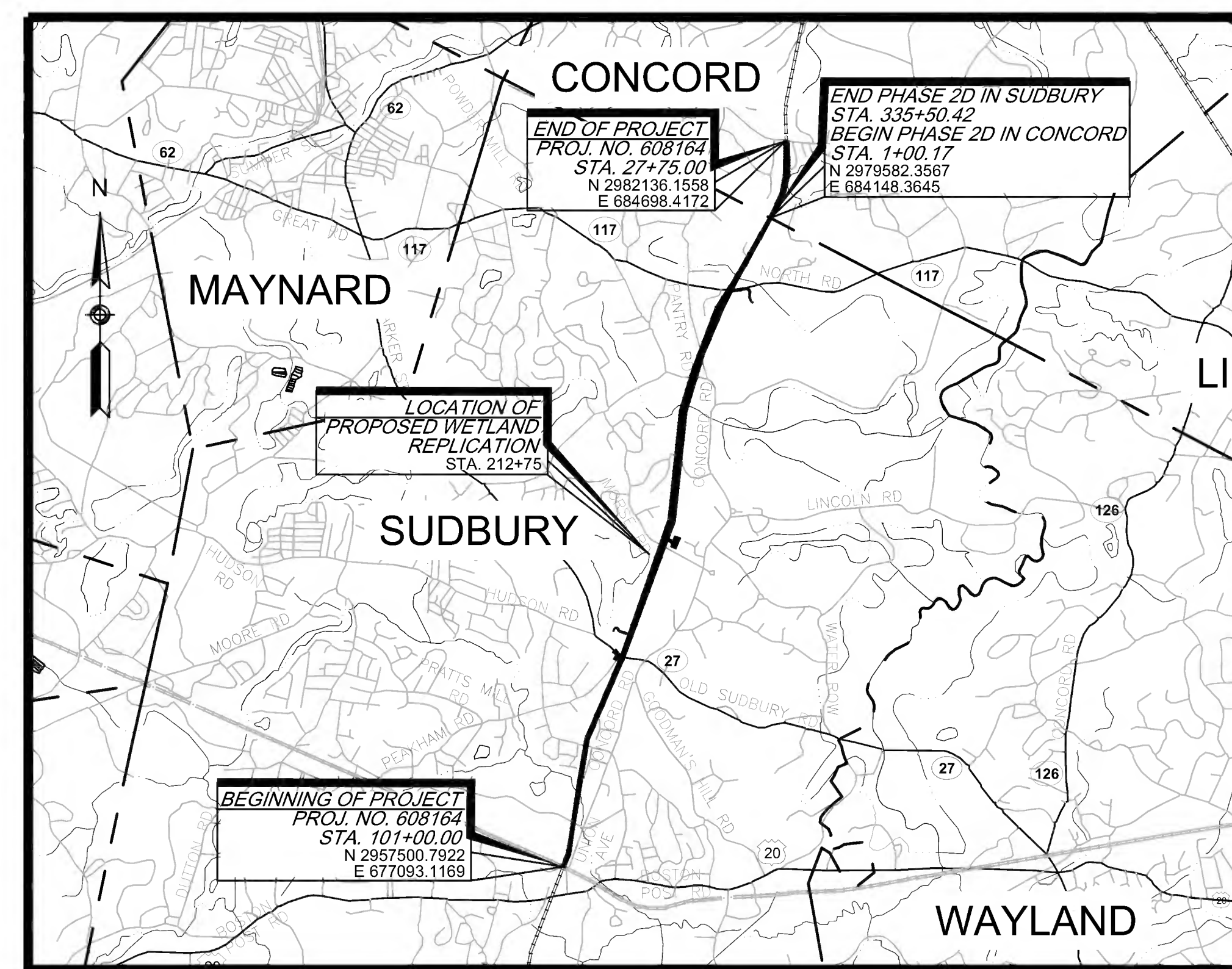
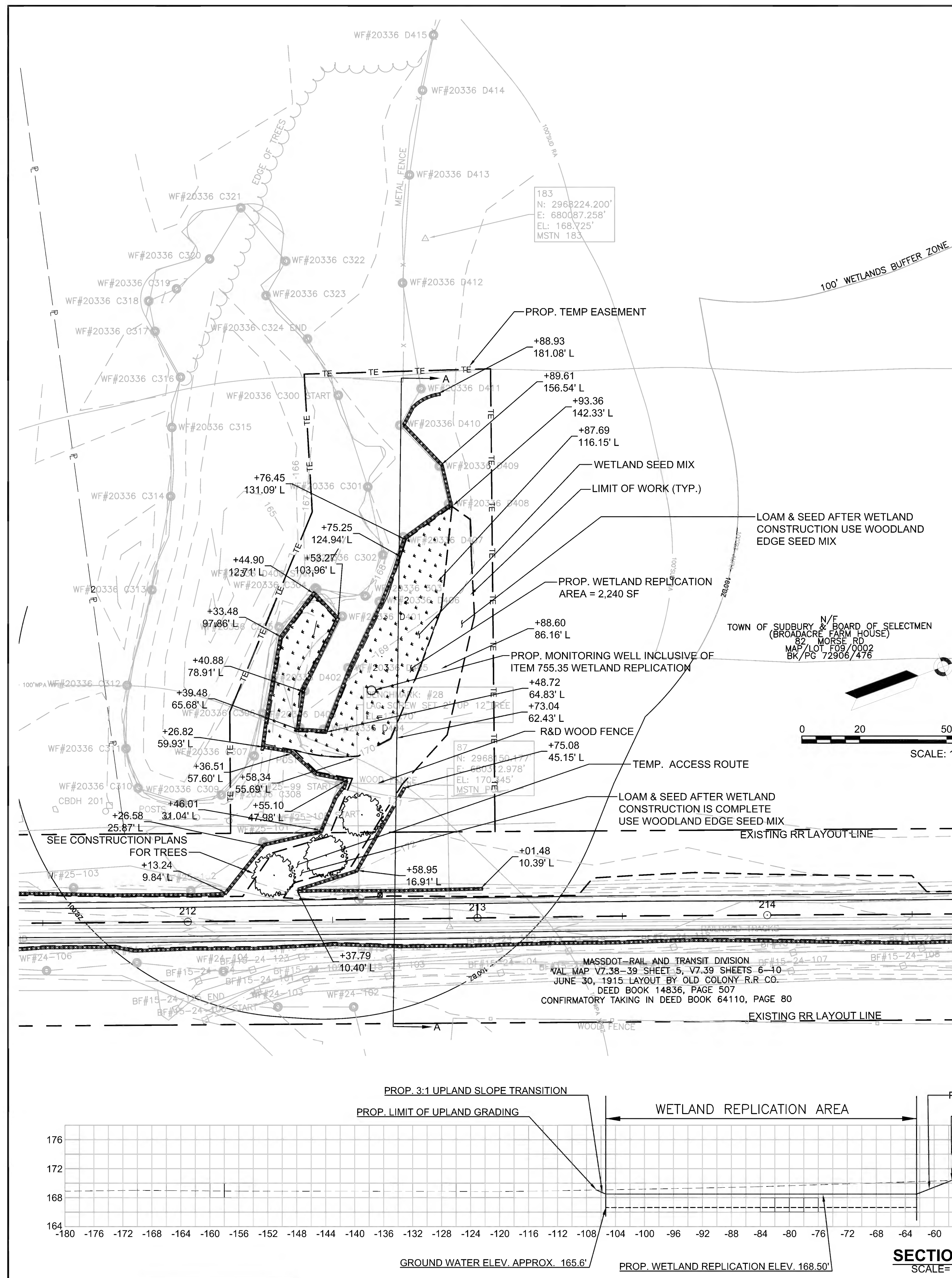

WETLAND REPLICATION AREA PLANT LIST

SYMBOL	QUANTITY	BOTANICAL NAME	COMMON NAME	SIZE	COMMENTS
TREES					
AR	8	ACER RUBRUM	RED MAPLE	4'-6' HT.	10' O.C.
BA	5	BETULA ALLEGHANIENSIS	YELLOW BIRCH	4'-6' HT.	10' O.C.
FP	3	FRAXINUS PENNSYLVANICA	GREEN ASH	4'-6' HT.	10' O.C.
UA	3	ULMUS RUBRA	SLIPPERY ELM	4'-6' HT.	10' O.C.
SHRUBS					
CR	6	CLETHRA ALNIFOLIA	SWEET PEPPERBUSH	2'-3' HT.	10' O.C. GROUPS OF 3
IV	6	ILEX VERTICILLATA	WINTERBERRY HOLLY	2'-3' HT.	10' O.C. GROUPS OF 3
LB	6	LINDERA BENZOIN	SPICEBUSH	2'-3' HT.	10' O.C. GROUPS OF 3
VC	6	VACCINIUM CORYMBOSUM	HIGHBUSH BLUEBERRY	2'-3' HT.	10' O.C. GROUPS OF 3
VD	6	VIBURNUM DENTATUM	NORTHERN ARROWWOOD	2'-3' HT.	10' O.C. GROUPS OF 3
VL	6	VIBURNUM LENTAGO	NANNYBERRY	2'-3' HT.	10' O.C. GROUPS OF 3

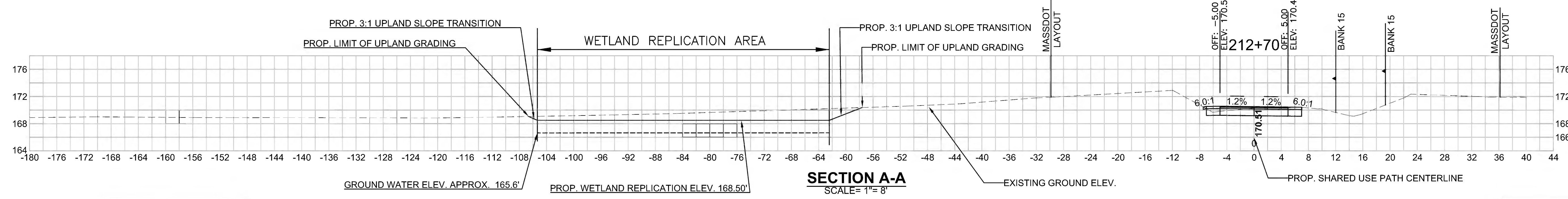

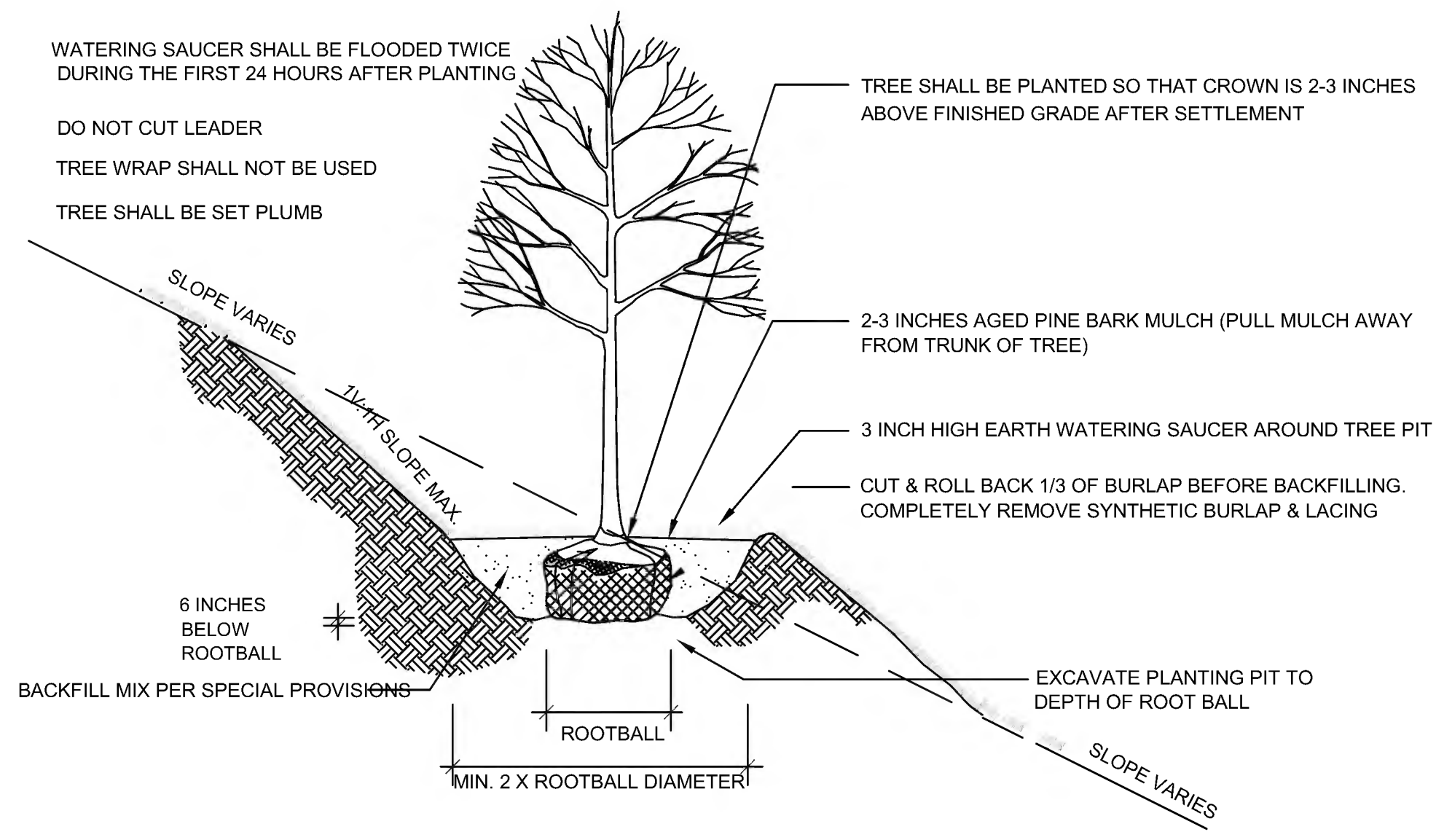

1 DECIDUOUS TREE PLANTING (SLOPE)
SCALE: N.T.S.

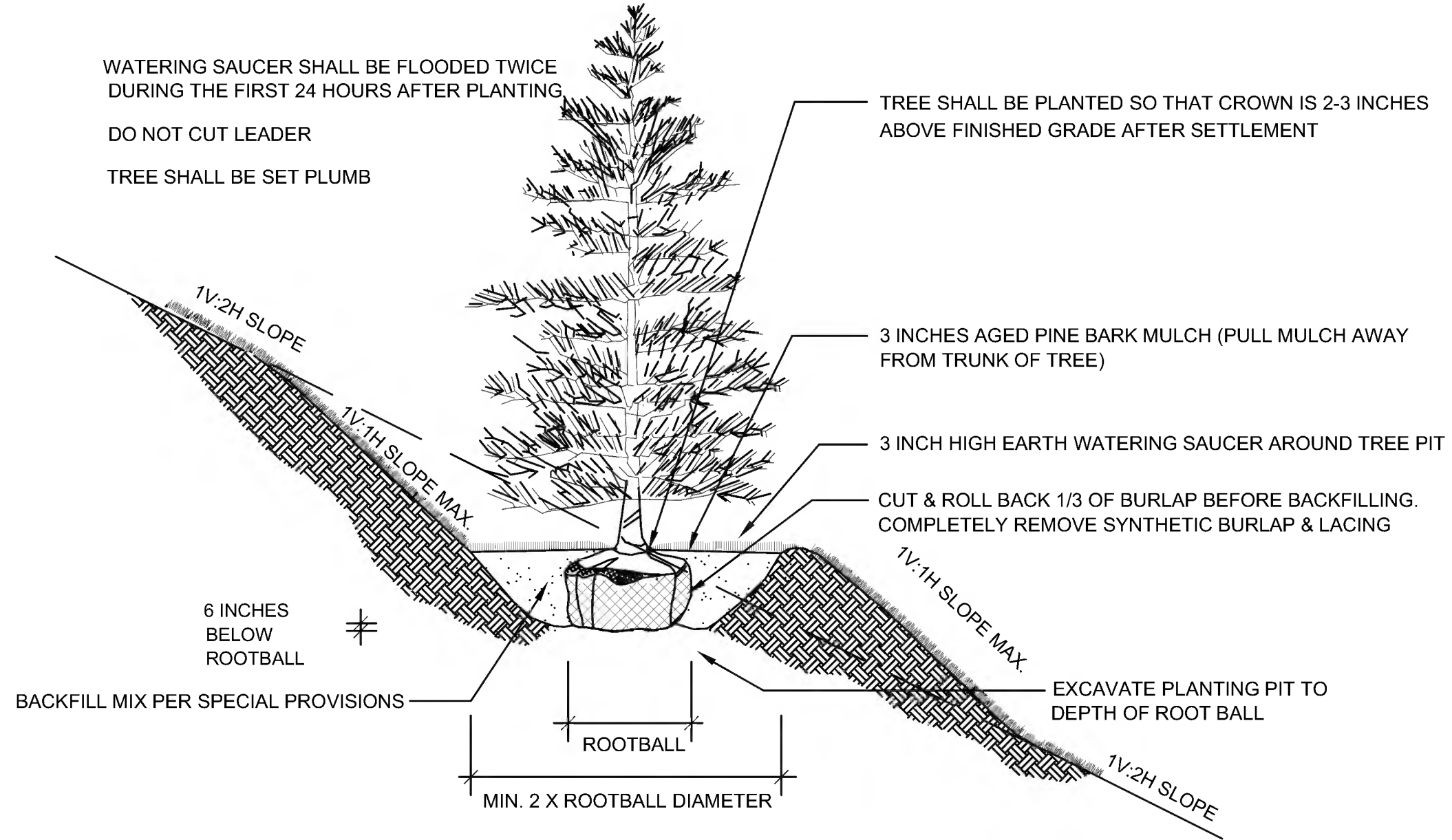

2 EVERGREEN TREE PLANTING (SLOPE)
SCALE: N.T.S.

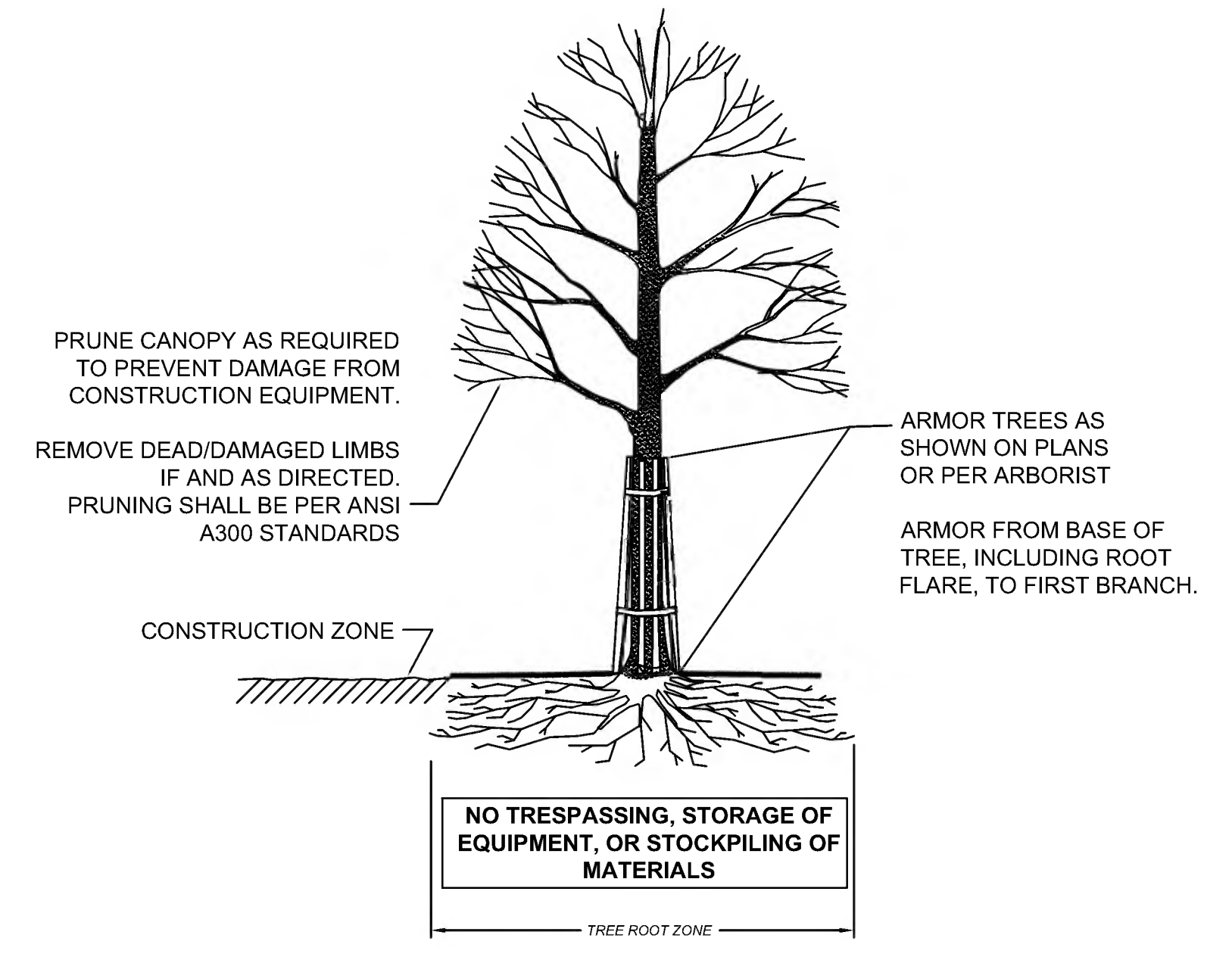

3 INDIVIDUAL TREE PROTECTION
SCALE: N.T.S.

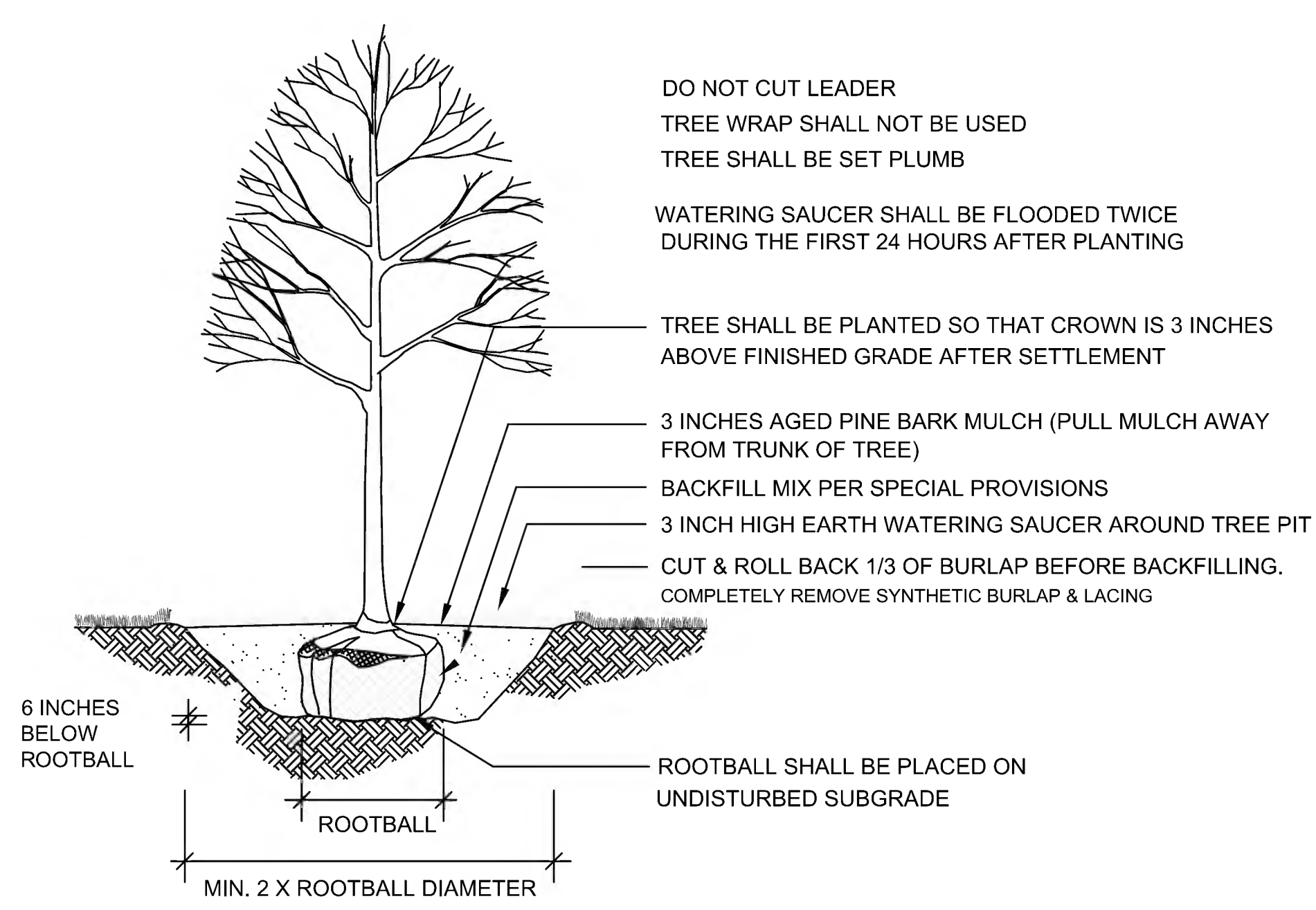

4 DECIDUOUS TREE PLANTING
SCALE: N.T.S.

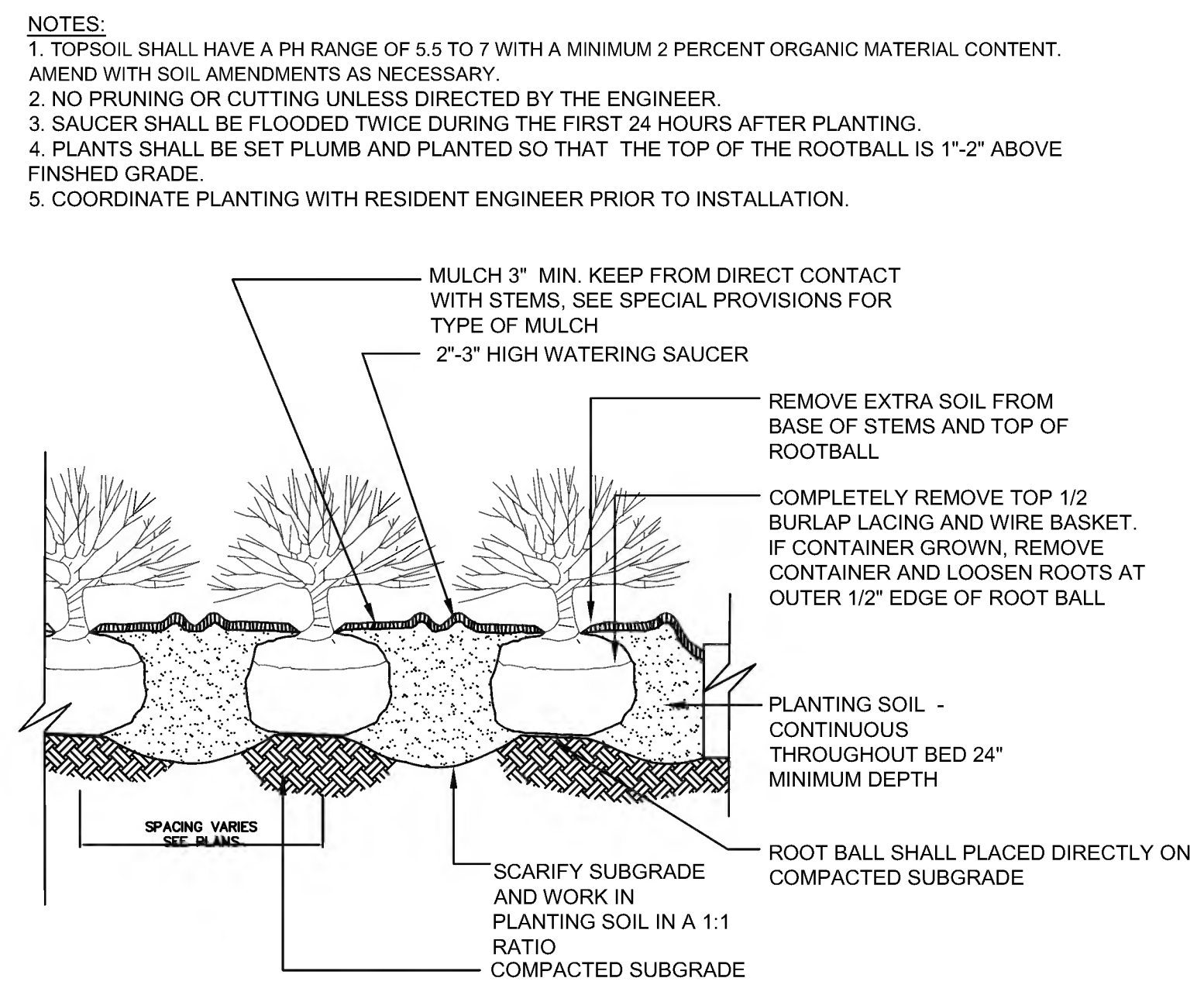

5 SHRUB AND PERENNIAL PLANTING
SCALE: N.T.S.

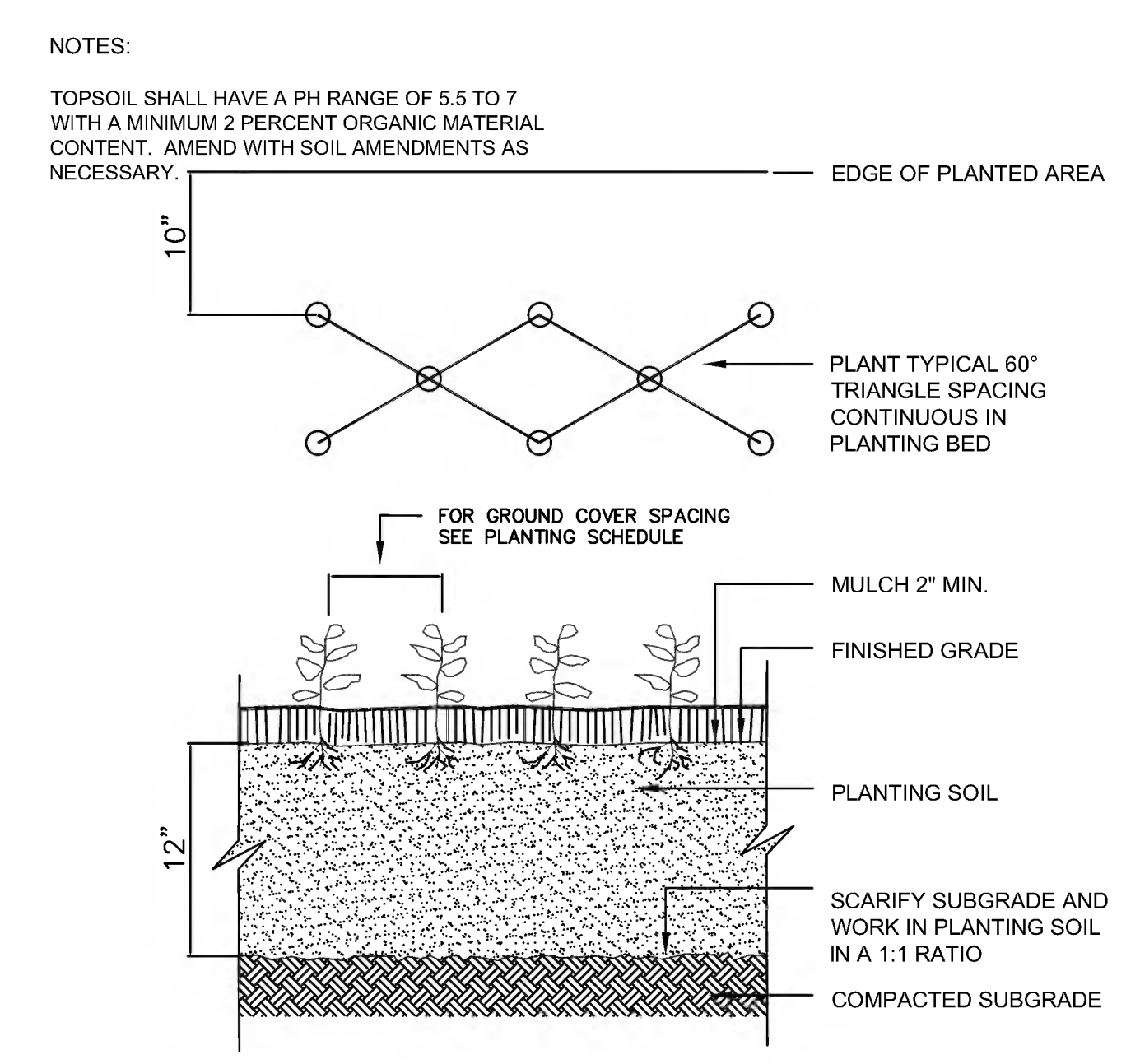

6 GROUNDCOVER PLANTING
SCALE: N.T.S.

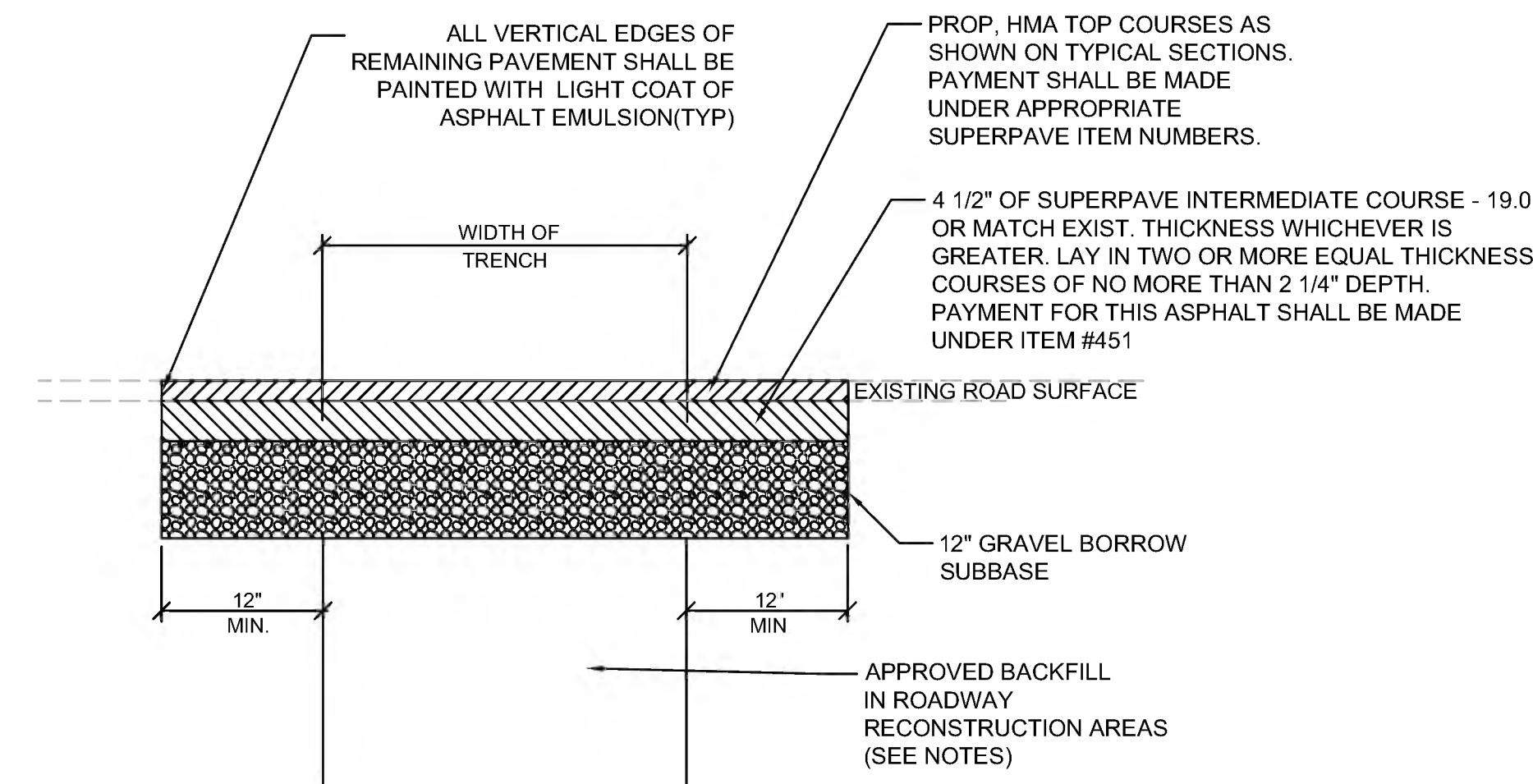

NOTES:
 OVERLAY AREAS: THE TRENCH SHALL BE REPAIRED TO THE TOP OF THE BASE COURSE. THE TOP COURSES SHALL BE PLACED WITH OVERLAY OF THE ROADWAY
 ROADWAY TRENCHING OUTSIDE OF FULL DEPTH AND OVERLAY: THE TRENCH SHALL BE REPAIRED WITH TOP COURSES INSTALLED WITH THE BASE COURSE.
 CONTROLLED DENSITY FILL MAY BE USED IN LIEU OF APPROVED BACKFILL IN PAVEMENT MILLING AND OVERLAY AREAS. **USE OF CONTROLLED DENSITY FILL TO BACKFILL TRENCHES SHALL BE APPROVED BY THE TOWN OF SUDBURY PRIOR TO PLACEMENT.**
 PERMANENT ASPHALT SHALL BE PAID FOR UNDER ITEM #451.

7 PERMANENT PAVEMENT TRENCH REPAIR IN ROADWAYS
 SCALE: N.T.S.

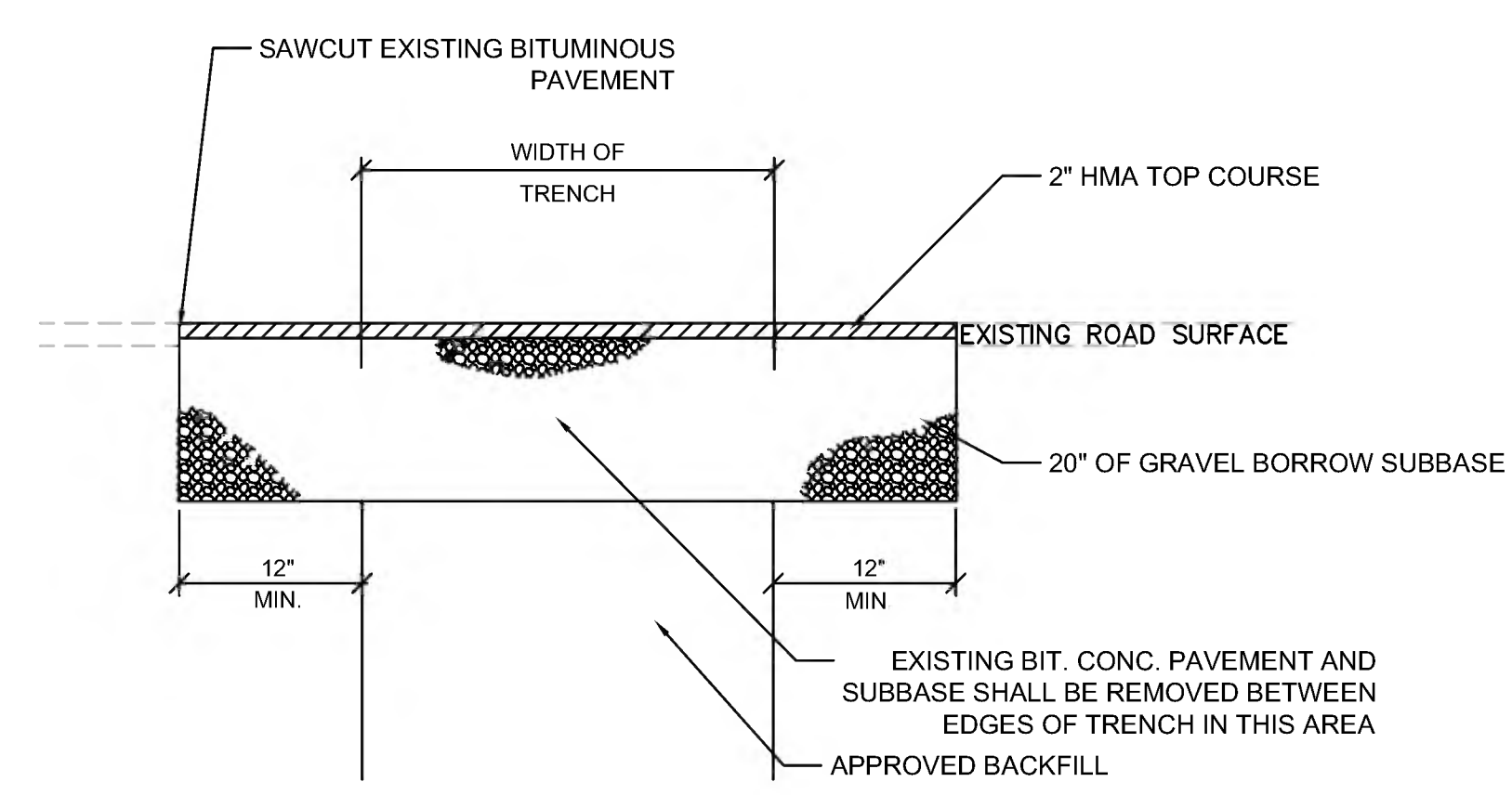

NOTES:
 THE TEMPORARY PAVEMENT TRENCH REPAIR SHALL BE USED DURING THE TIME BETWEEN COMPLETION OF THE UTILITY CONSTRUCTION AND CONSTRUCTION OF THE PROPOSED ROADWAY PAVEMENT STRUCTURE OR PERMANENT PAVEMENT TRENCH REPAIR.
 TEMPORARY ASPHALT SHALL BE PAID FOR UNDER ITEM #472

8 TEMPORARY PAVEMENT TRENCH REPAIR
 SCALE: N.T.S.

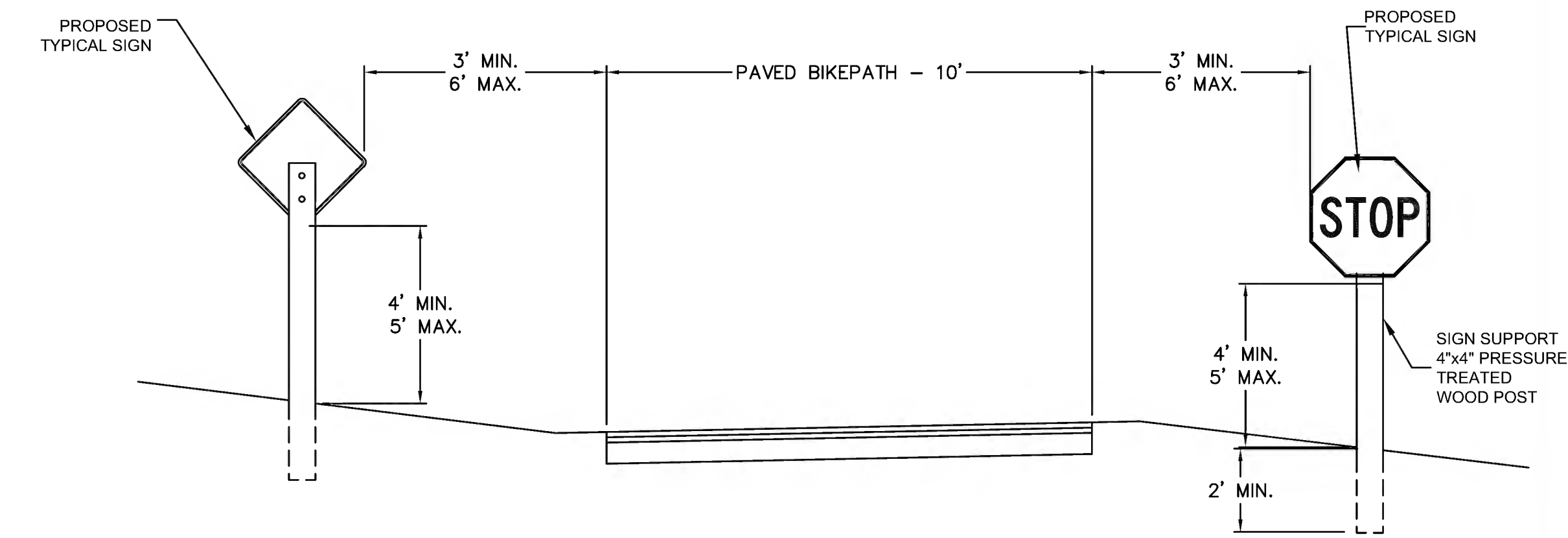

NOTES:
 1. ALL HARDWARE SHALL BE GALVANIZED.
 2. WOOD POSTS SHALL BE PAID FOR UNDER ITEM 847.11\"/>

9 SHARED-USE PATH TYPICAL SIGN PLACEMENT
 SCALE: N.T.S.

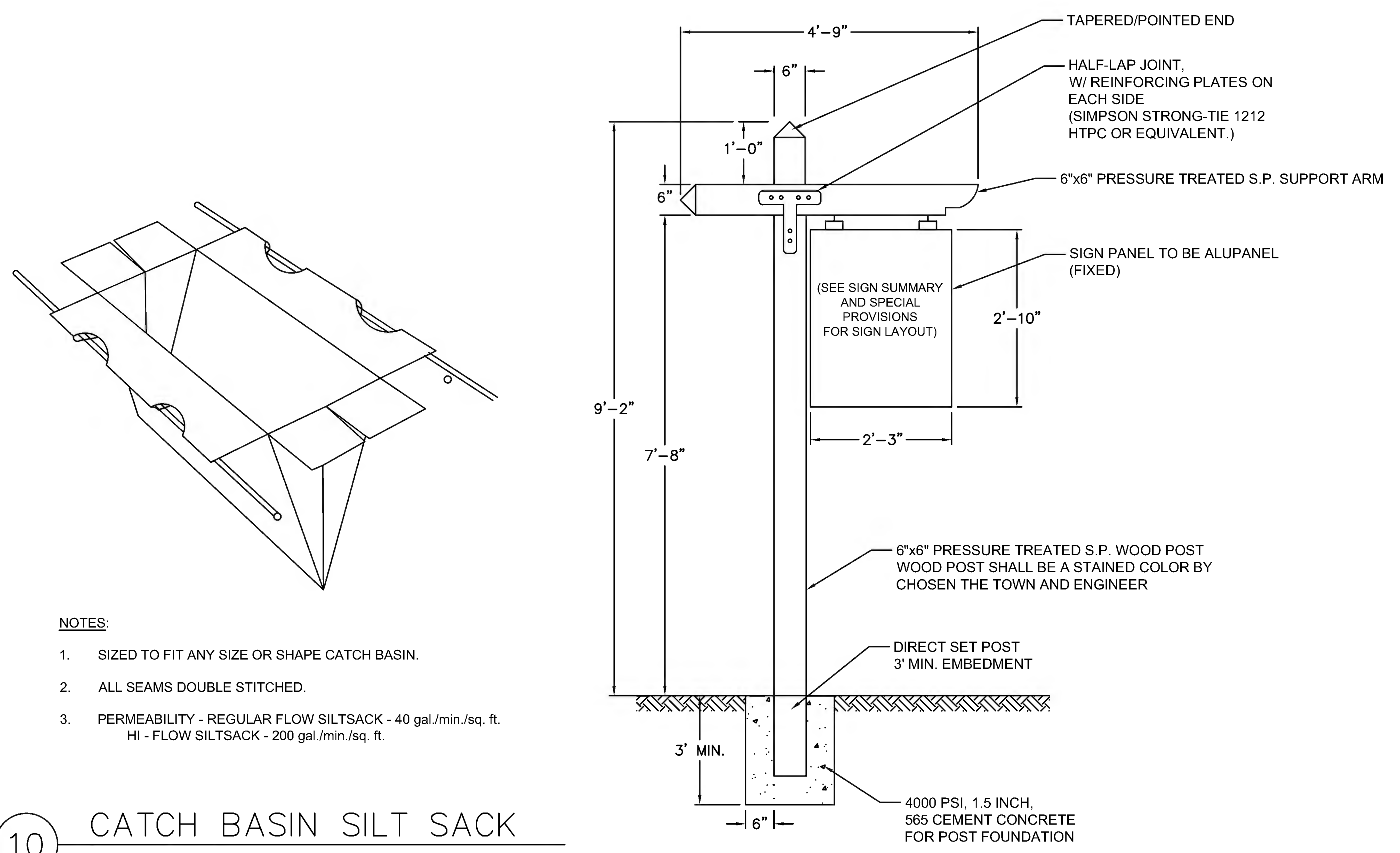

NOTES:
 1. SIZED TO FIT ANY SIZE OR SHAPE CATCH BASIN.
 2. ALL SEAMS DOUBLE STITCHED.
 3. PERMEABILITY - REGULAR FLOW SILTSACK - 40 gal./min./sq. ft. HI - FLOW SILTSACK - 200 gal./min./sq. ft.

10 CATCH BASIN SILT SACK
 SCALE: N.T.S.

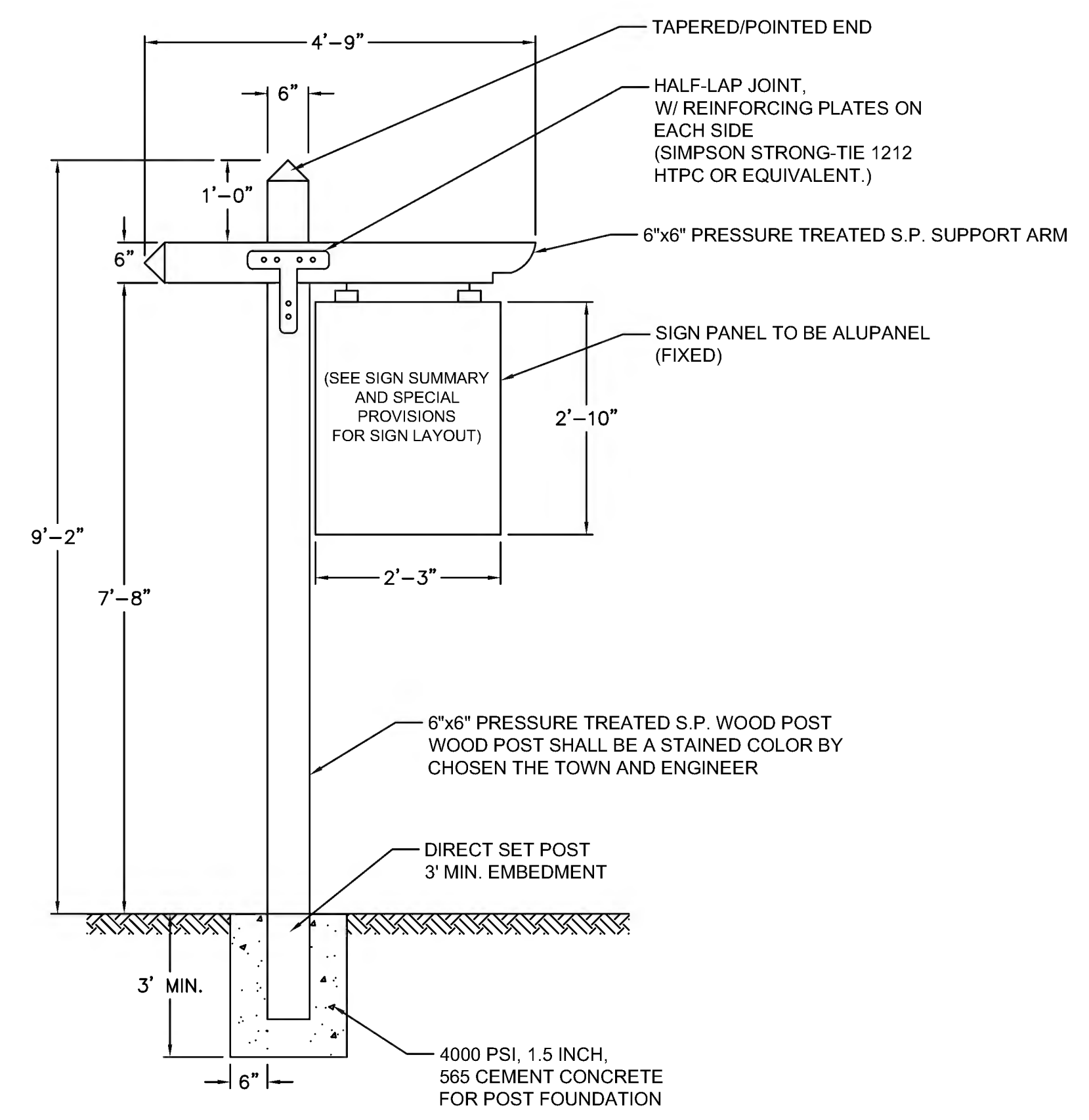

11 WAYFINDING SIGNS TYPE DS
 SCALE: N.T.S.

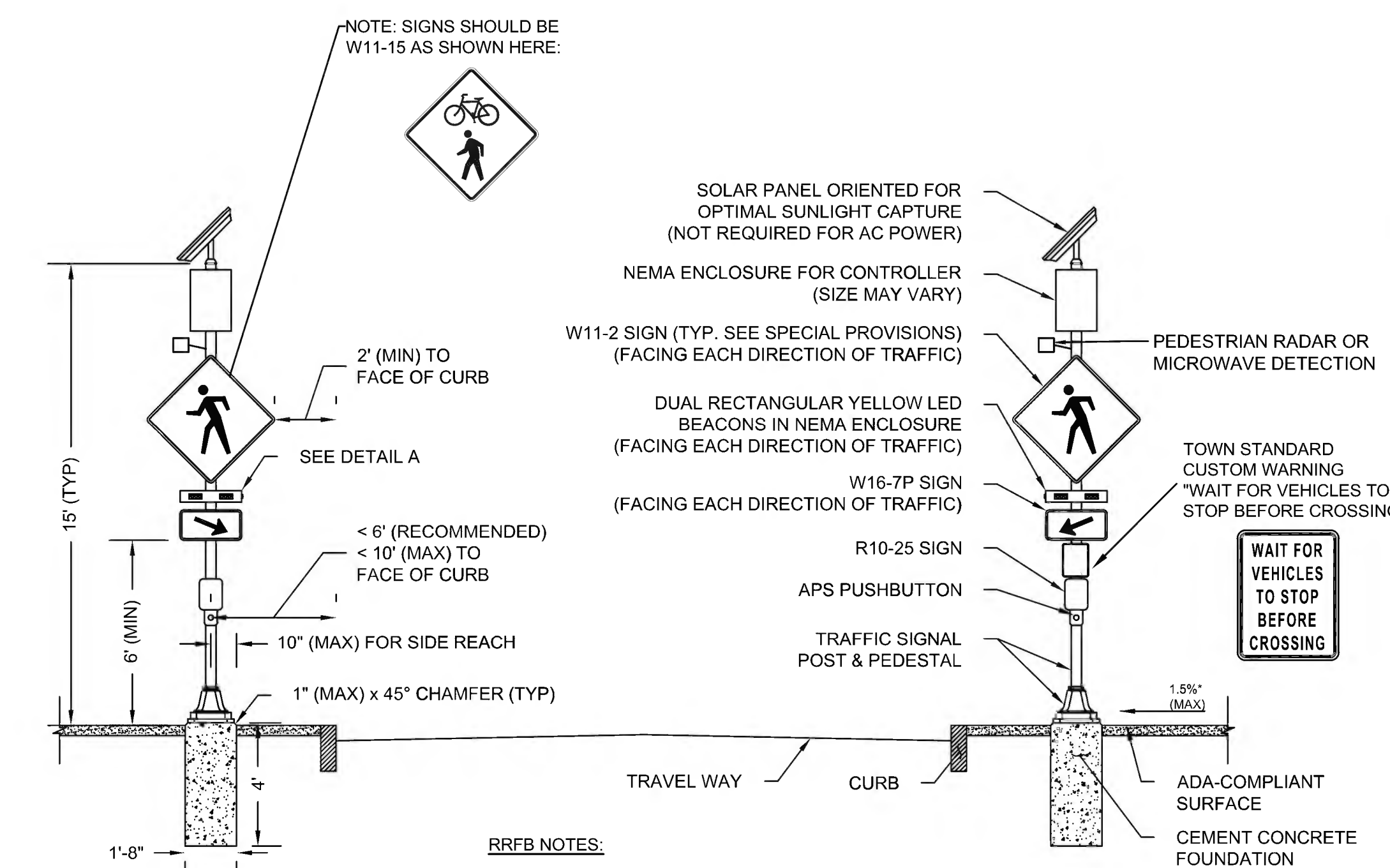

RRFB NOTES:
 1) PAYMENT FOR PRECAST FOUNDATION INCLUSIVE UNDER ITEM 824.221 & 824.222
 2) ALL POSTS, BRACKETS, AND HARDWARE SHALL BE FACTORY GLOSS BLACK.
 3) RRFB SHALL BE EQUIPPED WITH BOTH RADAR/MICROWAVE DETECTION AND TRADITIONAL PUSH BUTTON AS SECONDARY ACTIVATION MEASURE.

NOTES:
 1. CROSSWALK AND ADA-COMPLIANT RAMPS NOT SHOWN. SEE PLANS FOR LOCATIONS.
 2. REFER TO THE SPECIAL PROVISIONS FOR SIGN DIMENSIONS.
 3. ALL CONDUIT, PULL BOXES, SERVICE CONNECTIONS, AND EQUIPMENT GROUNDING REQUIRED FOR AC POWER IS NOT SHOWN IN THIS DETAIL AND SHALL BE PAID FOR SEPARATELY UNDER THEIR RESPECTIVE PAY ITEMS.
 4. ACCESS TO ALL PEDESTRIAN ACTUATED CONTROLS SHALL BE ADA/AAB COMPLIANT.
 5. 0.5% CONSTRUCTION TOLERANCE FOR CROSS-SLOPE.
 6. ALL RRFB'S SHALL HAVE BOTH BUTTONS AND DETECTION INSTALLED.

MAJOR ITEMS LIST
 2 CEMENT CONCRETE FOUNDATIONS PER 812.30.1
 2 15' TRAFFIC SIGNAL POSTS & PEDESTALS
 2 APS PUSHBUTTON SYSTEMS
 4 DUAL RECTANGULAR YELLOW LED BEACONS IN NEMA ENCLOSURES
 2 R10-25 SIGNS
 4 W11-2 SIGNS
 2 W16-7PR SIGNS
 2 W16-7PL SIGNS
 2 SOLAR PANEL SYSTEMS (NOT REQUIRED FOR AC POWER)
 2 NEMA ENCLOSURES FOR ALL COMPONENTS NEEDED TO MEET FUNCTIONAL REQUIREMENTS PER SPECIAL PROVISIONS
 2 BATTERY SYSTEMS (NOT REQUIRED FOR AC POWER)
 2 TOWN STANDARD CUSTOM WARNING SIGNS PLUS ALL MOUNTING AND SUPPORTING HARDWARE AND WIRING NECESSARY TO COMPLETE A WORKING SYSTEM.
 2 PEDESTRIAN RADAR OR MICROWAVE DETECTION

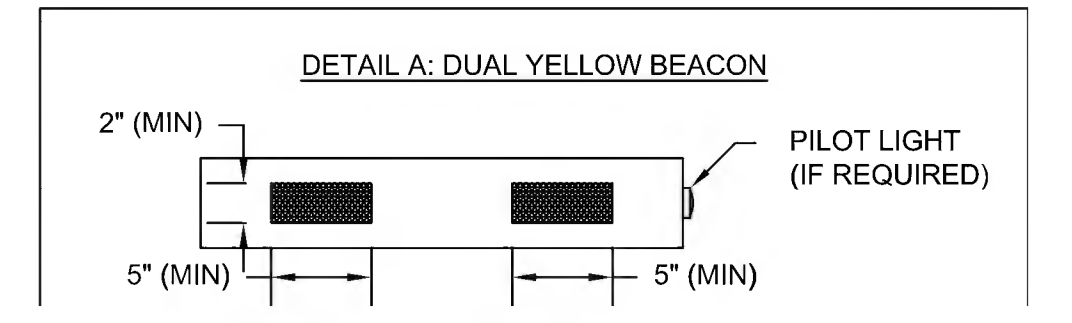

12 RECTANGULAR RAPID FLASHING BEACON (RRFB)
 SCALE: N.T.S.

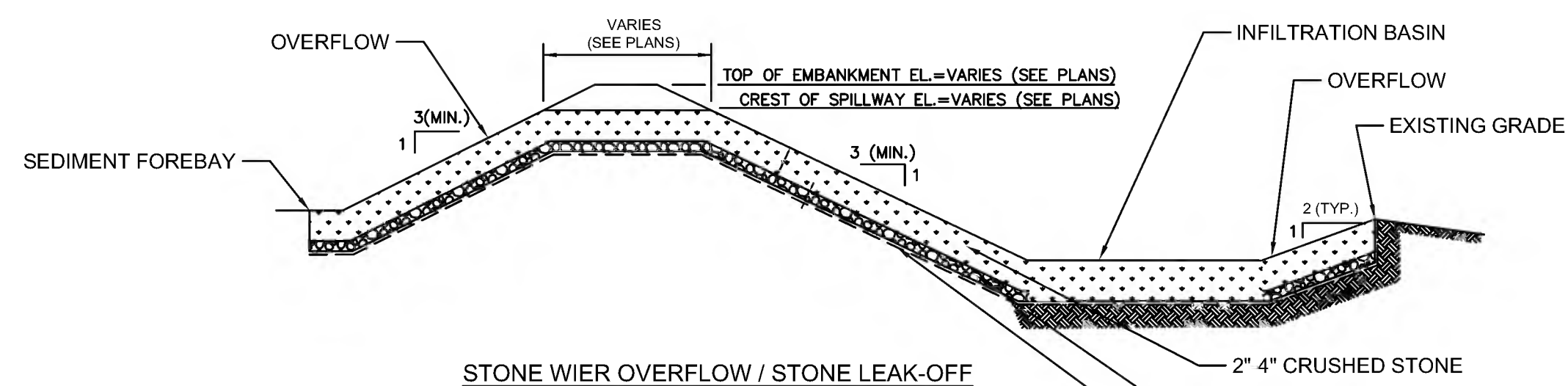

NOTES:

1. IMPERVIOUS MATERIAL FOR USE IN BASIN EMBANKMENT AREAS AND WHERE SHOWN ON THE PLANS SHALL BE COMPOSED OF CLAYS, SILTY CLAYS, OR CLAYEY SILTS. THE SOIL SHALL BE FREE OF RUBBISH, ICE, VEGETATIVE MATTER, LOAM, OR OTHER DEBRIS AND HAVE THE FOLLOWING GRADATION AS DEFINED BY A STANDARD SIEVE TEST (ASTM D422):

MIN. PERCENT PASSING (BY WT.)	SEIVE SIZE
100	3.5"
80-100	3/4"
40-90	No. 4
30-85	No. 40
25-75	No. 200

2. PERVIOUS BACKFILL MATERIAL FOR USE IN FILL AREAS ASSOCIATED WITH BASIN EMBANKMENTS SHALL BE COMPOSED OF ORDINARY BORROW MATERIAL (ITEM 150.) OR EXCAVATED MATERIAL FROM THE SITE DEEMED RE-USEABLE BY THE ENGINEER. SATISFACTORY ON-SITE MATERIAL SHALL HAVE SOIL CLASSIFICATION GROUPS OF GW, GP, GM, SW, SP, AND SM ACCORDING TO ASTM D 2487, OR A COMBINATION OF THESE GROUPS AND SHALL BE FREE OF ROCK OR GRAVEL LARGER THAN 3 INCHES (75 MM) IN ANY DIMENSION, DEBRIS, WASTE, FROZEN MATERIALS, VEGETATION, AND OTHER DELETERIOUS MATTER.

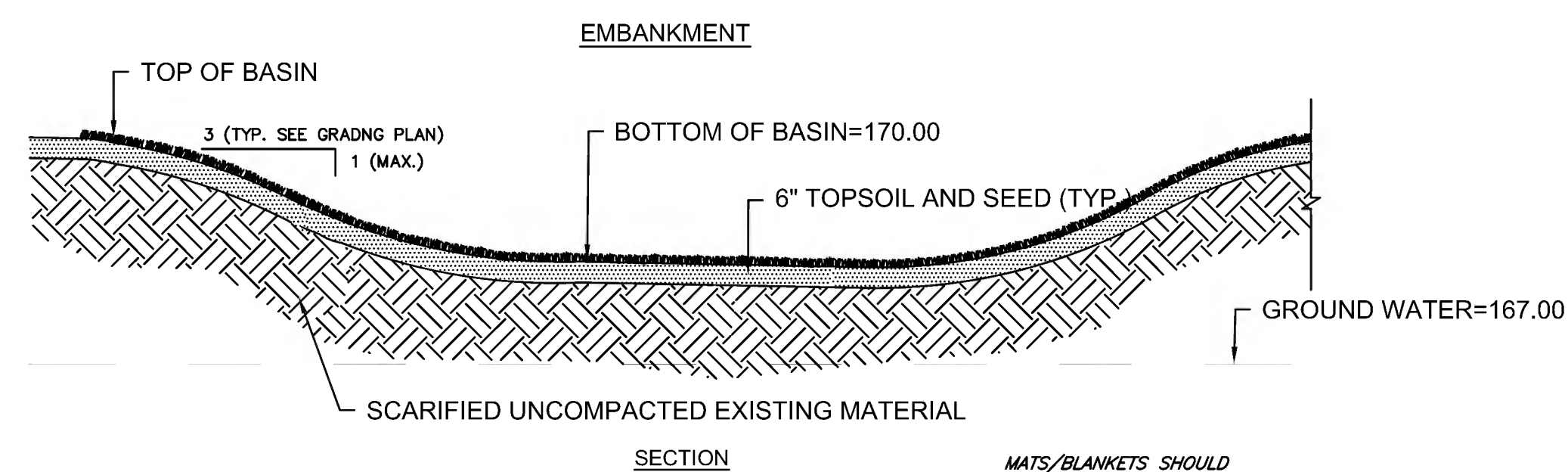

13 INFILTRATION BASIN
SCALE: N.T.S.

COMPOST FILTER TUBE

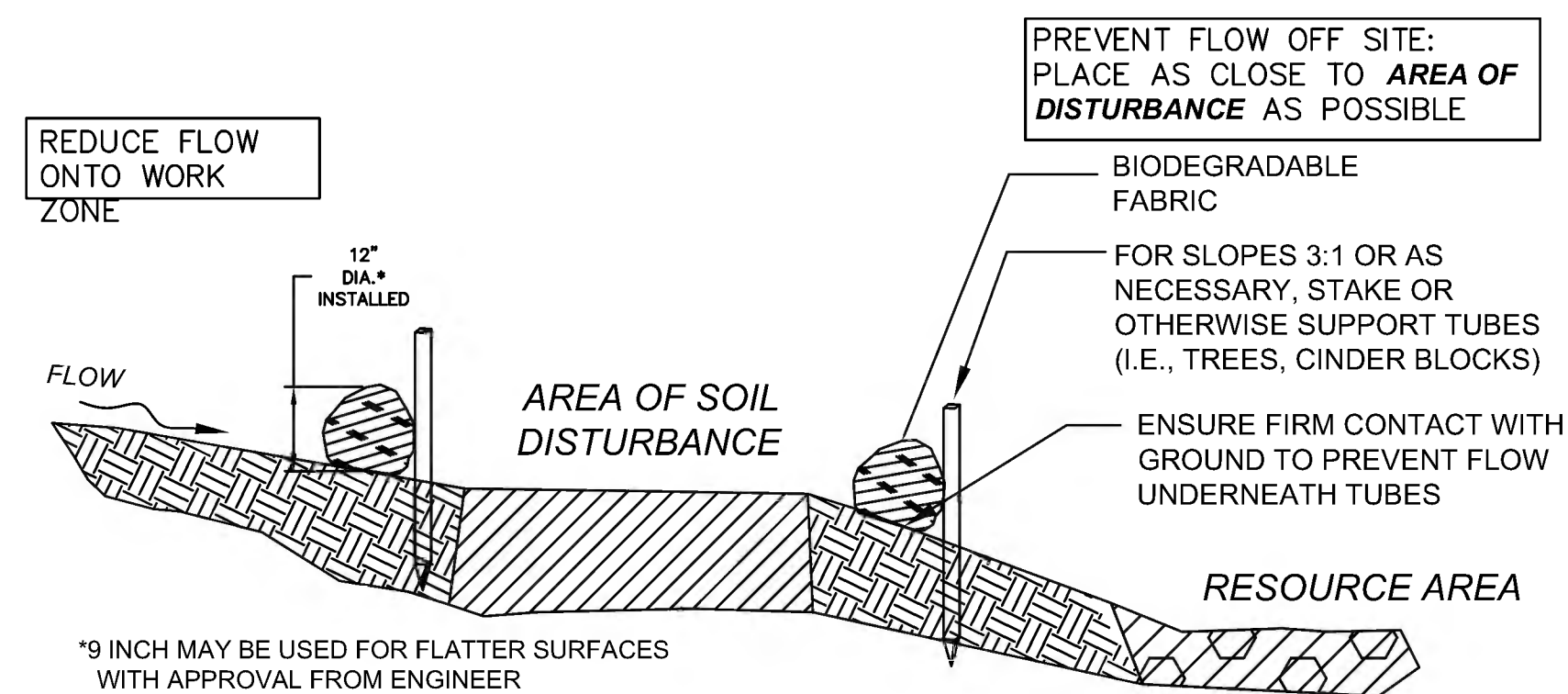

12 INCH STRAW WATTLE

TO BE USED ONLY ON FLAT SURFACES WITH LOW FLOW

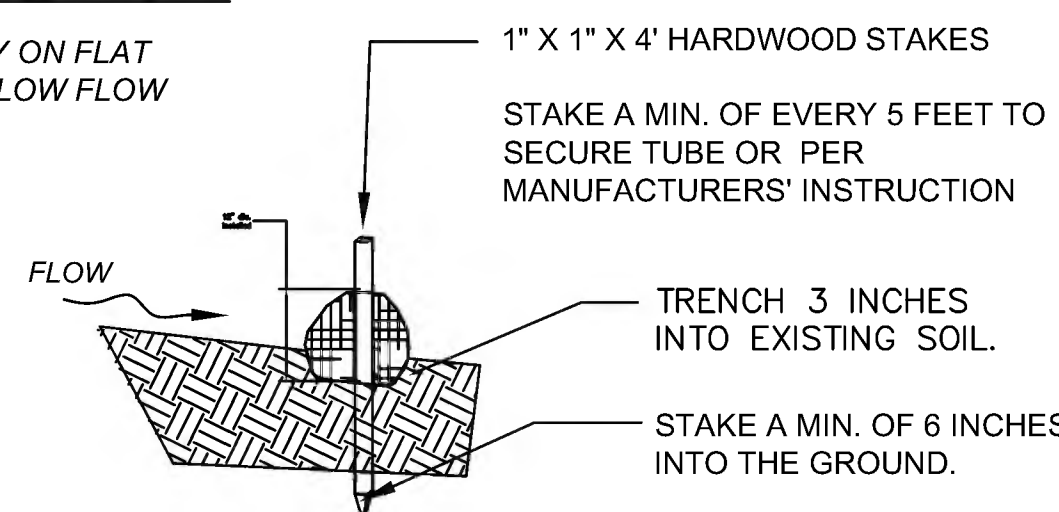

SECTION

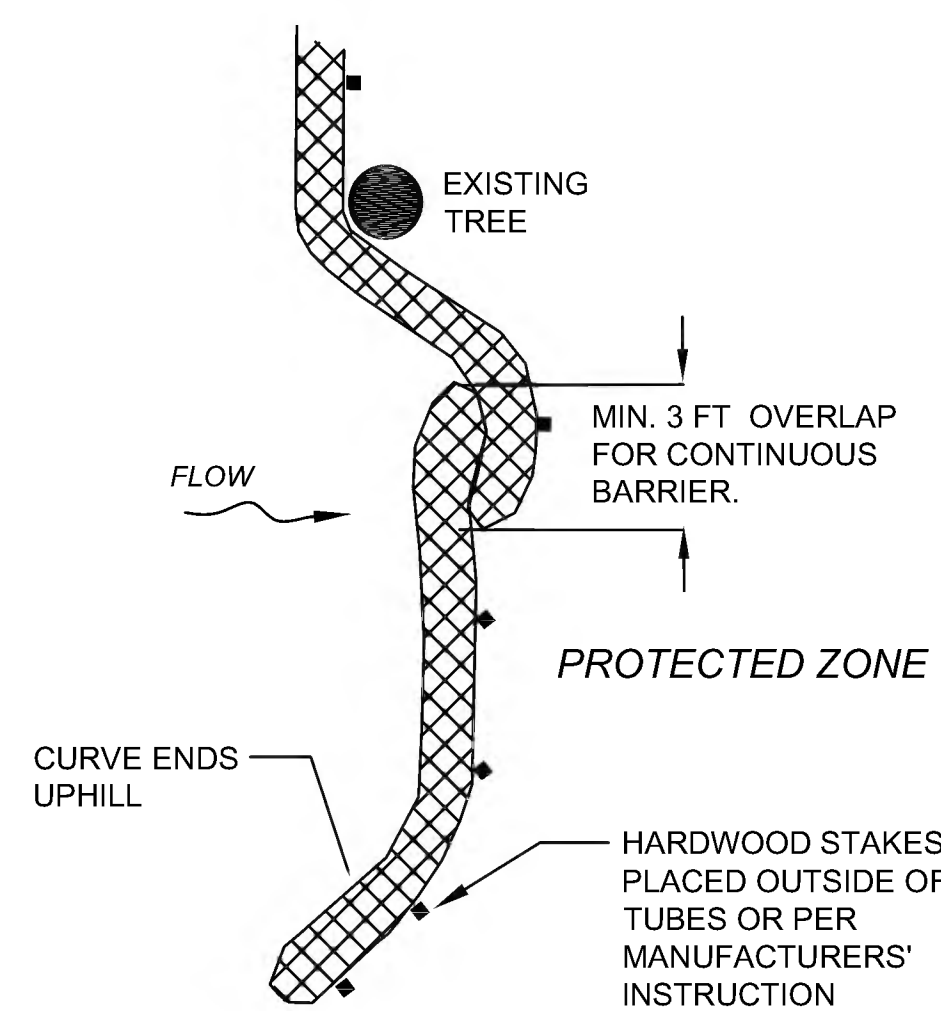

PLACE TUBE ALONG CONTOURS AND PERPENDICULAR TO FLOW.
ADJUST LOCATION AS REQUIRED FOR OPTIMUM EFFECTIVENESS. DO NOT INSTALL IN WATERWAYS.
PLACE STAKES AS NEEDED TO SECURE TUBES IN PLACE.

PLAN VIEW

14 MATTING FOR EROSION CONTROL
SCALE: N.T.S.

NOTES:
1. MATTING FOR EROSION CONTROL MUST BE MADE FROM 100% BIODEGRADABLE MATERIAL.
2. STAPLES OR STAKES MAY BE USED TO SECURE THE MATTING. THE STAPLES OR STAKES MUST BE MADE FROM A 100% BIODEGRADABLE MATERIAL.

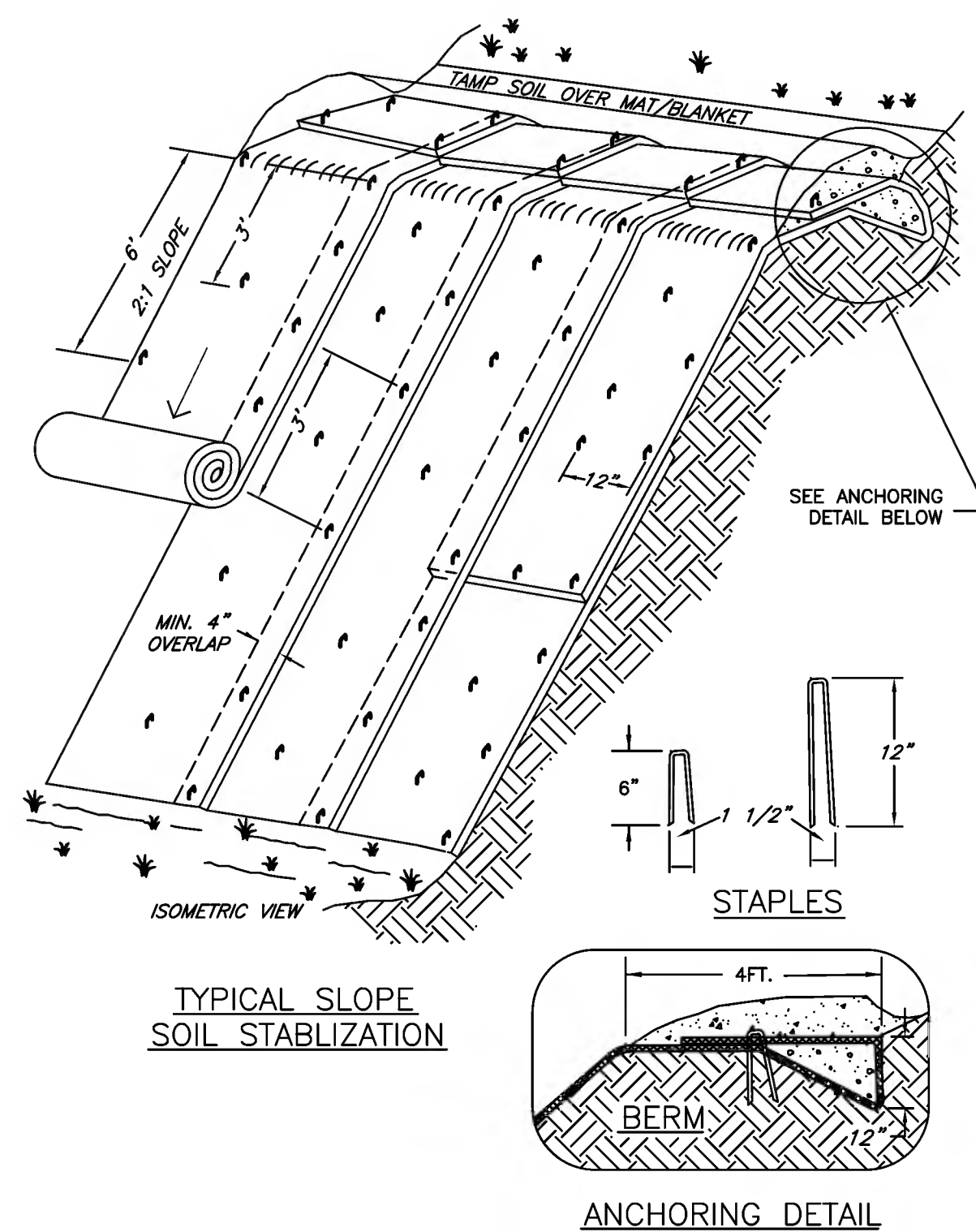

15 MODIFIED ROCK FOR SWALE ENDS (5'X5')
SCALE: N.T.S.

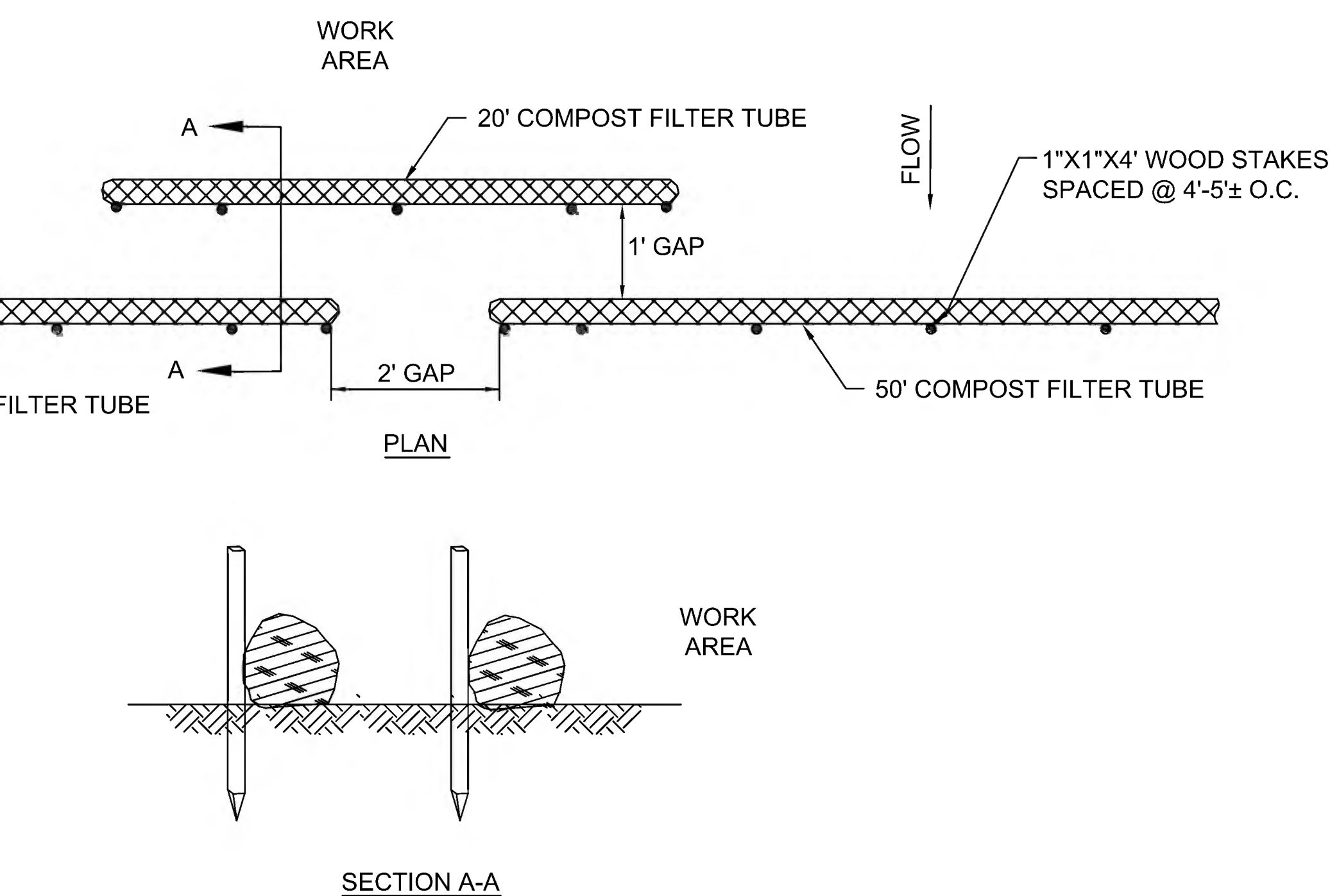
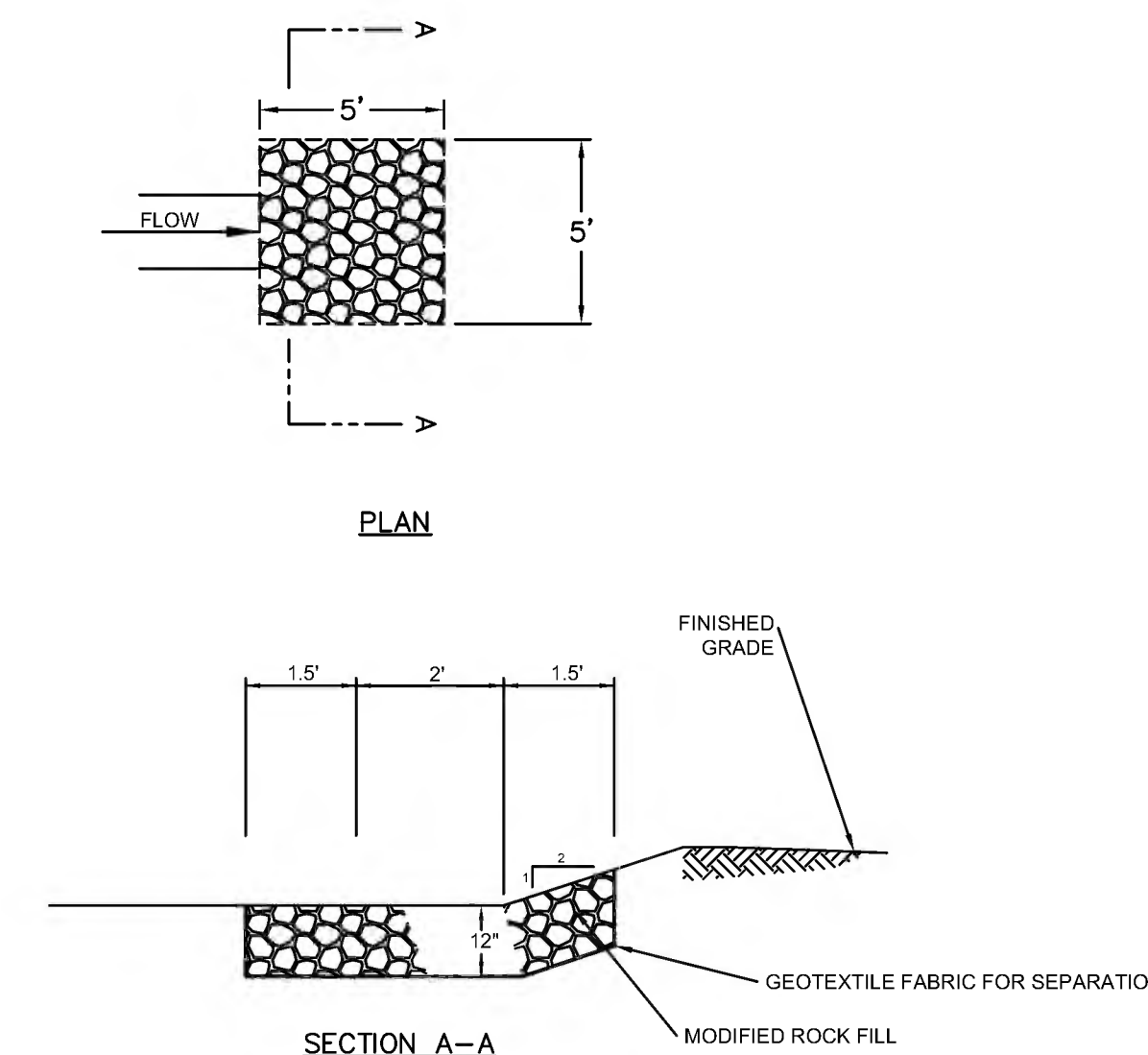

NOTES:
1. SYNCOPATED COMPOST FILTER TUBES SHALL BE USED WHEN BORDERING VERNAL POOLS AS SHOWN ON THE PLANS.

16 SEDIMENT BARRIERS – COMPOST FILTER TUBES
SCALE: N.T.S.

17 SYNCOPATED SEDIMENT CONTROL BARRIER
SCALE: N.T.S.

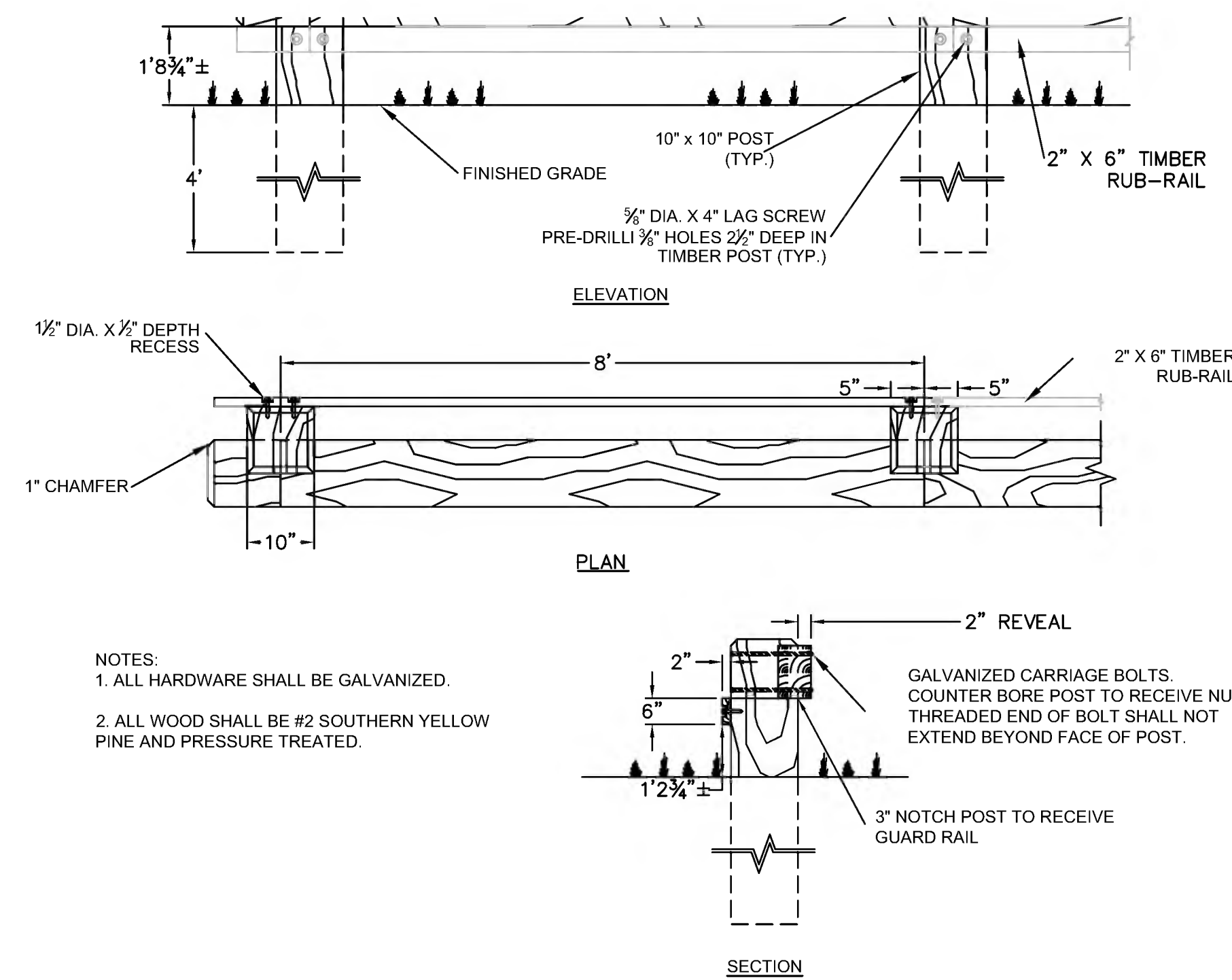

18 **TIMBER POST GUARDRAIL**
SCALE: N.T.S.

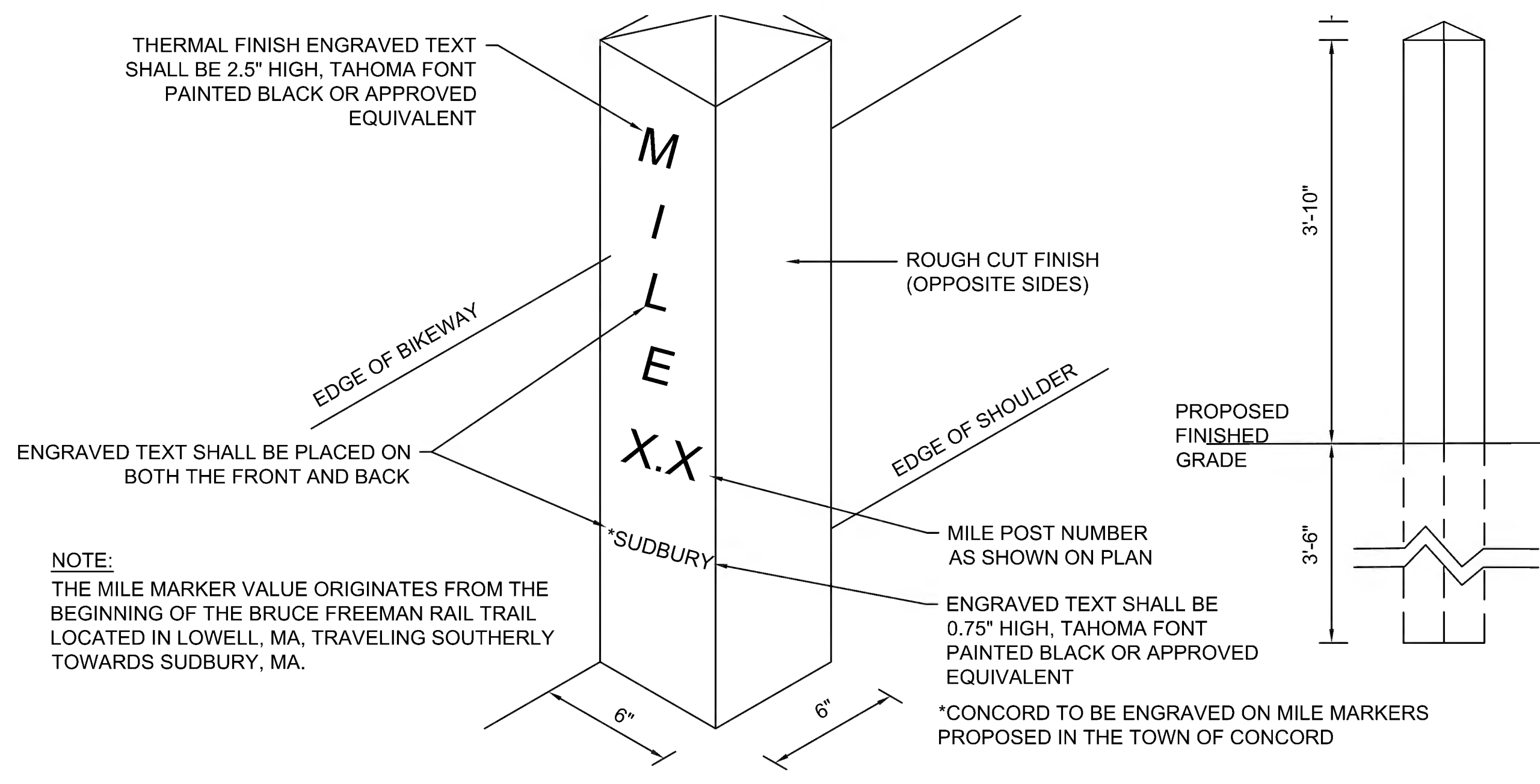

19 **GRANITE MILE MARKER**
SCALE: N.T.S.

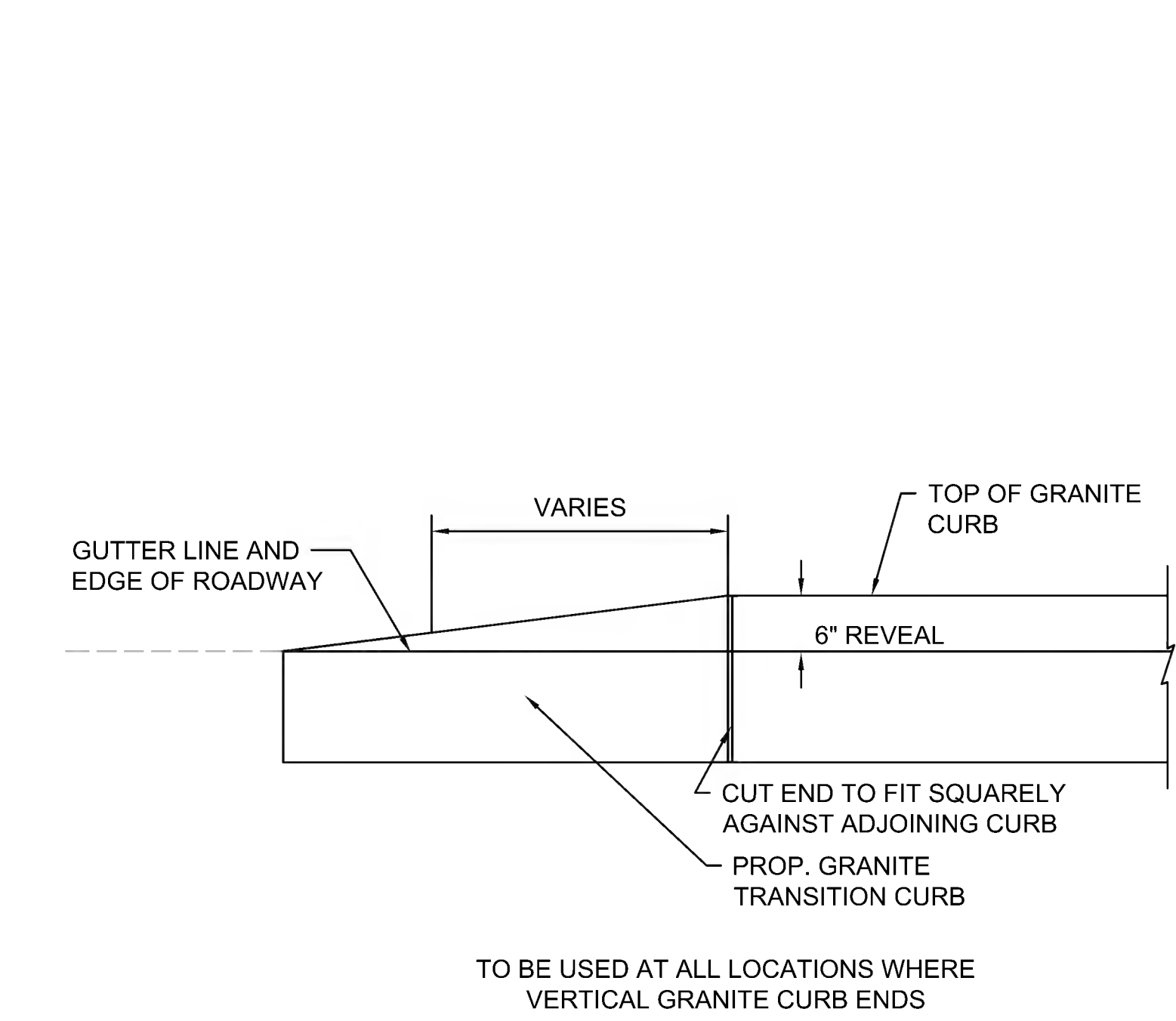

20 **TRANSITION CURB DETAIL**
SCALE: N.T.S.

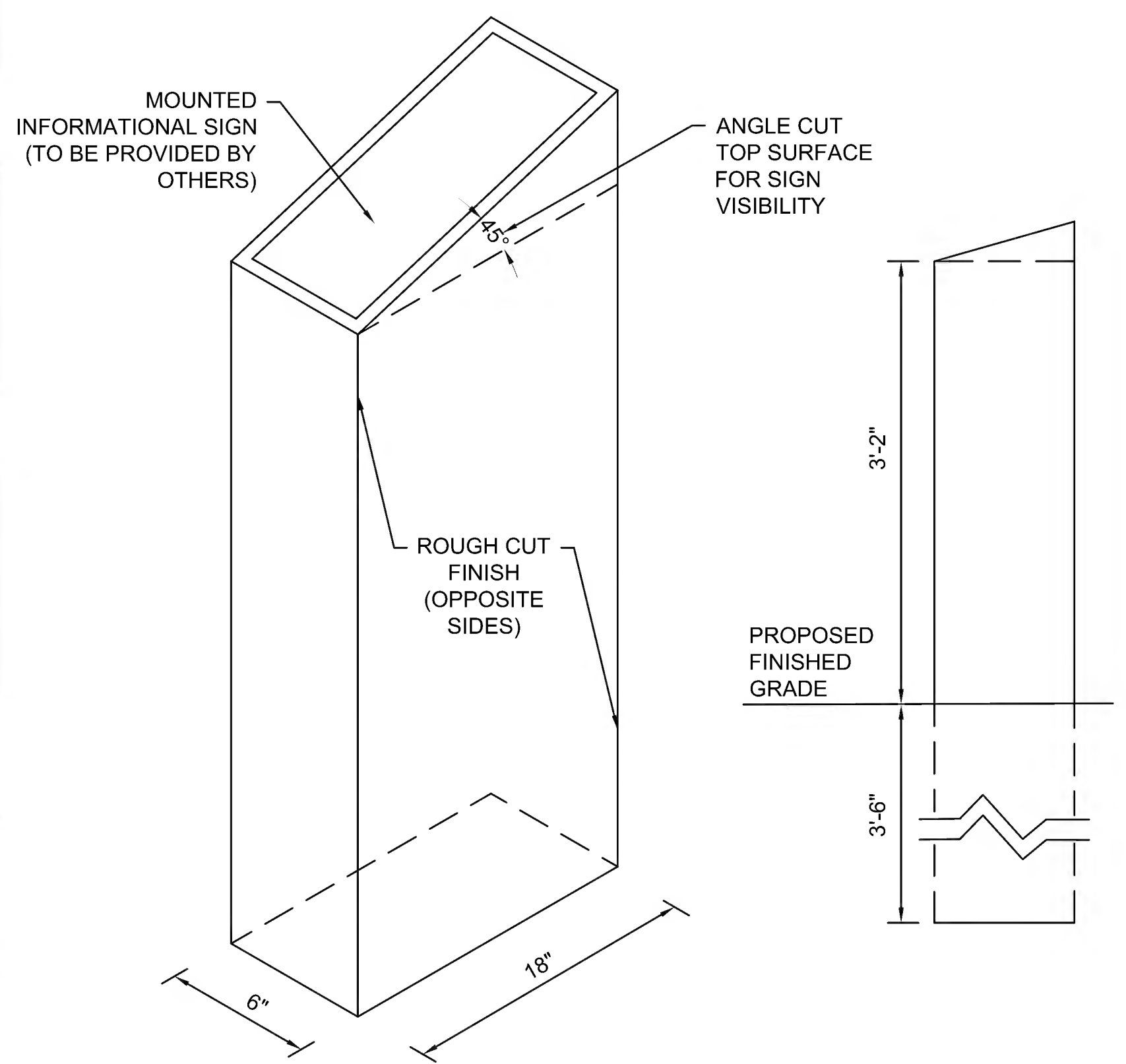

21 **GRANITE POST INTERPRETIVE SIGN**
SCALE: N.T.S.

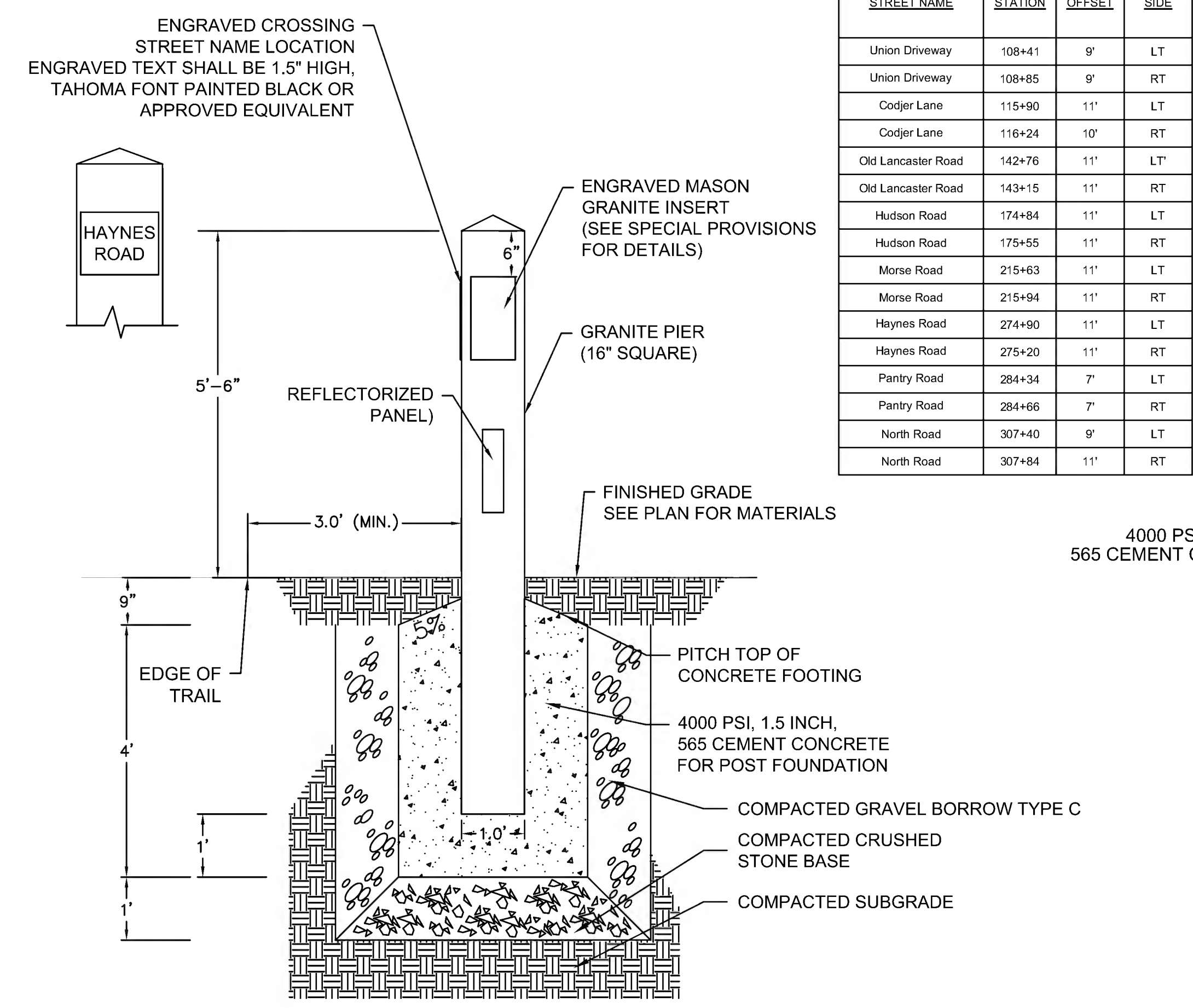

22 **GRANITE BRUCE FREEMAN RAIL TRAIL PIER**
SCALE: N.T.S.

GRANITE PIER LOCATIONS			
STREET NAME	STATION	OFFSET	SIDE
Union Driveway	108+41	9'	LT
Union Driveway	108+85	9'	RT
Codjer Lane	115+90	11'	LT
Codjer Lane	116+24	10'	RT
Old Lancaster Road	142+76	11'	LT*
Old Lancaster Road	143+15	11'	RT
Hudson Road	174+84	11'	LT
Hudson Road	175+55	11'	RT
Morse Road	215+63	11'	LT
Morse Road	215+94	11'	RT
Haynes Road	274+90	11'	LT
Haynes Road	275+20	11'	RT
Pantry Road	284+34	7'	LT
Pantry Road	284+66	7'	RT
North Road	307+40	9'	LT
North Road	307+84	11'	RT

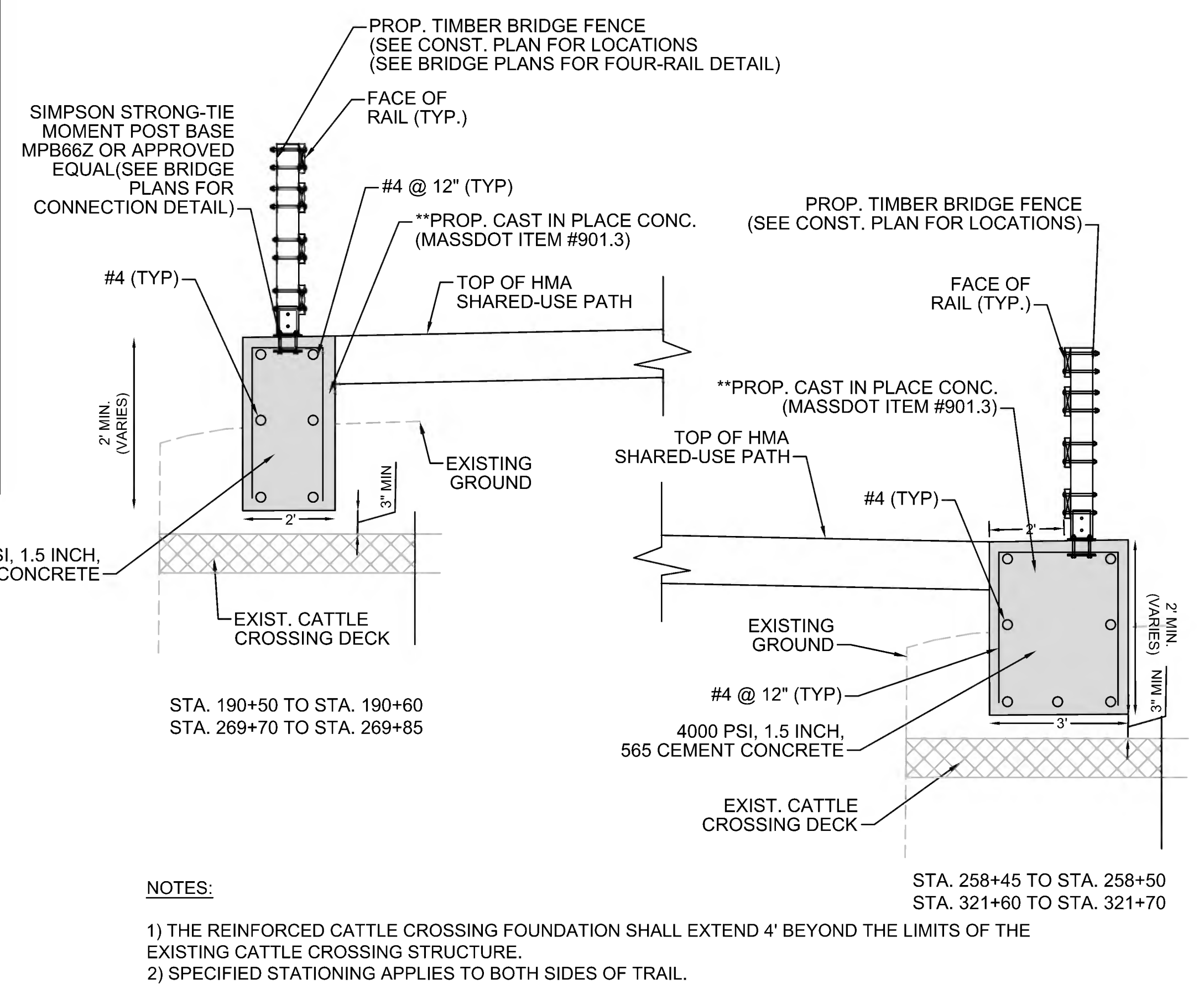

23 **REINFORCED TIMBER CONNECTION AT CATTLE CROSSING**
SCALE: N.T.S.

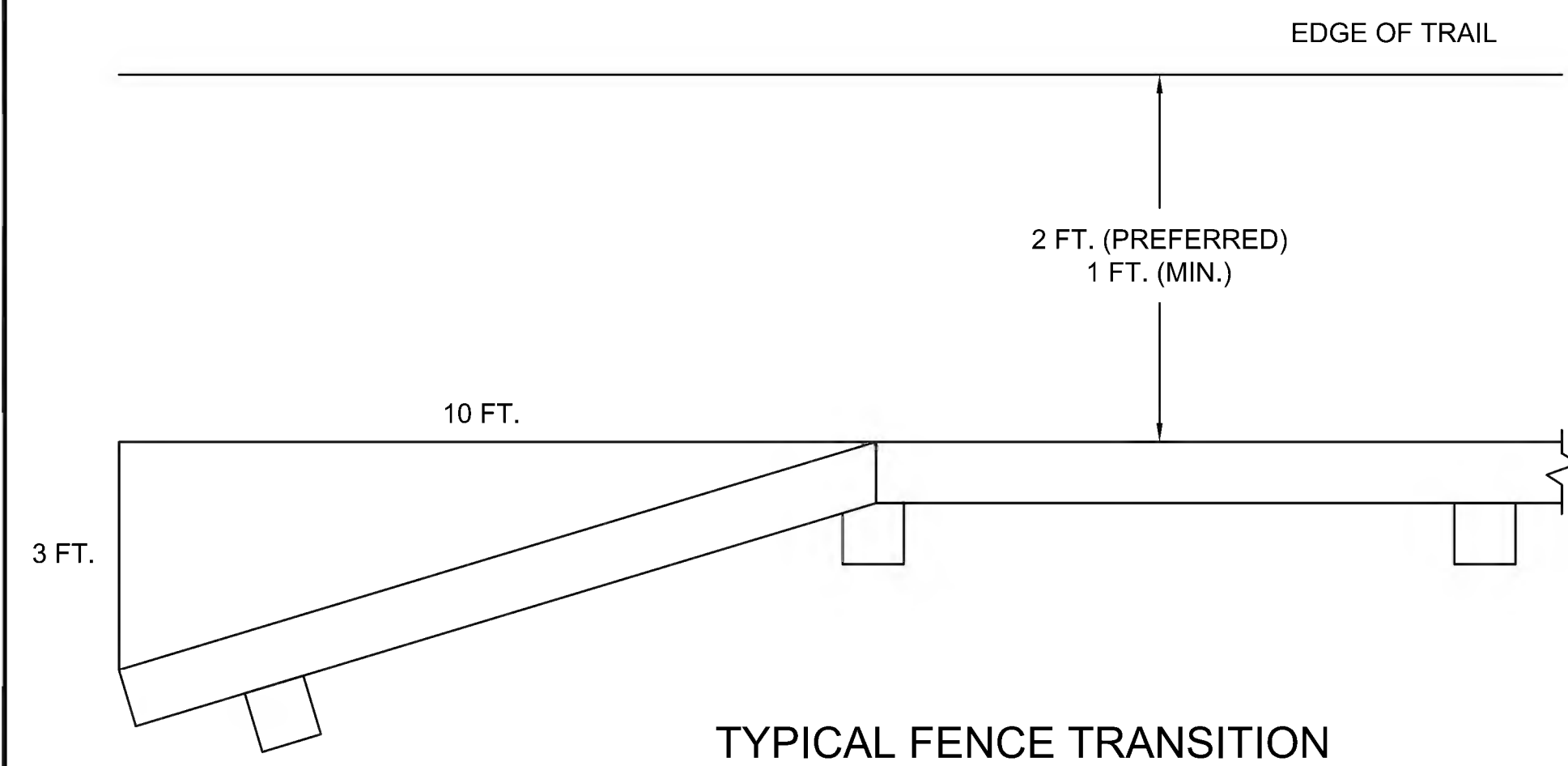

**TYPICAL FENCE TRANSITION
AT FENCE APPROACHES**
N.T.S.

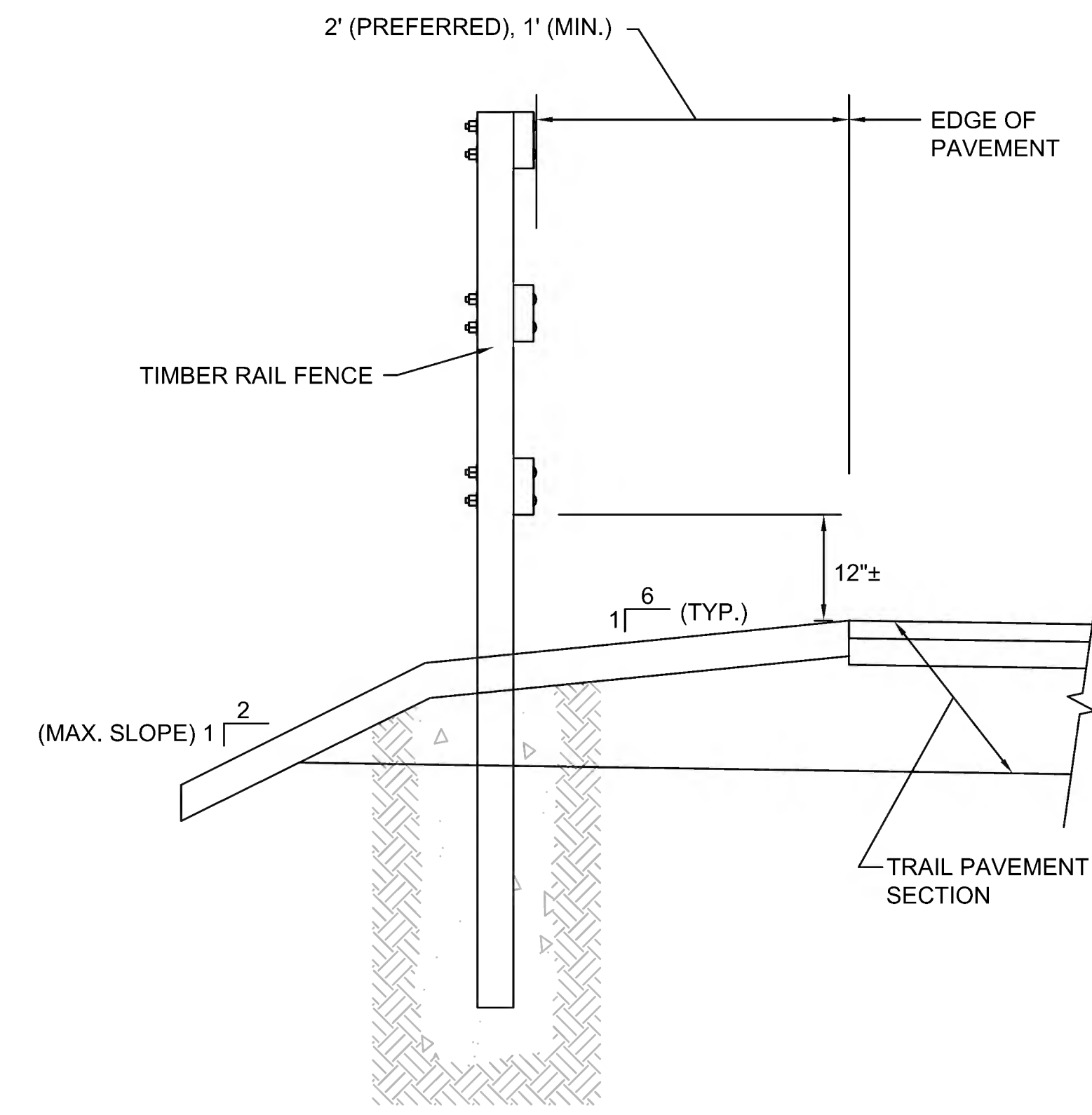

SUGGESTED TIMBER RAIL FENCE CONSTRUCTION SEQUENCE

1. AUGER OR DIG POST HOLE TO REQUIRED DIMENSIONS.
2. IF GROUND IS SATURATED, USE TUBE STEEL SLEEVE. SEE DETAIL ON THIS SHEET.
3. BACKFILL BOTTOM 6"± OF HOLE WITH GRAVEL AND COMPACT THOROUGHLY.
4. SET POST AND HOLD PLUMB DURING BACKFILLING.
5. BACKFILL WITH GRAVEL IN 12" LIFTS. COMPACT EACH LIFT THOROUGHLY.
6. CLAMP RAILS TO POSTS AND FIELD DRILL BOLT HOLES.
7. SET BOLTS, WASHERS AND NUTS.

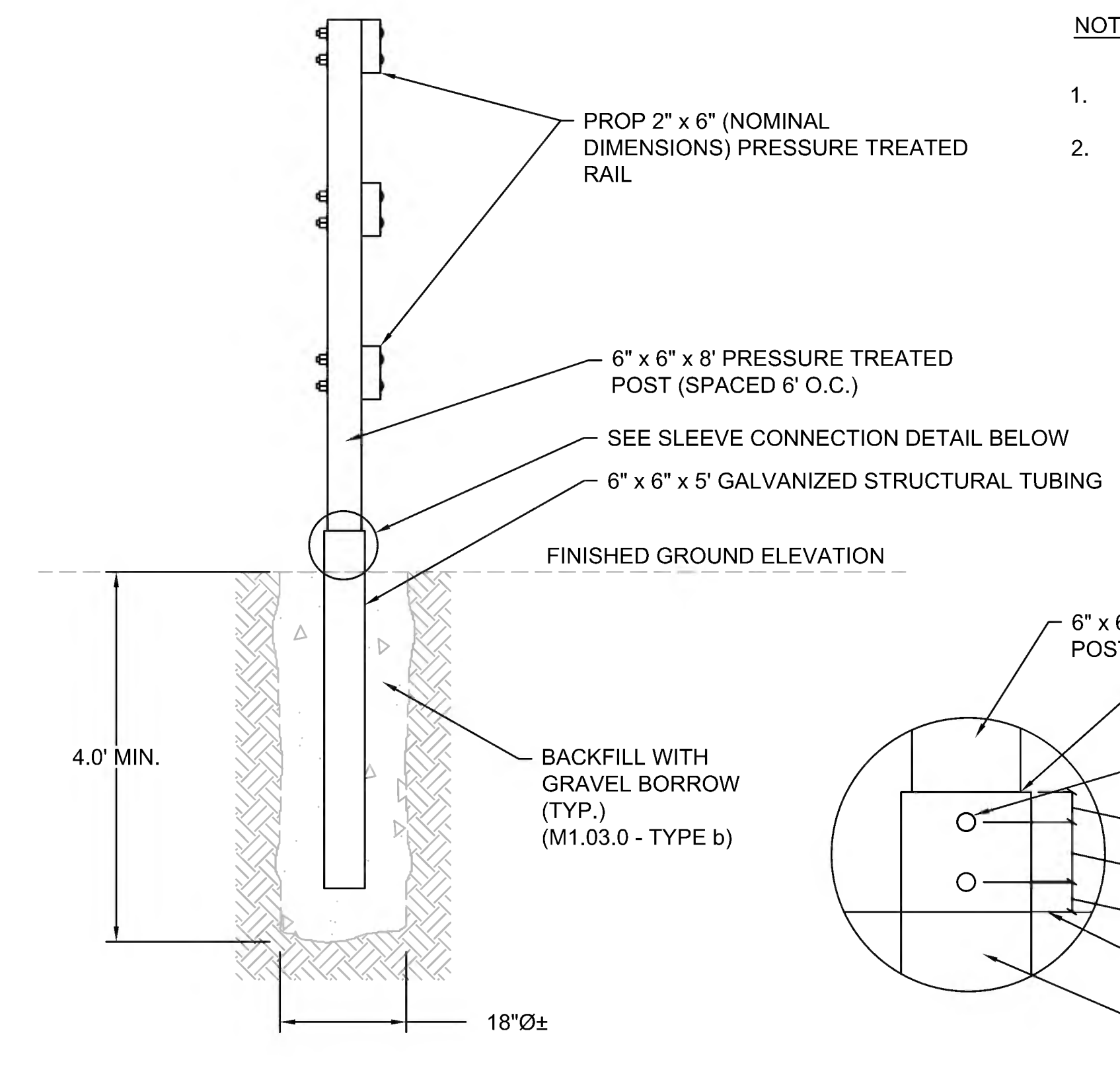

**TIMBER FENCE TUBE STEEL SLEEVE
(FOR USE IN SATURATED LOCATIONS)**
N.T.S.

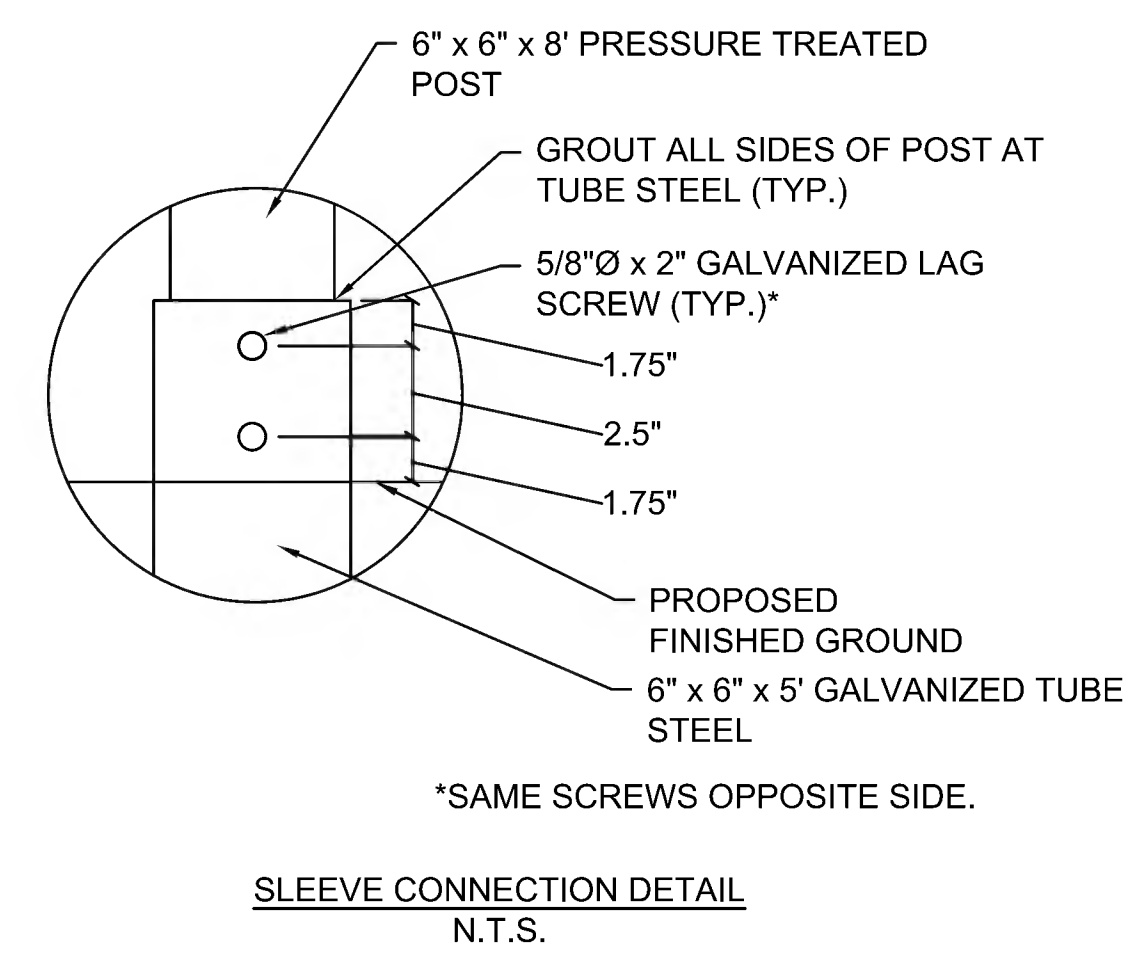

- NOTES:**
1. TIMBER PRESERVATIVES SHALL BE USED ON ALL WOOD TIMBER.
 2. ALL CUT ENDS SHALL BE PAINTED WITH PRESERVATIVE IN THE FIELD PER MANUFACTURERS DIRECTION.

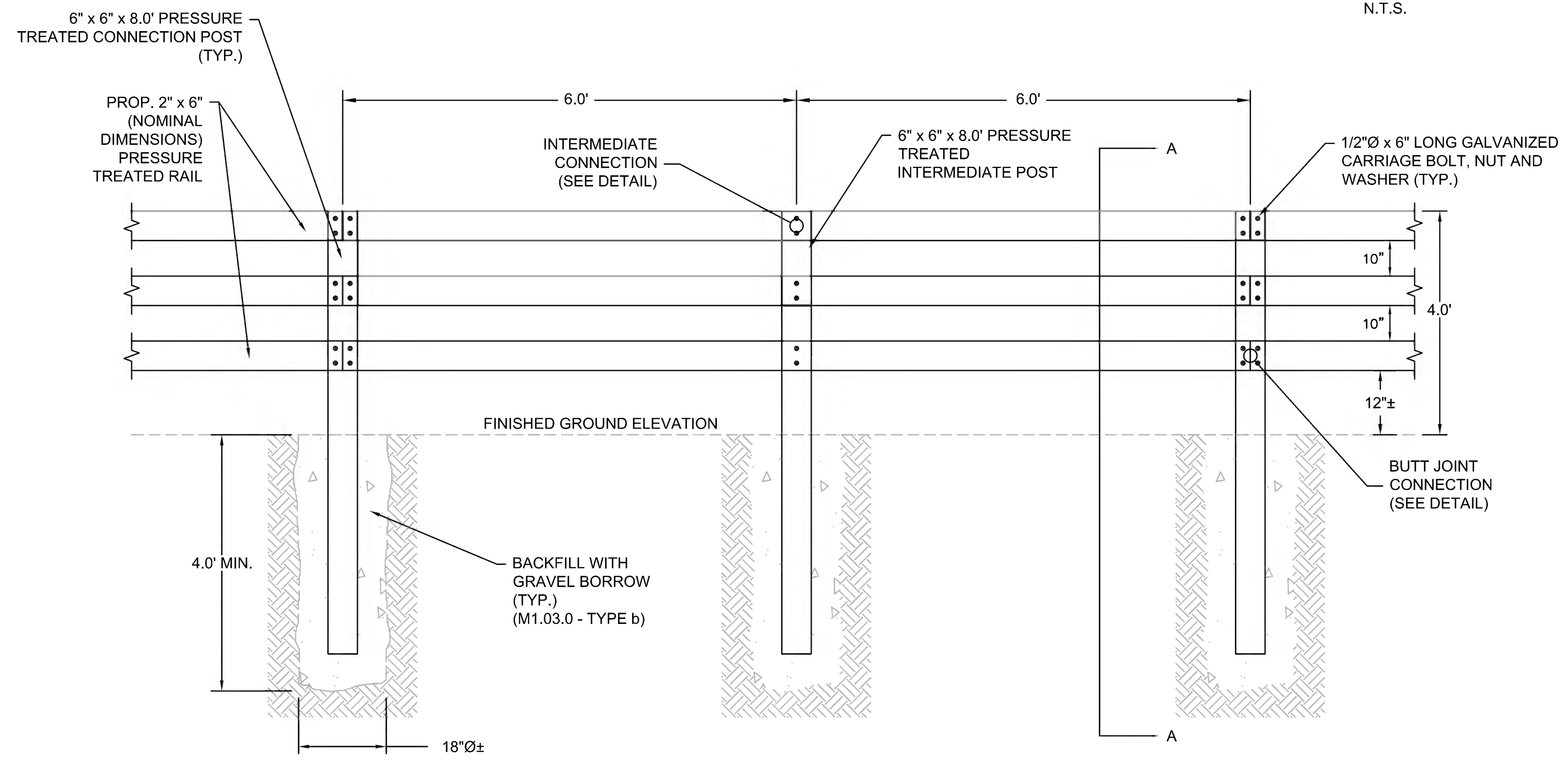
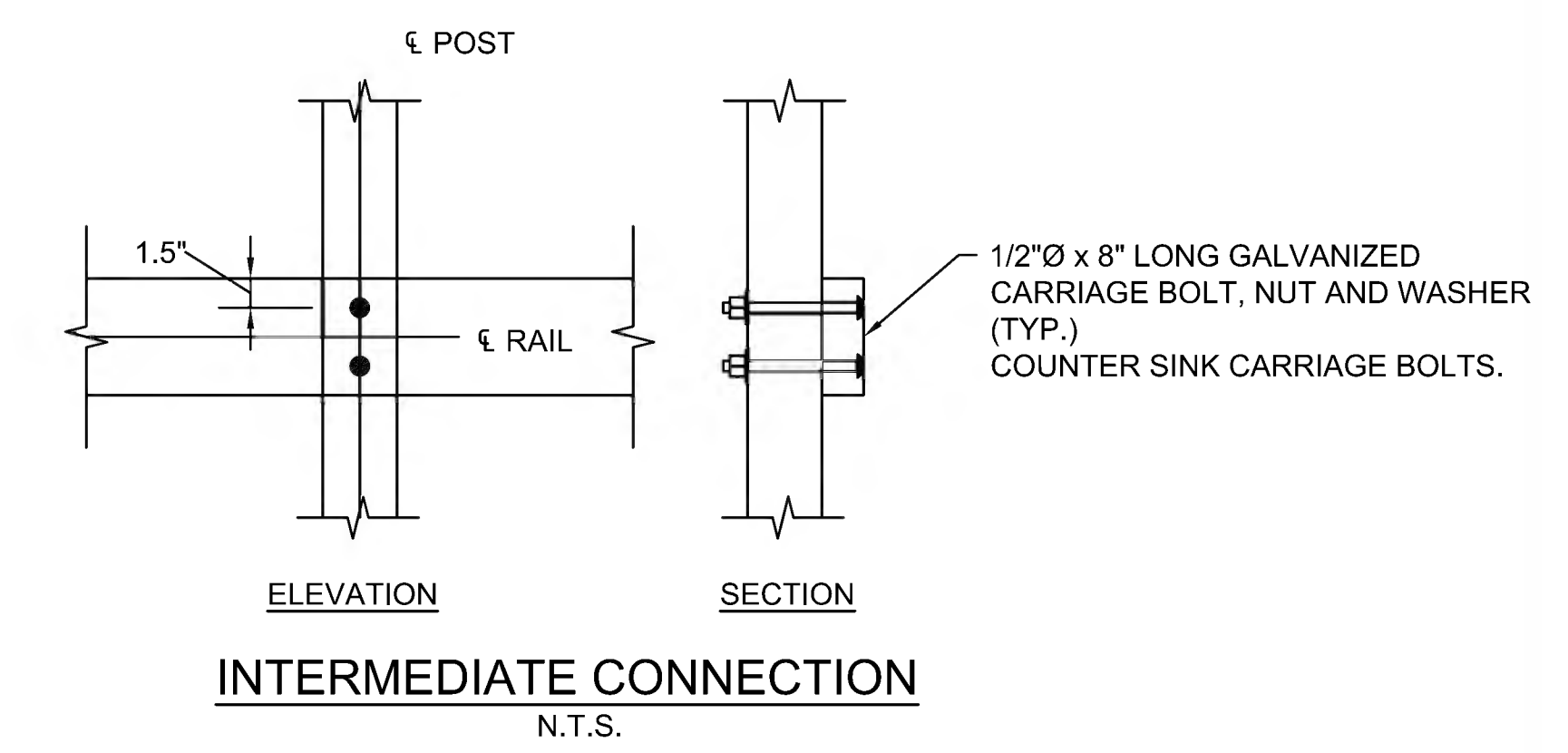
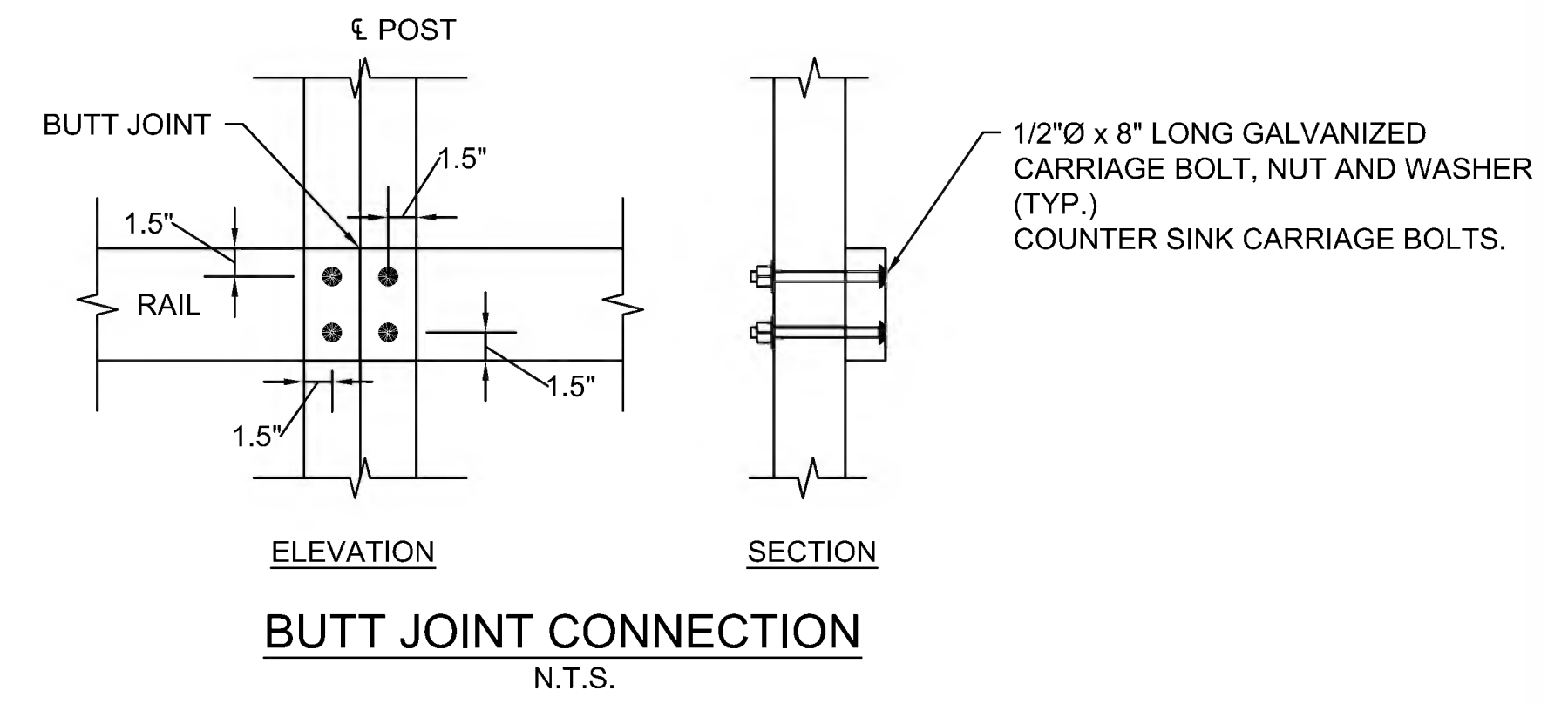

- NOTES:**
1. FOR RADII LESS THAN 165', USE CONNECTION POSTS SET AT 6.0' O.C. AND SHORTEN RAILS ACCORDINGLY.

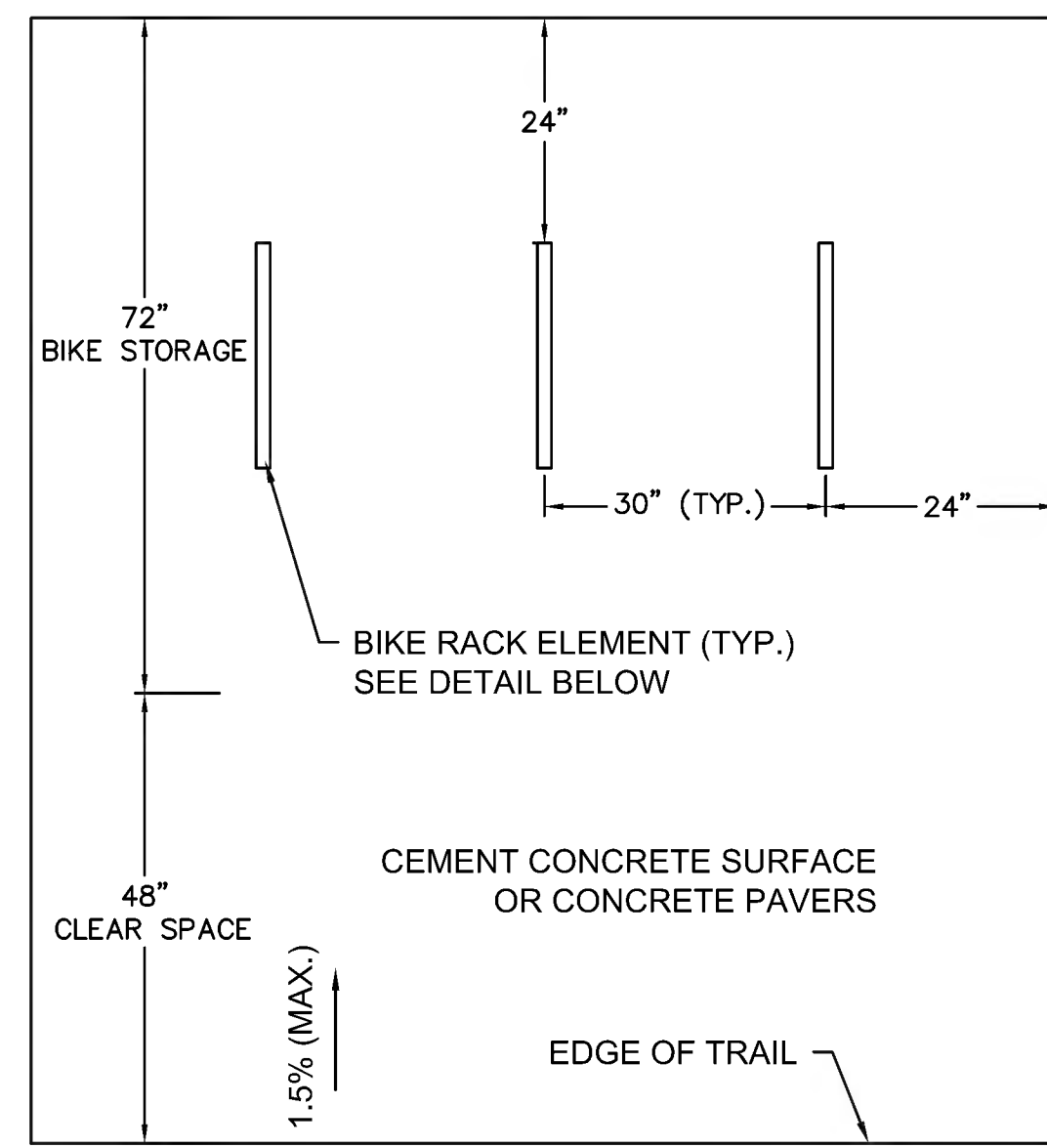

NOTES:
• SEE PLANS FOR QUANTITY OF BIKE RACK ELEMENTS

BICYCLE RACK PLACEMENT

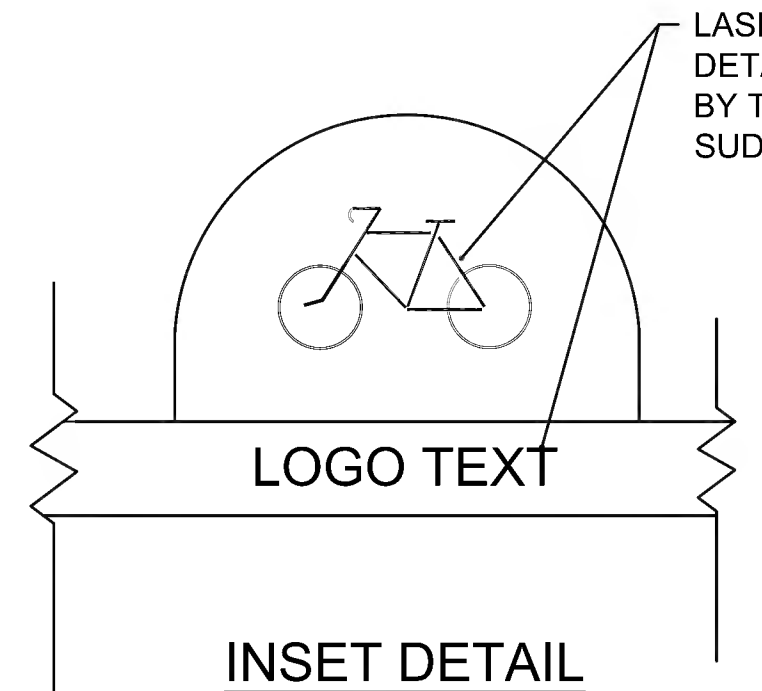

NOTES:
1. EACH BIKE RACK SHALL INCLUDE A LASER-CUT LOGO. LOGO DETAIL TO BE PROVIDED BY THE TOWN OF SUDBURY.
2. DIMENSIONS ARE APPROXIMATE AND WILL BE DETERMINED IN COORDINATION WITH THE MANUFACTURER. BIKE RACK ELEMENTS TO BE OF THE INVERTED "U".
3. EACH BIKE RACK SHALL ACCOMMODATE TWO BICYCLES.
4. ALL POSTS AND HARDWARE SHALL BE FACTORY COATED FEDERAL GREEN (SEE SPECIAL PROVISIONS)

27 BICYCLE RACK
SCALE: N.T.S.

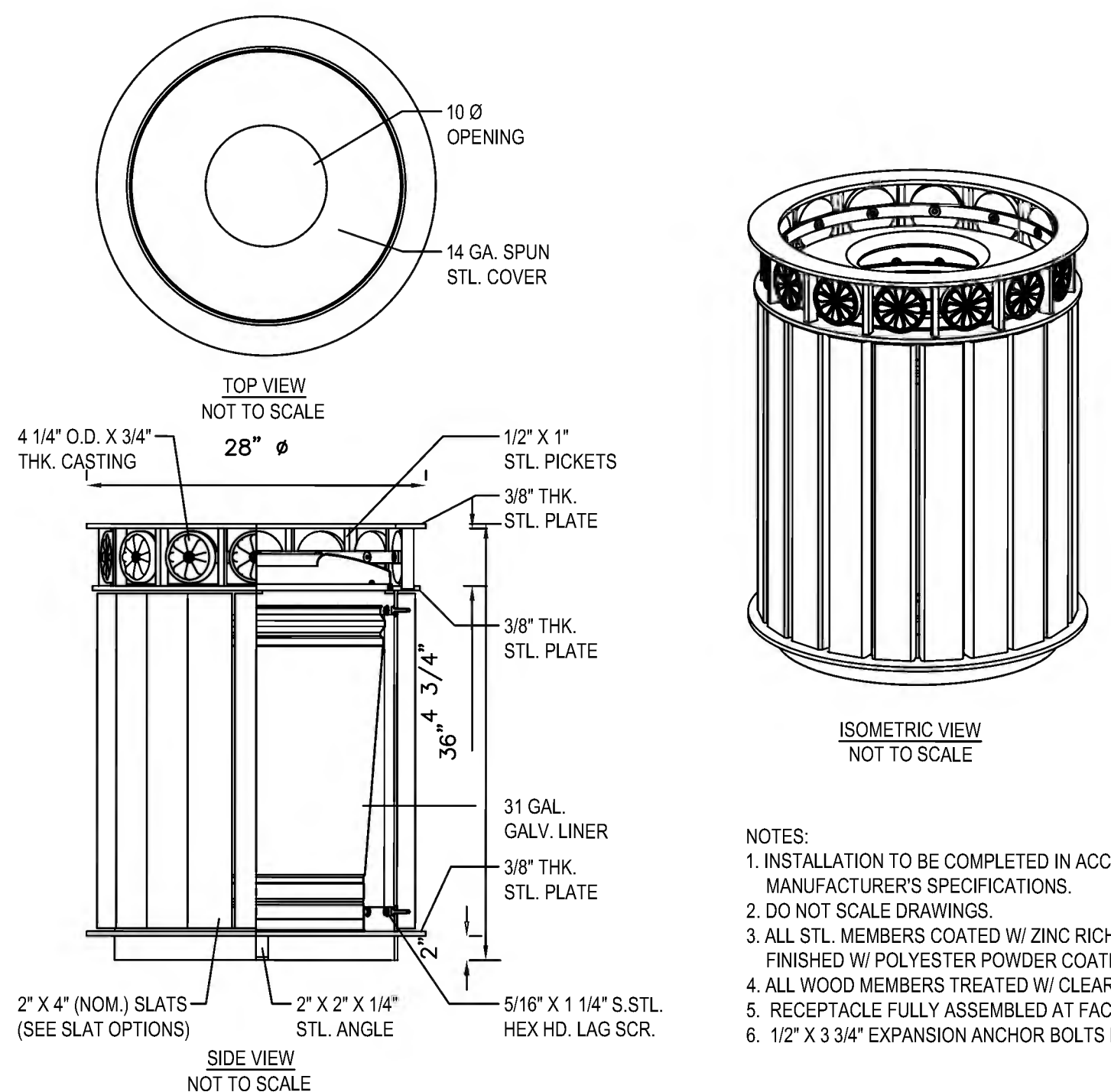

NOTES:
1. INSTALLATION TO BE COMPLETED IN ACCORDANCE WITH MANUFACTURER'S SPECIFICATIONS.
2. DO NOT SCALE DRAWINGS.
3. ALL STL. MEMBERS COATED W/ ZINC RICH EPOXY THEN FINISHED W/ POLYESTER POWDER COATING.
4. ALL WOOD MEMBERS TREATED W/ CLEAR PRESERVATIVE.
5. RECEPTACLE FULLY ASSEMBLED AT FACTORY.
6. 1/2" X 3/4" EXPANSION ANCHOR BOLTS PROVIDED.

25 TRASH RECEPTACLE
SCALE: N.T.S.

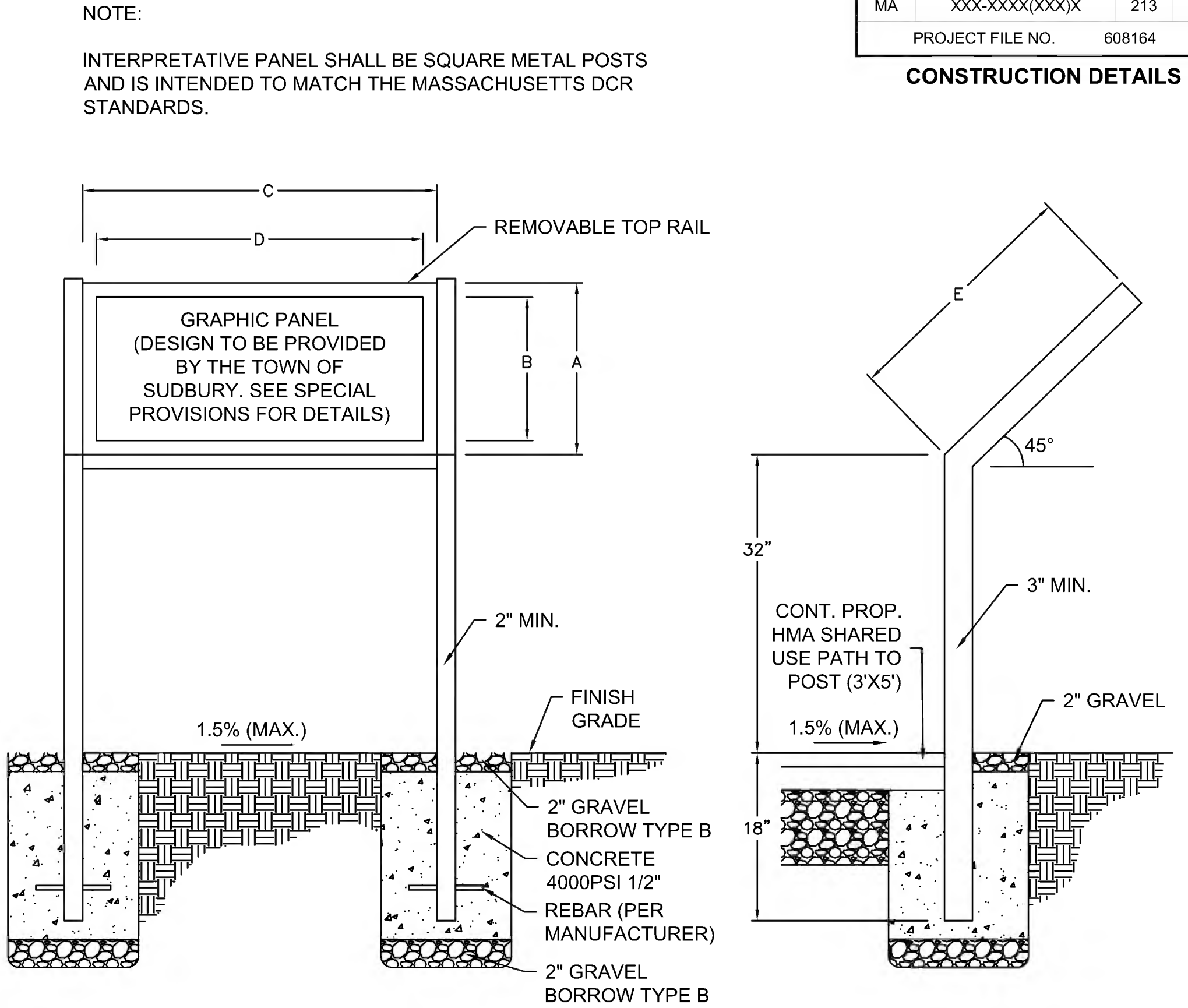

SIGN TYPE	DIMENSION TABLE				
	HEIGHT	WIDTH		DEPTH	
	A	B	C	D	E
26" x 38"	26"	23"	38"	35"	26.5"

26 INTERPRETIVE SIGN
SCALE: N.T.S.

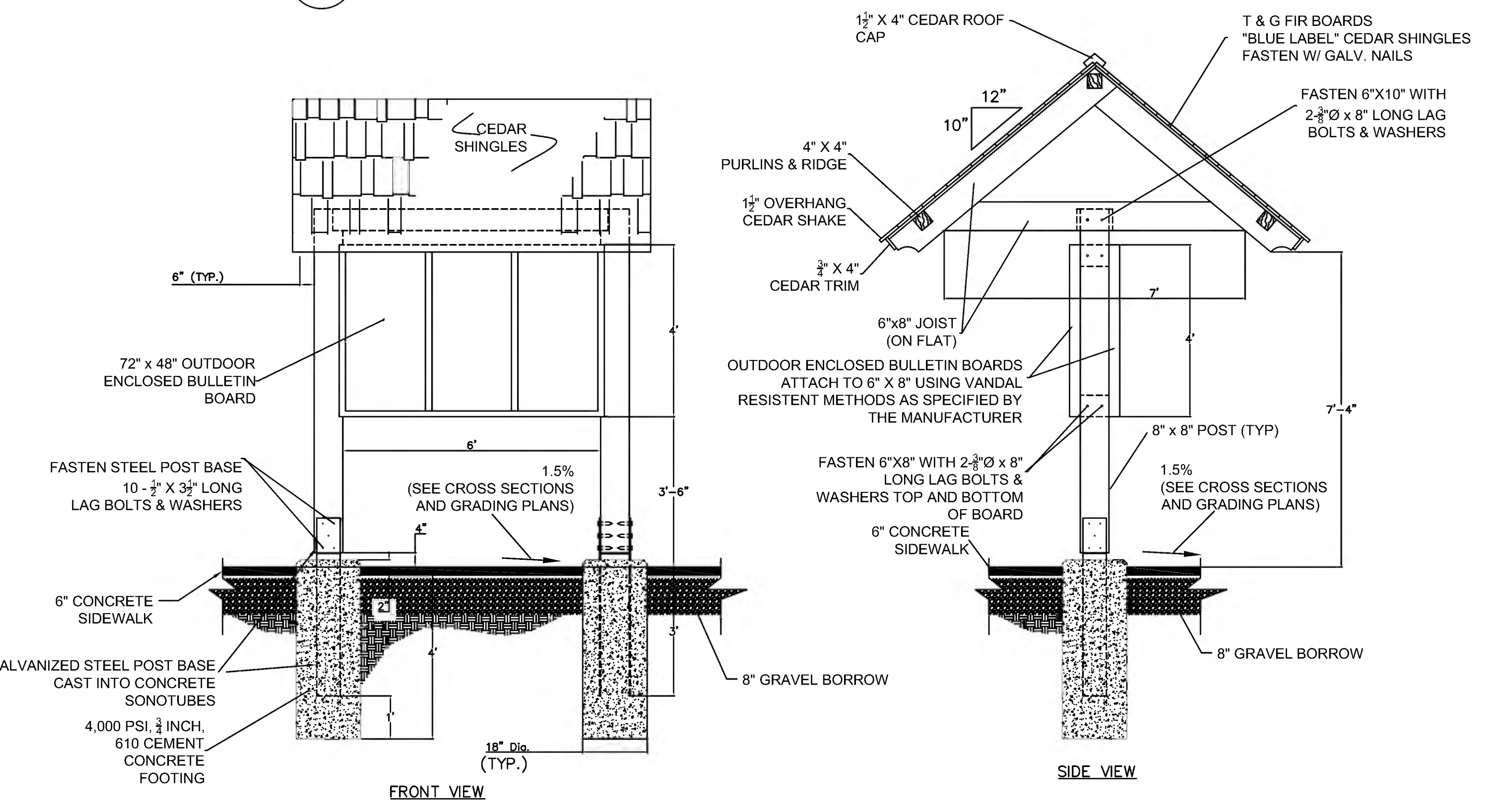
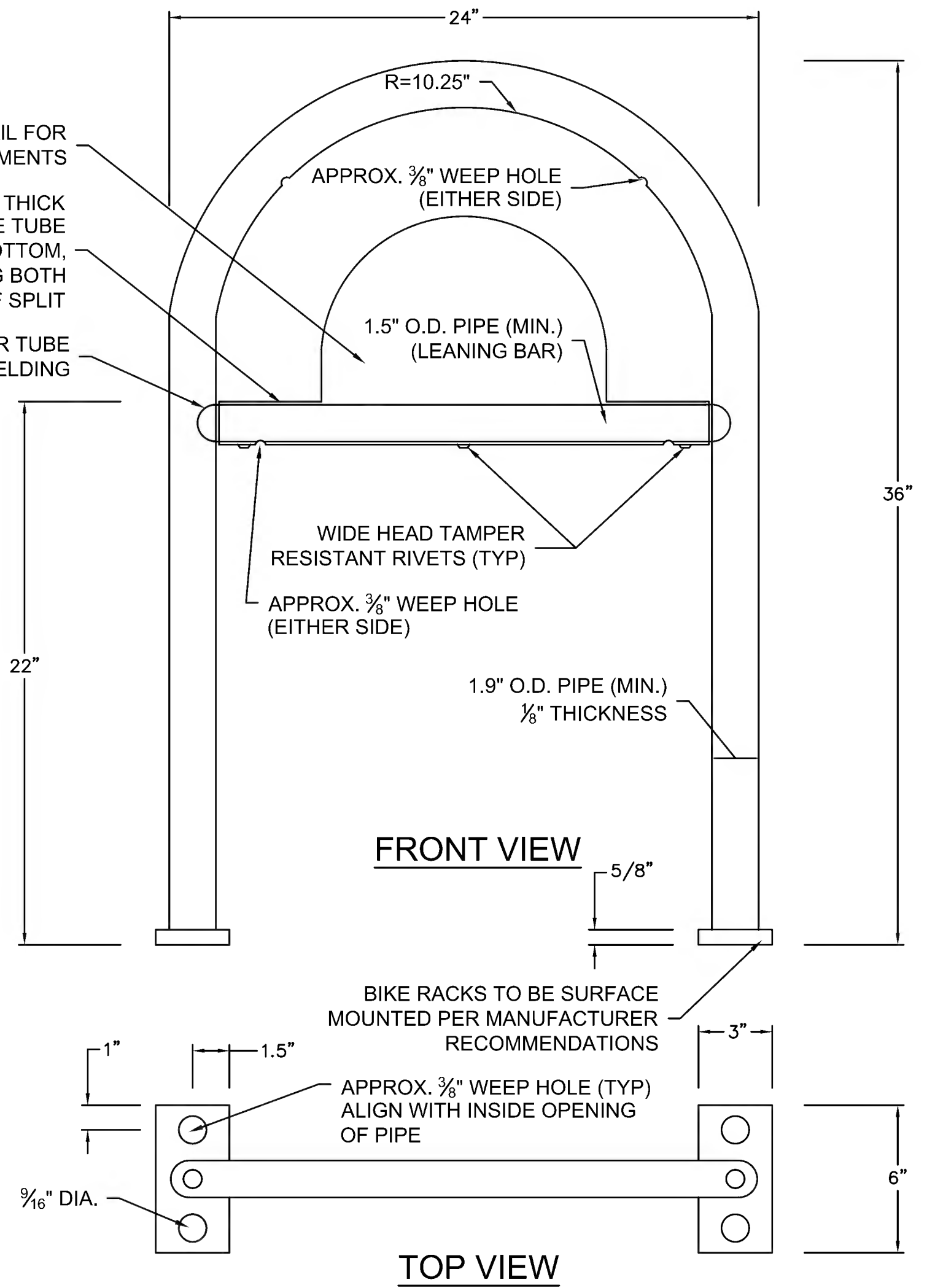

28 DISPLAY BOARD
SCALE: N.T.S.

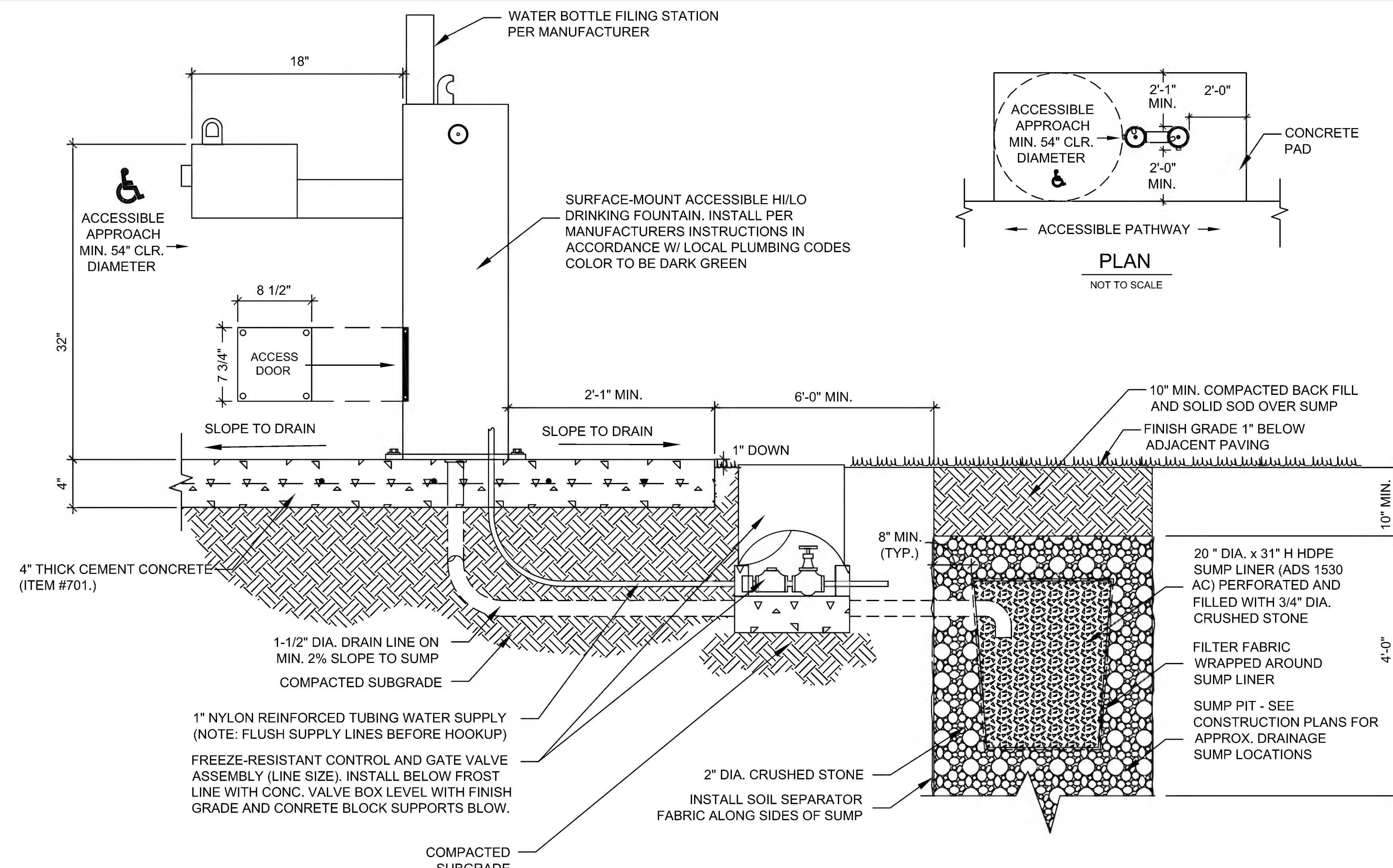

- GENERAL NOTES:**
1. DRINKING FOUNTAIN MUST BE INSTALLED ADJACENT TO AN ACCESSIBLE ROUTE.
 2. SPECIFIED DRINKING FOUNTAIN TO BE IN ACCORDANCE W/ MAAB ACCESSIBILITY STANDARDS.
 3. BASED ON PROJECT SPECIFICATIONS, MODEL MAY INCLUDE DOG BOWL AND/OR JUG FILLER. REFERENCE MANUFACTURER'S PRODUCT CATALOG FOR ACCESSORY ITEMS.

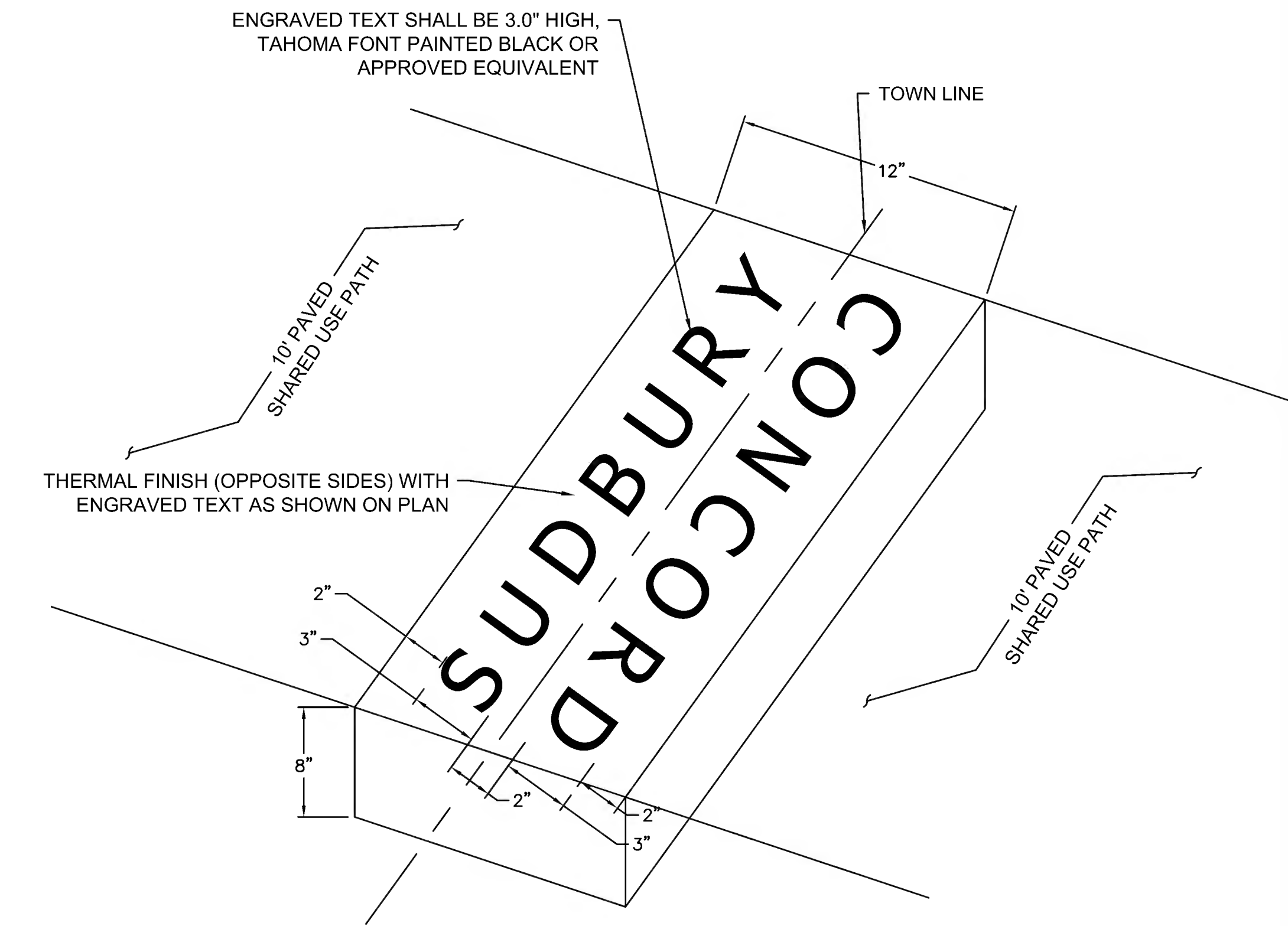

30 GRANITE TOWN LINE MARKER
SCALE: N.T.S.

29 HYDRATION STATION
SCALE: N.T.S.

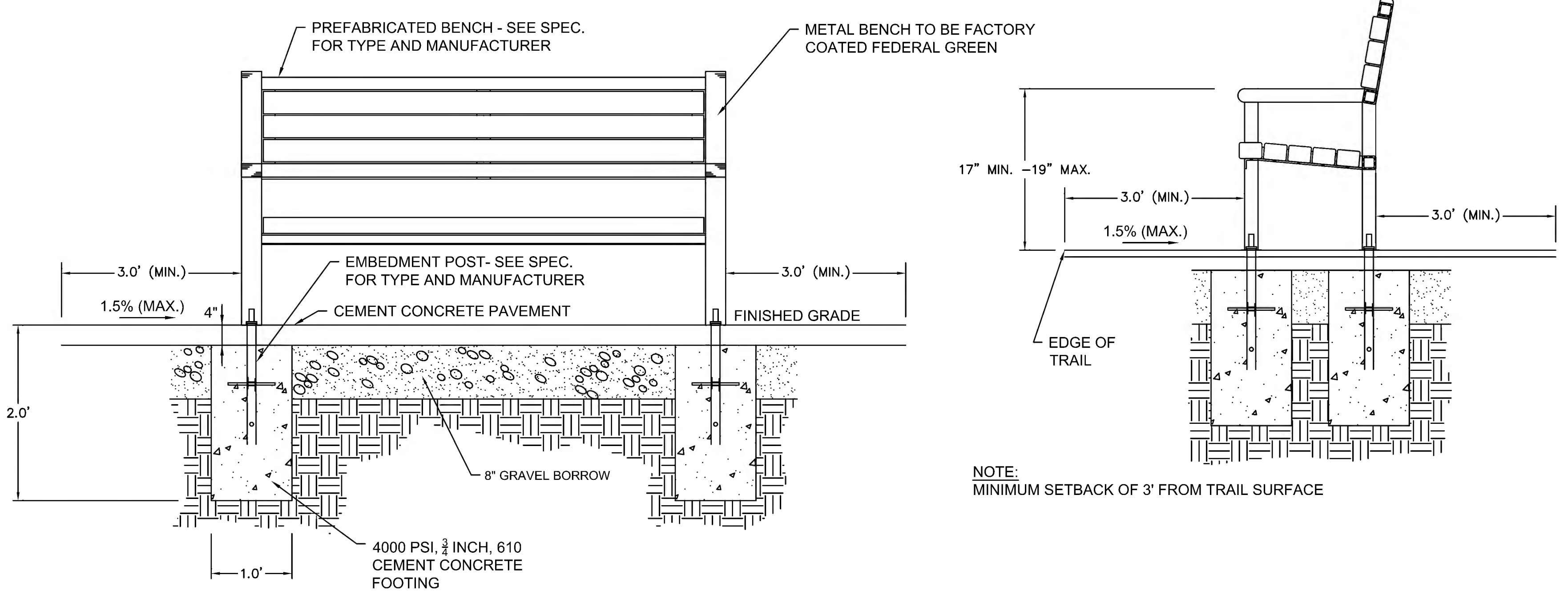

31 BENCH
SCALE: N.T.S.

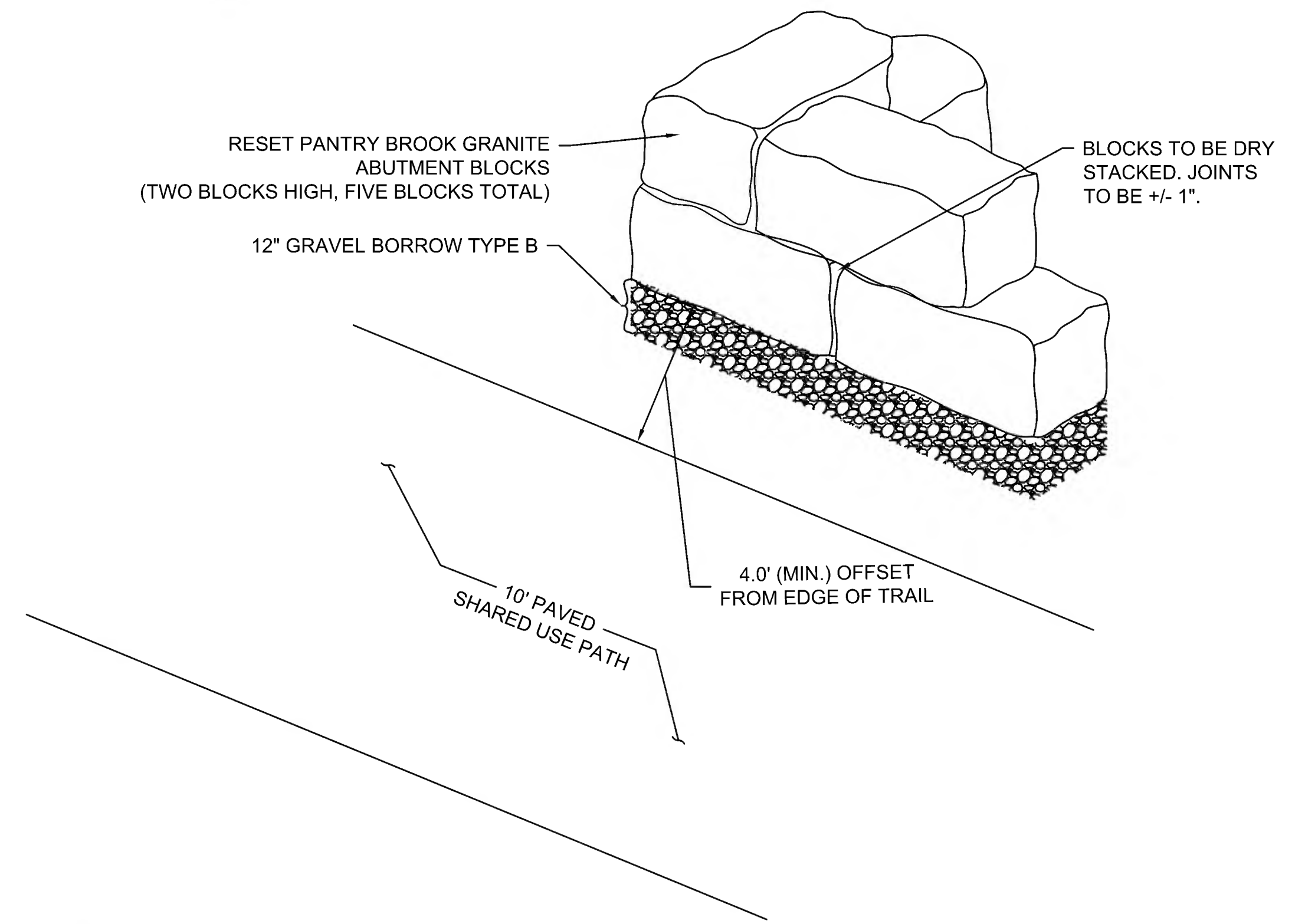

32 PANTRY BROOK ABUTMENT BLOCKS RESET STA. 260+89
SCALE: N.T.S.

NOTE:
THESE PLAN VIEW AND ELEVATION DRAWINGS ARE A PRELIMINARY ARCHITECTURAL REPRESENTATION OF THE BUILDING.

LEGEND		
SYMBOL	DESCRIPTION	AREA / QUANTITY
—	GABLE WINDOW	6
—	16" x 24" EXTERIOR WALL VENT LOCATED IN CMU WALL	2
—	EXTERIOR WALL LIGHTS	3
—	INTERIOR CEILING LIGHTS	3

WALL TYPE SCHEDULE

8" MORTAR JOINT CMU WALL REINFORCED & GROUT FILLED

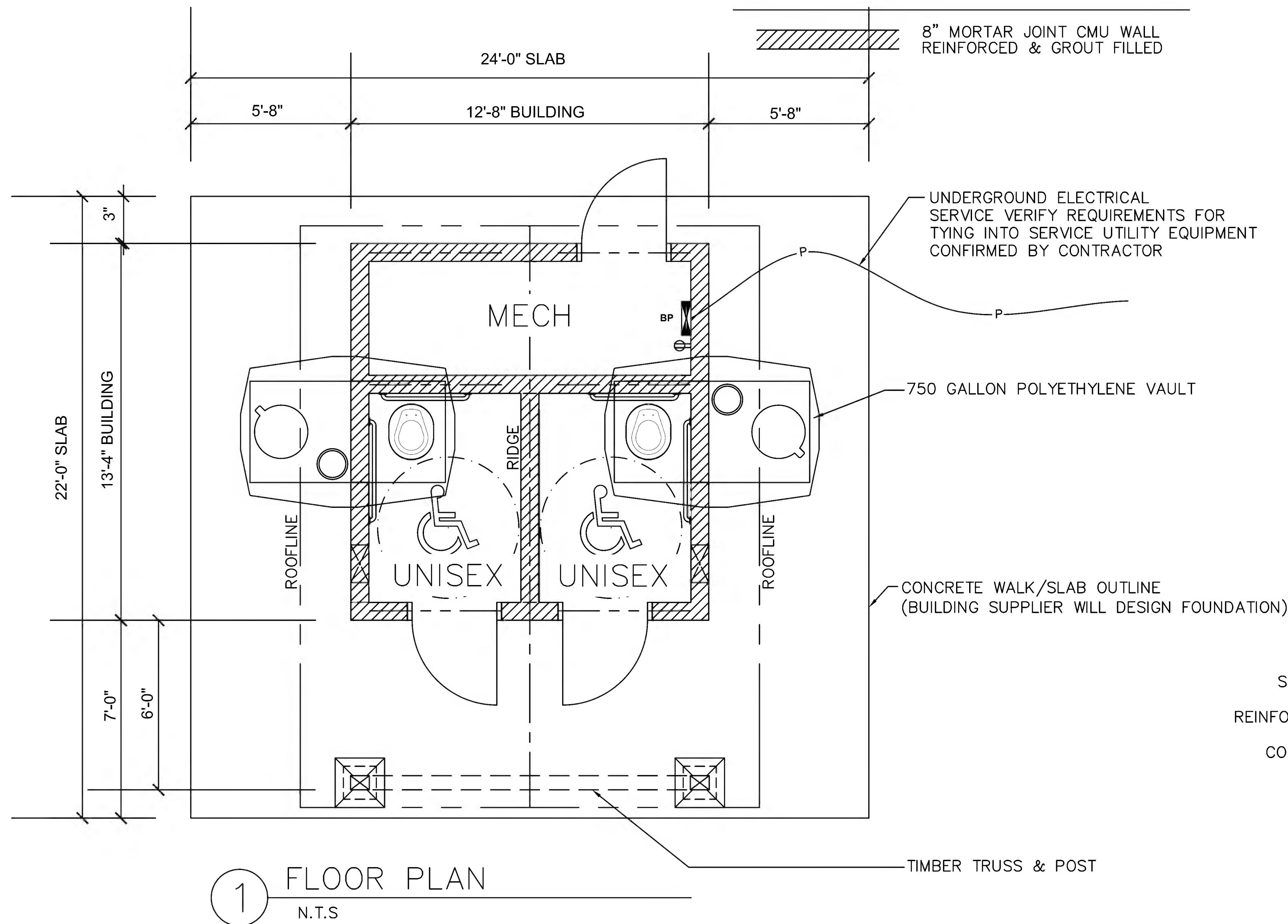

① FLOOR PLAN
N.T.S.

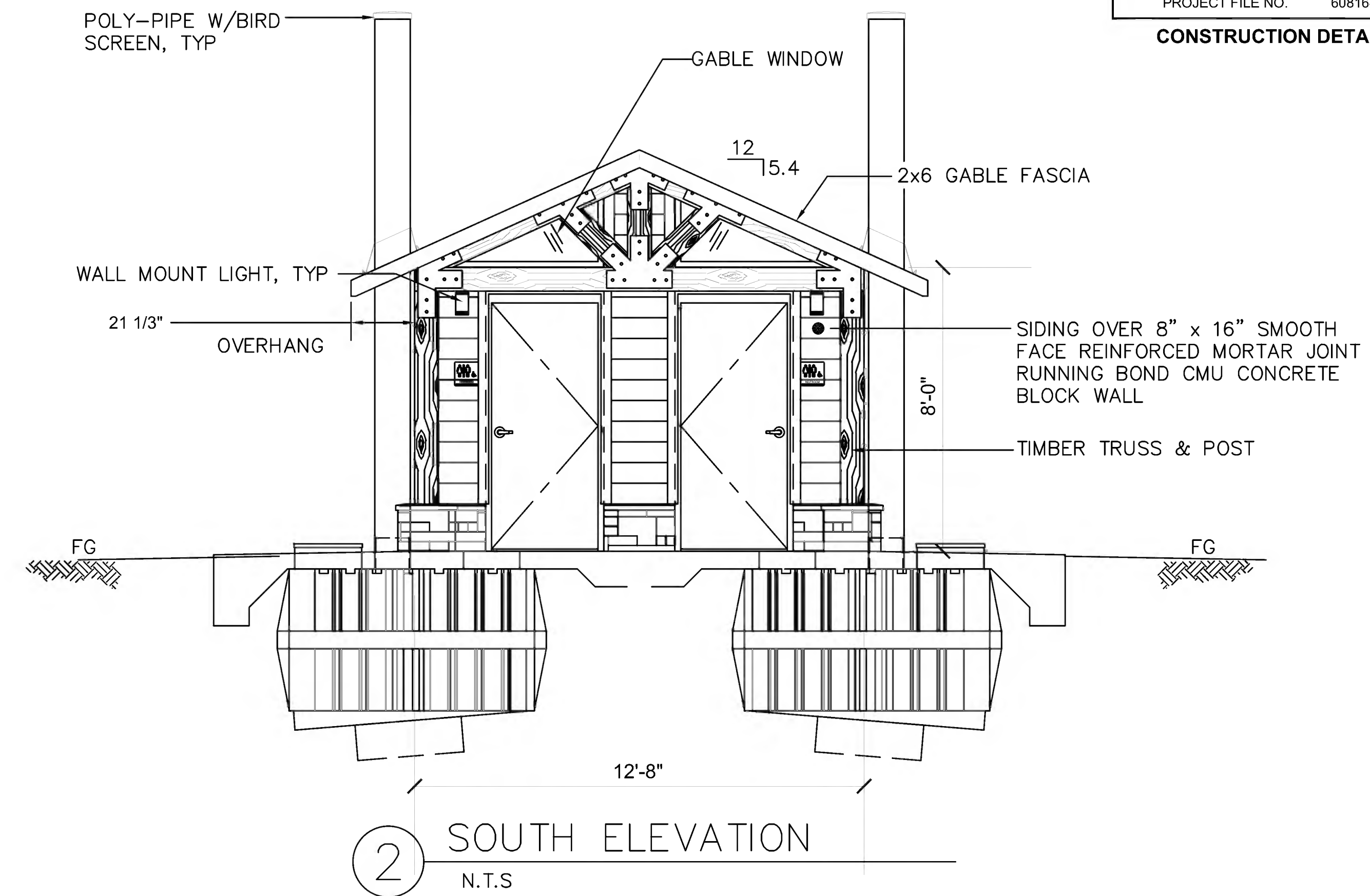

② SOUTH ELEVATION
N.T.S.

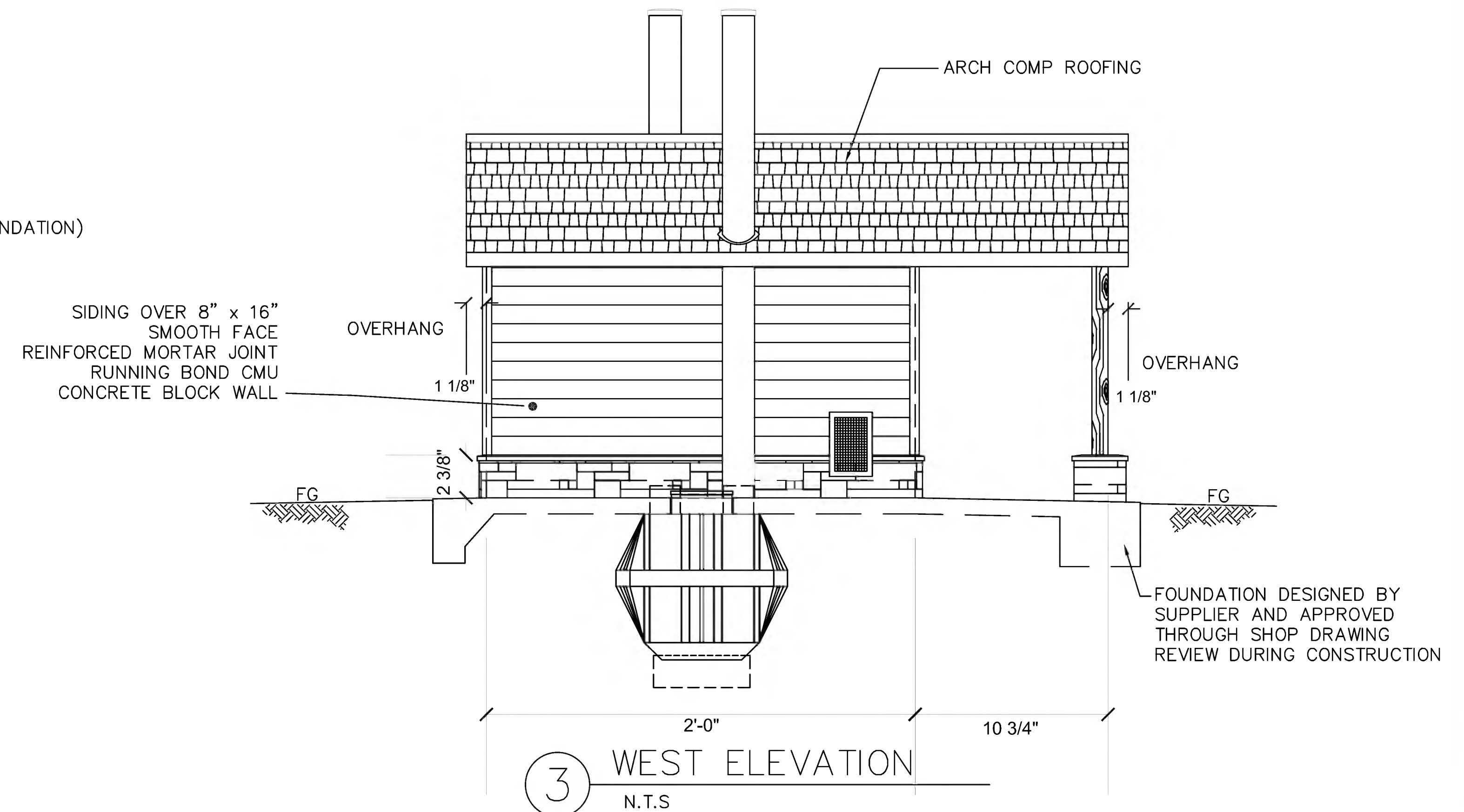

③ WEST ELEVATION
N.T.S.

NOTE:
THESE PLAN VIEW AND ELEVATION DRAWINGS ARE A PRELIMINARY ARCHITECTURAL REPRESENTATION OF THE BUILDING. ALL DIMENSIONS, FEATURES AND COMPONENTS SHOWN ON THESE PRELIMINARY DRAWINGS SHALL BE APPROVED BY THE TOWN DURING CONSTRUCTION/SUBMISSION OF SHOP DRAWINGS.

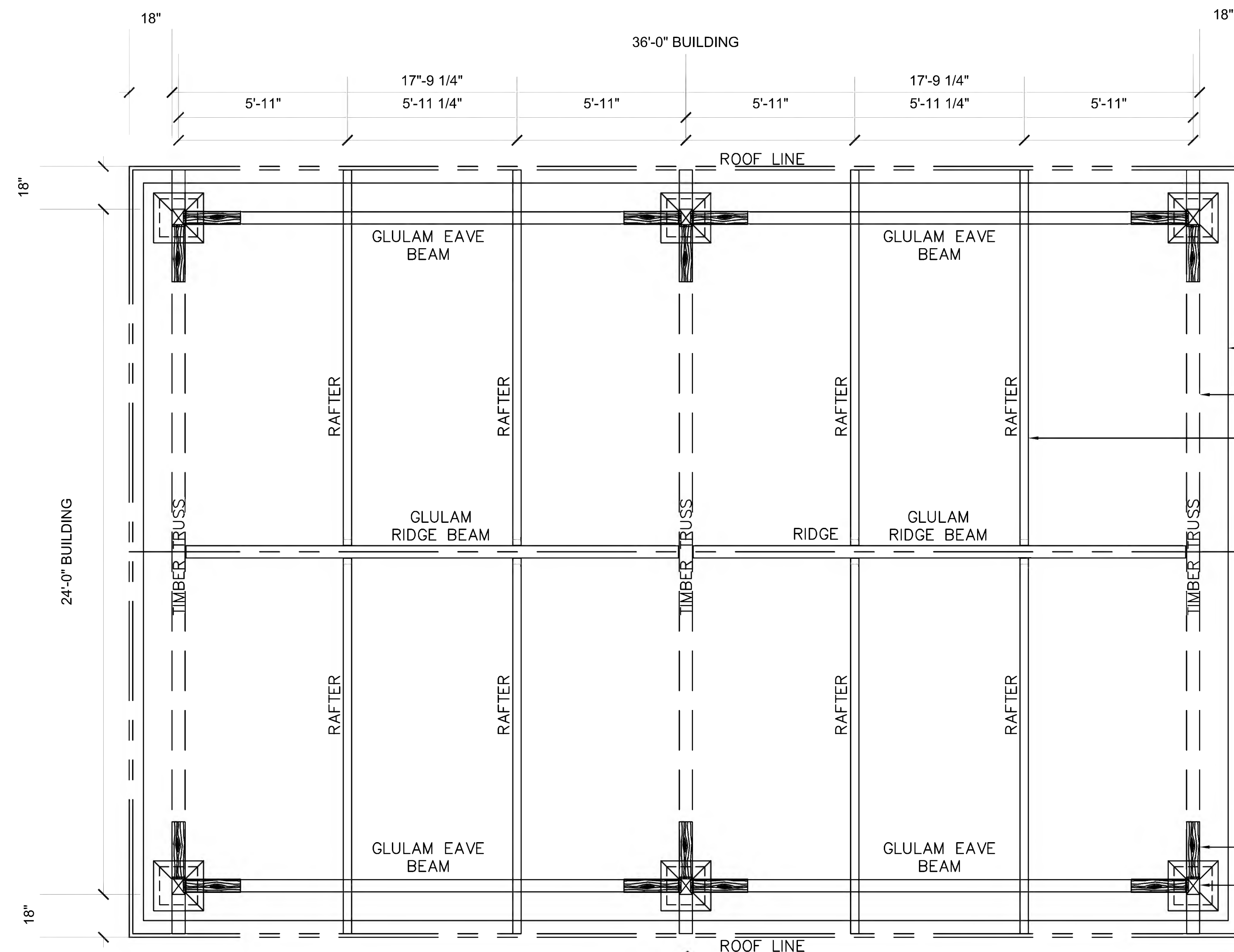

1 FLOOR PLAN
N.T.S.

LEGEND		
SYMBOL	DESCRIPTION	AREA/QUANTITY
	WOOD TRUSS	3
	GLU-LAM BEAMS	6

- CONCRETE BY INSTALLER
- TIMBER TRUSS, TYP (3)
- RAFTER, TYP (8)

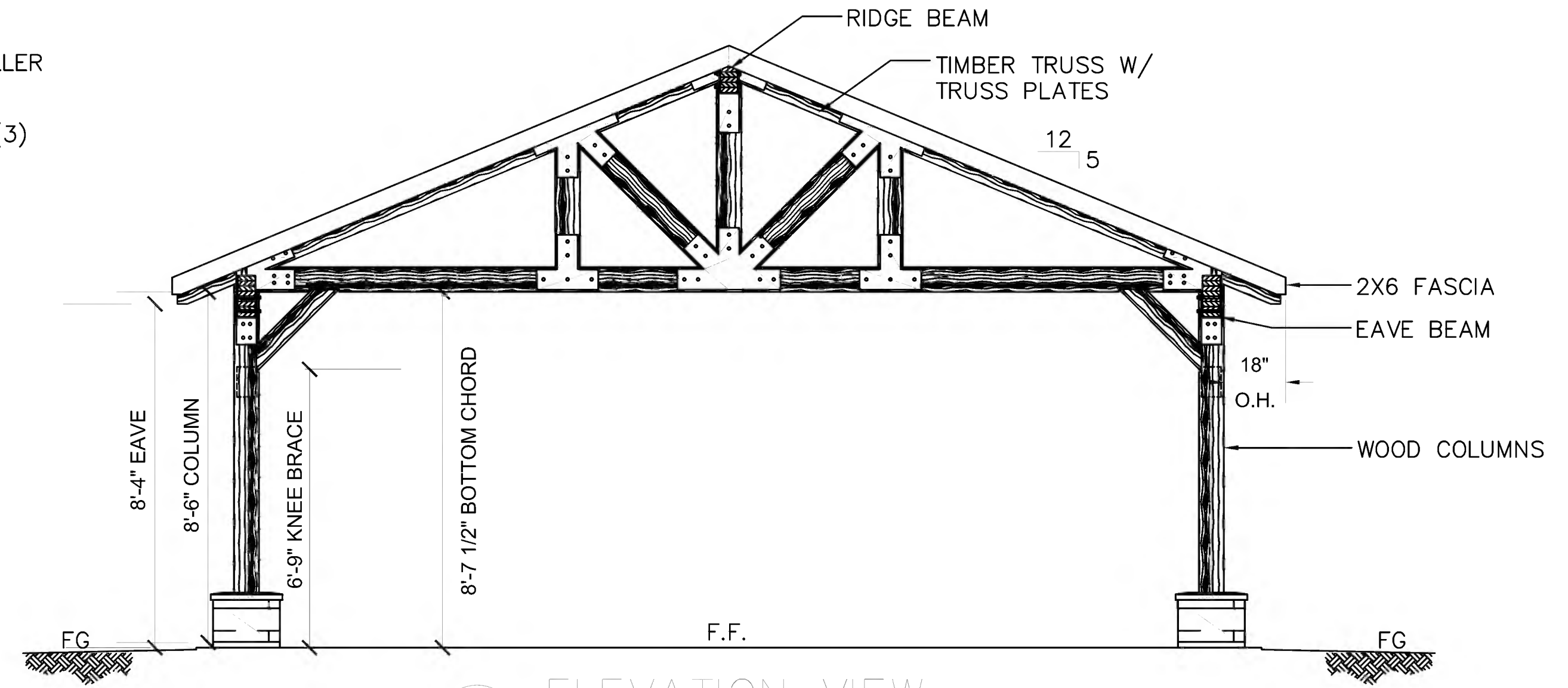

B ELEVATION VIEW
N.T.S.

- WOOD KNEE BRACES, TYP (14)
- WOOD COLUMNS, TYP (6)

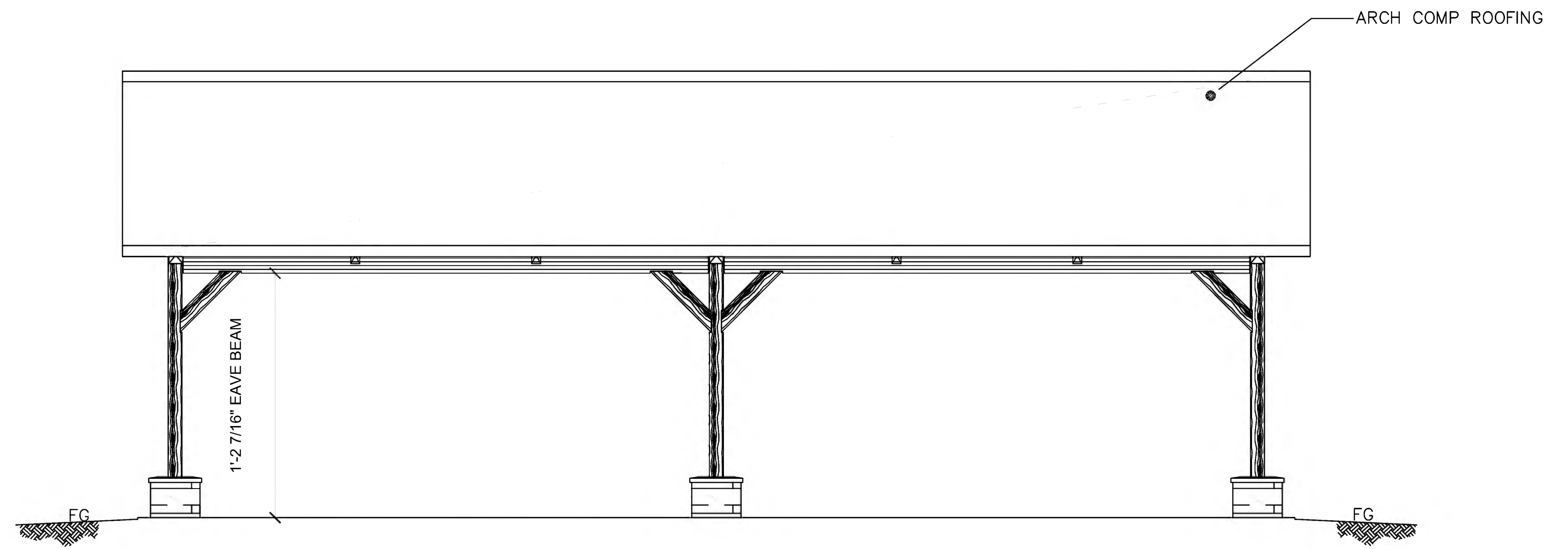

C ELEVATION VIEW
N.T.S.

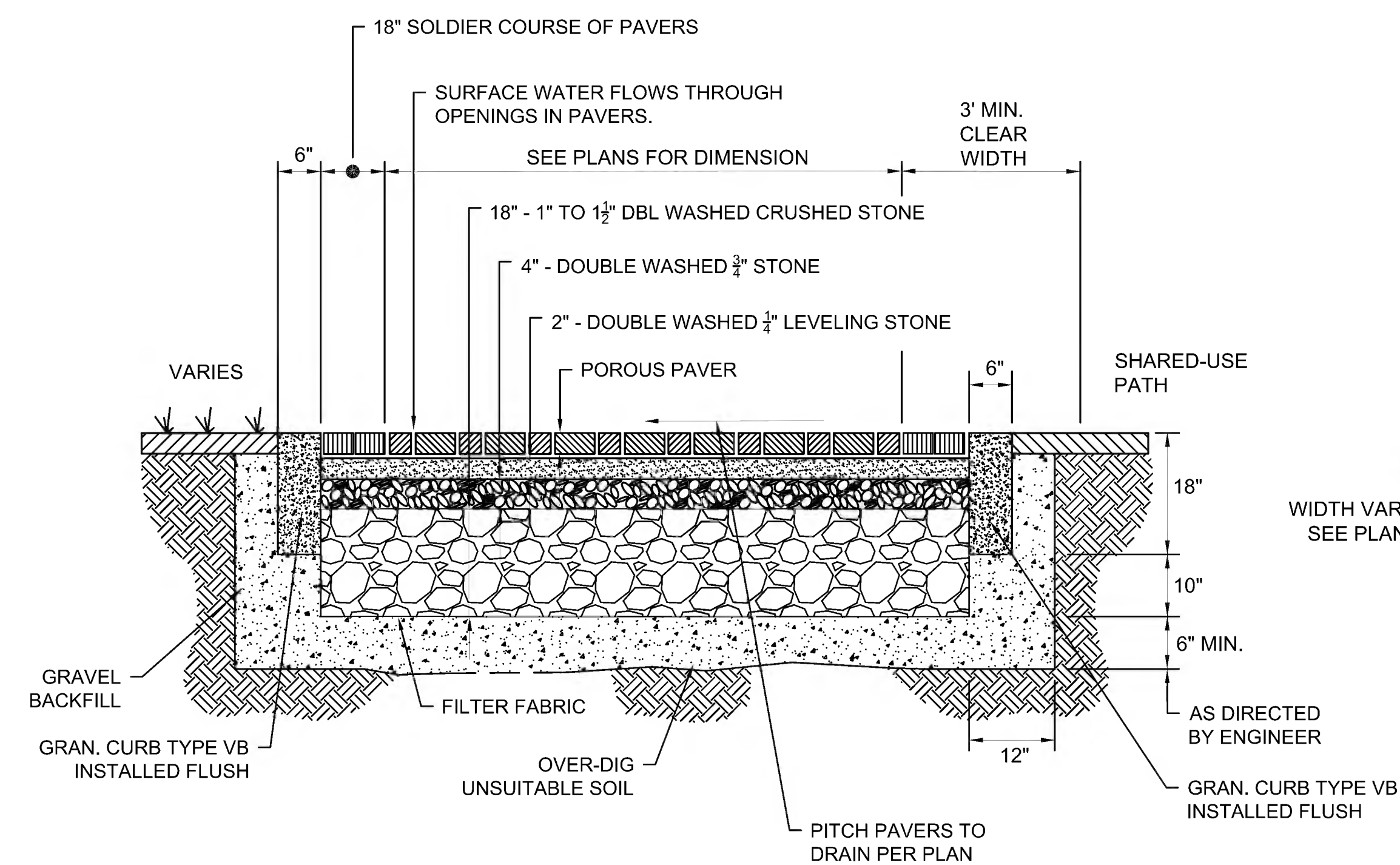

35 PERVIOUS PAVER TYPICAL SECTION
SCALE: N.T.S.

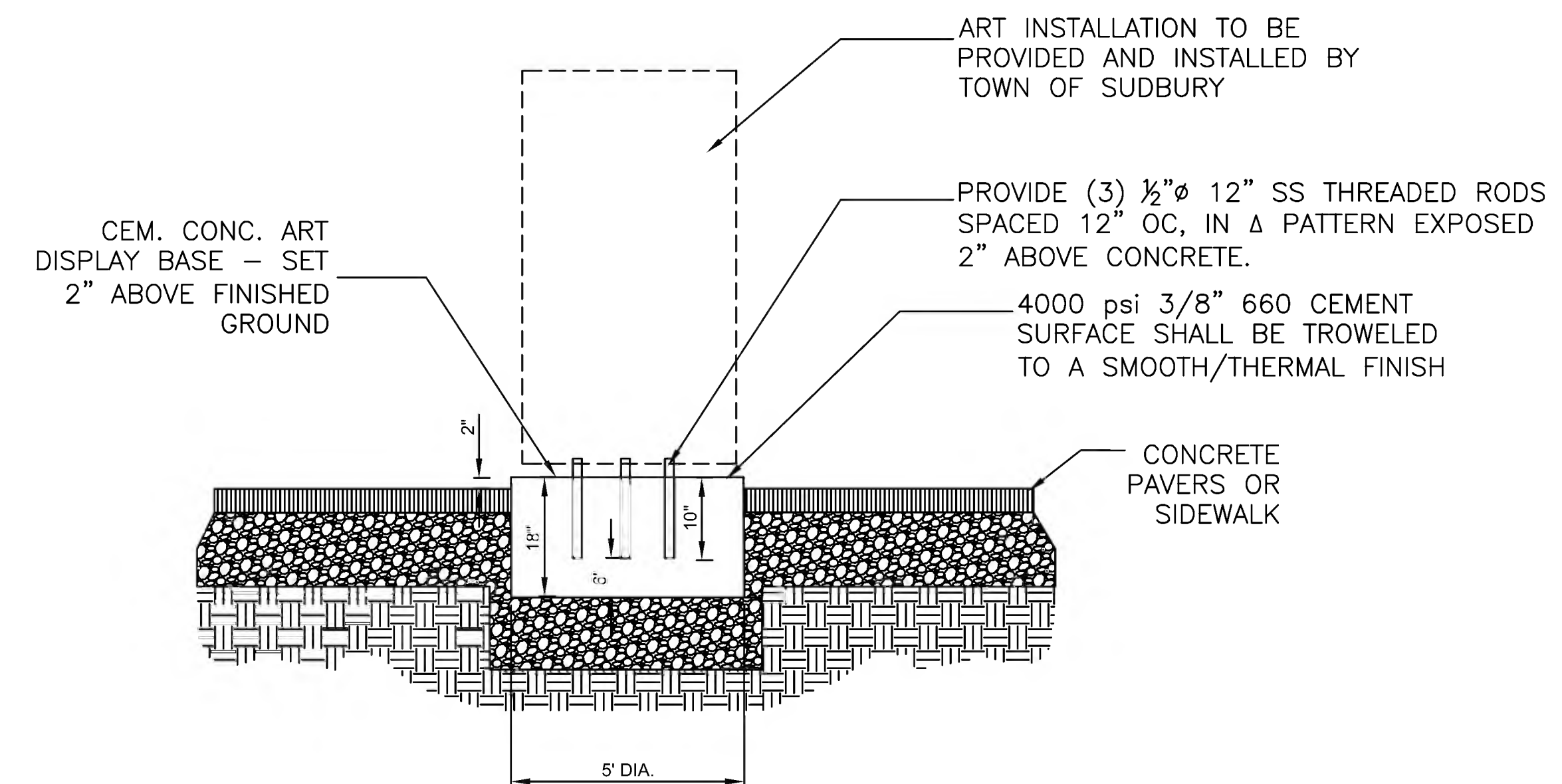
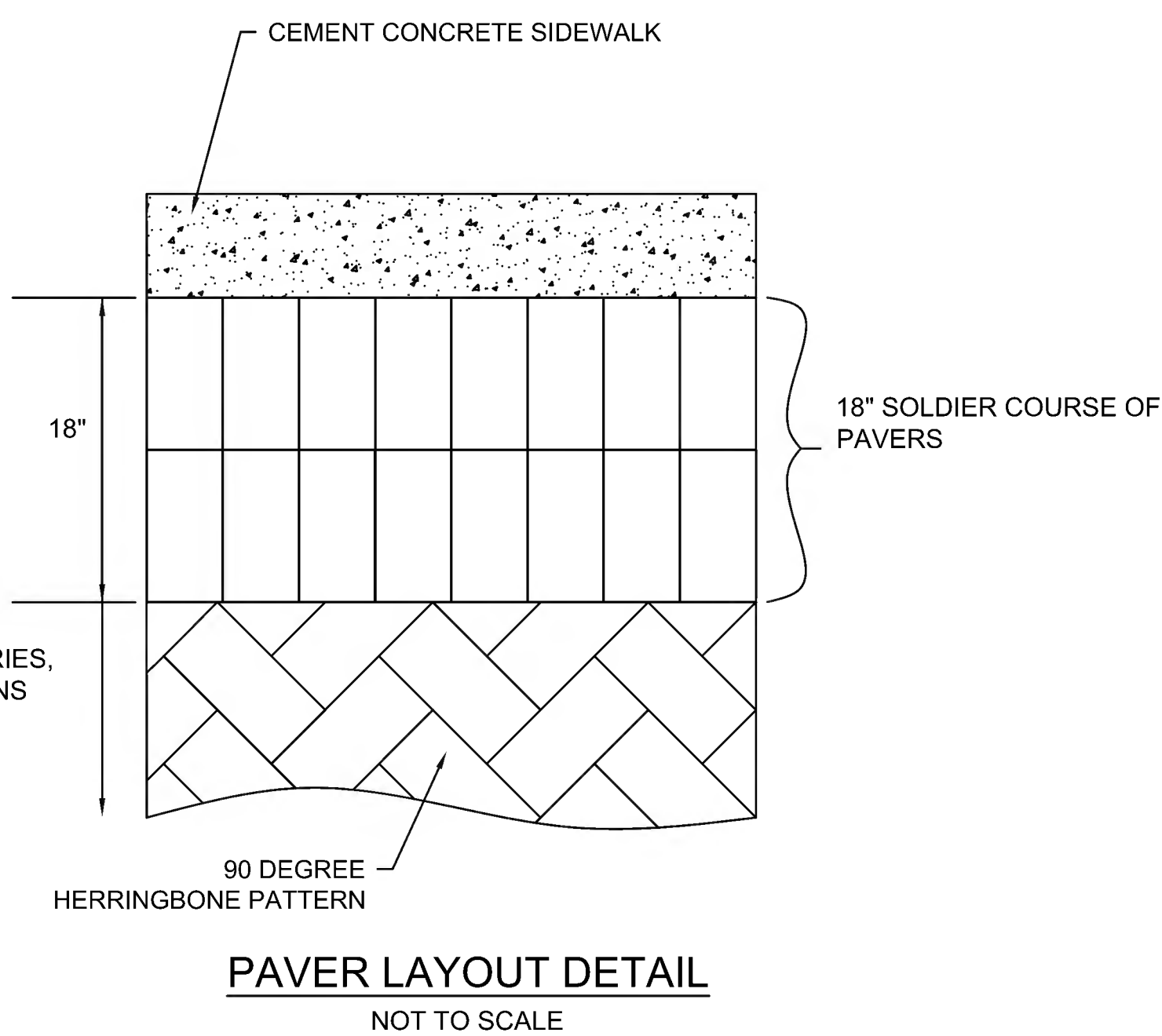

36 CONCRETE ART DISPLAY BASE
SCALE: N.T.S.

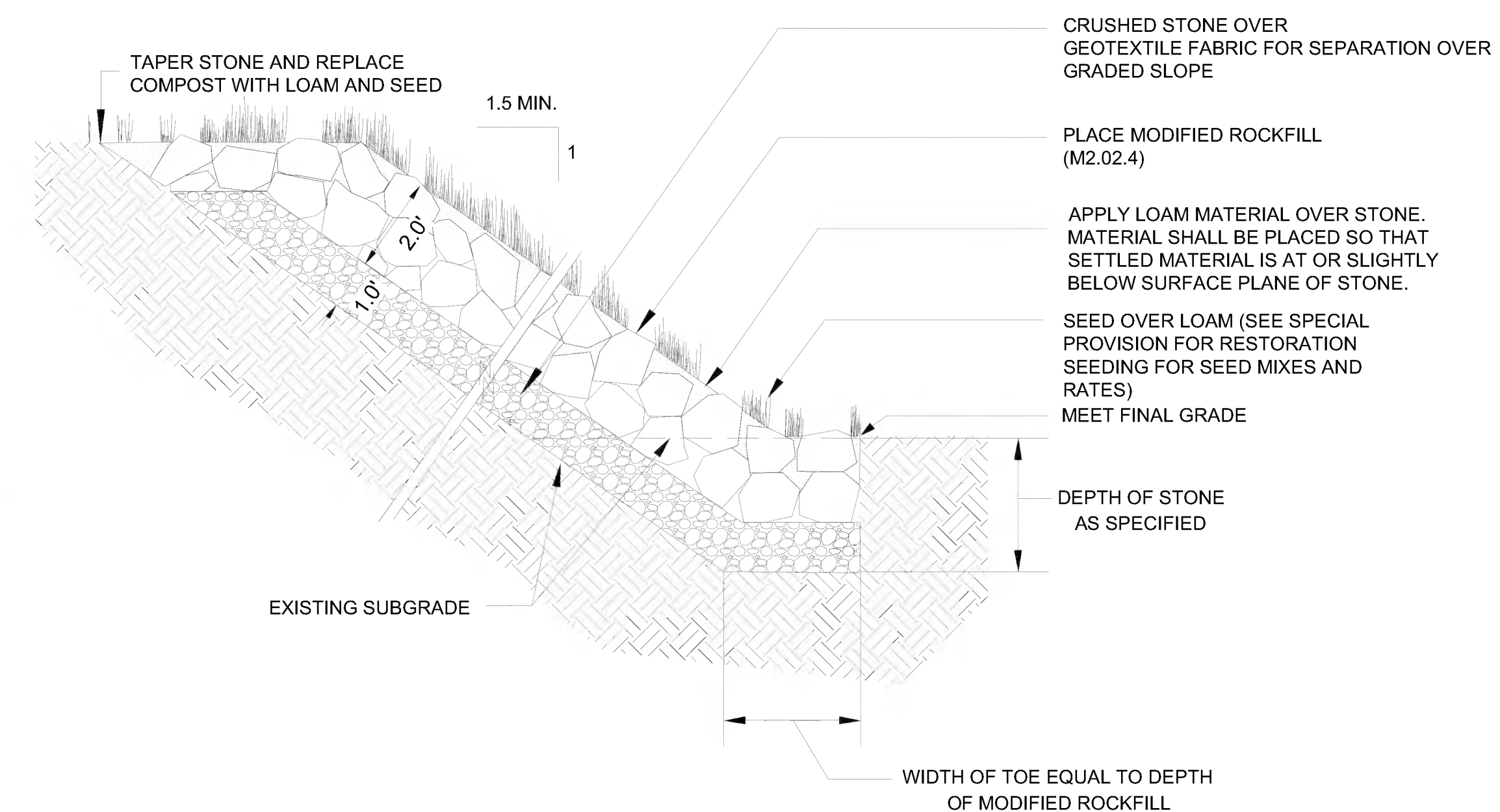

37 LOAM AND SEED OVER MODIFIED ROCKFILL
SCALE: N.T.S.

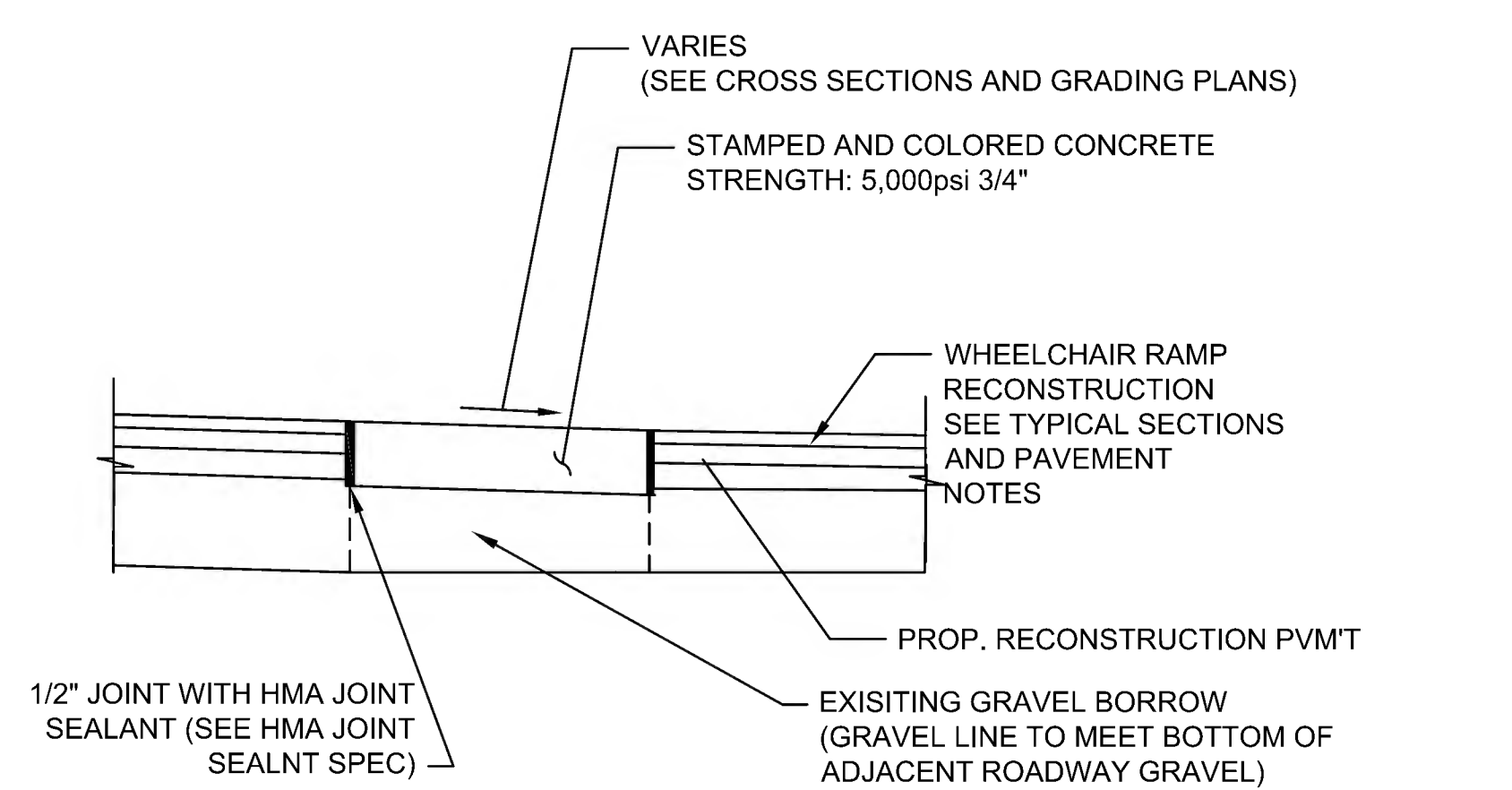

38 STAMPED & COLORED CONCRETE MEDIAN
- COLONIAL RED
SCALE: N.T.S.

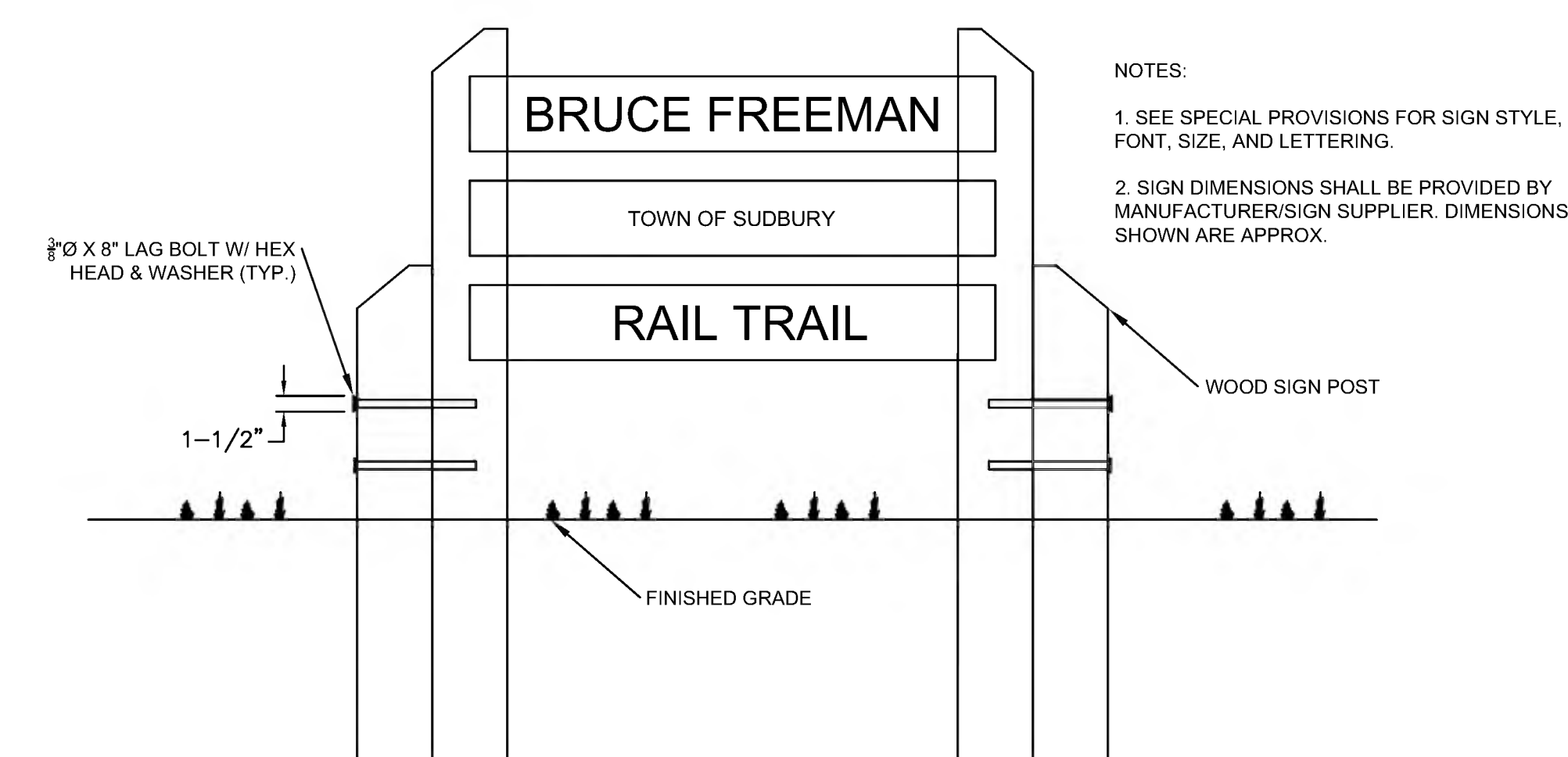

39 BRUCE FREEMAN RAIL TRAIL ENTRANCE SIGN
SCALE: N.T.S.

120-277 VOLT ELECTRIC PHOTO CONTROL
LOCKING TYPE MOUNTING

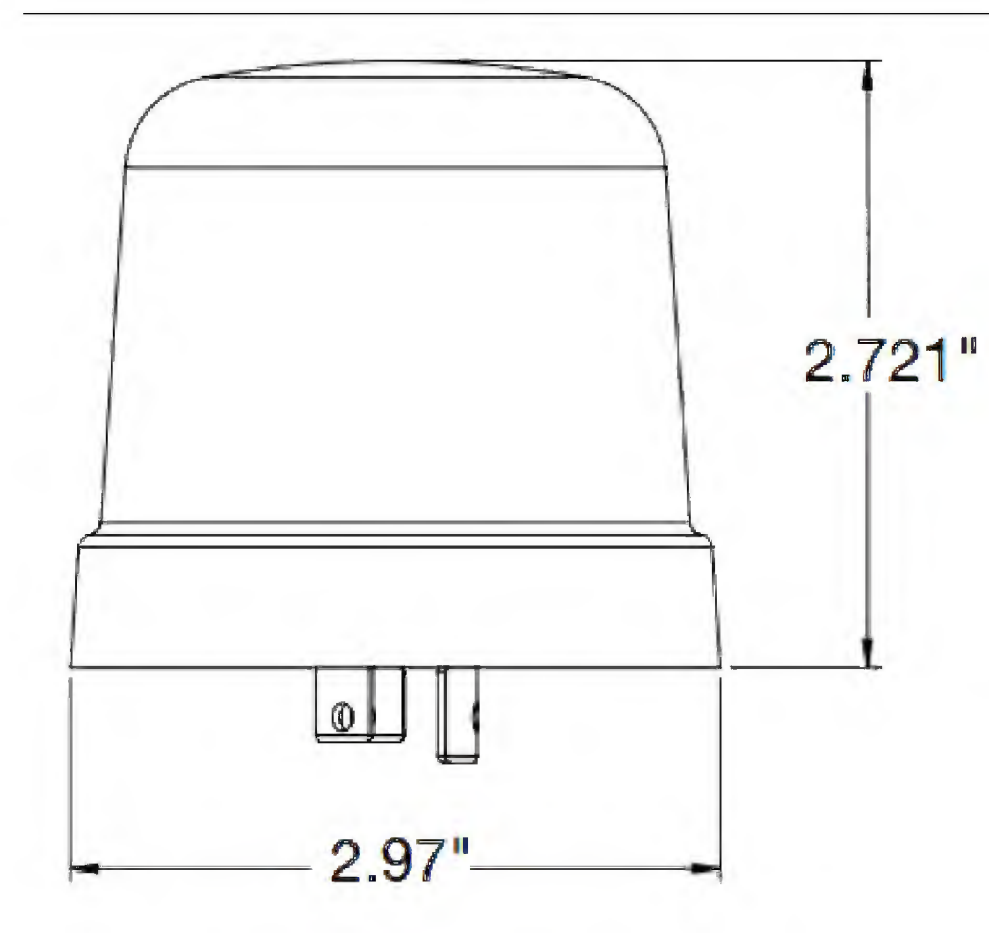

LED STREET/AREA LUMINARE

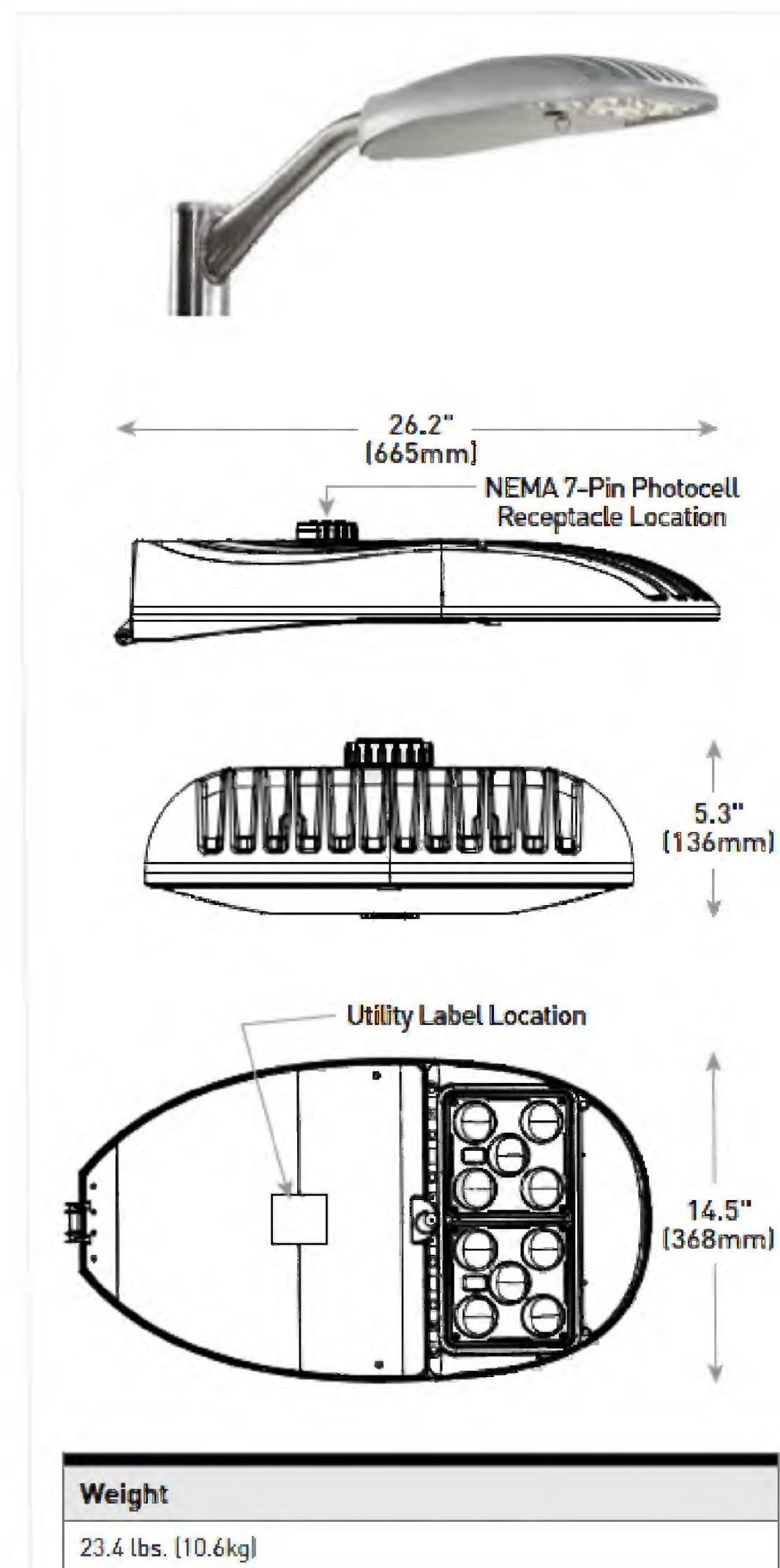

NOTES:

1. TO BE INSTALLED PER CITY STANDARD
2. HORIZONTAL TENSION MOUNTING
3. DIE CAST ALUMINUM HOUSING
4. INPUT VOLTAGE 120V - 277V
5. TO MEET ANSI C136.31-2001 AND 3G BRIDGE AND OVERPASS VIBRATION STANDARDS
6. TO DELIVER UP TO 23,800 LUMENS
7. WITH EFFICACY UP TO 139 LPW
8. CCT: 2700K, 3000K, 4000K, 5000K, 5700K

40 LED STREET/AREA LUMINARE (CITY STANDARD)
SCALE: N.T.S.

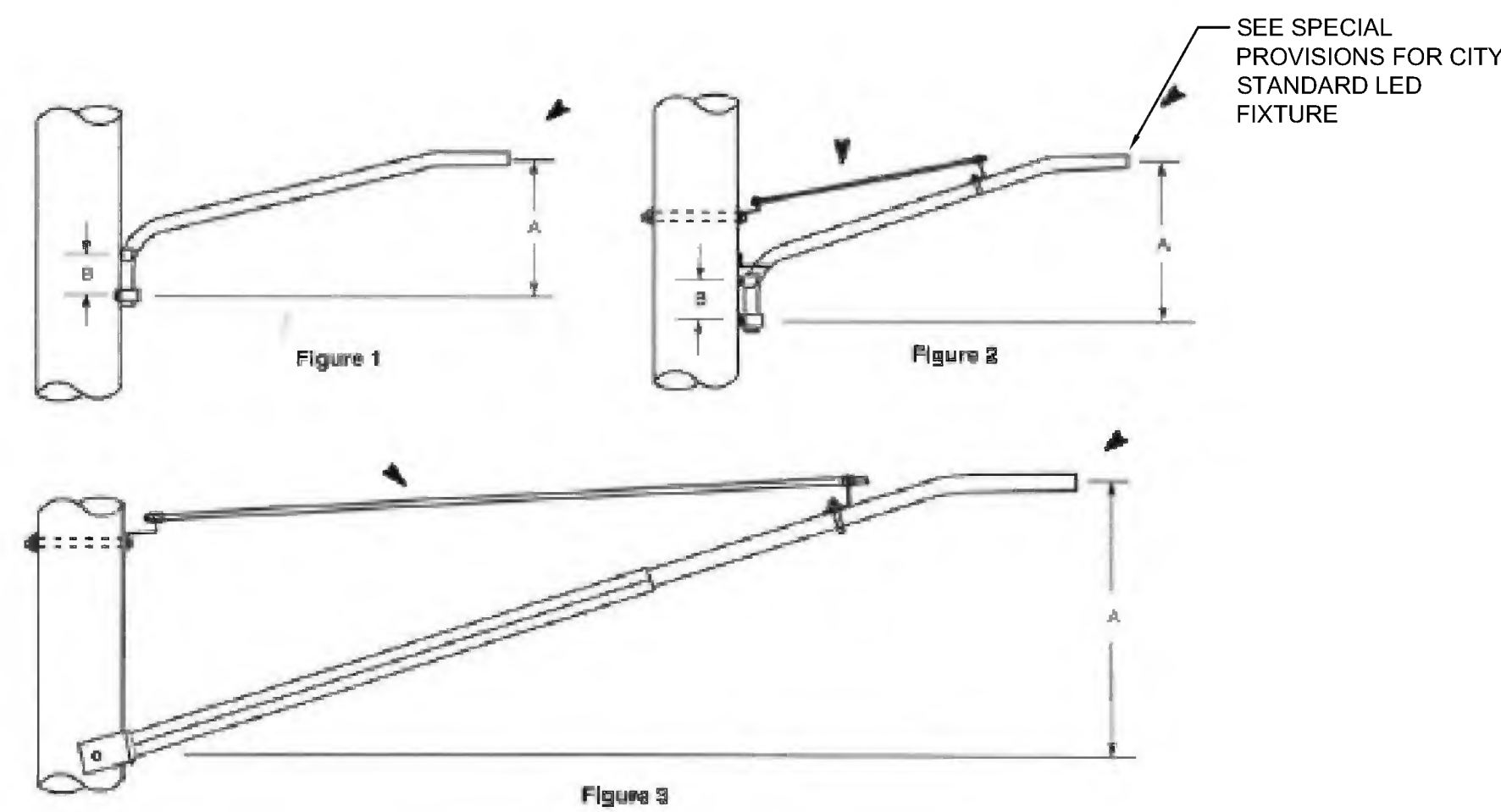

Bracket Size	Bracket Style Figure No.	Approximate Dimensions in Inches		Item Number	DTR 21.112 Pagebook Variations
		A	B		
1 1/4" x 4"	1	18-19	11	511567	A thru C
1 1/4" x 6"	2	24-30	8-11	511568	D thru F
1 1/4" x 8"	2	19-31	8-13	511569	G thru I
1 1/4" x 10"	2	35-48	12-13	511570	J thru L
1 1/4" x 12"	3	40-43	—	511571	M thru O
1 1/4" x 16"	3	56-58	—	511572	P thru R
2" x 20"	3	67-73	—	511573	S thru U
2" x 8"	2	30	9	511496	V thru X

Notes

1. Dimensions shown do not necessarily apply to brackets purchased before 1967.
2. Variations shown depend on application.

DESIGNED BY	AREA AND MUNICIPAL - GALVANIZED STEEL STREET LIGHT BRACKET FOR WOOD POLES		
APPROVED BY	EVERSOURCE ENERGY	DESIGN & APPLICATION STANDARD	DTR 21.111 9

41 HIGHWAY LIGHTING FIXTURE ARM
SCALE: N.T.S.

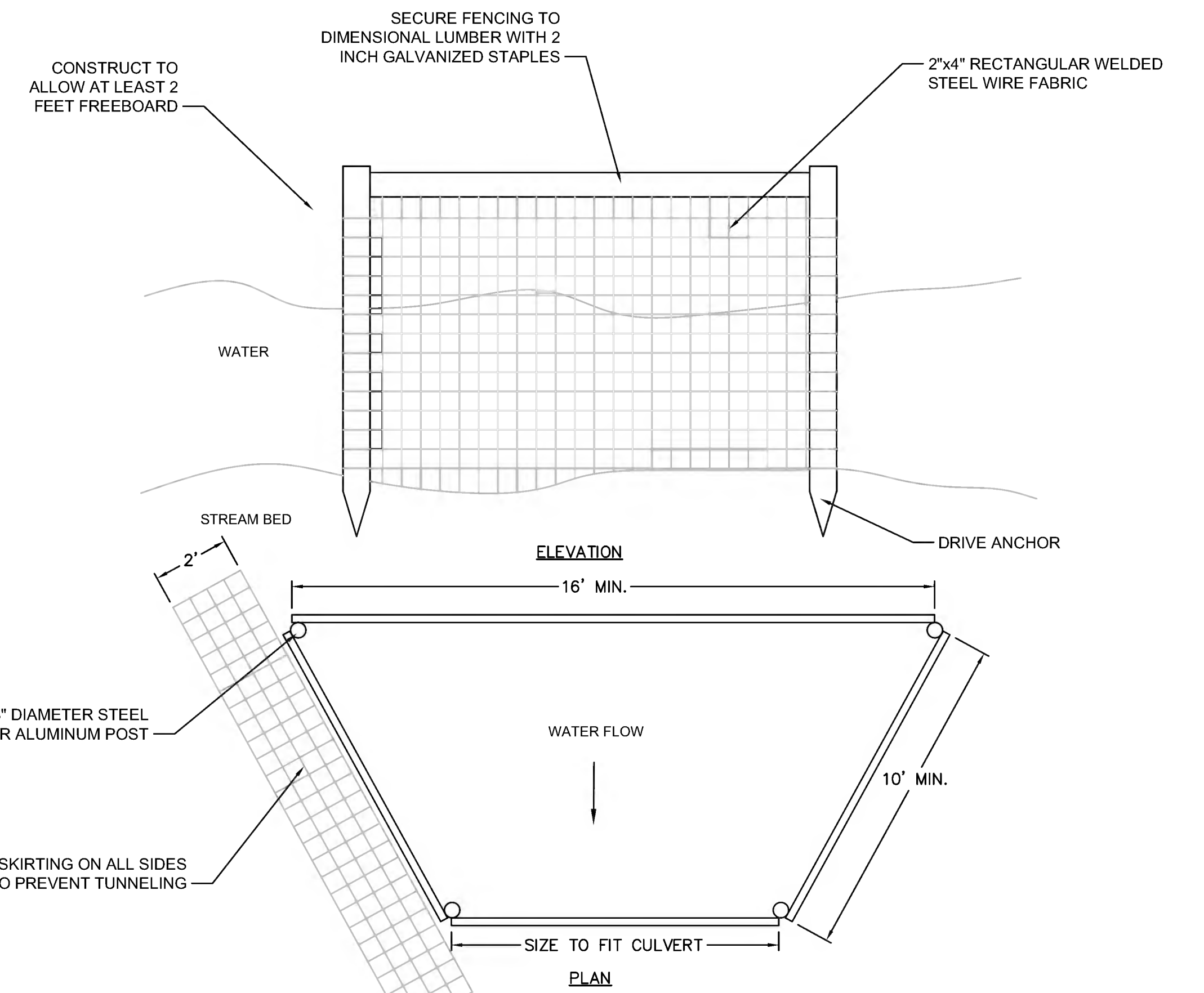

42 TRAPAZOIDAL AQUATIC EXCLUSIONARY FENCING
SCALE: N.T.S.

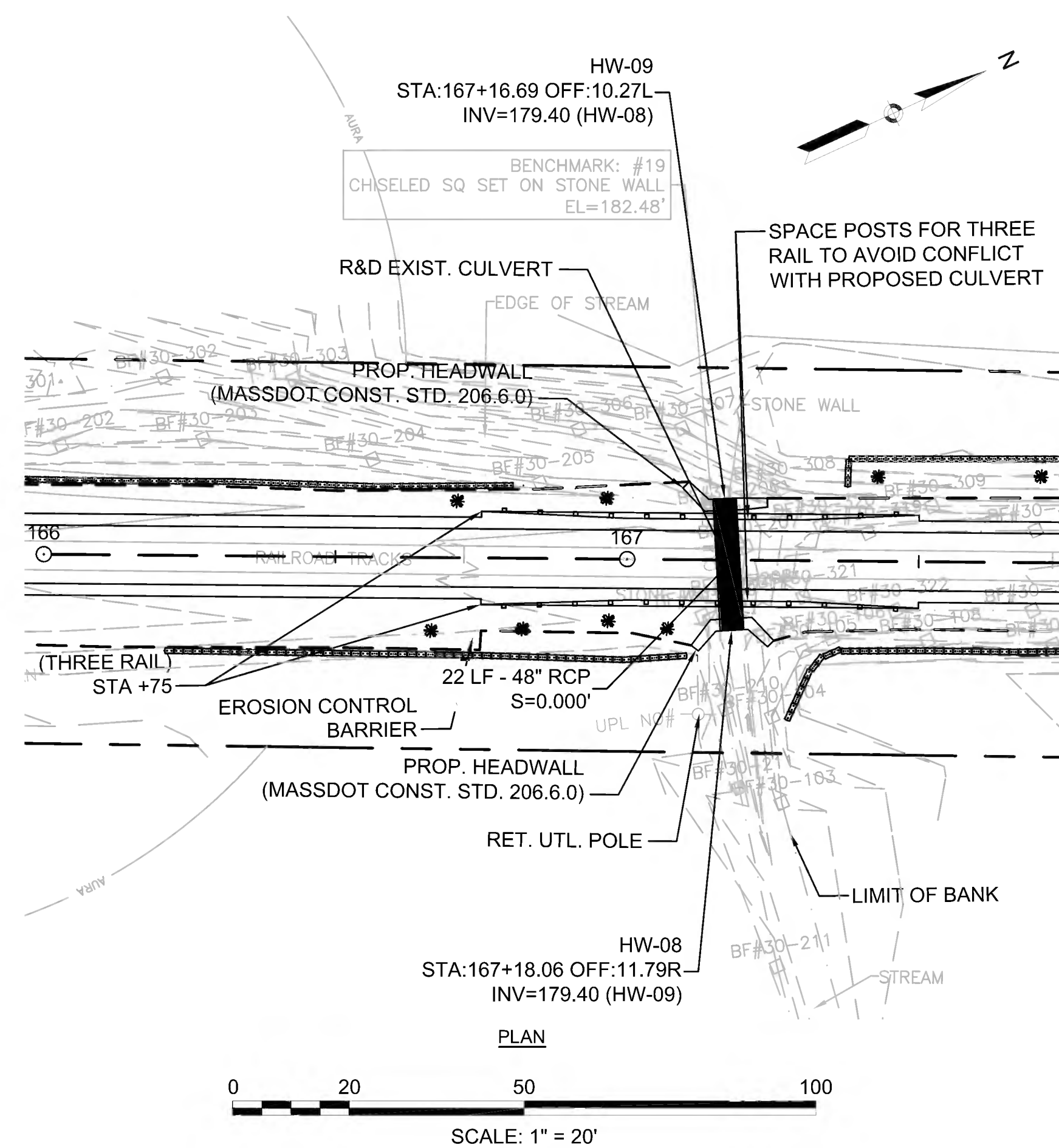
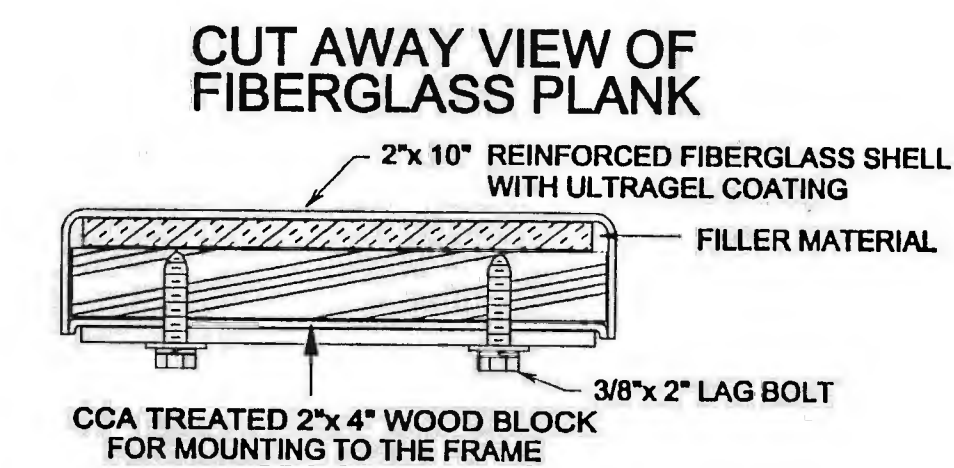
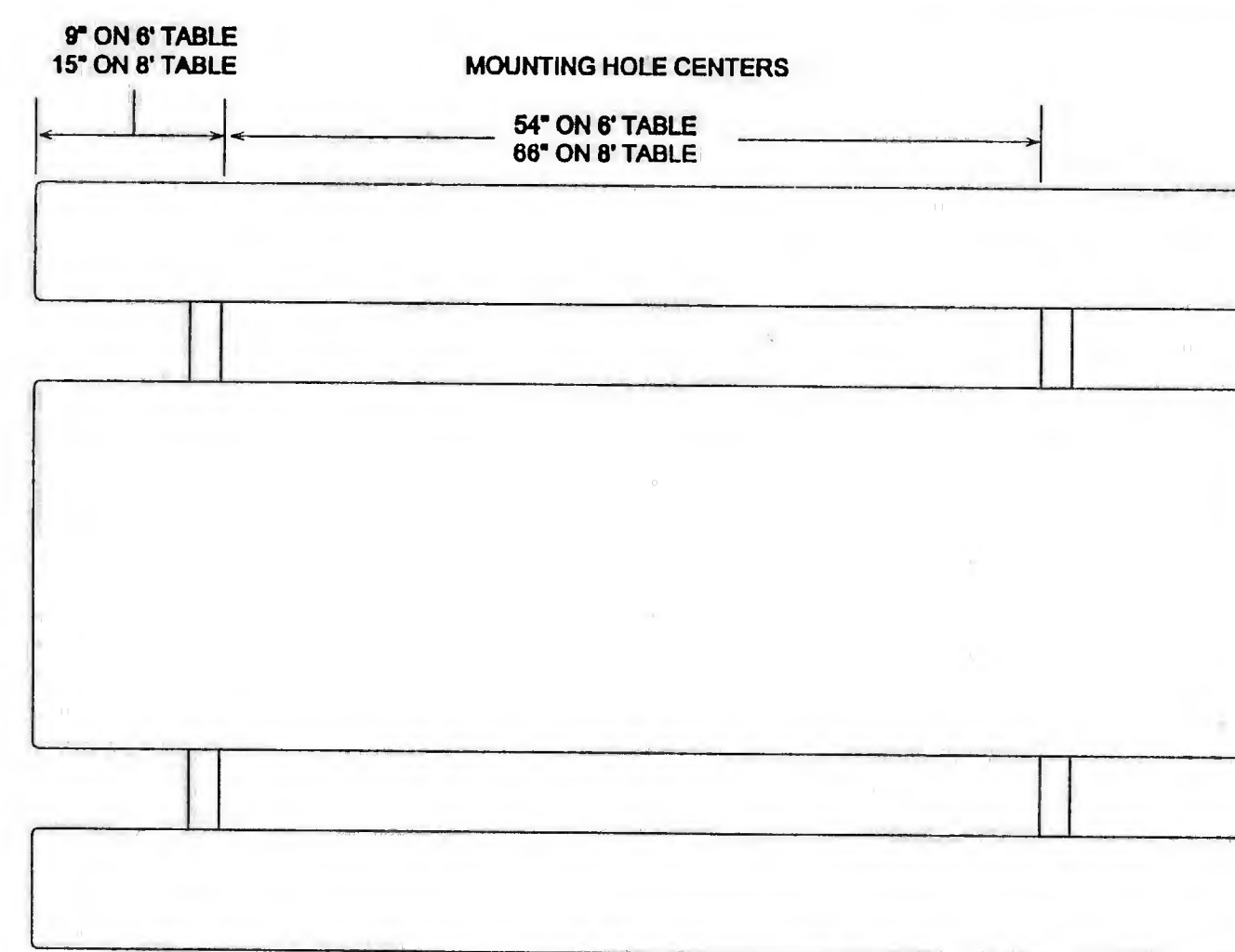
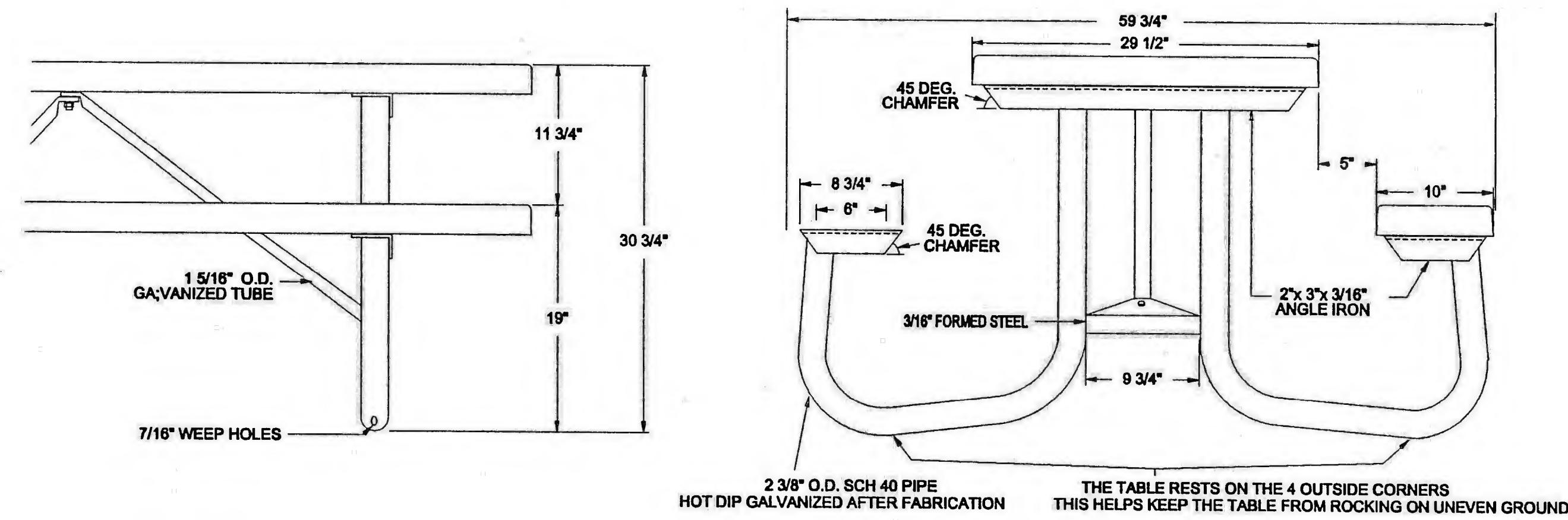

43 PICNIC TABLE
SCALE: AS NOTED

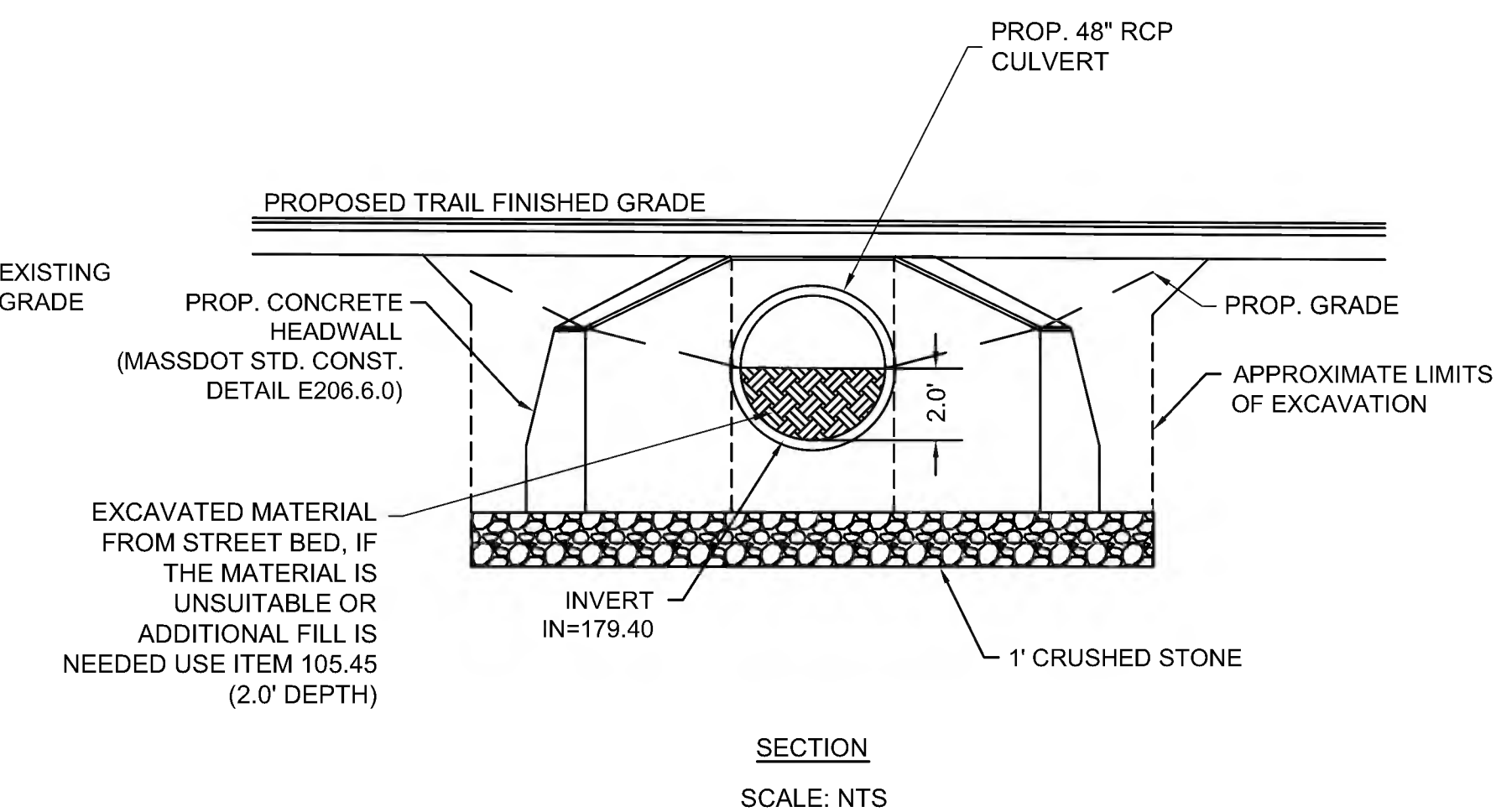
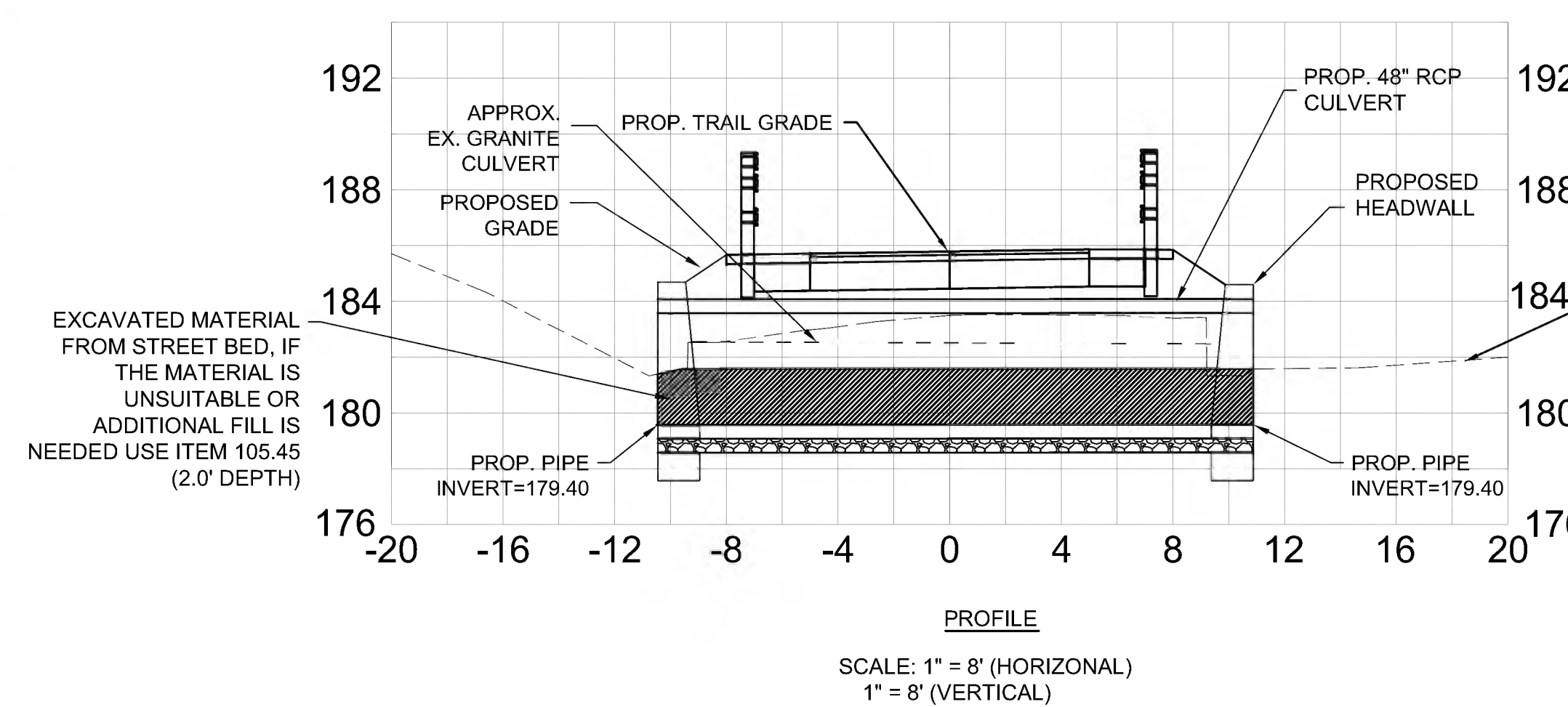

NOTE:
IF ADDITIONAL STREAM BED MATERIAL IS NEEDED, ITEM 105.45 SUPPLEMENTAL BORROW FOR NATIVE MATERIAL SHALL BE USED IN ADDITION TO EXCAVATED ONSITE MATERIAL.

44 CONCRETE CULVERT REPLACEMENT - STA 167+17
SCALE: AS NOTED

- NOTES:
 1. ALL RAMP ARE TO BE CONSTRUCTED WITH 6" THICKNESS OF CEMENT CONCRETE.
 2. DETECTABLE WARNING PANELS SHALL BE PLASTIC - COLORED BRICK RED.

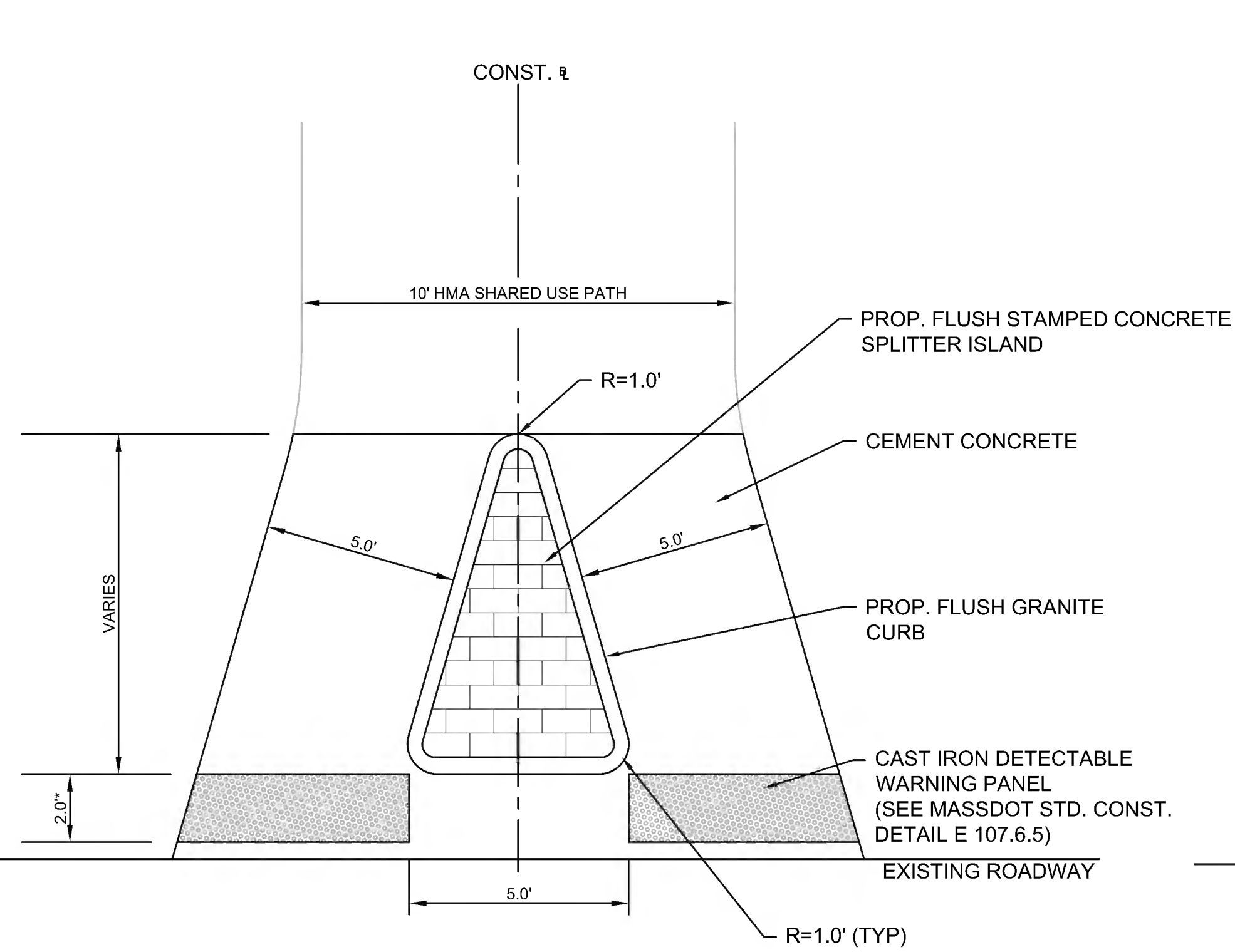

CEMENT CONCRETE RAIL TRAIL ENTRANCE WITH SPLITTER ISLAND
N.T.S.

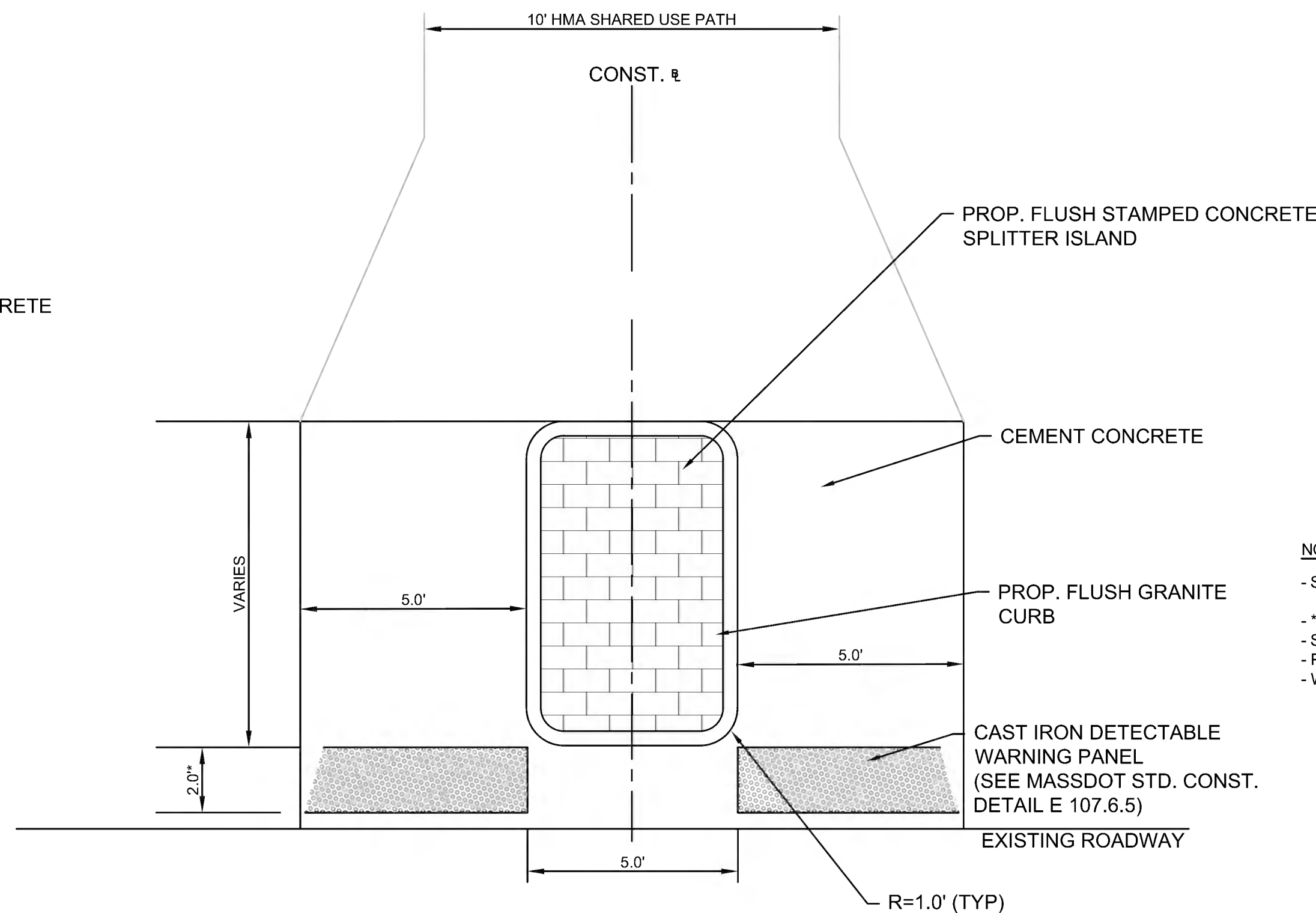

CEMENT CONCRETE RAIL TRAIL ENTRANCE WITH SPLITTER ISLAND
N.T.S.

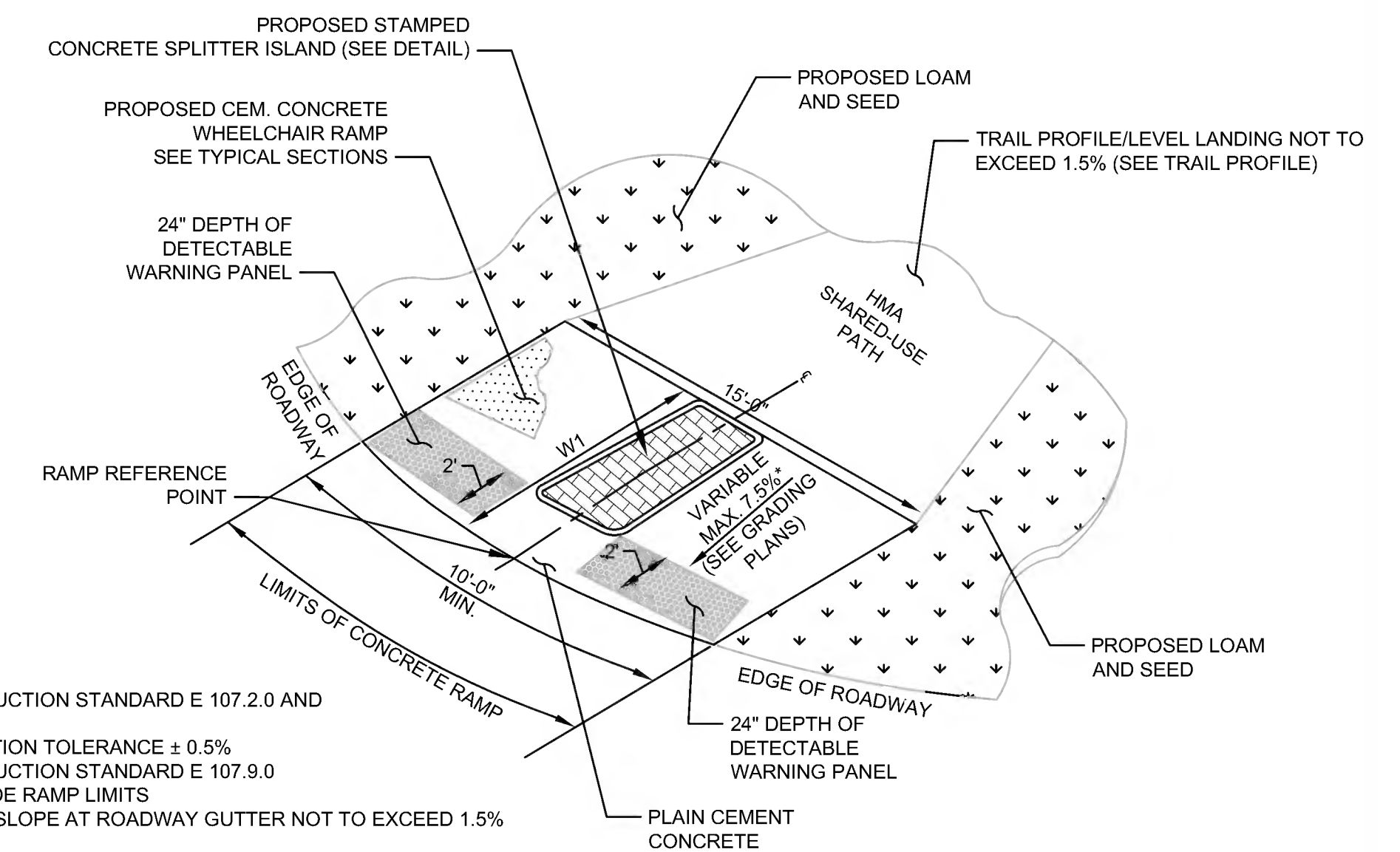

- NOTES:
 - SEE CONSTRUCTION STANDARD E 107.2.0 AND E 107.6.5
 - * CONSTRUCTION TOLERANCE ± 0.5%
 - ** CONSTRUCTION STANDARD E 107.9.0
 - PC/PT OUTSIDE RAMP LIMITS
 - WCR CROSS SLOPE AT ROADWAY GUTTER NOT TO EXCEED 1.5%

**TYPE A SHARED USE PATH
ENTRANCE/EXIT RAMP ON CORNER RADIUS**
N.T.S.

WCR#	RAMP REFERENCE POINT	WIDTH OF RAMP ENTRANCE (10'-0" MIN.)	LENGTH OF PRIMARY RAMP (W1)	CORNER RADIUS
A1	108+59.82 UNION AVE	17'-1"	12'-9"	20'
A2	175+53.03 HUDSON RD	15'-8"	12'-7"	25'

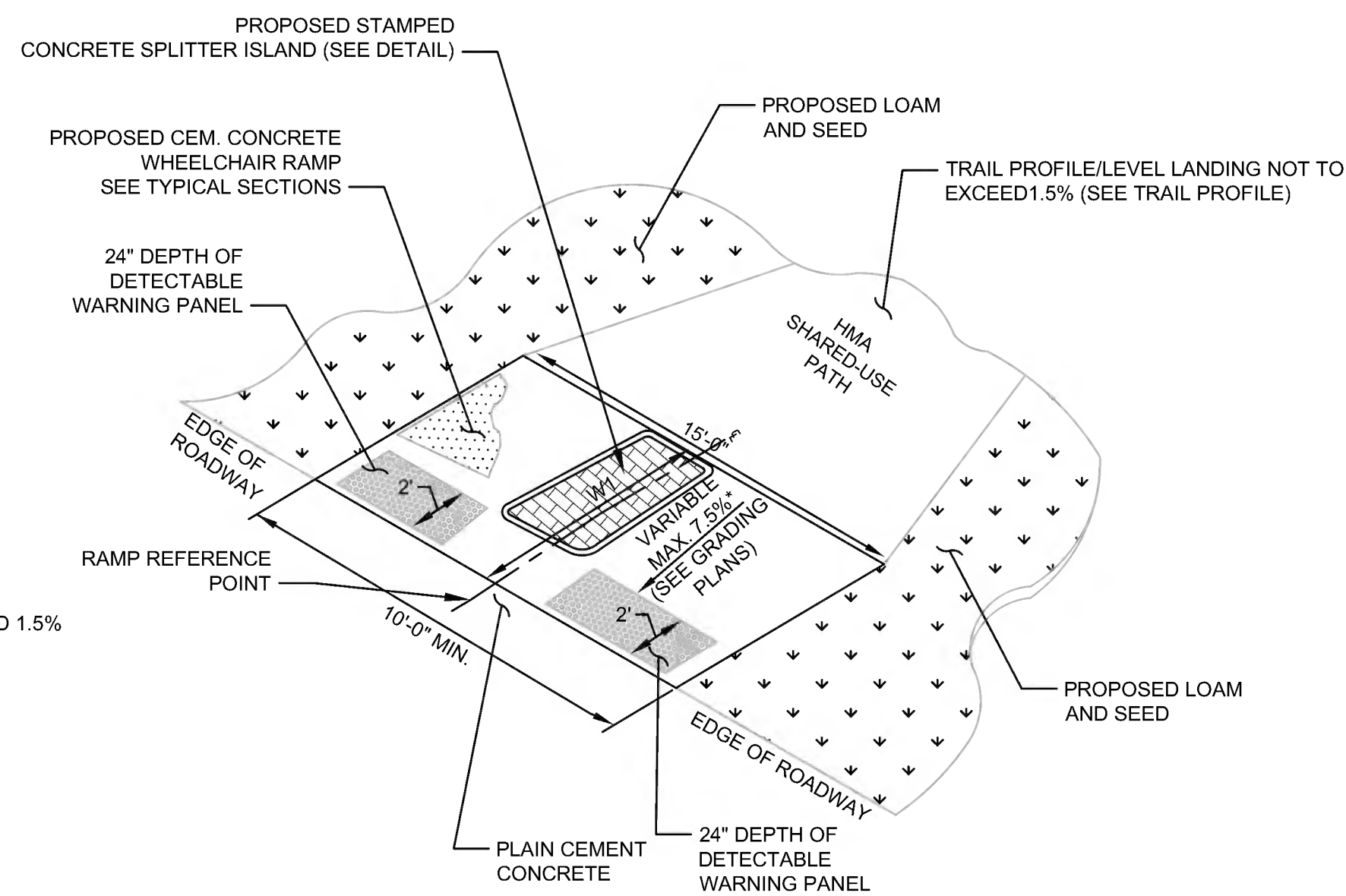
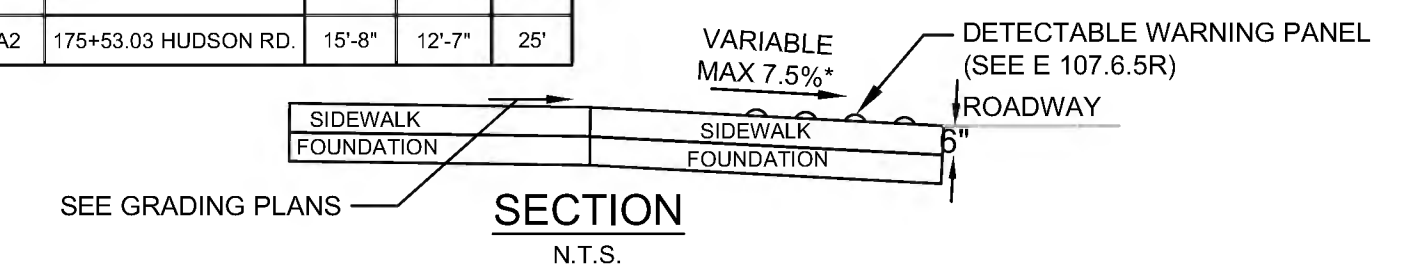

- NOTES:
 - SEE CONSTRUCTION STANDARD E 107.2.0 AND E 107.6.5
 - * CONSTRUCTION TOLERANCE ± 0.5%
 - ** CONSTRUCTION STANDARD E 107.9.0
 - PC/PT OUTSIDE RAMP LIMITS
 - WCR CROSS SLOPE AT ROADWAY GUTTER NOT TO EXCEED 1.5%

WCR#	RAMP REFERENCE POINT	WIDTH OF RAMP ENTRANCE (10'-0" MIN.)	LENGTH OF PRIMARY RAMP (W1)
B1	108+83.74 UNION AVE.	16'-5"	12'-7"
B2	115+96.13 CODJER LN.	15'-10"	12'-8"
B3	116+20.92 CODJER LN.	15'-1"	12'-7"
B4	142+82.00 OLD LANCASTER RD.	16'-2"	12'-7"
B5	215+94.04 MORSE RD.	16'-0"	12'-7"
B6	274+94.44 HAYNES RD.	15'-0"	12'-3"
B7	275+15.00 HAYNES RD.	15'-0"	12'-9"
B8	307+75.00 NORTH RD.	15'-7"	12'-7"

**TYPE B SHARED USE PATH
ENTRANCE/EXIT RAMP**
N.T.S.

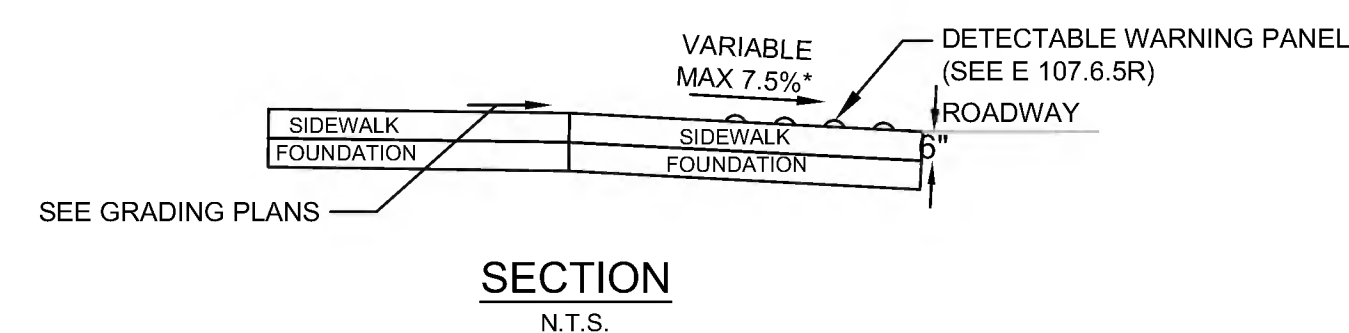

- NOTES:
 - SEE CONSTRUCTION STANDARD E 107.6.9 AND E 107.6.5
 - * CONSTRUCTION TOLERANCE ± 0.5%
 - ** NON-WALKING SURFACE
 - WCR CROSS SLOPE AT ROADWAY GUTTER NOT TO EXCEED 1.5%

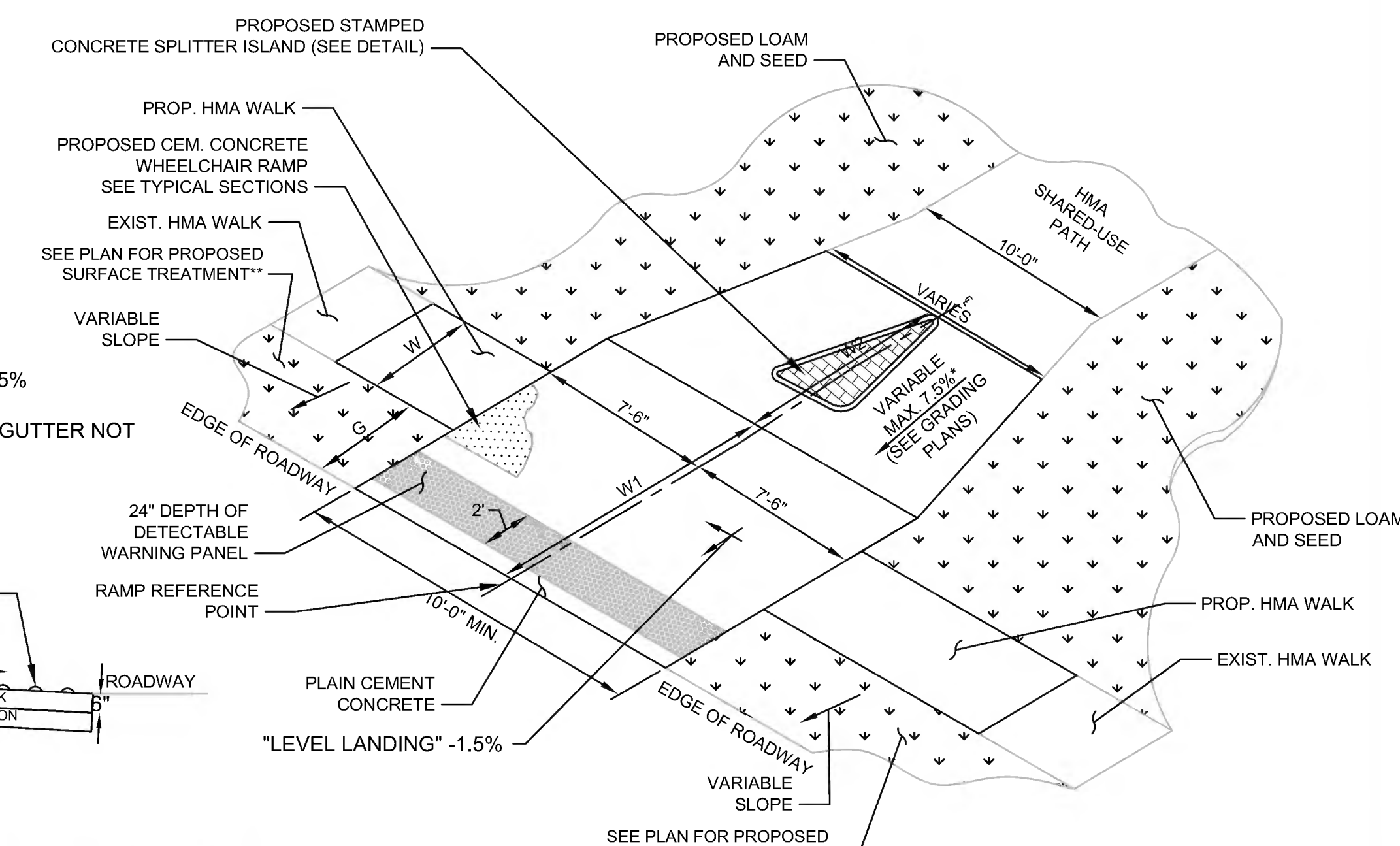
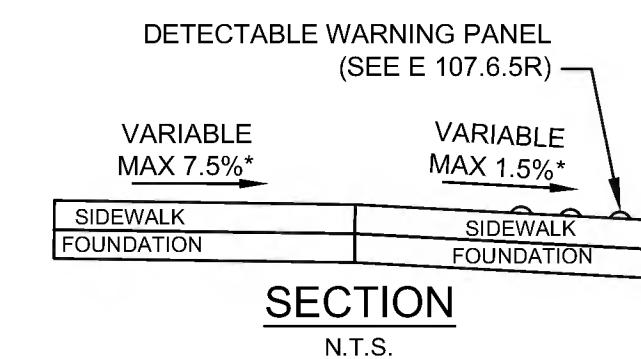

**TYPE C SHARED USE PATH
ENTRANCE/EXIT RAMP**
N.T.S.

WCR#	RAMP REFERENCE POINT	WIDTH OF SIDEWALK (W)	WIDTH OF BUFFER STRIP (S)	WIDTH OF RAMP ENTRANCE (10'-0" MIN.)	LENGTH OF PRIMARY RAMP (W1)	LENGTH OF SECONDARY RAMP (W2)
C1	143+04.71 OLD LANCASTER RD.	4'-6"	4'-7"	15'-00"	11'-00"	10'-00"
C2	215+73.57 MORSE RD.	5'-0"	5'-6"	15'-11"	15'-6"	10'-00"
C3	307+48.47 NORTH RD.	8'-0"	4'-4"	15'-6"	19'-0"	10'-0"

- NOTES:**
- ALL RAMP ARE TO BE CONSTRUCTED WITH 6" THICKNESS OF CEMENT CONCRETE.
 - DETECTABLE WARNING PANELS SHALL BE PLASTIC - COLORED BRICK RED.

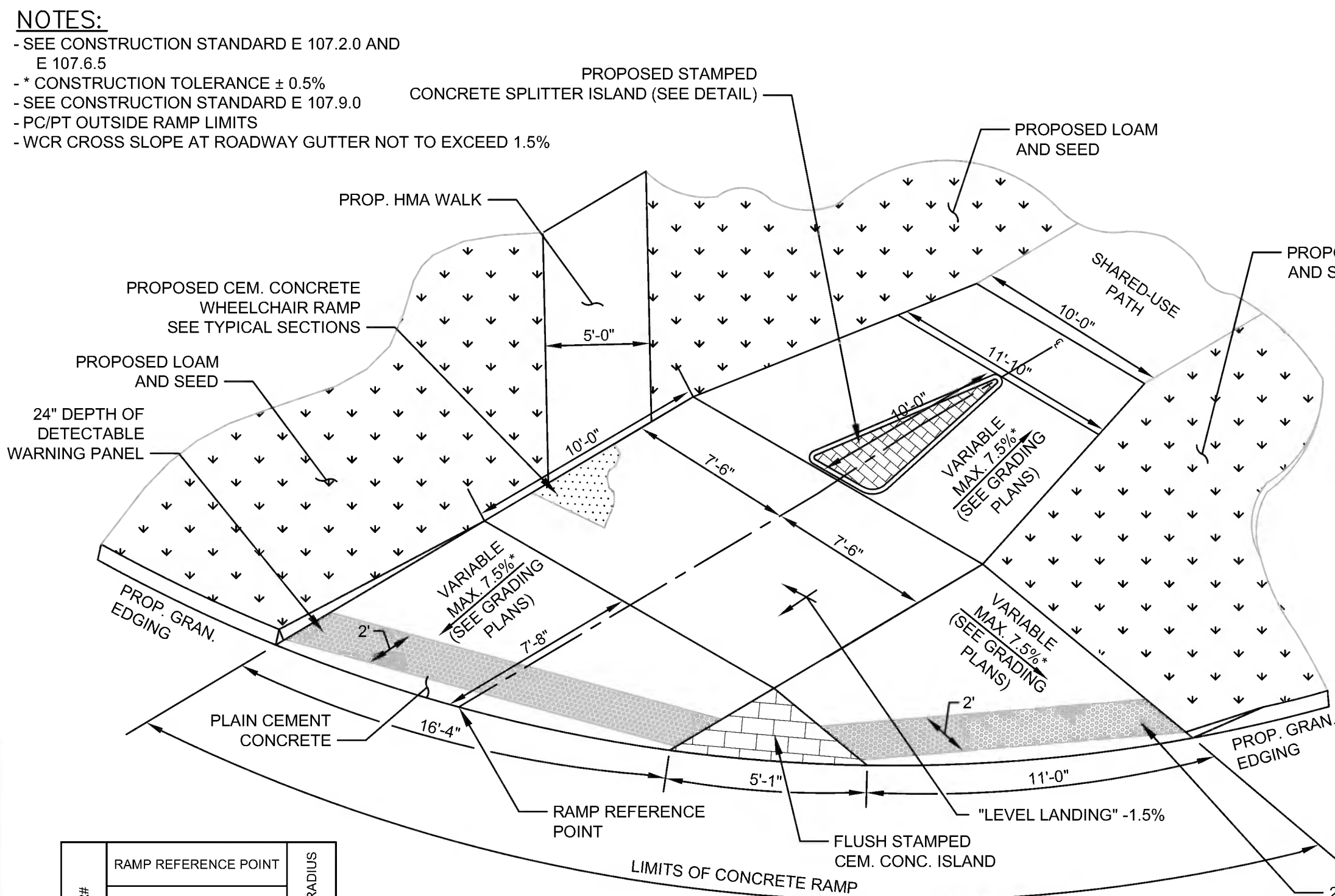

WCR#	RAMP REFERENCE POINT	CORNER RADIUS
D1	175+09.54 HUDSON RD	40'

**TYPE D SHARED USE PATH
ENTRANCE/EXIT RAMP ON CORNER RADIUS AT
PEAKHAM/HUDSON ROAD INTERSECIOTN**
N.T.S.

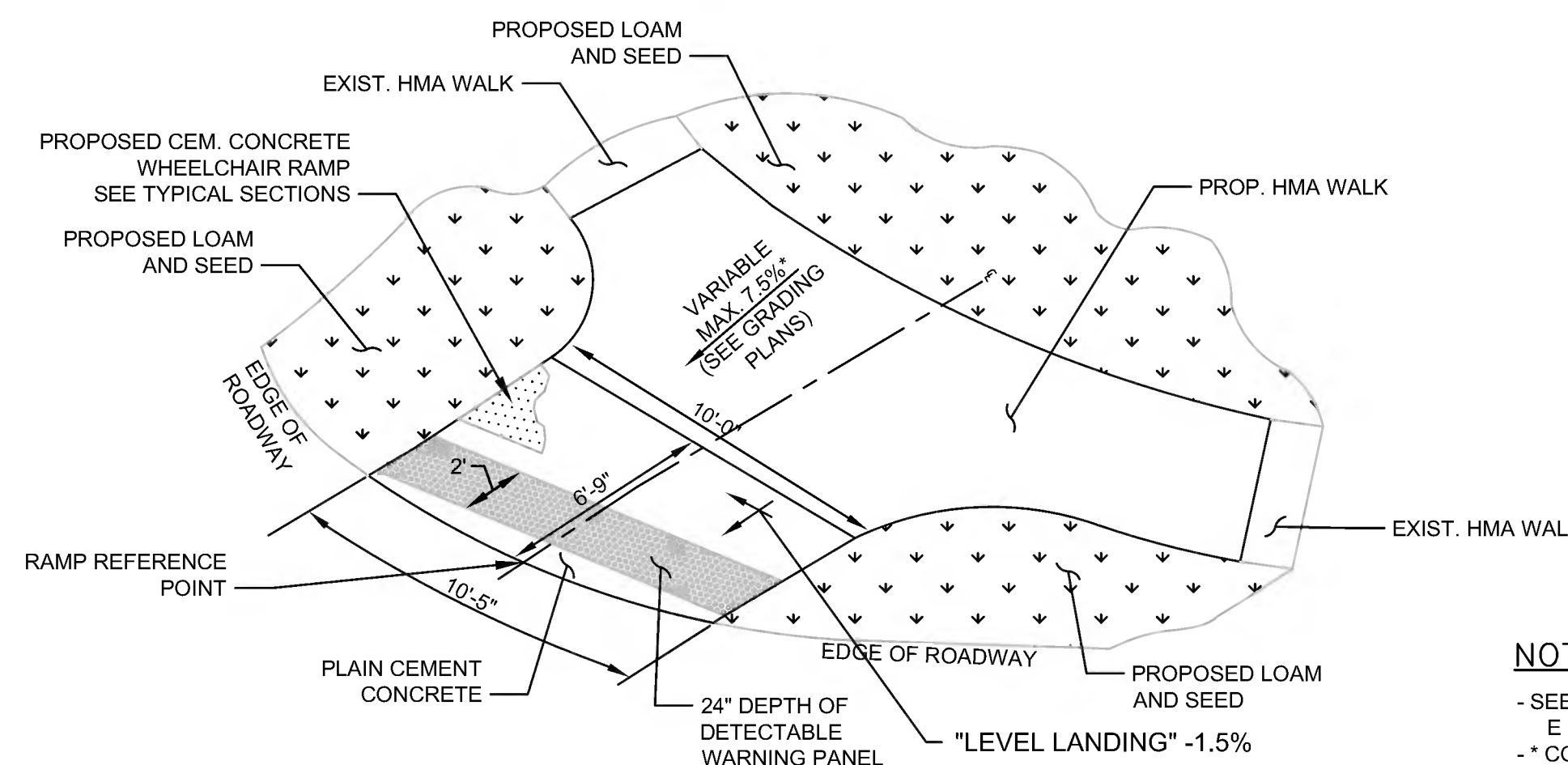
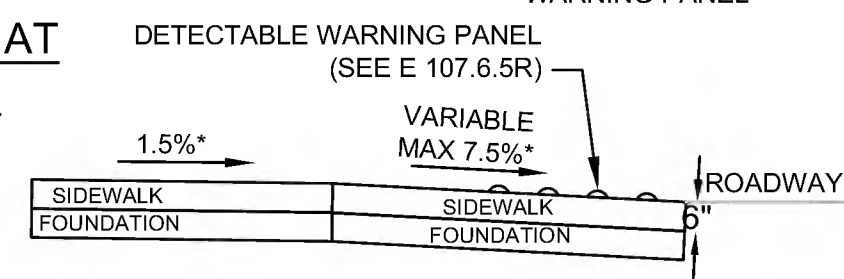

- NOTES:**
- SEE CONSTRUCTION STANDARD E 107.2.0 AND E 107.6.5
 - * CONSTRUCTION TOLERANCE ± 0.5%
 - ** CONSTRUCTION STANDARD E 107.9.0
 - PC/PT OUTSIDE RAMP LIMITS
 - WCR CROSS SLOPE AT ROADWAY GUTTER NOT TO EXCEED 1.5%

**TYPE E WHEELCHAIR RAMP
ON CORNER RADIUS AT
PEAKHAM/HUDSON ROAD INTERSECTION**
N.T.S.

WCR#	RAMP REFERENCE POINT	STATION/ROADWAY	OFFSET	WIDTH OF RAMP ENTRANCE (10'-0" MIN.)	LENGTH OF PRIMARY RAMP (FT.)	CORNER RADIUS
E1	601+76.54 PEAKHAM RD	20.43'	10'-5"	6'-10"	40'	

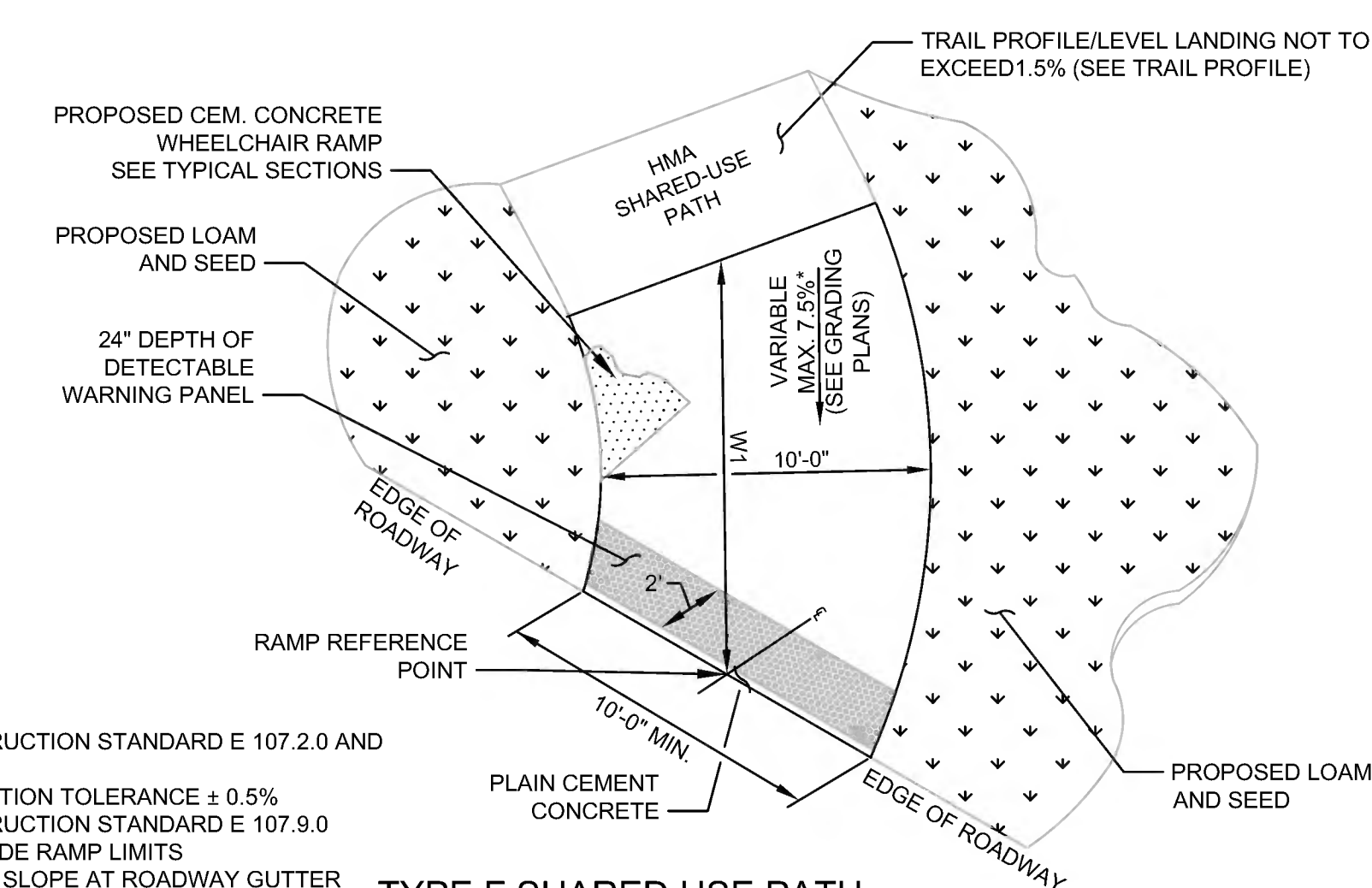
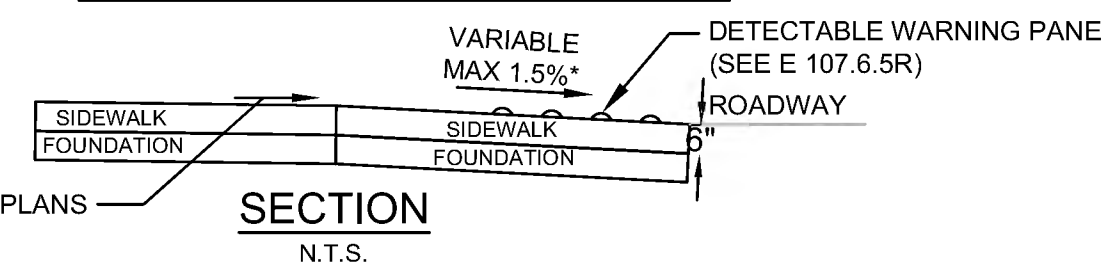

- NOTES:**
- SEE CONSTRUCTION STANDARD E 107.2.0 AND E 107.6.5
 - * CONSTRUCTION TOLERANCE ± 0.5%
 - ** CONSTRUCTION STANDARD E 107.9.0
 - PC/PT OUTSIDE RAMP LIMITS
 - WCR CROSS SLOPE AT ROADWAY GUTTER NOT TO EXCEED 1.5%

**TYPE F SHARED USE PATH
ENTRANCE/EXIT RAMP**
N.T.S.

WCR#	RAMP REFERENCE POINT	STATION/ROADWAY	WIDTH OF RAMP ENTRANCE (10'-0" MIN.)	LENGTH OF PRIMARY RAMP (FT.)
F1	284+33.98 PANTRY RD.	10'-0"	15'-11"	
F2	284+60.04 PANTRY RD.	10'-0"	15'-7"	

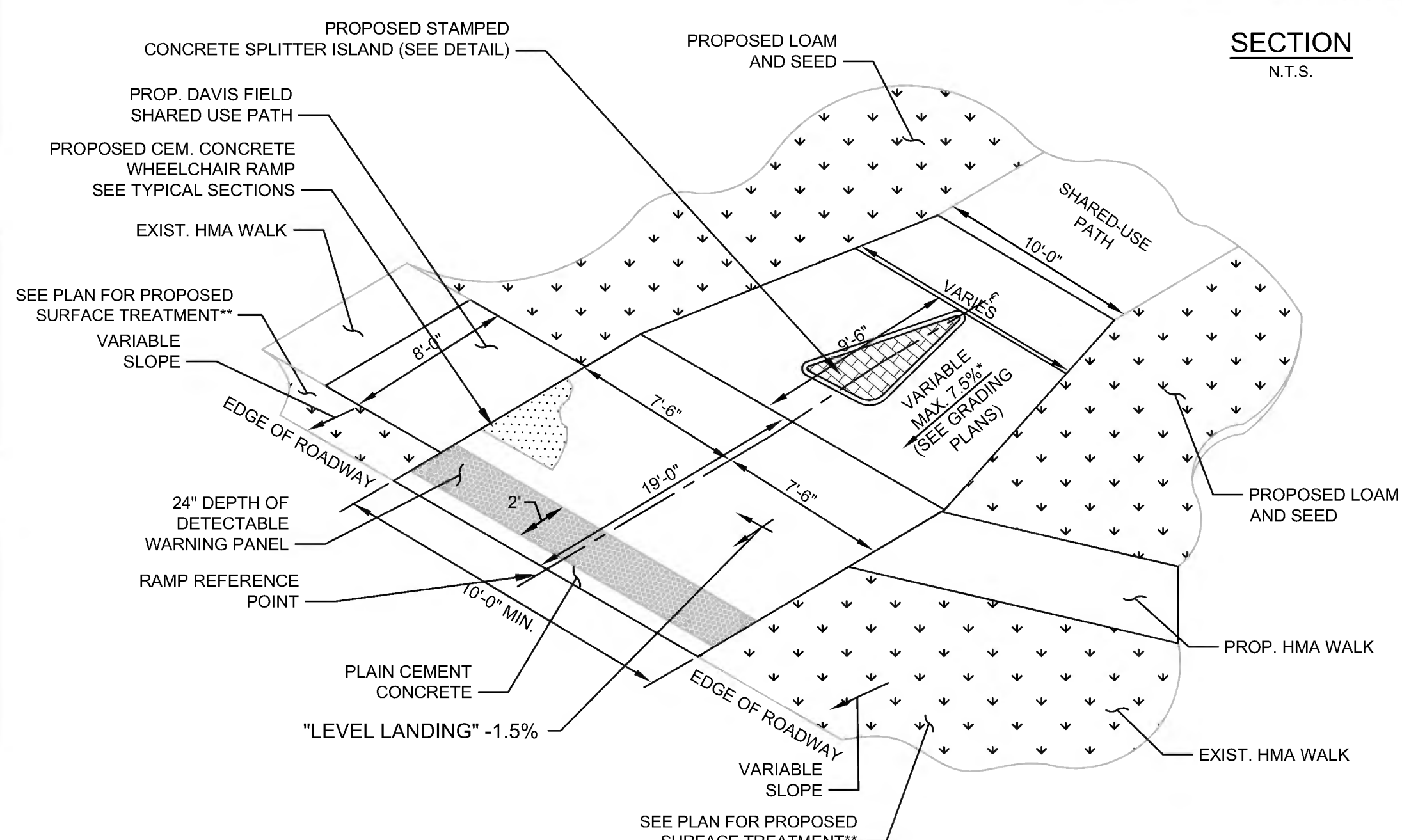
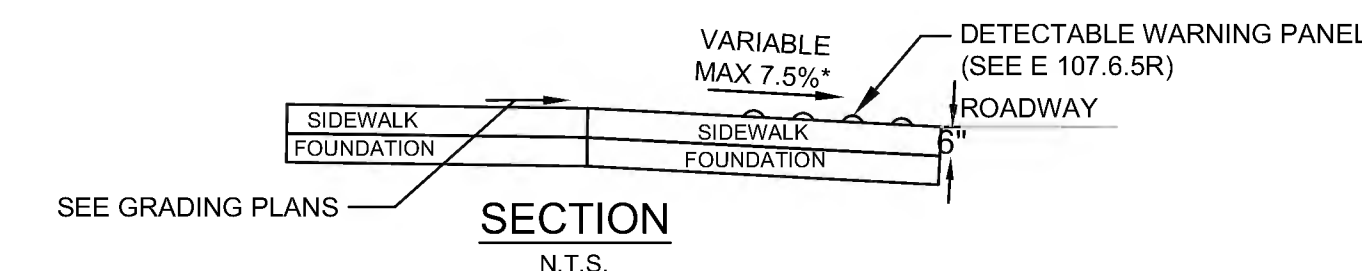

**TYPE G SHARED USE PATH
ENTRANCE/EXIT RAMP AT NORTH ROAD
STA. 307+48**
N.T.S.

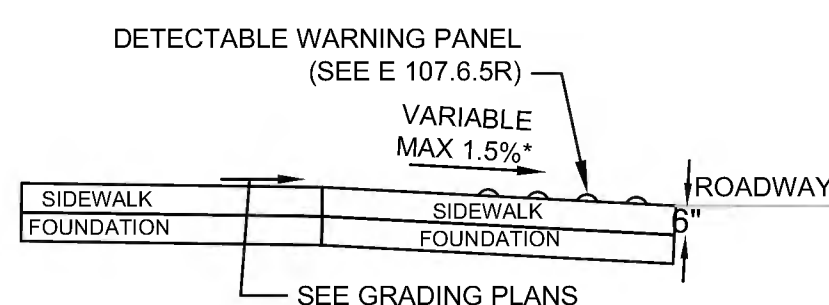

- NOTES:**
- SEE CONSTRUCTION STANDARD E 107.6.9 AND E 107.6.5
 - * CONSTRUCTION TOLERANCE ± 0.5%
 - ** NON-WALKING SURFACE
 - WCR CROSS SLOPE AT ROADWAY GUTTER NOT TO EXCEED 1.5%

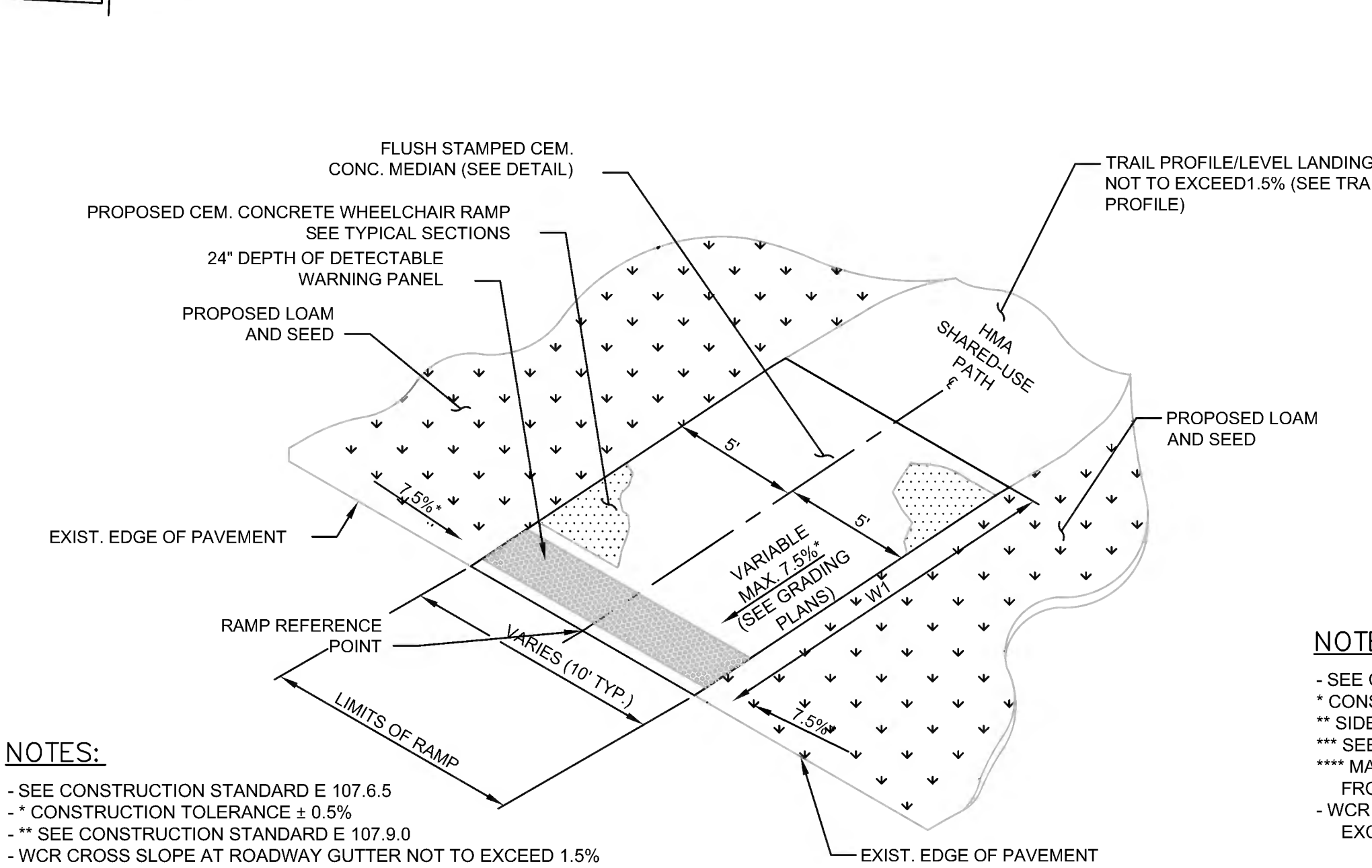

- NOTES:**
- SEE CONSTRUCTION STANDARD E 107.6.5
 - * CONSTRUCTION TOLERANCE ± 0.5%
 - ** CONSTRUCTION STANDARD E 107.9.0
 - WCR CROSS SLOPE AT ROADWAY GUTTER NOT TO EXCEED 1.5%

**TYPE H WHEELCHAIR RAMP
SHARED-USE PATH ENTRANCE/EXIT**
N.T.S.

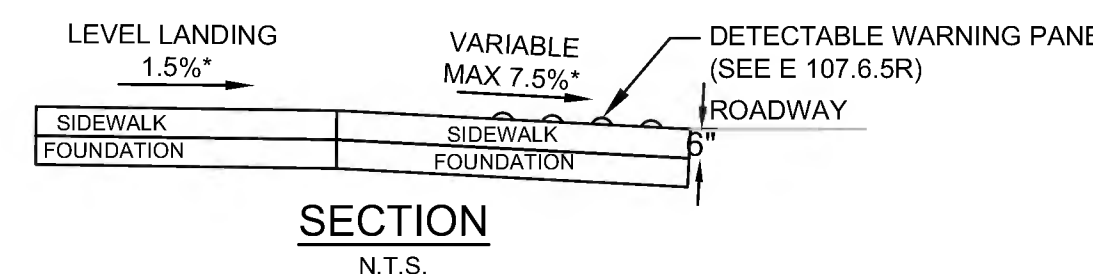

WCR#	RAMP REFERENCE POINT	STATION/ROADWAY	OFFSET	WIDTH OF RAMP ENTRANCE (10'-0" MIN.)	LENGTH OF PRIMARY RAMP (FT.)
H1	1000+80.00 PARKINSON'S LOT	-	10'-0"	5'-0"	
H2	216+60.31 BROADACRES FARM	51'-94"	10'-0"	6'-6"	
H3	320+20.22 FAIRVIEW FARMS DRIVEWAY	-	10'-0"	10'-0"	
H4	320+40.01 FAIRVIEW FARMS DRIVEWAY	-	10'-0"	10'-0"	
H5	1107+63.72 DAVIS FIELD	-	8'-0"	8'-4"	
H6	216+60.31 BROADACRES FARM	118'-43"	10'-0"	6'-0"	

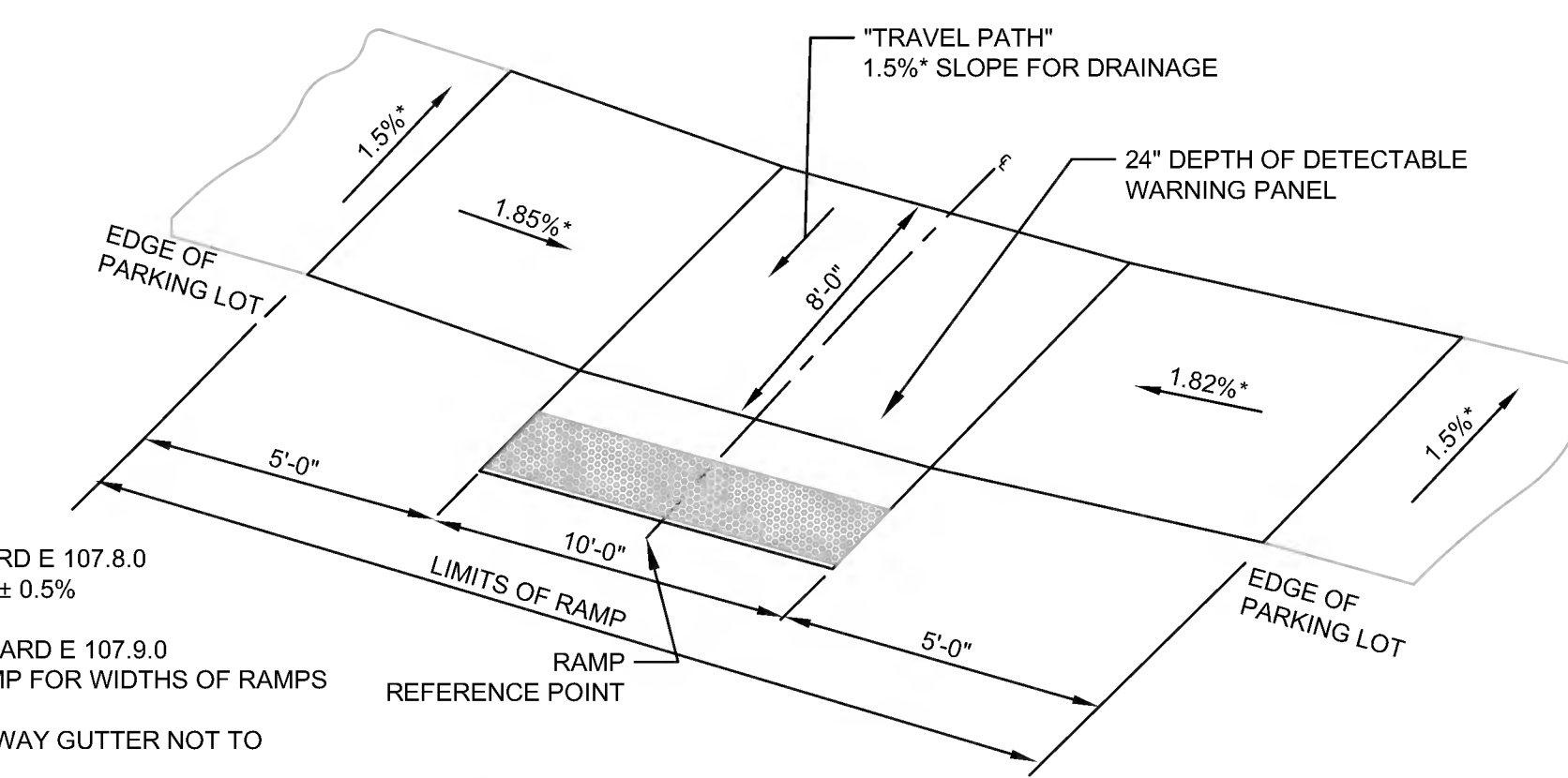

- NOTES:**
- SEE CONSTRUCTION STANDARD E 107.8.0
 - * CONSTRUCTION TOLERANCE ± 0.5%
 - ** SIDEWALK ENDS
 - *** SEE CONSTRUCTION STANDARD E 107.9.0
 - **** MAX. 4" HEIGHT OF DR. RAMP FOR WIDTHS OF RAMPS FROM 2'-4"
 - WCR CROSS SLOPE AT ROADWAY GUTTER NOT TO EXCEED 1.5%

**TYPE I WHEELCHAIR RAMP
SHARED-USE PATH ENTRANCE/EXIT AT DAVIS FIELD PARKING LOT**
N.T.S.

WCR#	DRIVEWAY REFERENCE POINT	STATION/ROADWAY	OFFSET
I-1	1105+91.63 DAVIS FIELD	4.00' LT	

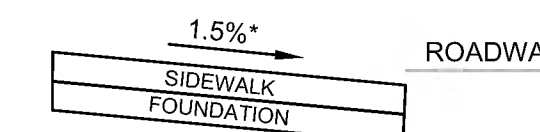

SUDBURY
BRUCE FREEMAN RAIL TRAIL OVER HOP BROOK

STATE	FED. AID PROJ. NO.	SHEET NO.	TOTAL SHEETS
MA	XXX-XXXX(XXX)X	223	319
PROJECT FILE NO.		608164	

KEY PLAN & PROFILE

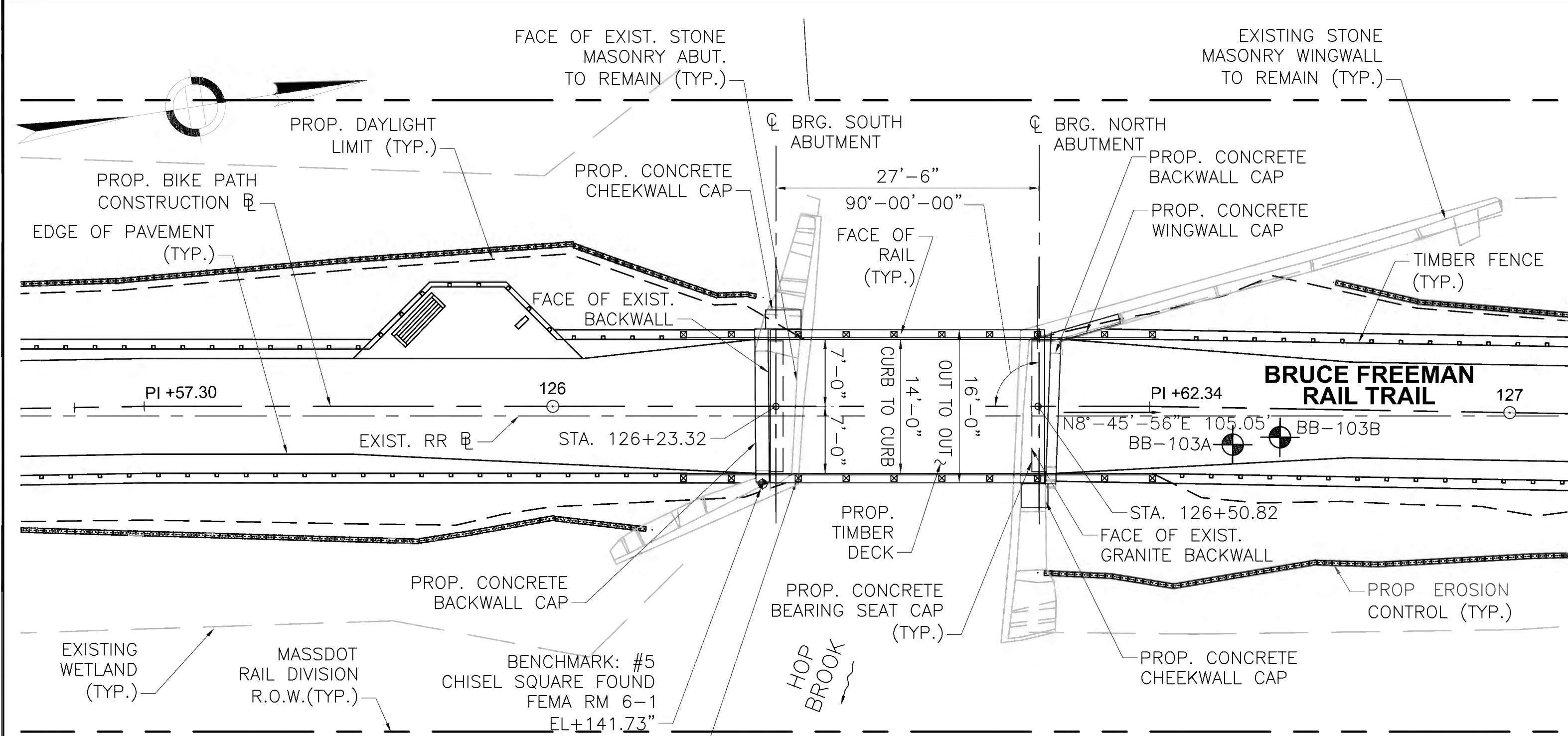

KEY PLAN
SCALE: 1" = 10'-0"

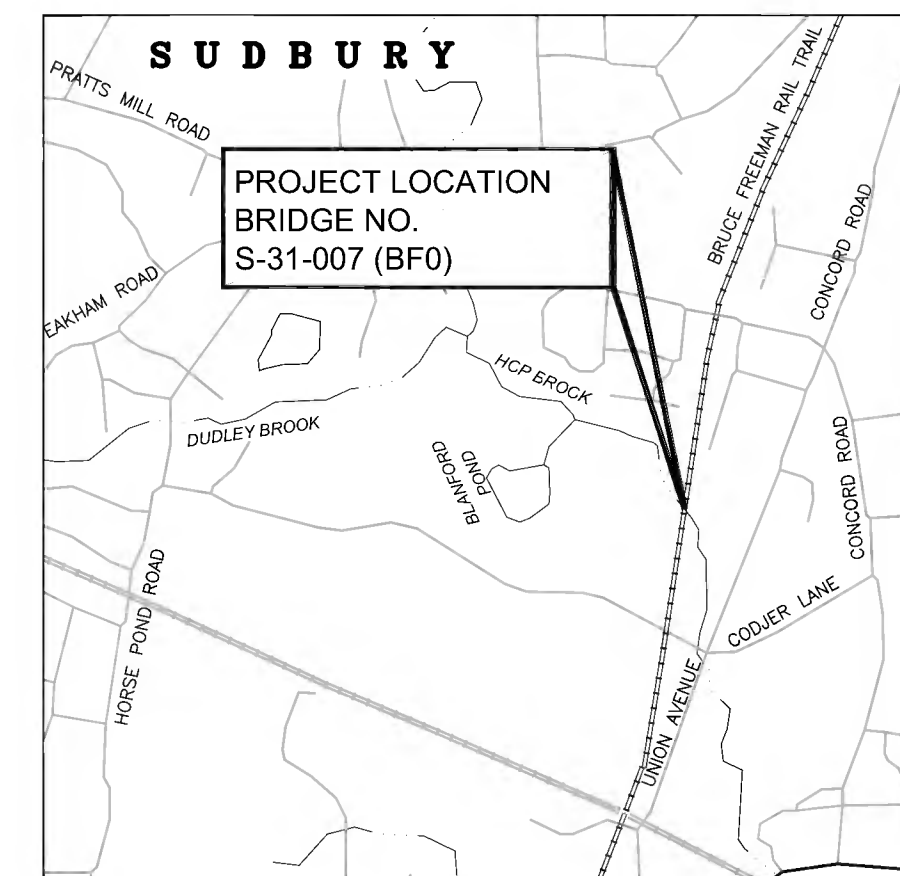

LOCUS PLAN
SCALE: 1" = 1200'

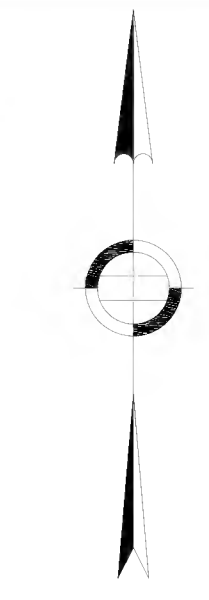

ESTIMATED QUANTITIES:
(NOT GUARANTEED)

ITEM NO.:	ITEM:	QUANTITY:
114.1	DEMOLITION OF SUPERSTRUCTURE OF BRIDGE NO. S-31-007	1 LS
127.1	REINFORCED CONCRETE EXCAVATION	3 CY
140.	BRIDGE EXCAVATION	5 CY
144.	CLASS B ROCK EXCAVATION	5 CY
151.2	GRAVEL BORROW FOR BACKFILLING STRUCTURES AND PIPES	2 CY
482.20	HOT POURED JOINT SEALER	29 FT
690.	STONE MASONRY WALL REMOVED AND REBUILT IN CEMENT MORTAR	6 CY
690.91	MASONRY REPOINTING	65 SY
991.1	CONTROL OF WATER - STRUCTURE NO. S-31-007	1 LS
995.	BRIDGE SUPERSTRUCTURE, BRIDGE NO. S-31-007	1 LS

INDEX

SHEET NO.	DESCRIPTION
1	KEY PLAN AND PROFILE
2	GENERAL NOTES
3	BORING LOGS
4	GENERAL PLAN AND ELEVATION
5	ABUTMENT REMOVAL PLANS AND ELEVATIONS
6	SOUTH ABUTMENT PLAN AND ELEVATION
7	NORTH ABUTMENT PLAN AND ELEVATION
8	SUBSTRUCTURE DETAILS
9	BEARING DETAILS
10	FRAMING PLAN AND STRUCTURAL STEEL DETAILS
11	DECK DETAILS AND TYPICAL SECTION
12	TIMBER BRIDGE RAIL DETAILS

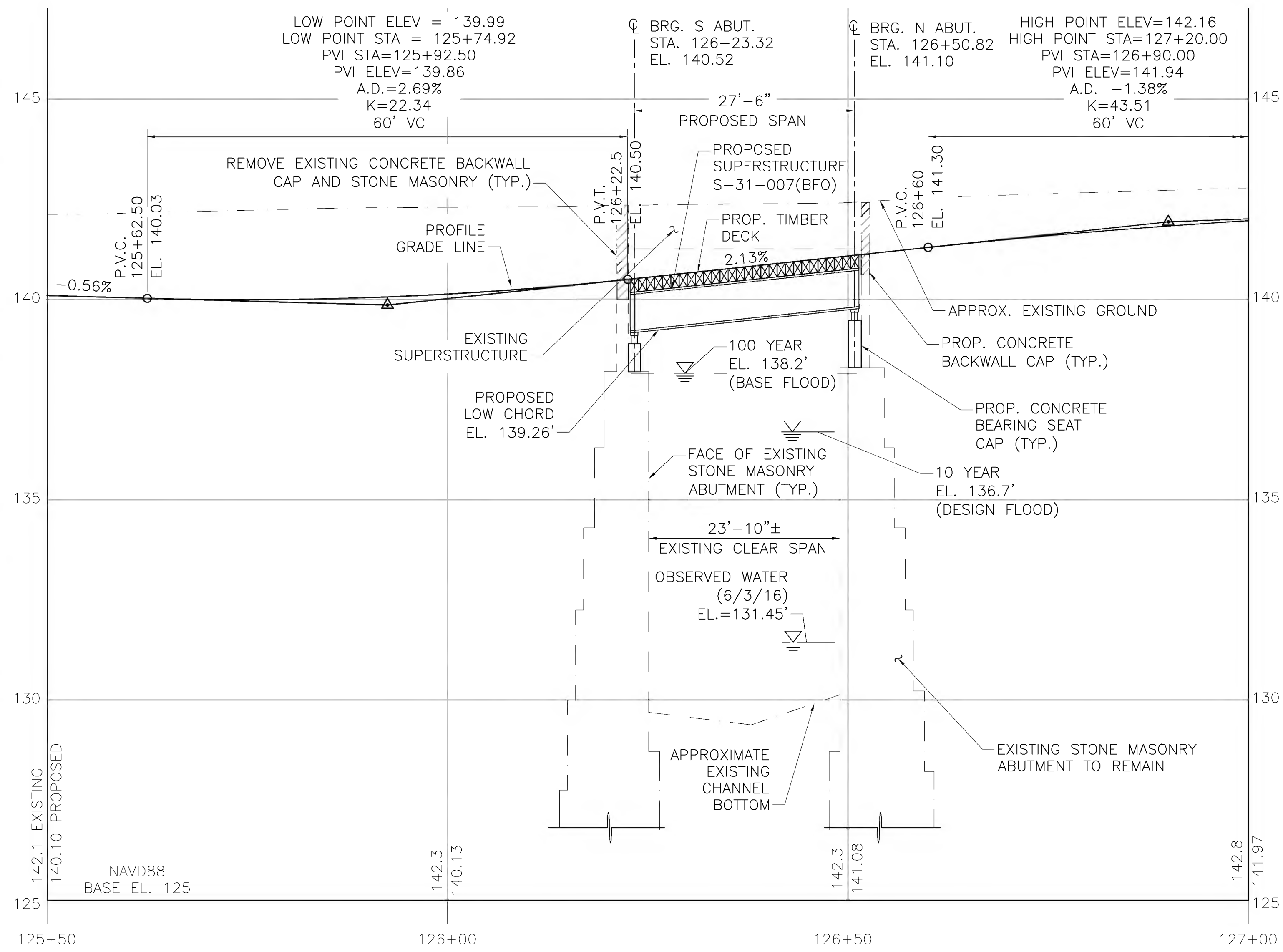

PROFILE ALONG BIKE PATH
HORIZONTAL SCALE: 1" = 10'-0"
VERTICAL SCALE: 1" = 2'-0"

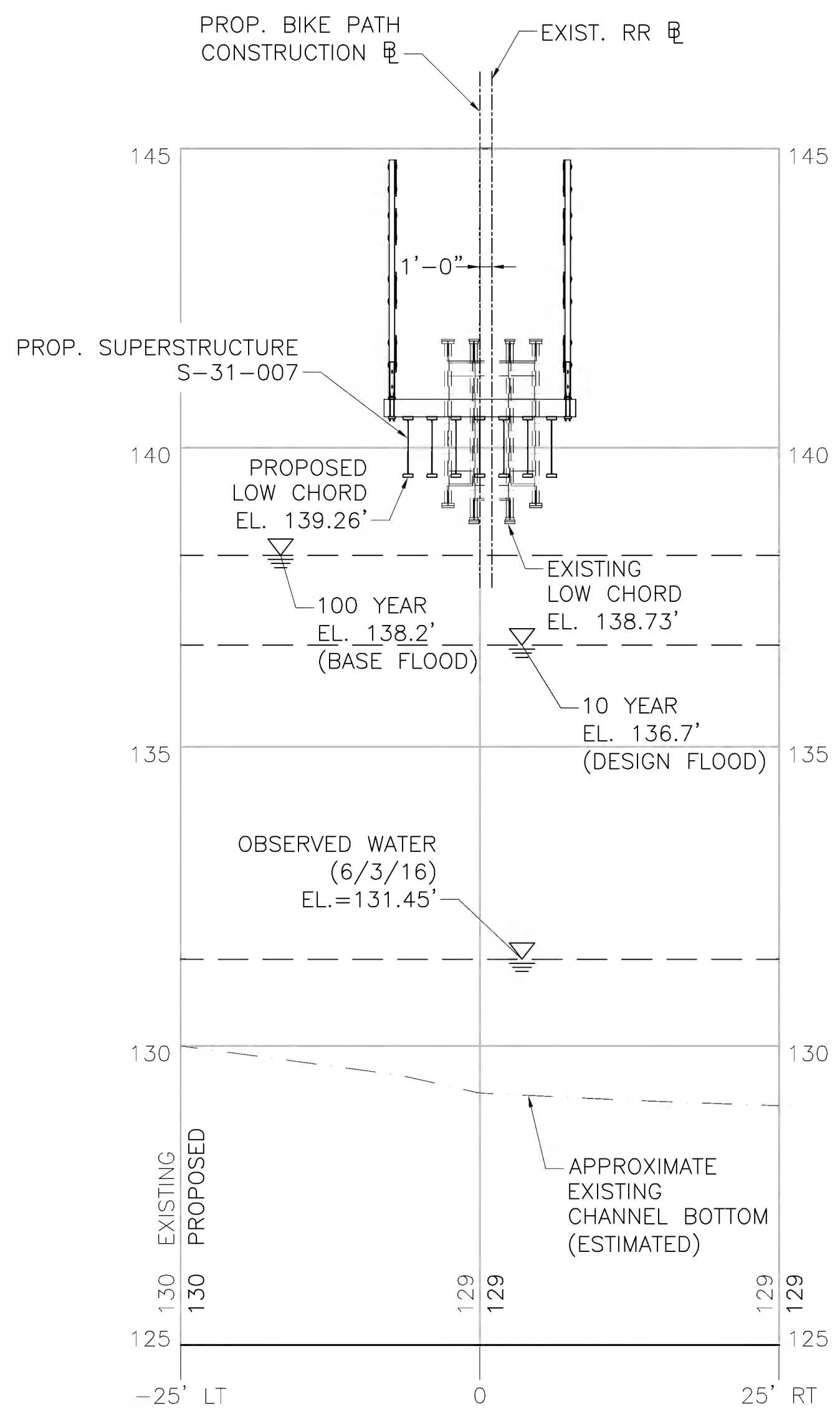

PROFILE ALONG HOP BROOK
HORIZONTAL SCALE: 1" = 10'-0"
VERTICAL SCALE: 1" = 2'-0"

P.E. STAMP SIGNATURE	MONTH DD, YYYY	ISSUED FOR CONSTRUCTION
	<p>PROPOSED SUPERSTRUCTURE REPLACEMENT SUDBURY BRUCE FREEMAN RAIL TRAIL OVER HOP BROOK</p>	
<p>FUSS & O'NEILL 1550 MAIN STREET, SUITE 400 SPRINGFIELD, MA 01103 413.452.0445 www.fando.com</p>	MASSACHUSETTS DEPARTMENT OF TRANSPORTATION HIGHWAY DIVISION 10 PARK PLAZA BOSTON, MASS	
	TITLE:	CHIEF ENGINEER

608164_BR(S-31-007)(FIRST SHEET).DWG Plotted on 18-Feb-2022 2:39 PM 2nd Structural Submittal (S2) 18-January-2022

**SUDBURY
BRUCE FREEMAN RAIL TRAIL OVER HOP BROOK**

STATE	FED. AID PROJ. NO.	SHEET NO.	TOTAL SHEETS
MA	XXX-XXXX(XXX)X	224	319
PROJECT FILE NO.		608164	

GENERAL NOTES

GENERAL NOTES:

DESIGN:

IN ACCORDANCE WITH THE 2020 AMERICAN ASSOCIATION OF STATE HIGHWAY AND TRANSPORTATION OFFICIALS LRFD BRIDGE DESIGN SPECIFICATIONS WITH CURRENT INTERIM SPECIFICATIONS THROUGH 2021 AND THE 2009 LRFD GUIDE SPECIFICATIONS FOR THE DESIGN OF PEDESTRIAN BRIDGES FOR H-10 VEHICULAR AND 90 PSF PEDESTRIAN LOADINGS.

MASSDOT BENCH MARK:

BM #5 CHISEL SQUARE FOUND
FEMA RM 6-1
ELEV. = 141.73'

ELEVATIONS ARE BASED ON THE NORTH AMERICAN VERTICAL DATUM (NAVD) OF 1988.

DATE:

TO BE PLACED ON THE FACE OF THE NORTHEAST AND SOUTHWEST PROPOSED CONCRETE CHEEKWALL CAPS. A DETAIL SHOWING SIZE AND CHARACTER OF NUMERALS WILL BE FURNISHED. THE DATE USED SHALL BE THE LATEST YEAR OF CONTRACT COMPLETION AS OF THE DATE THE FIRST CONCRETE CHEEKWALL CAP IS CONSTRUCTED. BOTH CONCRETE CHEEKWALL CAPS SHALL FEATURE THE SAME DATE.

SURVEY NOTEBOOKS:

SURVEY PERFORMED BY VANASSE HANGEN BRUSTLIN, INC FIELD NOTEBOOKS SHALL BE OBTAINED FROM FUSS AND O'NEILL, INC. SPRINGFIELD, MA.

SCALES:

SCALES NOTED ON THE PLANS ARE NOT APPLICABLE TO REDUCED SIZE PRINTS. DIVIDE SCALES BY 2 FOR HALF-SIZE PRINTS (A3).

UNSUITABLE MATERIAL:

ALL UNSUITABLE MATERIAL SHALL BE REMOVED WITHIN THE LIMITS OF THE OF THE PROPOSED STRUCTURE, AS DIRECTED BY THE ENGINEER.

DIMENSIONS:

ALL DIMENSIONS SHOWN ON PLANS ARE FOR STRUCTURES AT 68° F, UNLESS OTHERWISE NOTED.

EXISTING CONSTRUCTION:

DIMENSIONS SHOWN ARE TAKEN FROM SURVEY, VARIOUS FIELD MEASUREMENTS, AND GEOTECHNICAL EXPLORATION AND ARE NOT GUARANTEED. THE CONTRACTOR SHALL DETERMINE AND ESTABLISH ALL DIMENSIONS AND DETAILS NECESSARY FOR COMPLETION OF ALL WORK BY FIELD MEASUREMENT AND SURVEY. THE CONTRACTOR SHALL BE RESPONSIBLE AND NOT ORDER ANY MATERIAL OR COMMENCE ANY FABRICATION UNTIL HE HAS MADE THE REQUIRED MEASUREMENTS ON THE ACTUAL STRUCTURE AND THE EXTENT OF THE PROPOSED WORK HAS BEEN APPROVED BY THE ENGINEER. EXISTING BRIDGE PLANS ARE NOT AVAILABLE FOR REFERENCE.

TIMBER:

ALL STRUCTURAL TIMBER FOR DECKING SHALL BE PRESSURE TREATED MIXED SOUTHERN PINE GRADE 1 OR APPROVED EQUAL.

CONCRETE:

4,000 PSI, 3/4 INCH, 610 CEMENT CONCRETE SHALL BE PROVIDED FOR THE BEARING SEATS, WINGWALL CAPS, BACKWALL RESTORATION, AND CHEEK WALLS.

4,000 PSI 1 1/2 INCH, 565 CEMENT CONCRETE SHALL BE PROVIDED FOR CONCRETE ENCASEMENT OF THE FIRST RAIL POST OFF THE BRIDGE IF MINIMUM EMBEDMENT OF POST CANNOT BE MET.

REINFORCEMENT:

REINFORCING STEEL SHALL CONFORM TO THE REQUIREMENTS OF AASHTO M 31 GRADE 60. UNLESS OTHERWISE NOTED ON THE CONSTRUCTION DRAWINGS, ALL BARS SHALL BE LAPPED AS FOLLOWS:

MODIFICATION CONDITION	#4 BARS	#5 BARS	#6 BARS
1. NONE	16"	19"	23"
2. 12" OF CONCRETE BELOW BAR	20"	25"	30"
3. EPOXY COATED BARS, COVER < 3d _b , OR CLEAR SPACING < 6d _b	23"	29"	34"
4. COATED BARS, ALL OTHER CASES	18"	23"	27"
5. CONDITION 2. AND 3.	26"	32"	39"
6. CONDITION 2. AND 4.	24"	30"	36"

ALL OTHER BARS SHOULD BE LAPPED AS SHOWN ON THE CONSTRUCTION DRAWINGS.

ALL REINFORCEMENT IN CONCRETE BACKWALL, BEARING SEAT, CHEEKWALL, AND WINGWALL CAPS SHALL BE EPOXY COATED.

SECTION MARK:

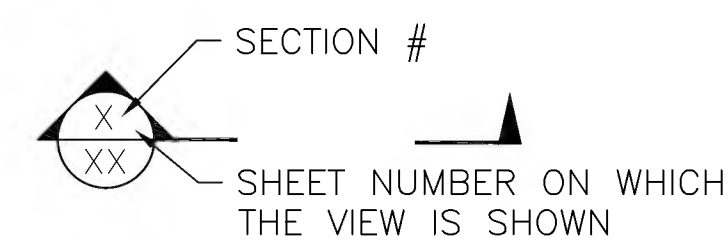

TRAFFIC DATA		
	ROADWAY OVER	ROADWAY UNDER
DESIGN YEAR	N/A	
AVERAGE DAILY TRAFFIC - PRESENT	N/A	
AVERAGE DAILY TRAFFIC - DESIGN YEAR	N/A	
DESIGN HOURLY VOLUME	N/A	
DIRECTIONAL DISTRIBUTION	N/A	
TRUCK PERCENTAGE - AVERAGE DAY	N/A	
TRUCK PERCENTAGE - PEAK HOUR	N/A	
DESIGN SPEED	18 MPH	
DIRECTIONAL DESIGN HOURLY VOLUME	N/A	

SEISMIC DESIGN CRITERIA	
DESIGN RETURN PERIOD:	1,000
DESIGN SPECTRA	
As	0.11
SDs	0.23
SD1	0.09
SITE CLASS	D
SEISMIC DESIGN CATEGORY (SDC)	A

HYDRAULIC DESIGN DATA	
DRAINAGE AREA (SQ. MILES)	14.7
DESIGN FLOOD DISCHARGE (C.F.S.)	452
DESIGN FLOOD FREQUENCY (YEARS)	10
DESIGN FLOOD VELOCITY (F.P.S.)	2.66
DESIGN FLOOD ELEVATION (FEET, NAVD)	136.7

BASE (100-YEAR) FLOOD DATA	
BASE FLOOD DISCHARGE (C.F.S.)	881
BASE FLOOD ELEVATION (FEET, NAVD)	138.2

DESIGN AND CHECK SCOUR DATA	
DESIGN SCOUR FLOOD EVENT RETURN FREQUENCY (YEARS)	25
DESIGN FLOOD ABUTMENT SCOUR DEPTH (FEET)	N/A
DESIGN FLOOD PIER SCOUR DEPTH (FEET)	N/A
CHECK SCOUR FLOOD EVENT RETURN FREQUENCY (YEARS)	50
CHECK FLOOD ABUTMENT SCOUR DEPTH (FEET)	N/A
CHECK FLOOD PIER SCOUR DEPTH (FEET)	N/A

FLOOD OF RECORD	
DISCHARGE (C.F.S.)	N/A
FREQUENCY (IF KNOWN, YEARS)	N/A
MAXIMUM ELEVATION (FEET, NAVD)	N/A
DATE (MM/YYYY)	N/A
HISTORY OF ICE FLOES	N/A
EVIDENCE OF SCOUR AND EROSION	N/A

MONTH DD, YYYY	ISSUED FOR CONSTRUCTION
DATE	DESCRIPTION
USE ONLY PRINTS OF LATEST DATE	

**SUDBURY
BRUCE FREEMAN RAIL TRAIL OVER HOP BROOK**

STATE	FED. AID PROJ. NO.	SHEET NO.	TOTAL SHEETS
MA	XXX-XXXX(XXX)X	225	319
PROJECT FILE NO.		608164	

BORING LOGS

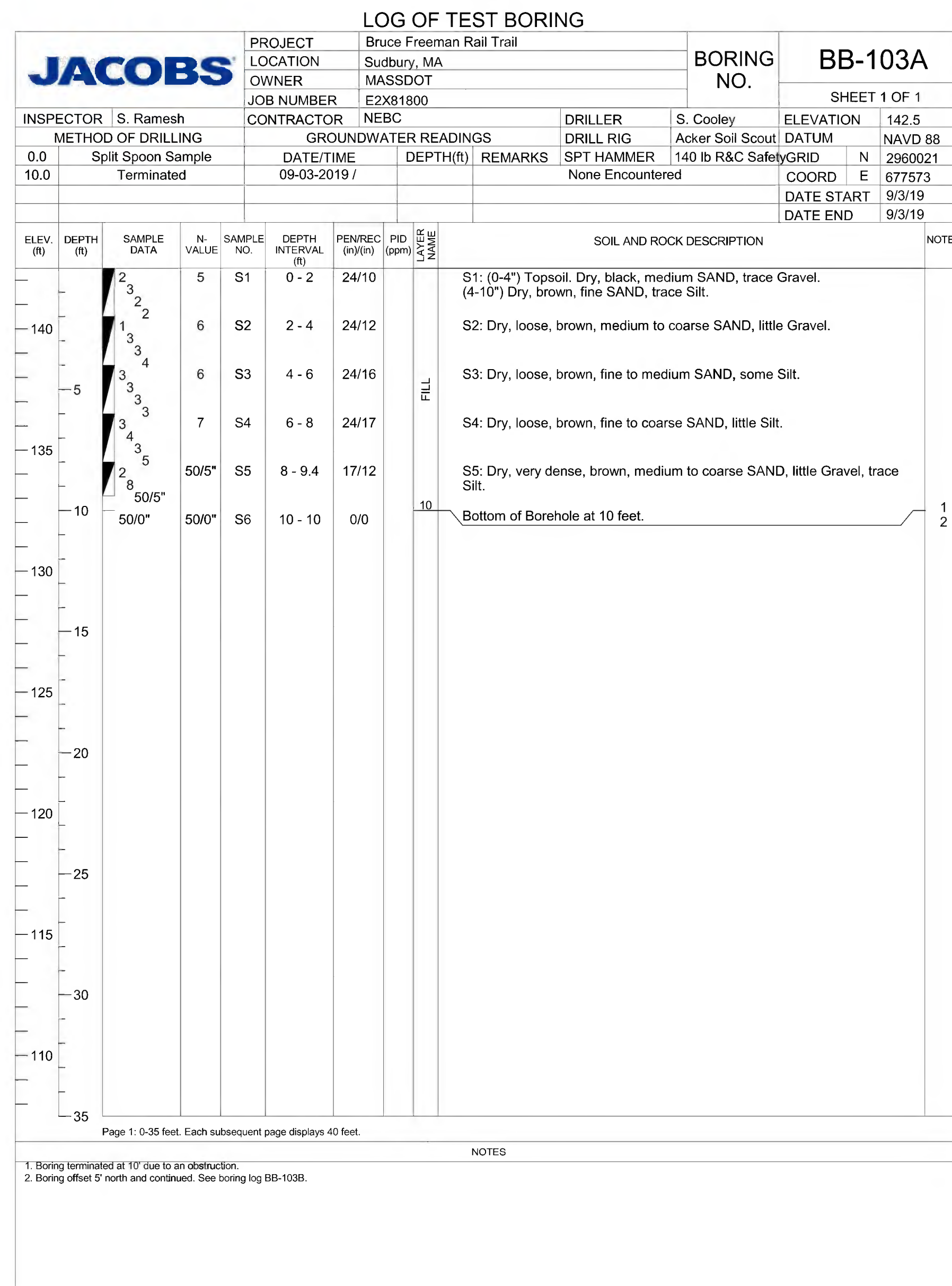

▽ 133.1

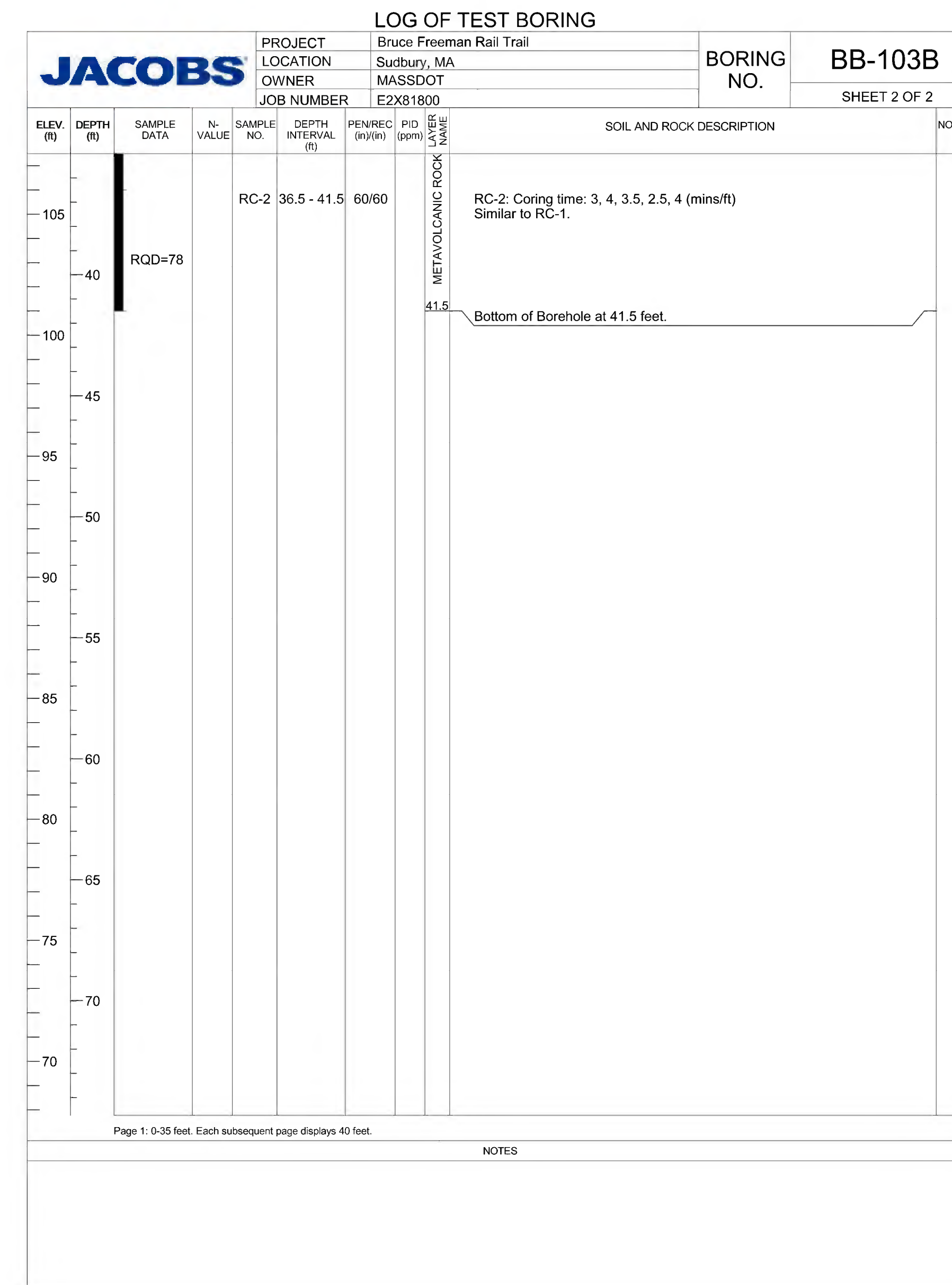
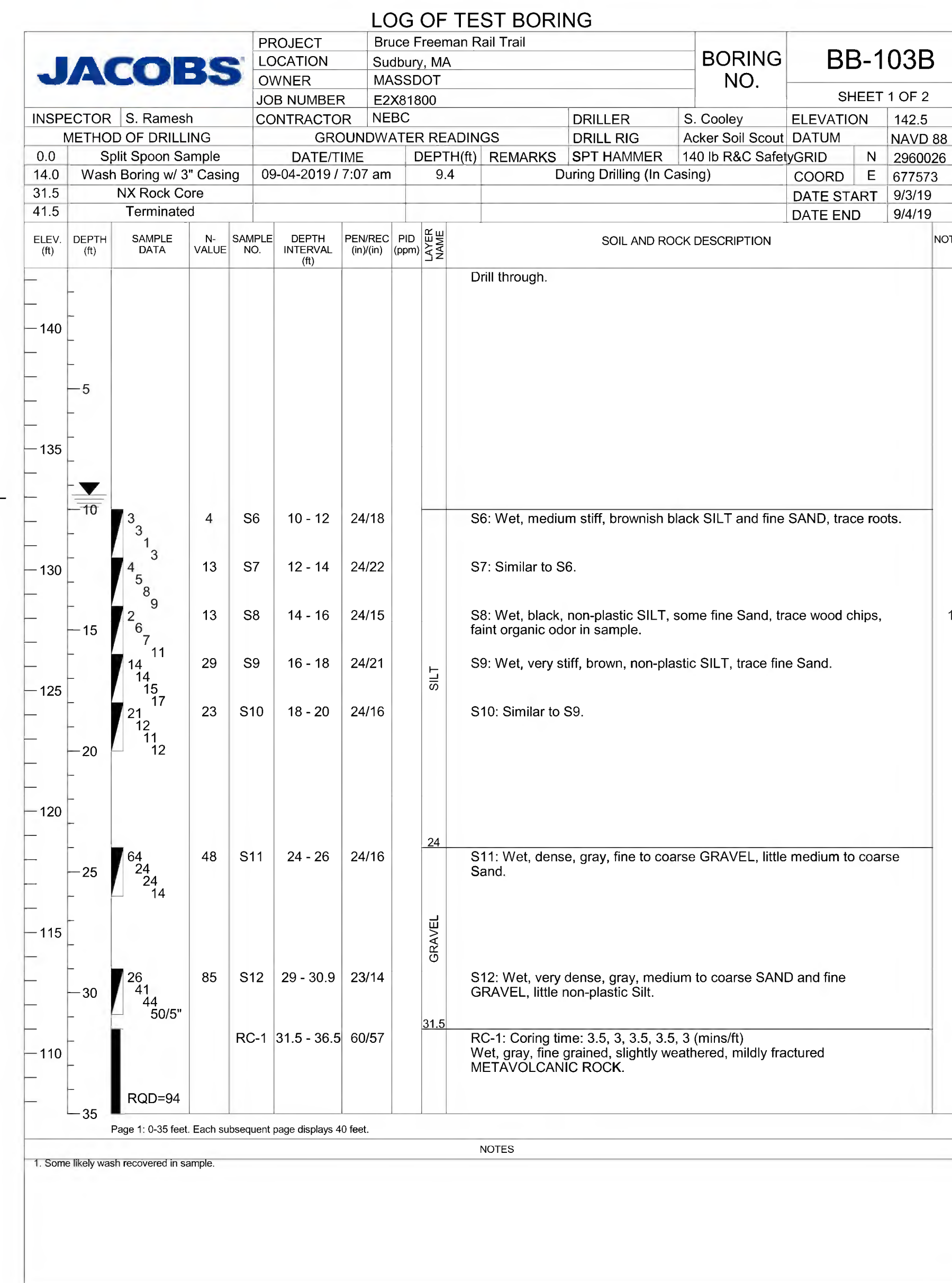

BORING NOTES:

- LOCATION OF BORINGS SHOWN ON THE PLANS THUS: BB-#
- BORINGS ARE TAKEN FOR PURPOSE OF DESIGN AND SHOW CONDITIONS AT BORING POINTS ONLY, BUT DO NOT NECESSARILY SHOW THE NATURE OF THE MATERIALS TO BE ENCOUNTERED DURING CONSTRUCTION.
- WATER LEVELS SHOWN ON THE BORING LOGS WERE OBSERVED AT THE TIME OF TAKING BORINGS AND DO NOT NECESSARILY SHOW THE TRUE GROUND WATER LEVEL.
- FIGURES IN COLUMNS INDICATE NUMBER OF BLOWS REQUIRED TO DRIVE A 1 1/8" I.D. SPLIT SPOON SAMPLER 6" USING A 140 POUND WEIGHT FALLING 30".
- BORING SAMPLES ARE STORED AT A STORAGE FACILITY LOCATED ON ROUTE 114 (219 WINTHRUP AVE.) IN LAWRENCE, MA. THE CONTRACTOR MAY EXAMINE THE SOIL AND ROCK SAMPLES BY CONTACTING THE MASSDOT GEOTECHNICAL SECTION AT 10 PARK PLAZA, BOSTON, MA.
- ALL BORINGS WERE MADE IN SEPTEMBER 2019.
- BORINGS WERE MADE BY NEW ENGLAND BORING CONTRACTOR, INC., P.O. BOX 165, DERRY, NH 03038.
- THE NORTH AMERICAN VERTICAL DATUM (NAVD) OF 1988 IS USED THROUGHOUT.

MONTH DD, YYYY	ISSUED FOR CONSTRUCTION
DATE	DESCRIPTION
USE ONLY PRINTS OF LATEST DATE	

608164_BRS(S-31-007)(BORINGS).DWG Plotted on 18-Feb-2022 2:40 PM 2nd Structural Submittal (S2) 18-January-2022

**SUDBURY
BRUCE FREEMAN RAIL TRAIL OVER HOP BROOK**

STATE	FED. AID PROJ. NO.	SHEET NO.	TOTAL SHEETS
MA	XXX-XXXX(XXX)X	226	319
PROJECT FILE NO.		608164	

GENERAL PLAN & ELEVATION

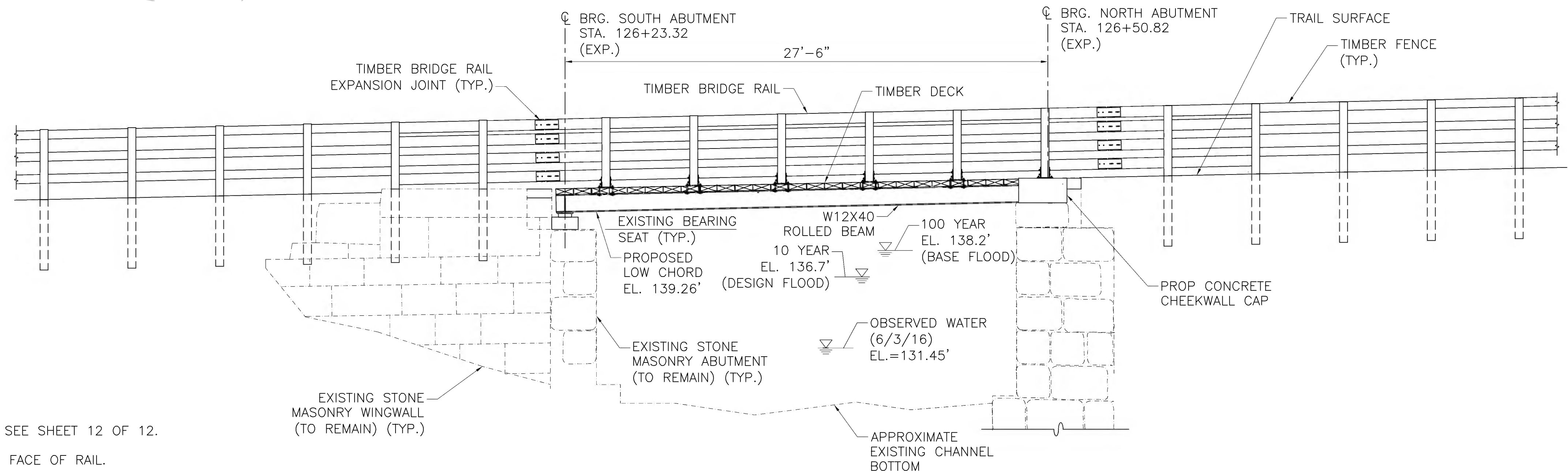
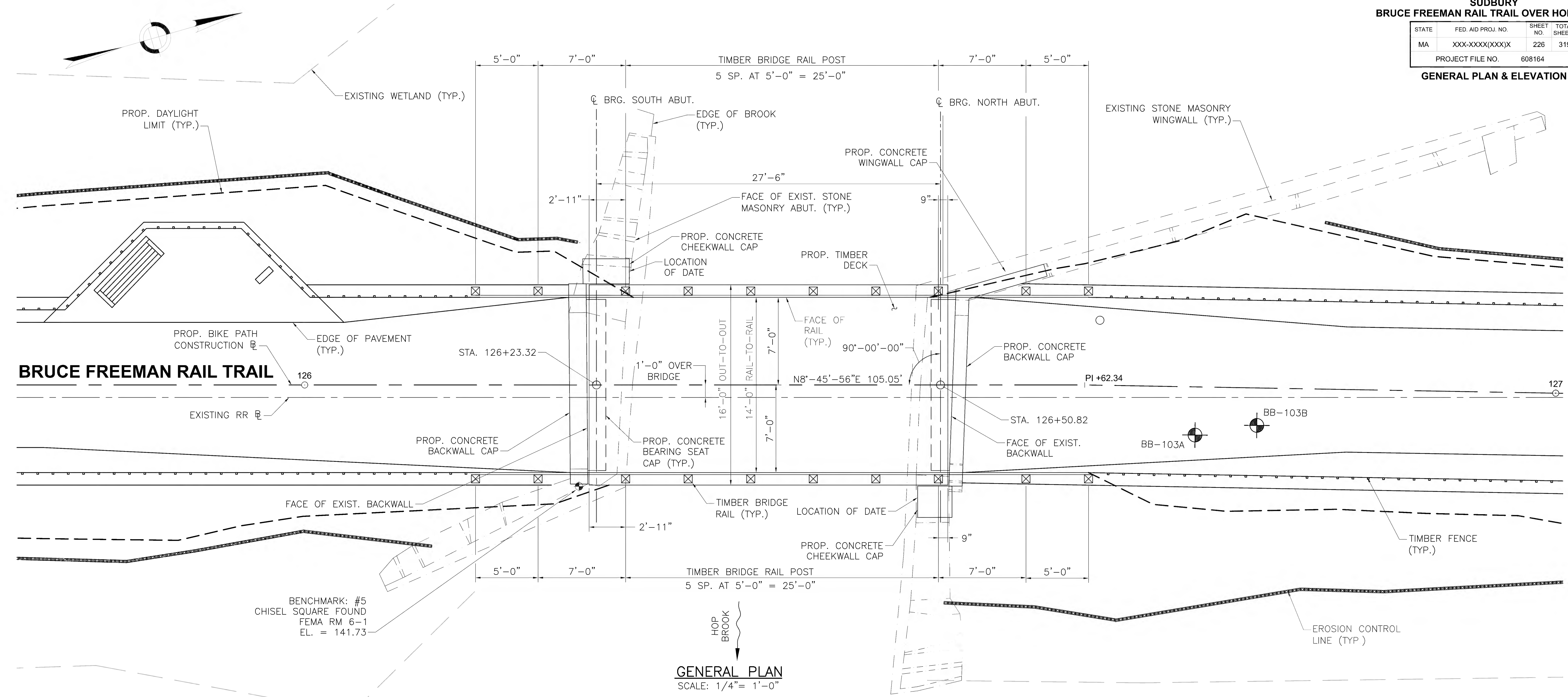

- NOTES:**
- FOR TIMBER BRIDGE RAIL DETAILS, SEE SHEET 12 OF 12.
 - RAIL POSTS ARE MEASURED ALONG FACE OF RAIL.

NOTE:
DECK END PLATE NOT SHOWN FOR CLARITY.
SEE SHEET 11 FOR PLATE DETAILS.

MONTH DD, YYYY	ISSUED FOR CONSTRUCTION
DATE	DESCRIPTION
USE ONLY PRINTS OF LATEST DATE	

608164_BRF(S-31-007)GENPLAN.DWG Plotted on 18-Feb-2022 2:40 PM 2nd Structural Submittal (S2) 18-January-2022

STATE	FED. AID PROJ. NO.	SHEET NO.	TOTAL SHEETS
MA	XXX-XXXX(XXX)X	227	319
PROJECT FILE NO.		608164	

**ABUTMENT REMOVAL
PLANS & ELEVATIONS**

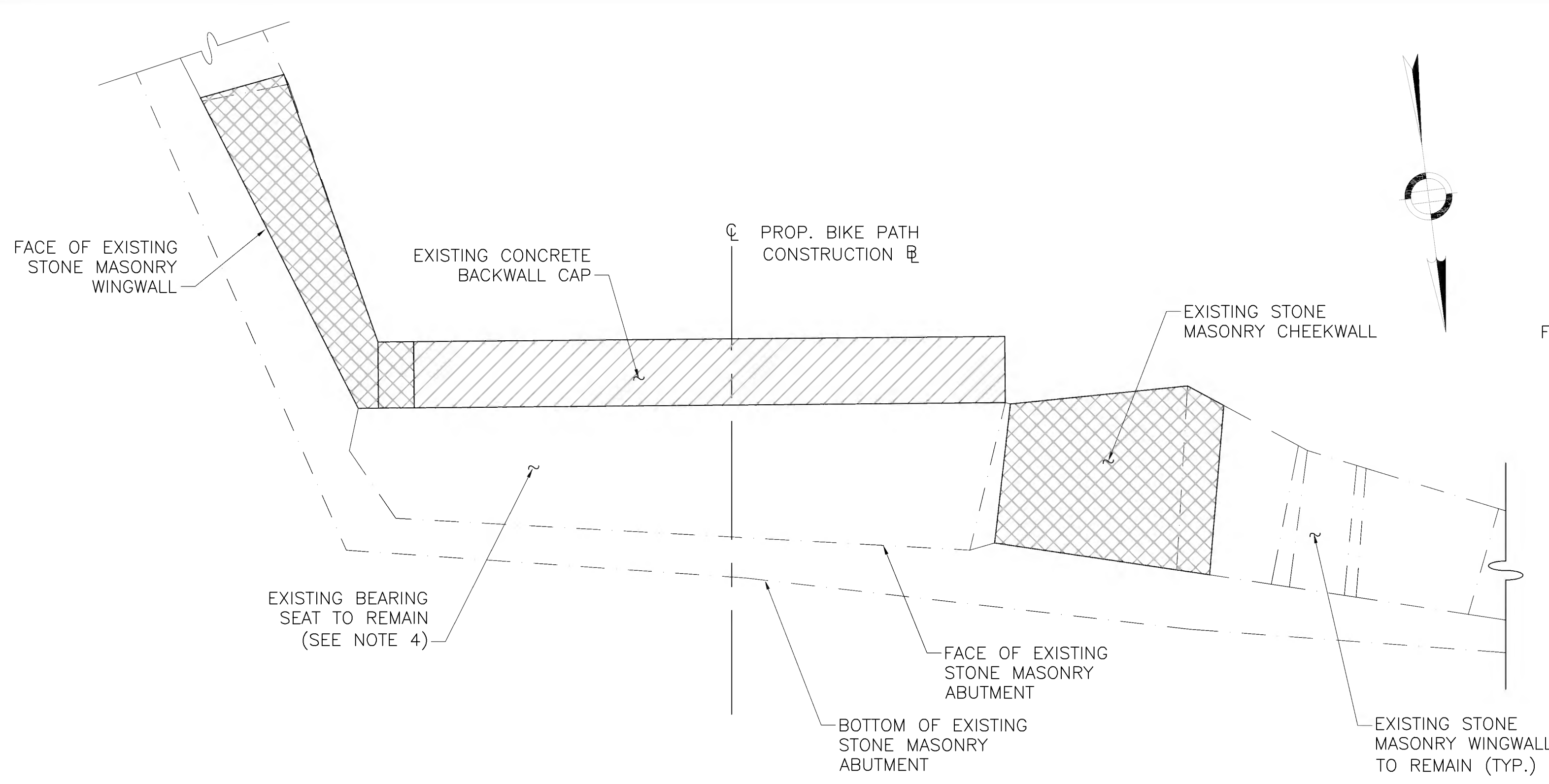

SOUTH ABUTMENT REMOVAL PLAN
SCALE: 1/2"=1'-0"

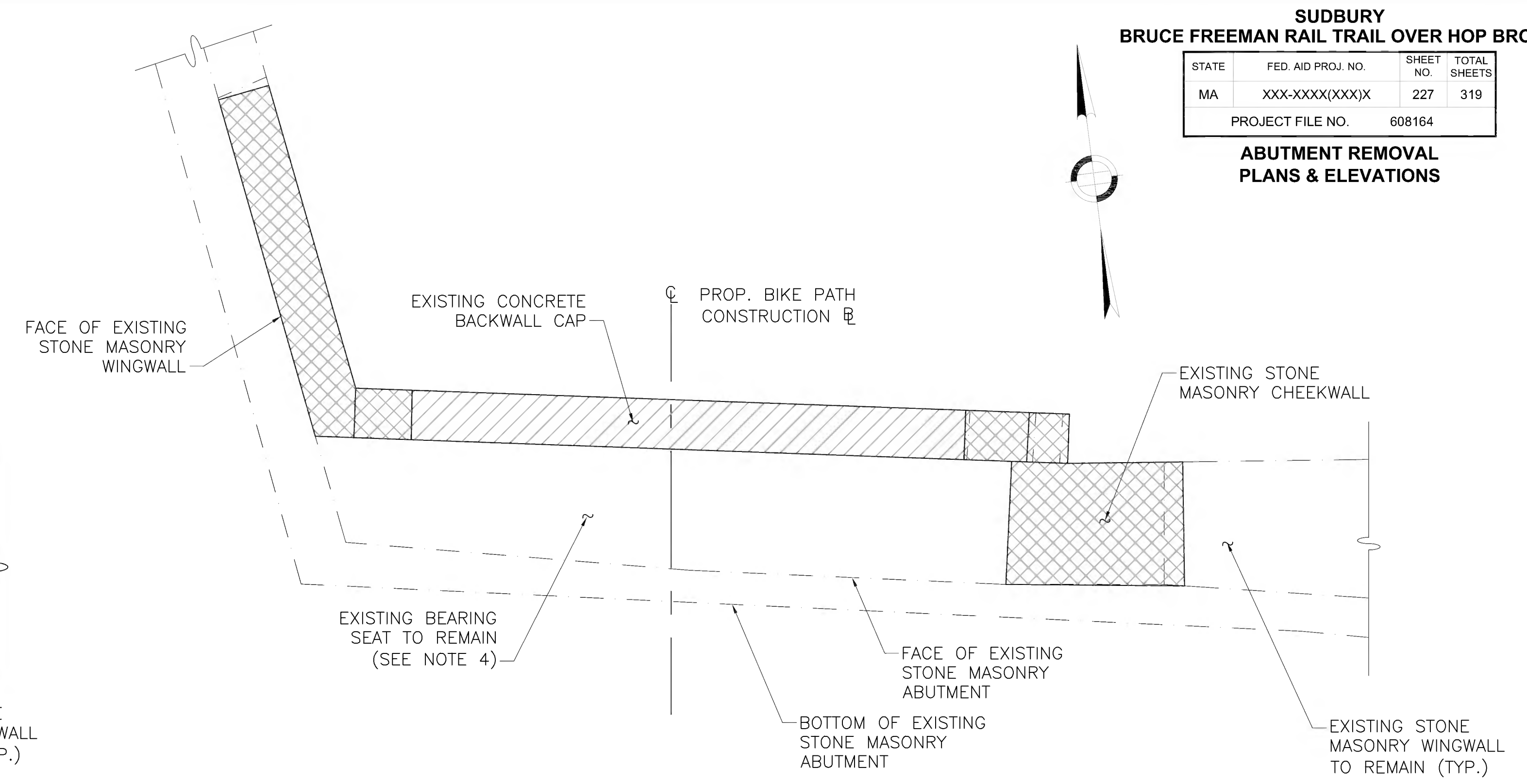

NORTH ABUTMENT REMOVAL PLAN
SCALE: 1/2"=1'-0"

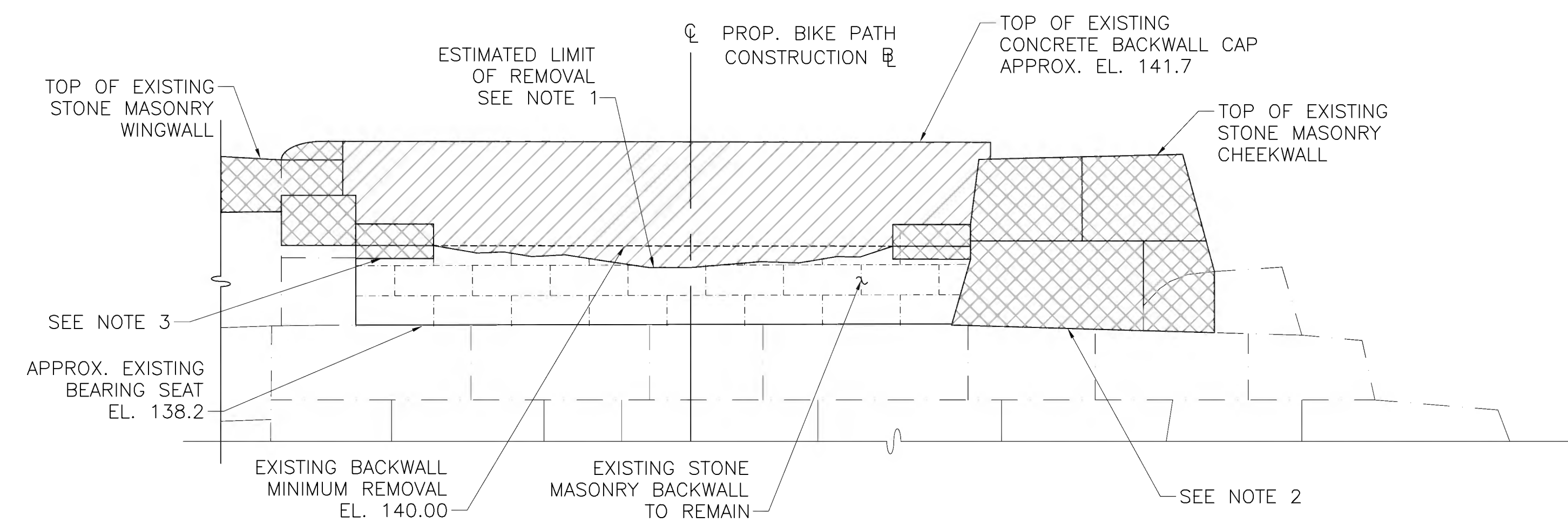

SOUTH ABUTMENT AND SOUTHWEST WINGWALL REMOVAL ELEVATION
SCALE: 1/2"=1'-0"

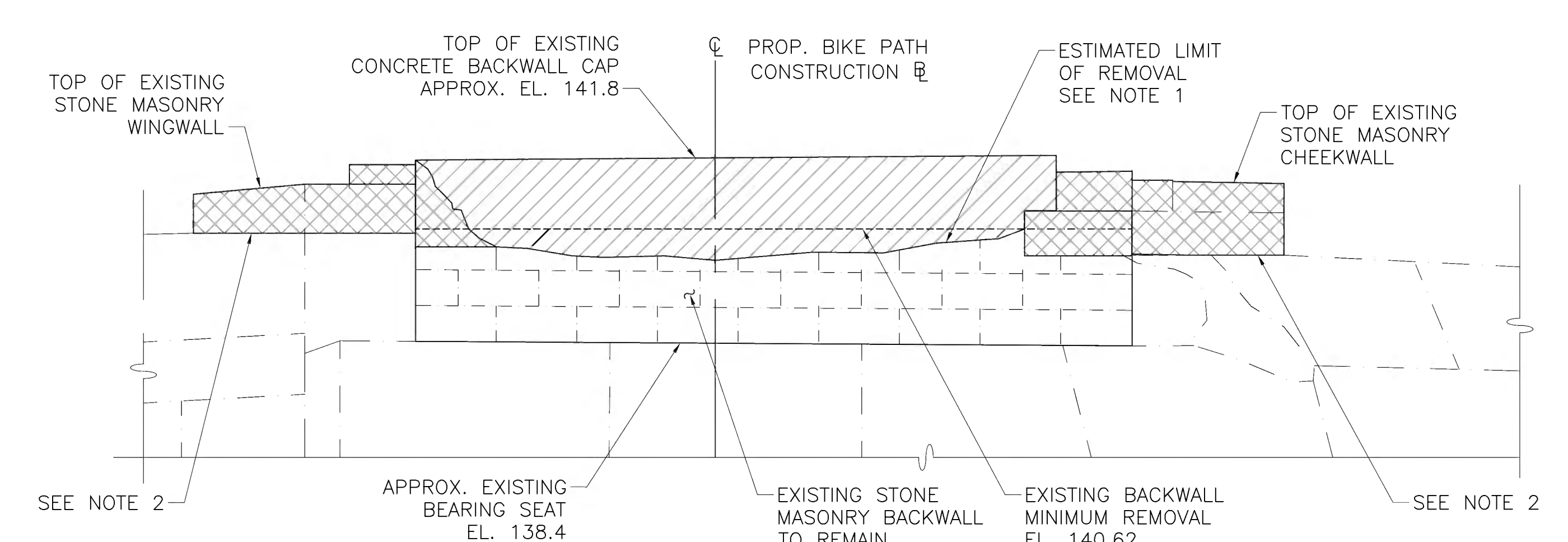

NORTH ABUTMENT AND NORTHEAST WINGWALL REMOVAL ELEVATION
SCALE: 1/2"=1'-0"

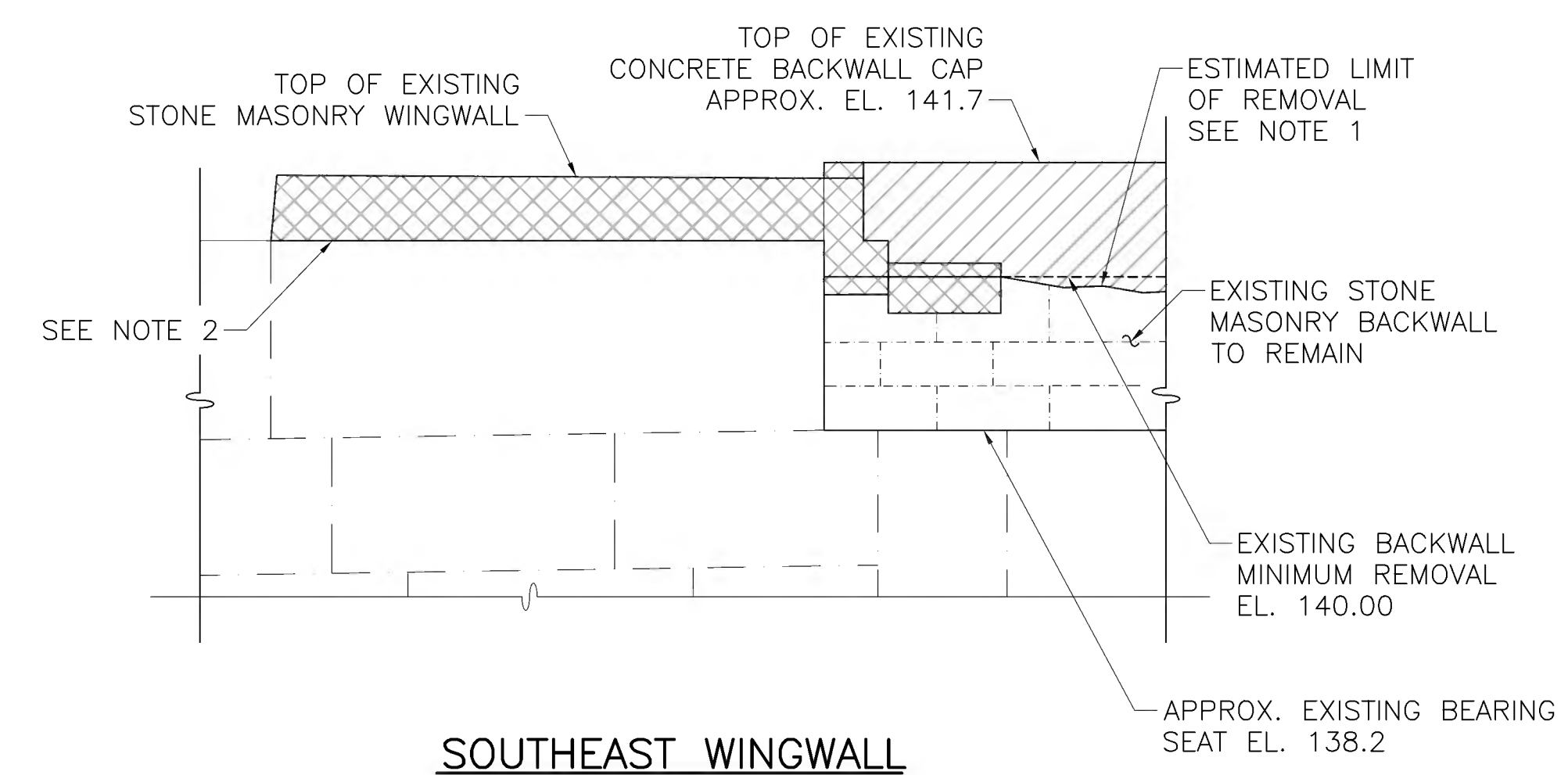

**SOUTHEAST WINGWALL
REMOVAL ELEVATION**
SCALE: 1/2"=1'-0"

EXISTING SUBSTRUCTURE REMOVAL NOTES:

1. BOTTOM OF EXISTING CONCRETE BACKWALL CAP VARIES. REMOVAL LIMITS SHALL EXTEND TO AT LEAST THE MINIMUM REMOVAL ELEVATION AS SHOWN ON THIS SHEET. FINAL REMOVAL LIMITS SHALL BE DETERMINED BY THE ENGINEER. PAYMENT FOR EXISTING CONCRETE BACKWALL REMOVAL SHALL BE INCLUDED IN ITEM 127.1, "REINFORCED CONCRETE EXCAVATION".
2. FINAL EXISTING STONE MASONRY CHEEKWALL AND WINGWALL REMOVAL LIMITS SHALL BE DETERMINED BY THE ENGINEER. PAYMENT FOR EXISTING STONE MASONRY REMOVAL, INCLUDING STONE MASONRY PORTIONS OF THE EXISTING ABUTMENT BACKWALLS, SHALL BE INCLUDED UNDER ITEM 144, "CLASS B ROCK EXCAVATION".
3. WHEN THE HORIZONTAL JOINT IN THE STONE FALLS BELOW THE MINIMUM REMOVAL ELEVATION, THE STONES OR PORTIONS OF STONES SHALL BE REMOVED BY MECHANICAL METHODS. WITH APPROVAL OF THE ENGINEER, THE ENTIRE STONE SHALL BE REMOVED AND REPLACED WITH 4,000 PSI, 3/4 INCH, 610 CEMENT CONCRETE IN LIEU OF MECHANICAL METHODS.
4. THE EXISTING ABUTMENT BEARING SEATS SHALL BE BLAST CLEANED OF EFFLORESCENCE AND DEBRIS AS DIRECTED BY THE ENGINEER. PAYMENT SHALL BE INCIDENTAL TO ITEM 995.

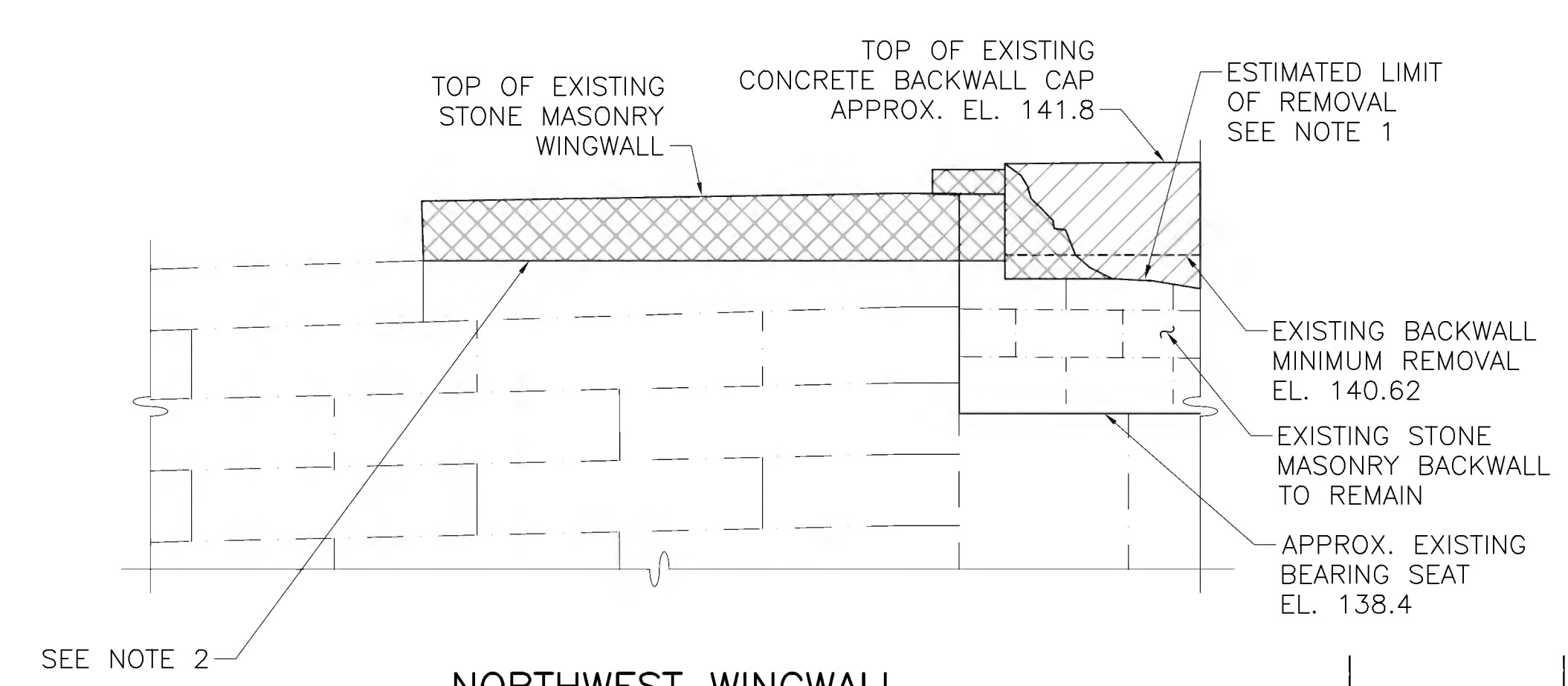

**NORTHWEST WINGWALL
REMOVAL ELEVATION**
SCALE: 1/2"=1'-0"

LEGEND

	CONCRETE REMOVAL LIMITS
	MASONRY REMOVAL LIMITS

MONTH DD, YYYY	ISSUED FOR CONSTRUCTION
DATE	DESCRIPTION
USE ONLY PRINTS OF LATEST DATE	

2nd Structural Submittal (S2) 18-January-2022
608164_BRG(S-31-007)REMOVAL.DWG
Plotted on 18-Feb-2022 2:40 PM

STATE	FED. AID PROJ. NO.	SHEET NO.	TOTAL SHEETS
MA	XXX-XXXX(XXX)X	228	319
PROJECT FILE NO.		608164	

SOUTH ABUTMENT PLAN & ELEVATION

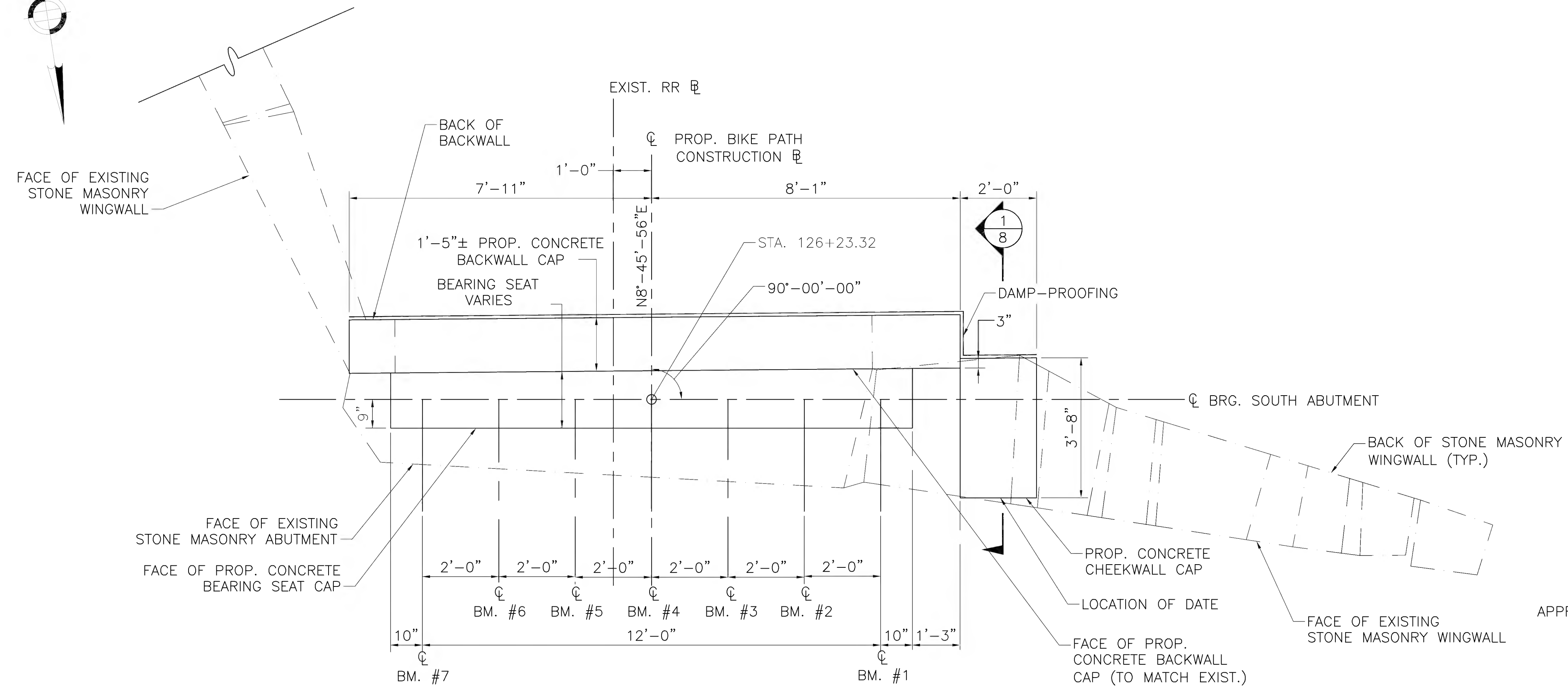
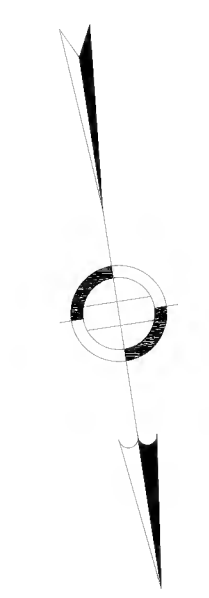

SOUTH ABUTMENT PLAN
SCALE: 1/2"=1'-0"

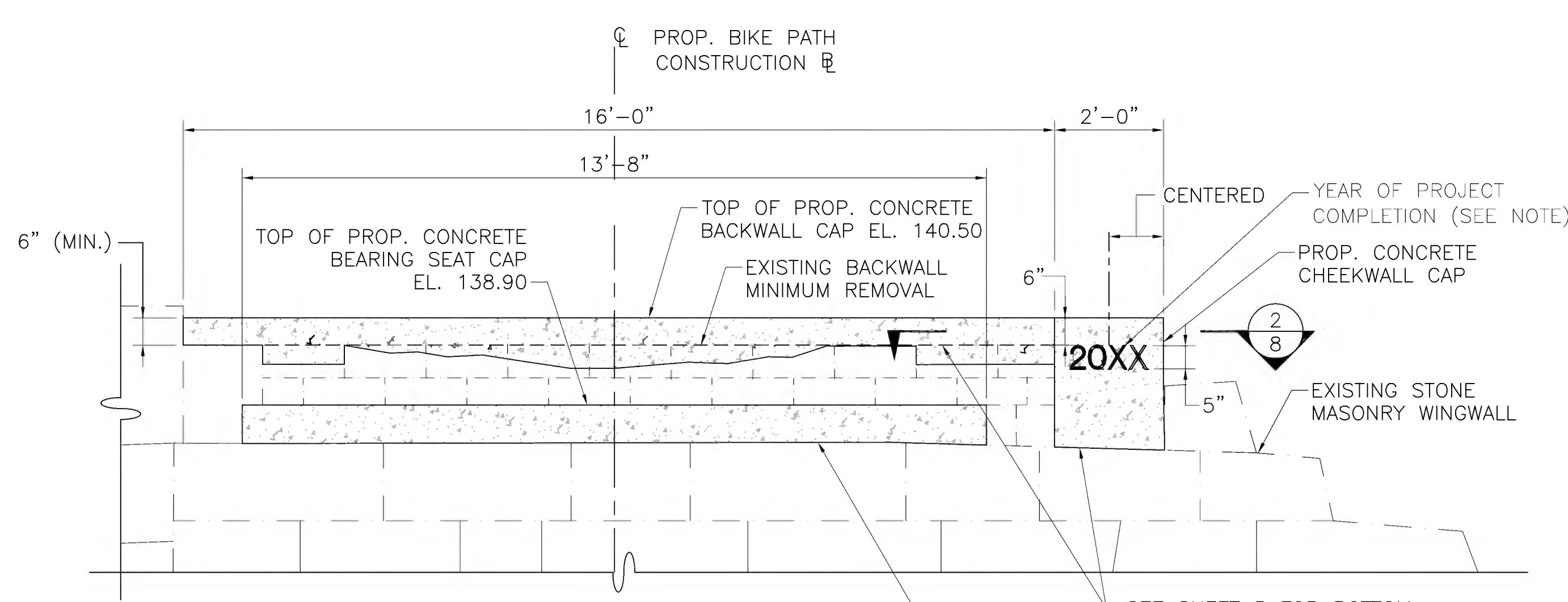

SOUTH ABUTMENT AND SOUTHWEST WINGWALL ELEVATION
SCALE: 1/2"=1'-0"

NOTE:
USE LATEST CONTRACT COMPLETION YEAR IN EFFECT WHEN THE FIRST CONCRETE CHEEKWALL CAP IS CAST. USE THE YEAR FOR BOTH CONCRETE CHEEKWALL CAPS.

NOTES:

1. BEARING SEAT ELEVATION IS GIVEN AT \odot BEARING.
2. BACKWALL ELEVATION IS GIVEN AT FACE OF BACKWALL.
3. SEE SHEET 8 FOR EXISTING ABUTMENT REPAIR NOTES.
4. SEE SHEET 8 FOR REINFORCING IN PROPOSED CHEEKWALL CAPS.
5. USE APPROVED NON-SHRINK GROUT WITH MINIMUM COMPRESSIVE STRENGTH F'_c OF 6,200 PSI. SEE SPECIAL PROVISIONS FOR ADDITIONAL REQUIREMENTS UNDER ITEM 995.
6. ALL CONCRETE SHALL BE 4000 PSI, 3/4 INCH, 610 CEMENT CONCRETE.

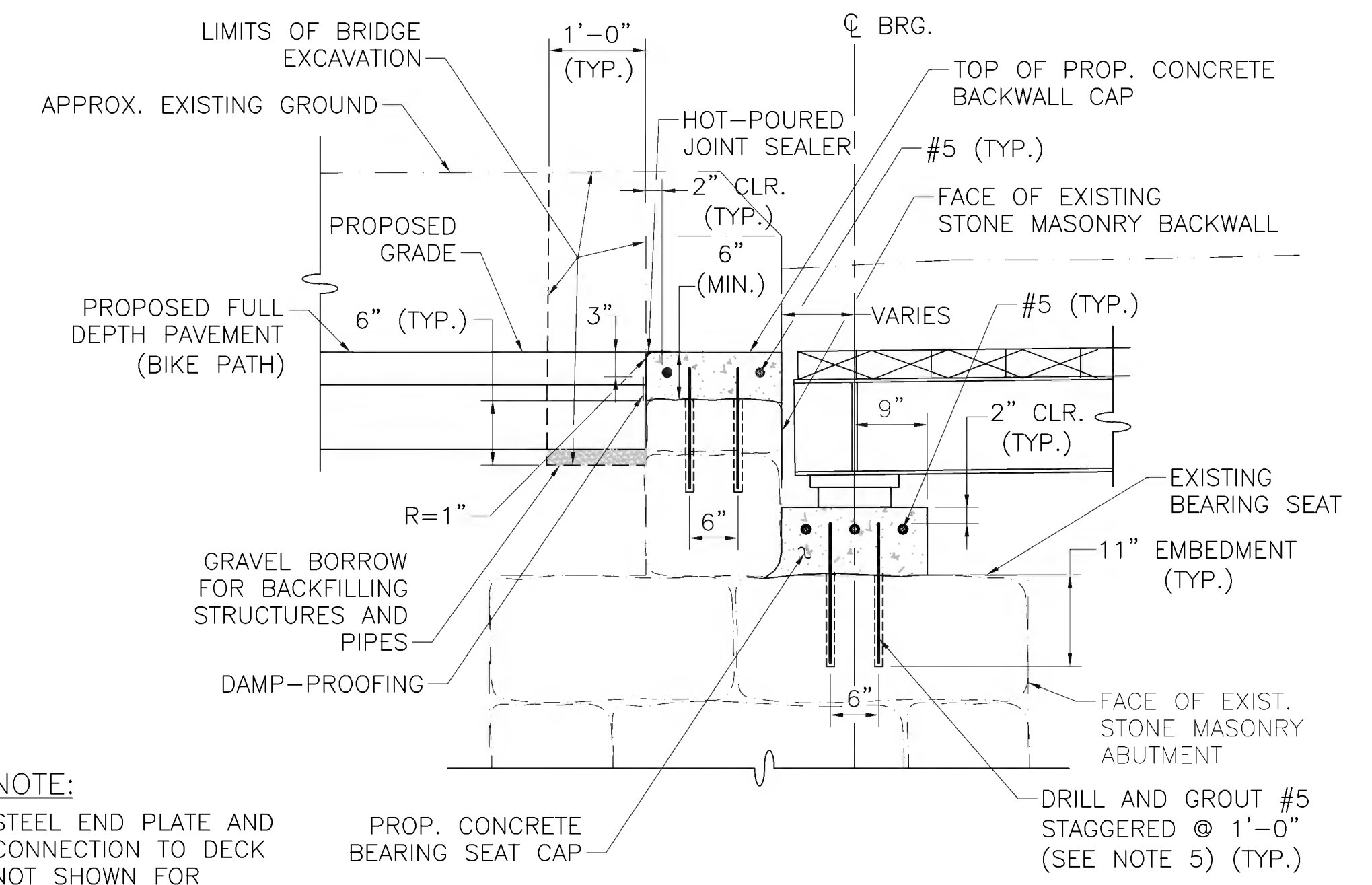

TYPICAL ABUTMENT SECTION
SCALE: 3/4"=1'-0"

NOTE:
STEEL END PLATE AND CONNECTION TO DECK NOT SHOWN FOR CLARITY. SEE SHEET 11.

MONTH DD, YYYY	ISSUED FOR CONSTRUCTION
DATE	DESCRIPTION
USE ONLY PRINTS OF LATEST DATE	

608164_BRT(S-31-007)(SOUTH ABUT).DWG Potted on 18-Feb-2022 2:41 PM 2nd Structural Submittal (S2) 18-January-2022

STATE	FED. AID PROJ. NO.	SHEET NO.	TOTAL SHEETS
MA	XXX-XXXX(XXX)X	229	319
PROJECT FILE NO.		608164	

NORTH ABUTMENT PLAN & ELEVATION

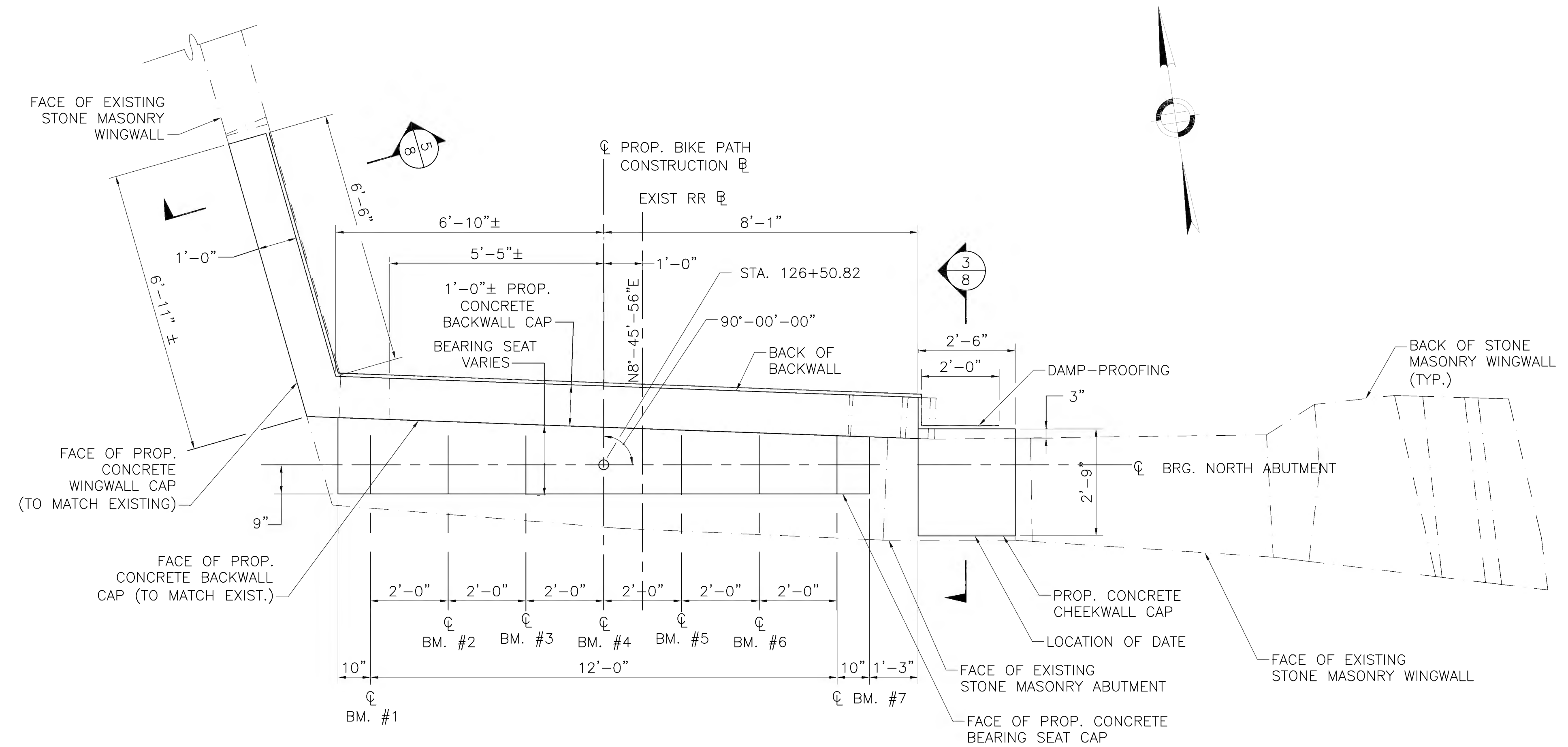

NORTH ABUTMENT PLAN
SCALE: 1/2"=1'-0"

NOTES:

1. BEARING SEAT ELEVATION IS GIVEN AT ϕ BEARING.
2. BACKWALL ELEVATION IS GIVEN AT FACE OF BACKWALL.
3. SEE SHEET 8 FOR EXISTING ABUTMENT REPAIR NOTES.
4. SEE SHEET 8 FOR REINFORCING IN PROPOSED CHEEKWALL CAPS
5. USE APPROVED NON-SHRINK GROUT WITH MINIMUM COMPRESSIVE STRENGTH F'_c OF 6,200 PSI. SEE SPECIAL PROVISIONS FOR ADDITIONAL REQUIREMENTS UNDER ITEM 995.
6. SEE SHEET 6 FOR TYPICAL ABUTMENT SECTION.
7. ALL CONCRETE SHALL BE 4000 PSI, $\frac{3}{4}$ INCH, 610 CEMENT CONCRETE.

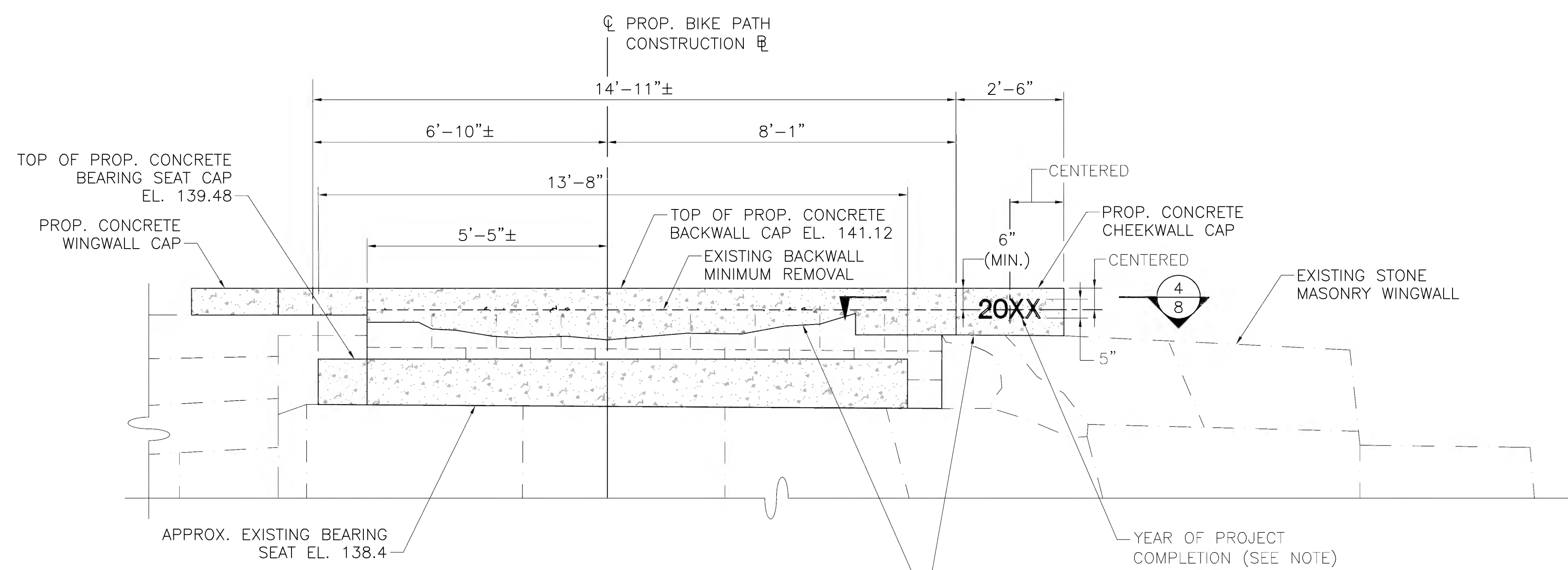

**NORTH ABUTMENT AND
NORTHEAST WINGWALL ELEVATION**
SCALE: 1/2"=1'-0"

NOTE:
USE LATEST CONTRACT COMPLETION YEAR IN EFFECT WHEN THE FIRST CONCRETE CHEEKWALL CAP IS CAST. USE THIS YEAR FOR BOTH CONCRETE CHEEKWALL CAPS.

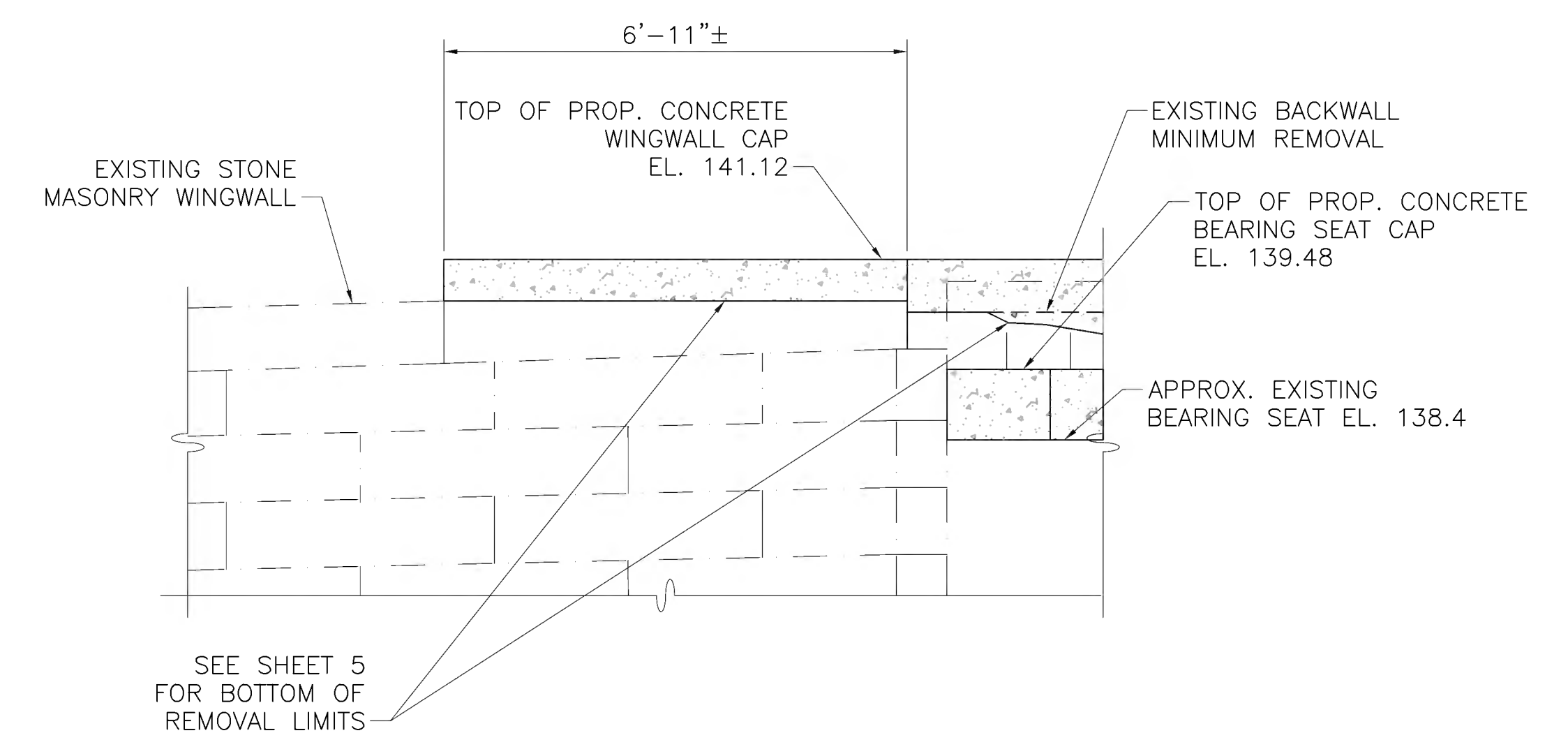

NORTHWEST WINGWALL ELEVATION
SCALE: 1/2"=1'-0"

MONTH DD, YYYY	ISSUED FOR CONSTRUCTION
DATE	DESCRIPTION
USE ONLY PRINTS OF LATEST DATE	

608164_BRES(S-31-007)(NORTH ABUT).DWG Plotted on 18-Feb-2022 2:41 PM 2nd Structural Submittal (S2) 18-January-2022

STATE	FED. AID PROJ. NO.	SHEET NO.	TOTAL SHEETS
MA	XXX-XXX(XXX)X	230	319
PROJECT FILE NO.		608164	

SUBSTRUCTURE DETAILS

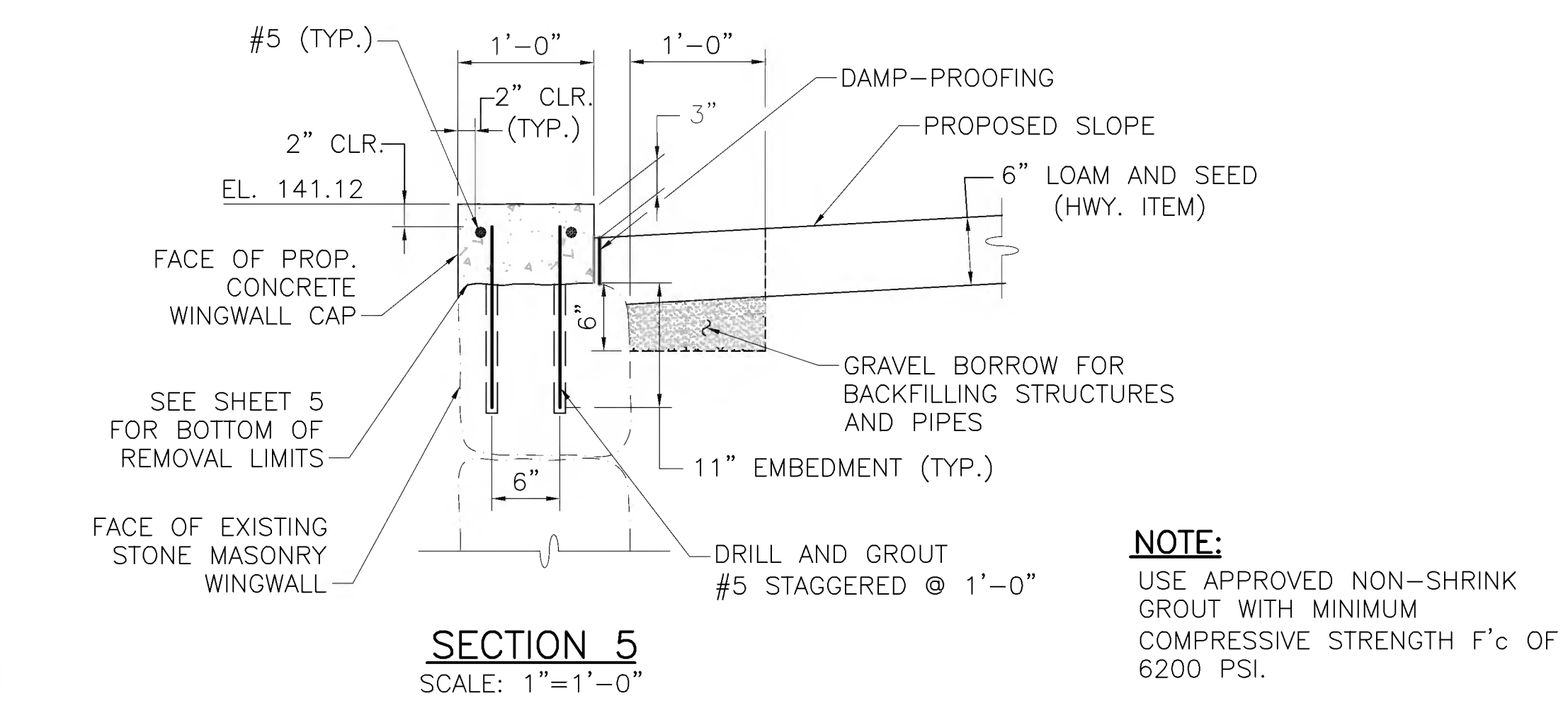
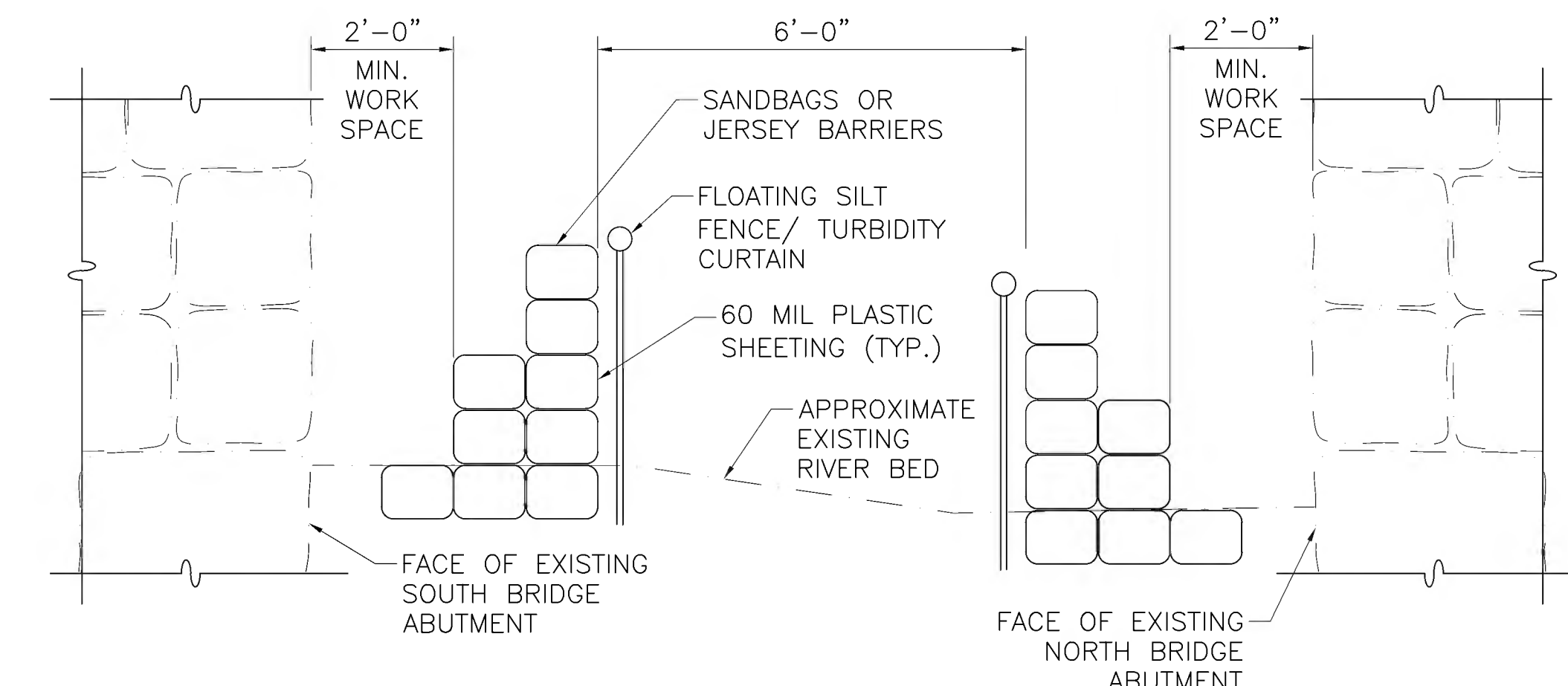
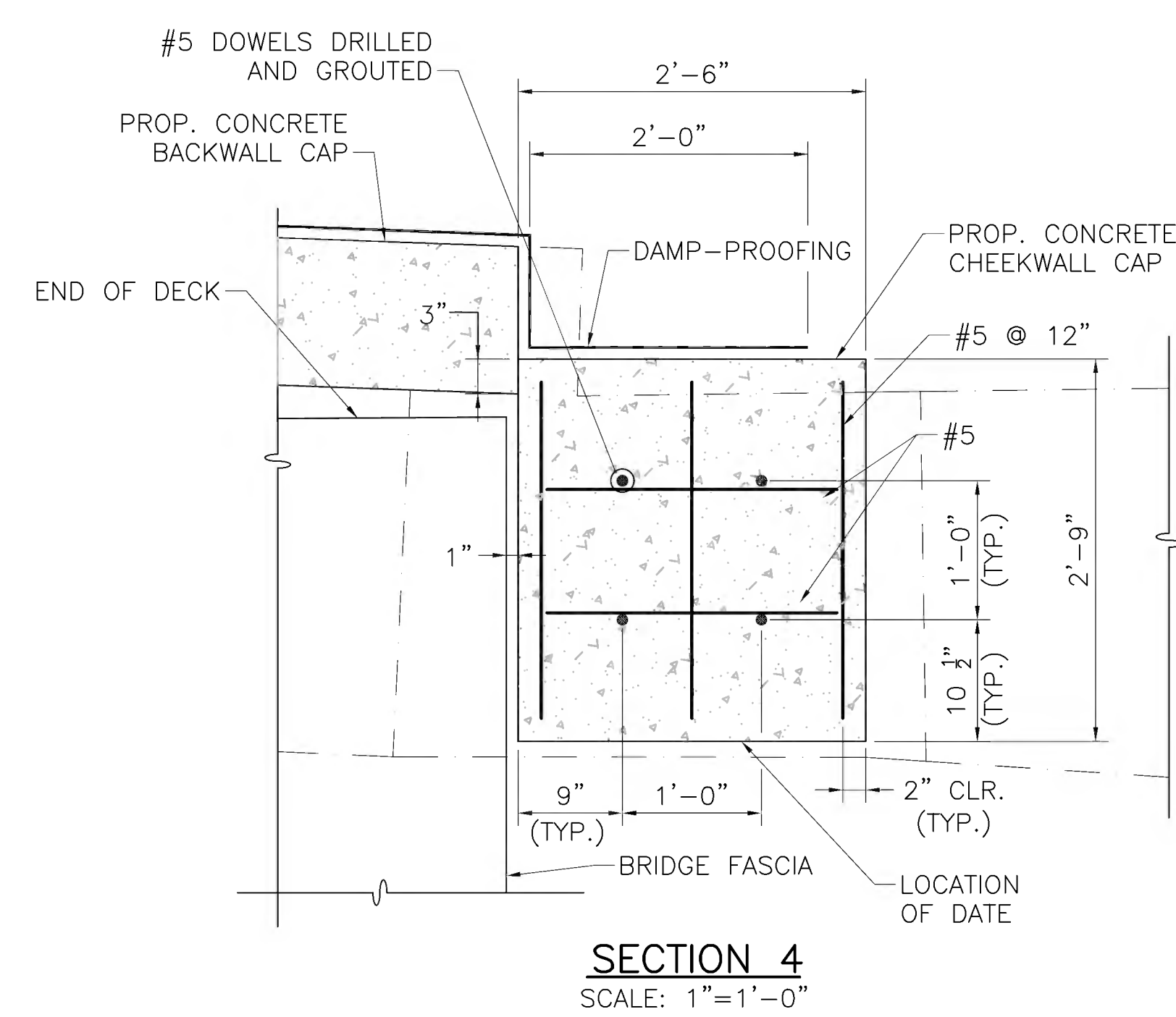
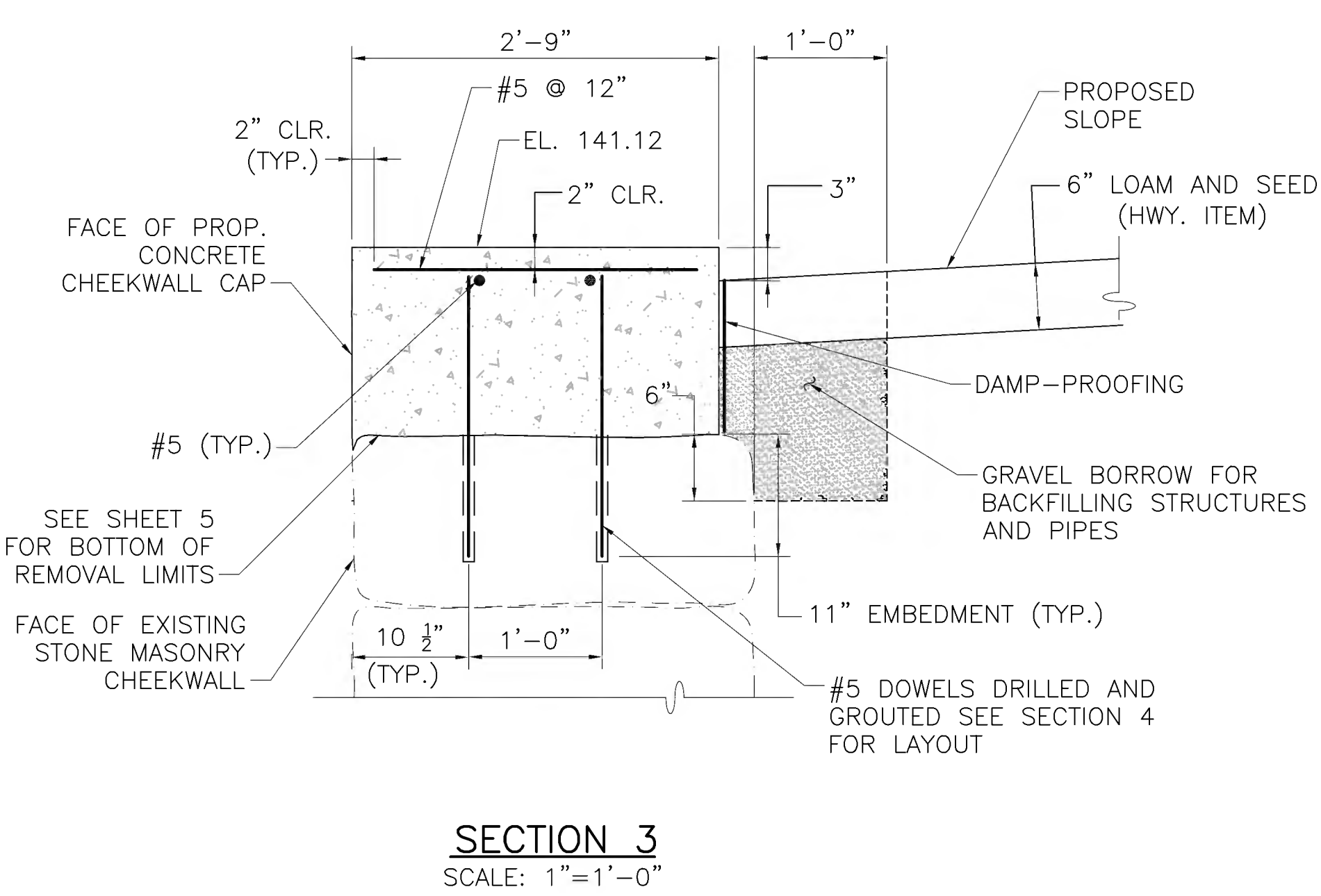
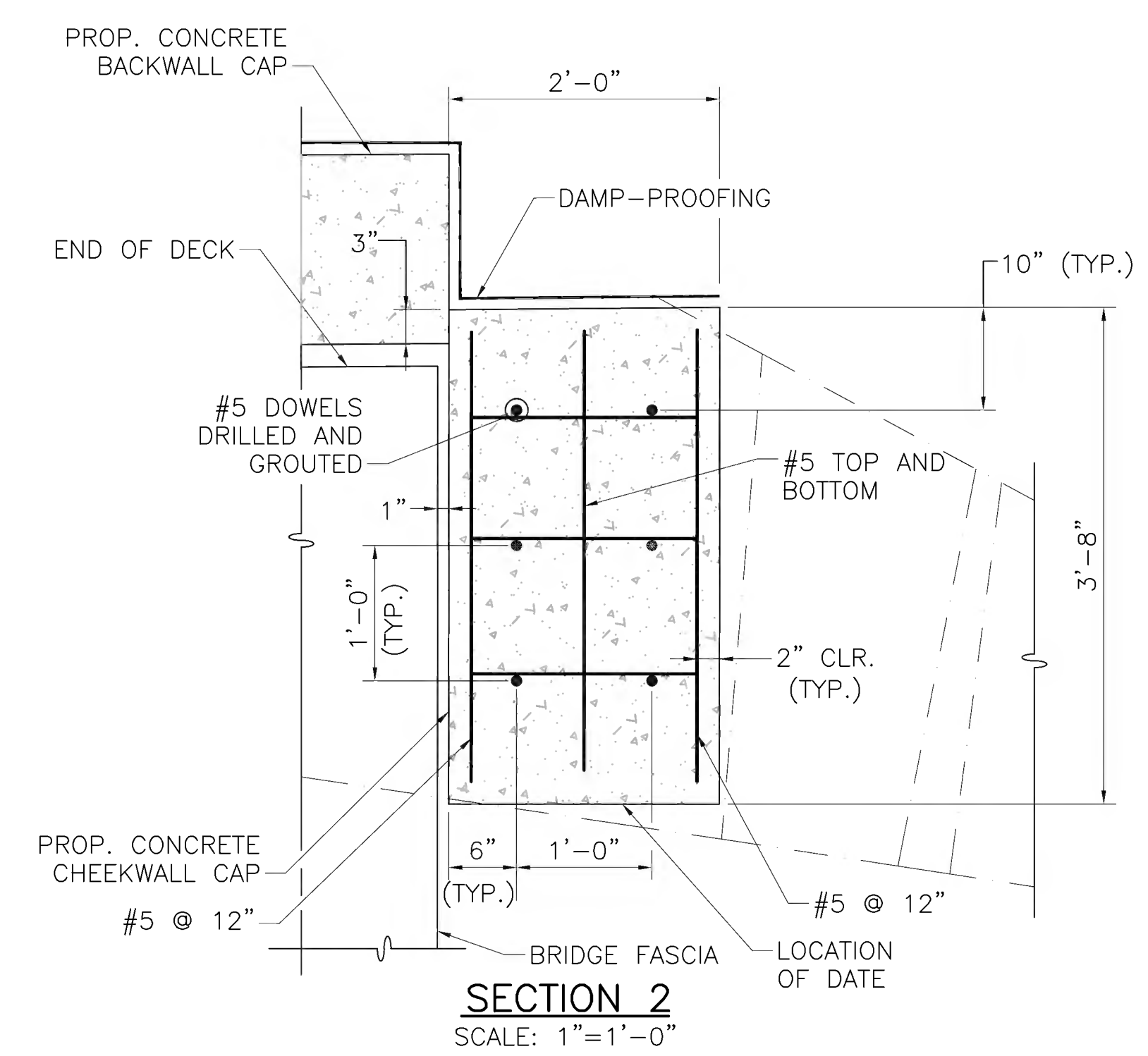
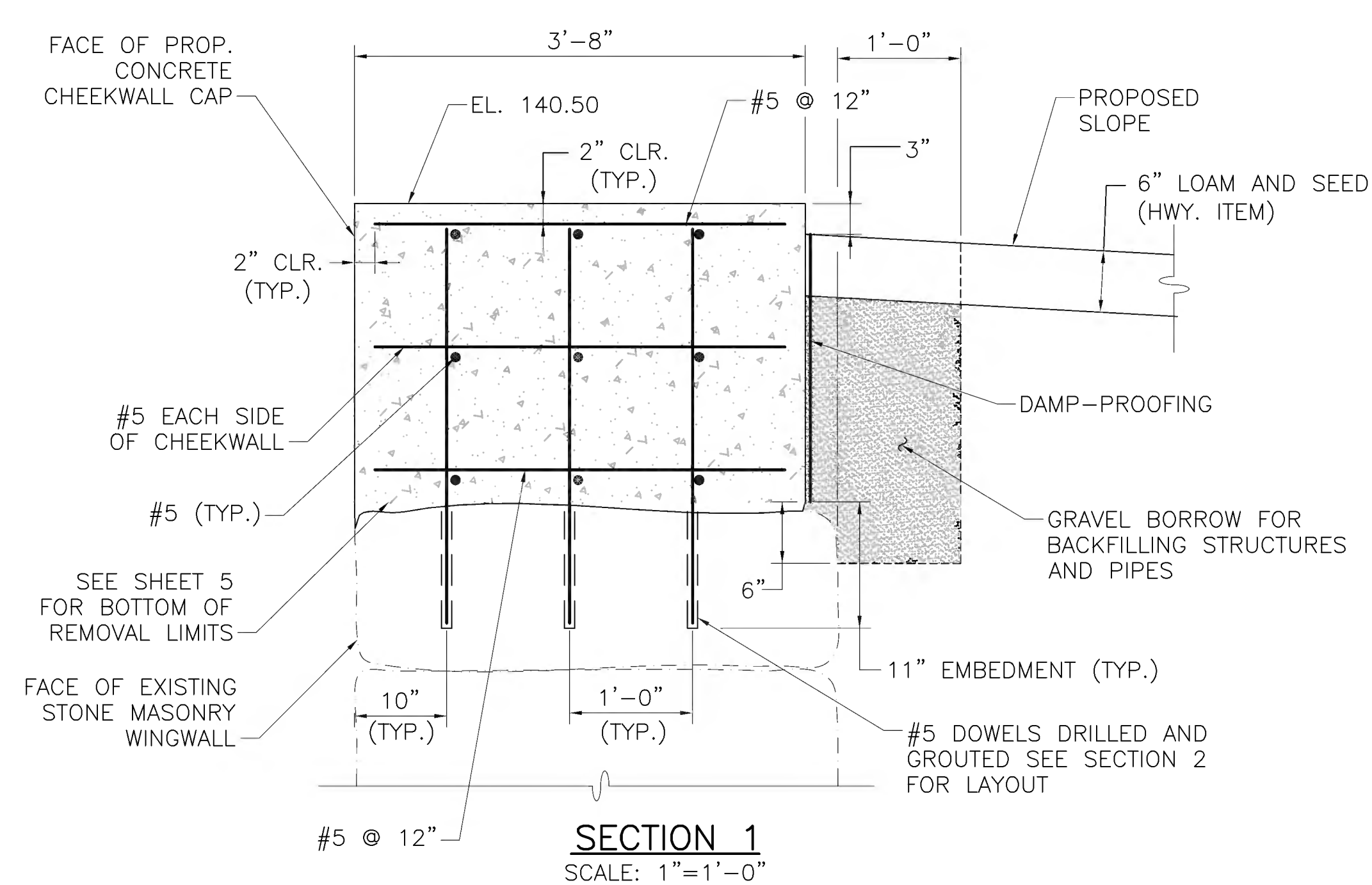

NOTE:
USE APPROVED NON-SHRINK GROUT WITH MINIMUM COMPRESSIVE STRENGTH F'c OF 6200 PSI.

EXISTING ABUTMENT REPAIR NOTES:

1. THE NORTH EXISTING STONE MASONRY ABUTMENT HAS A MISSING STONE IN THE FACE. THE CONTRACTOR SHALL REBUILD ANY COLLAPSED PORTIONS OF THE EXISTING WALL ALONG THE LENGTH OF THE ABUTMENT AND WINGWALLS BELOW THE LIMITS OF REMOVAL. THE COST TO REBUILD THE WALL AS REQUIRED SHALL BE INCLUDED IN ITEM 690, "STONE MASONRY WALL REMOVED AND REBUILT IN CEMENT MORTAR".
2. REPOINTING OF THE EXISTING STONE MASONRY ABUTMENTS SHALL BE REQUIRED PRIOR TO SUPERSTRUCTURE WORK. MASONRY REPOINTING AREAS SHALL BE DETERMINED IN THE FIELD BY THE ENGINEER. THE COST TO REPOINT SHALL BE INCLUDED IN ITEM 690.91, "MASONRY REPOINTING".
3. ANY WATER CONTROL REQUIRED TO REMOVE, REPAIR, REBUILD, OR REPOINT THE EXISTING ABUTMENTS SHALL BE INCLUDED UNDER ITEM 991.1, "CONTROL OF WATER".
4. THE CONFIGURATION OF THE EXISTING ABUTMENT STONE WALLS AND THE ELEVATION OF THE BOTTOM OF THE EXISTING ABUTMENTS SHOWN ON THE PLANS ARE APPROXIMATE.

NOTES:

1. WORK IN THE WATER SHALL BE PERFORMED DURING LOW FLOW SEASON AS DEFINED IN THE SPECIAL PROVISION FOR ITEM 991.1 AND THE FLOW SHALL BE MAINTAINED THROUGH THE USE OF TEMPORARY WATER CONTROL.
2. THE CONTRACTOR SHALL BE RESPONSIBLE FOR SIZING THE BARRIER TO HANDLE THE RIVER FLOW. THE BARRIER SHALL BE OF ADEQUATE SIZE TO DELIVER THE WATER AT THE DISCHARGE END TO THE RIVER WITHOUT DISTURBING THE EXISTING BANKS OR RIVERBED FLOW. THE BARRIER HEIGHT SHALL BE SIZED TO MAINTAIN 1' OF FREEBOARD OVER THE 10-YEAR FLOOD.
3. IN THE EVENT OF HIGH FLOW RATES, THE CONTRACTOR SHALL BE RESPONSIBLE TO DEVELOP AND IMPLEMENT A REASONABLE MEANS NECESSARY TO HANDLE THE ADDITIONAL FLOWS TO PROTECT THE SURROUNDING AREA, AS APPROVED BY THE ENGINEER AND SHALL BE INCIDENTAL TO ITEM 991.1 "CONTROL OF WATER - STRUCTURE NO. S-31-007".

MONTH DD, YYYY	ISSUED FOR CONSTRUCTION
DATE	DESCRIPTION
USE ONLY PRINTS OF LATEST DATE	

608164-BRF(S-31-007)ABUT DETAILS.DWG Plotted on 18-Feb-2022 2:41 PM 2nd Structural Submittal (S2) 18-January-2022

STATE	FED. AID PROJ. NO.	SHEET NO.	TOTAL SHEETS
MA	XXX-XXXX(XXX)X	231	319
PROJECT FILE NO.		608164	

BEARING DETAILS

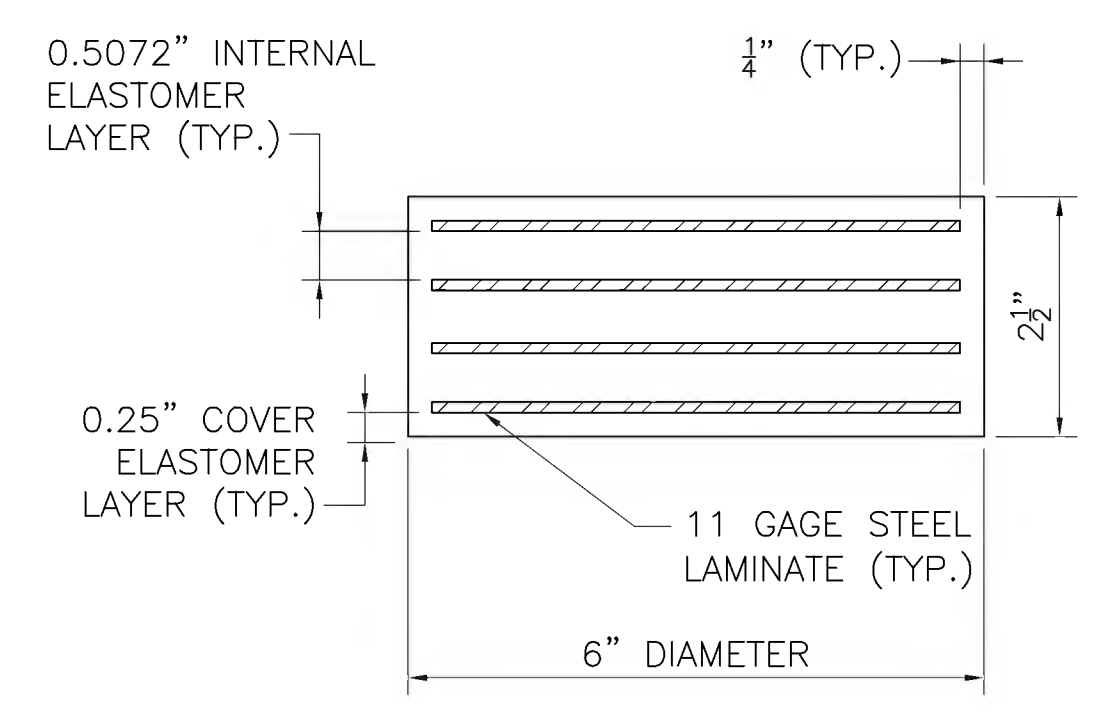
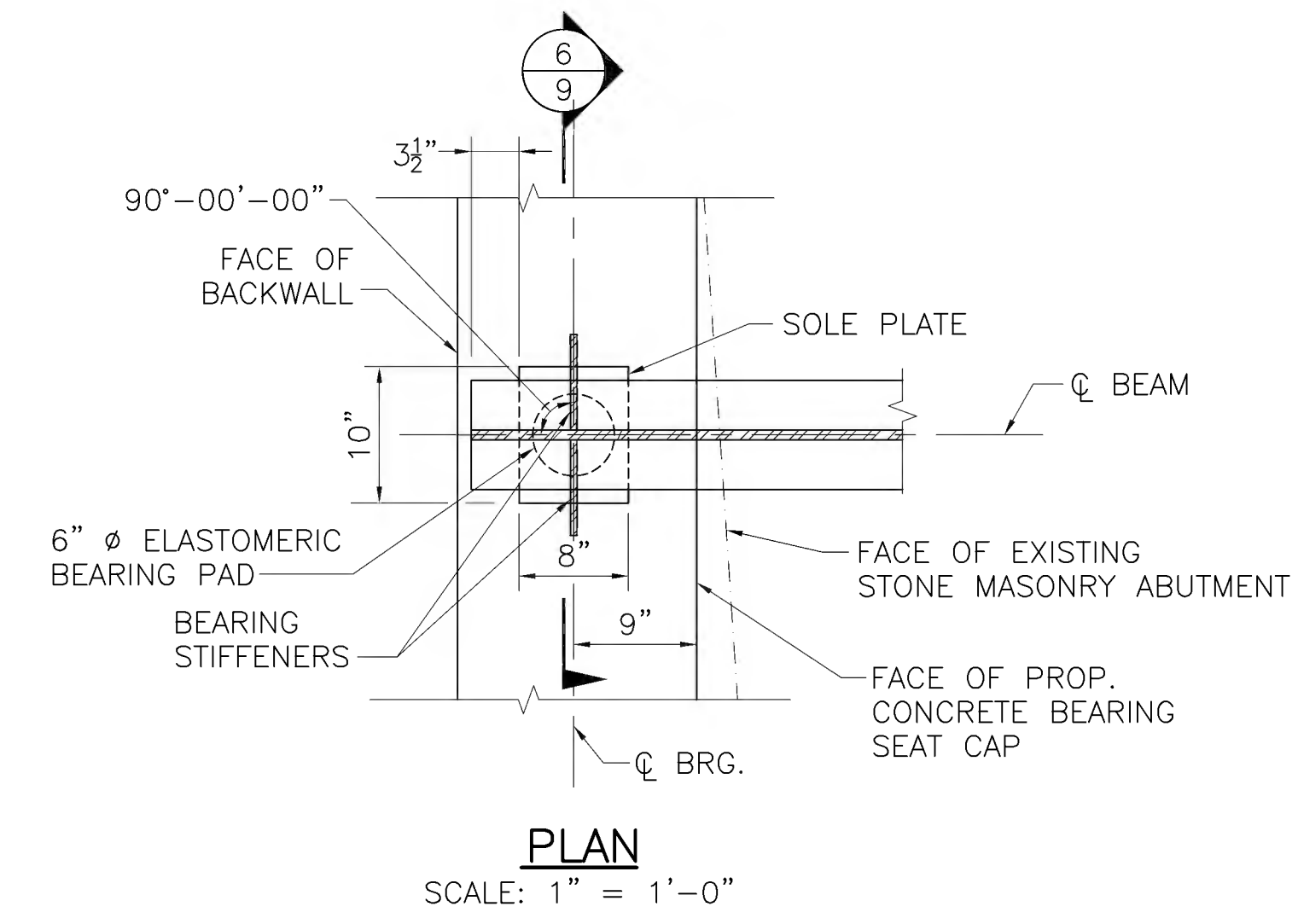

- NOTES:**
- ELASTOMER SHALL HAVE A SHEAR MODULUS OF 0.160 KSI.
 - STEEL LAMINATES SHALL CONFORM TO ASTM A 1011 GRADE 36.
 - THE COMPRESSIVE DESIGN LOAD ON THE BEARING PAD IS 8 KIPS. THE COMPRESSIVE DESIGN STRESS IS THE RESULT OF DIVIDING THE COMPRESSIVE DESIGN LOAD BY THE AREA OF THE PAD AND IS EQUAL TO 0.28 KSI.
 - ELASTOMERIC BEARING PAD SHALL NOT BE VULCANIZED TO THE SOLE PLATE.
 - ELASTOMER SHALL HAVE A HARDNESS OF 60 DUROMETER.

ELASTOMERIC BEARING PAD
6" = 1'-0"

- BEARING NOTES:**
- STEEL SOLE PLATES SHALL CONFORM TO AASHTO M 270 GRADE 36 AND SHALL BE HOT-DIP GALVANIZED.
 - CENTER THE ELASTOMERIC PAD UNDER THE SOLE PLATE DURING BEAM ERECTION.
 - BEAMS SHALL BE ERECTED WHEN THE AMBIENT TEMPERATURE IS BETWEEN 50 °F AND 77 °F. IF BEAMS ARE ERECTED AT OTHER AMBIENT TEMPERATURES, THEY WILL HAVE TO BE JACKED AND THE ELASTOMERIC BEARINGS RECENTERED WHEN THE TEMPERATURE RETURNS TO THAT RANGE.

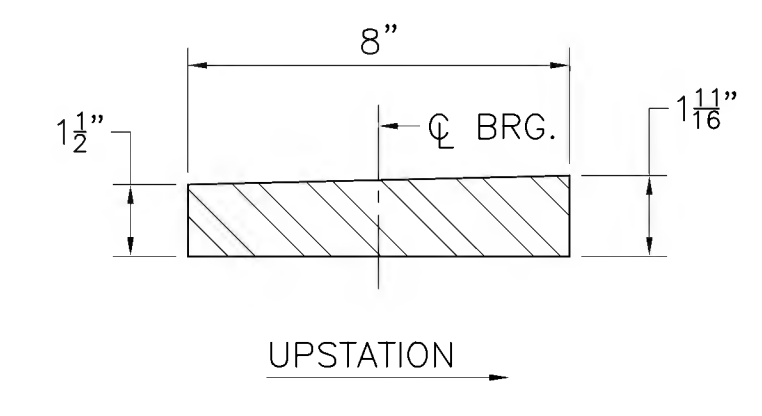
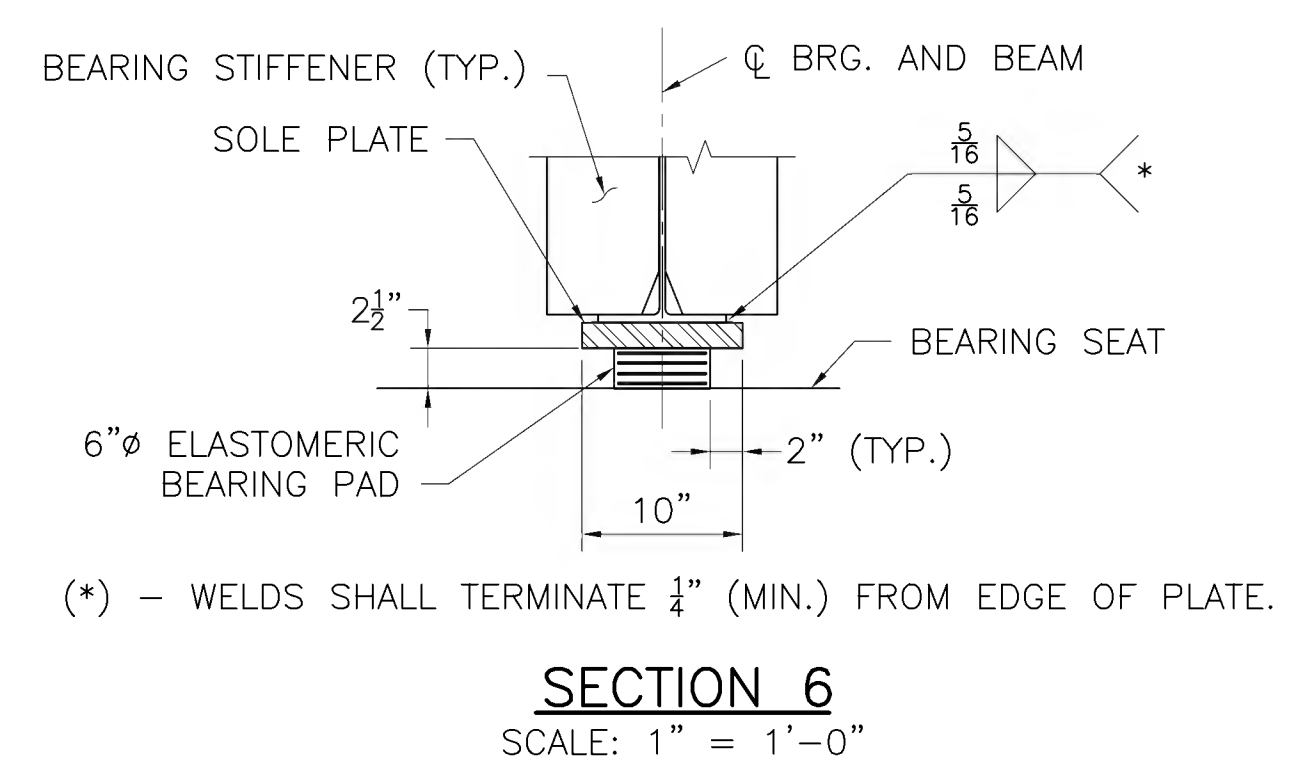

SOUTH ABUTMENT SOLE PLATE DETAIL
SCALE: 3" = 1'-0"

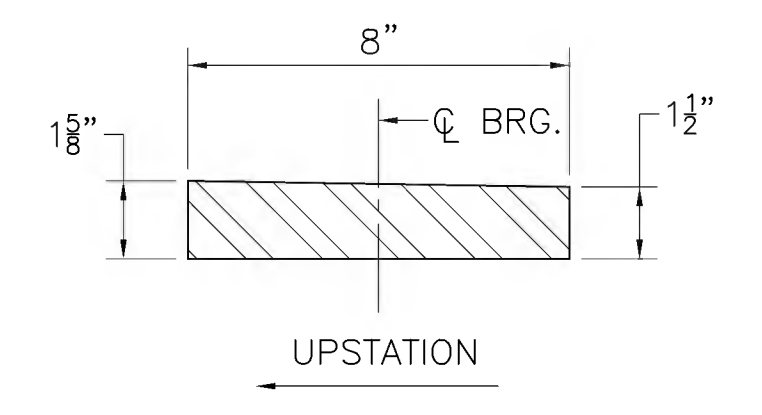
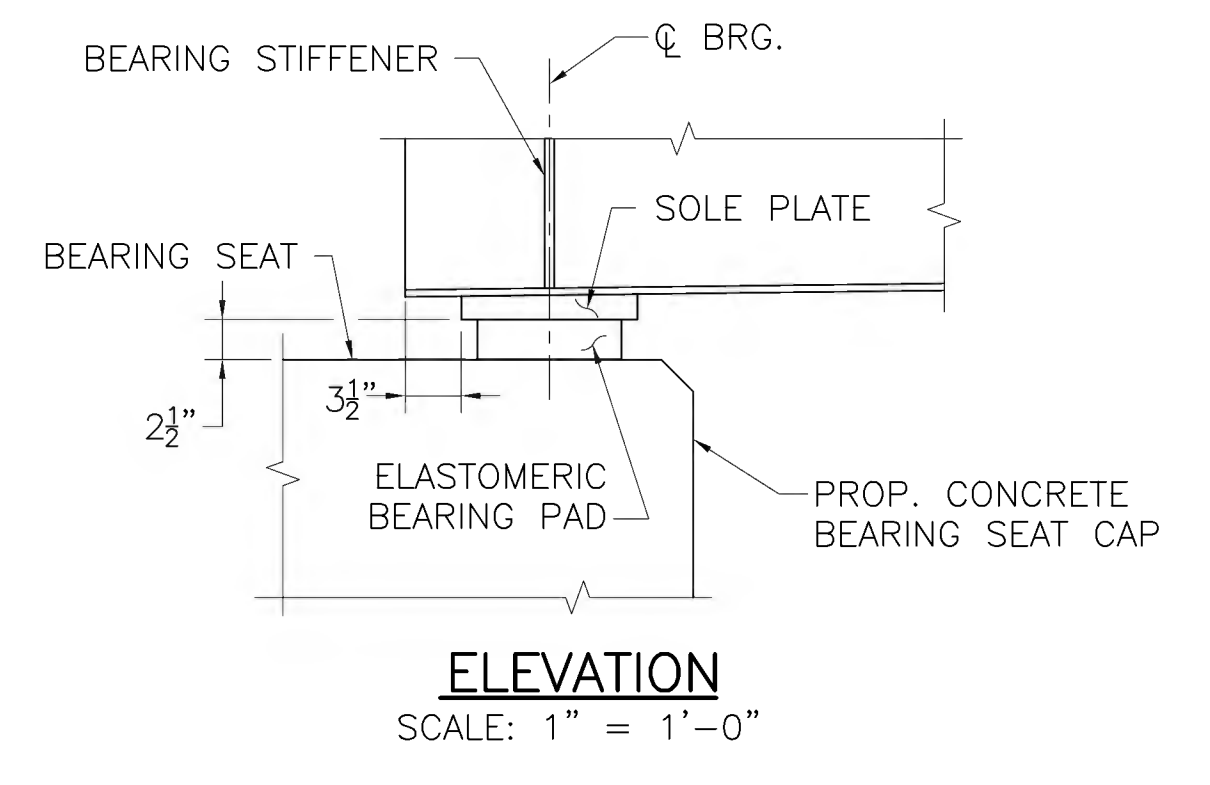

NORTH ABUTMENT SOLE PLATE DETAIL
SCALE: 3" = 1'-0"

MONTH DD, YYYY	ISSUED FOR CONSTRUCTION
DATE	DESCRIPTION
USE ONLY PRINTS OF LATEST DATE	

608164-BR10(S-31-007)BEARINGS.DWG Potted on 18-Feb-2022 2:41 PM 2nd Structural Submittal (S2) 18-January-2022

STATE	FED. AID PROJ. NO.	SHEET NO.	TOTAL SHEETS
MA	XXX-XXXX(XXX)X	232	319
PROJECT FILE NO.		608164	

FRAMING PLAN & STRUCTURAL STEEL DETAILS

NOTES:

- D1 = C9x15 (TYPICAL DIAPHRAGM)
- THE MAIN LOAD CARRYING MEMBERS ARE BM #1 THROUGH BM #7. ALL BEAMS SHALL BE W12x40.
- ALL STEEL SHALL CONFORM TO AASHTO M270 GRADE 50 HOT-DIP GALVANIZED.
- ALL BEARING STIFFENERS SHALL BE PLUMB.
- ENDS OF BEAMS SHALL BE FABRICATED SO THAT UNDER FULL DEAD LOAD THE ENDS OF THE BEAMS WILL PLUMB.
- BEARING STIFFENER PLATES AT BOTTOM FLANGE SHALL BE MILLED FOR TIGHT FIT AND WELDED WITH $\frac{5}{16}$ " FILLET WELDS, BOTH SIDES OF PLATE.

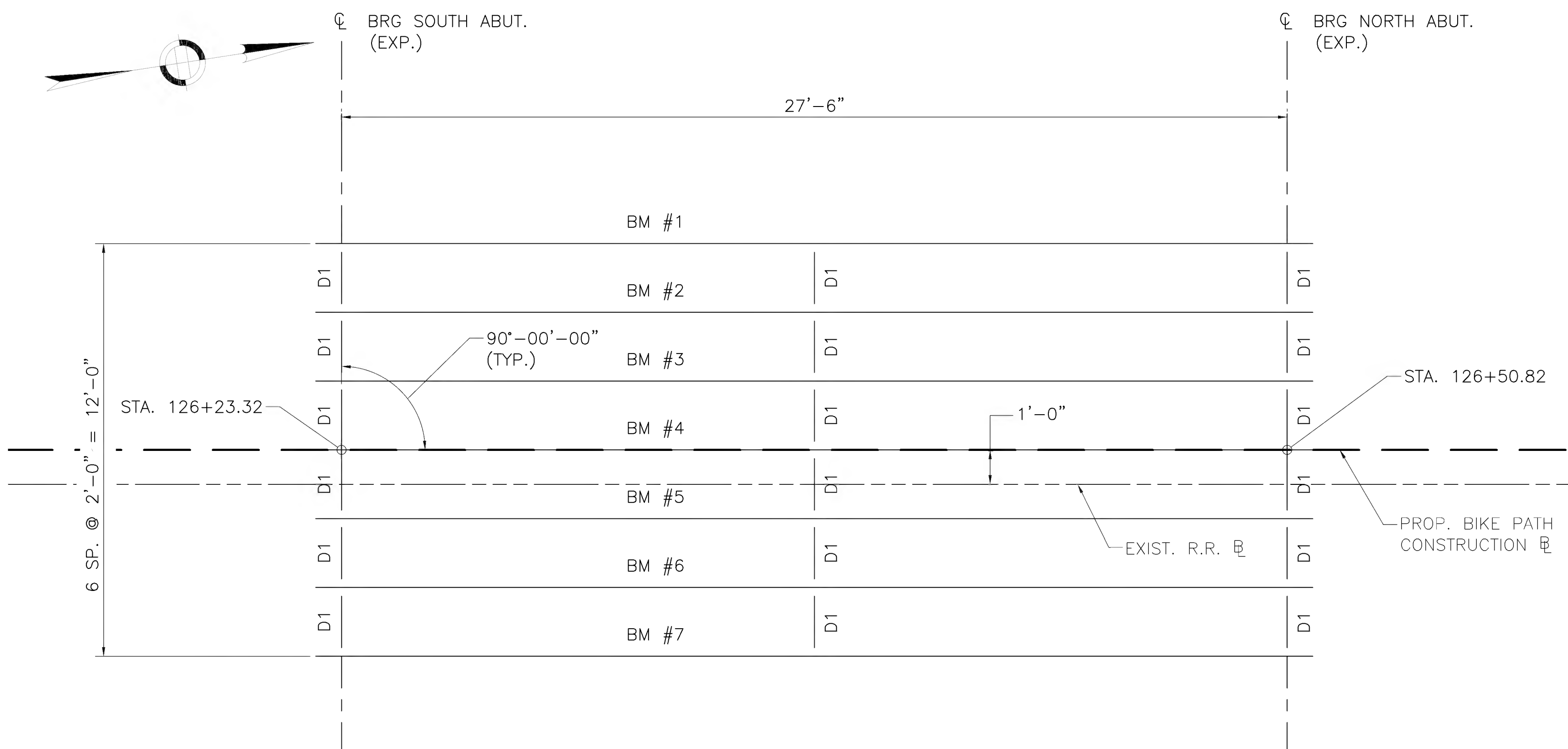

FRAMING PLAN
SCALE: $\frac{3}{8}$ " = 1'-0"

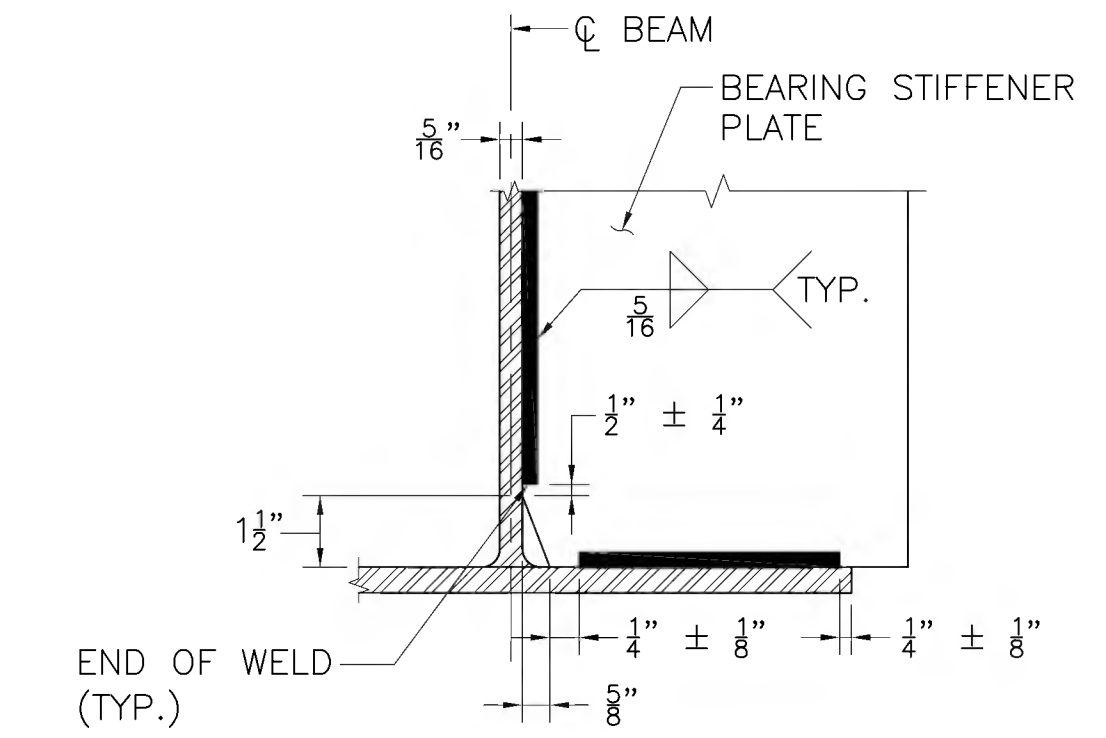

CLIP DETAIL
NOT TO SCALE

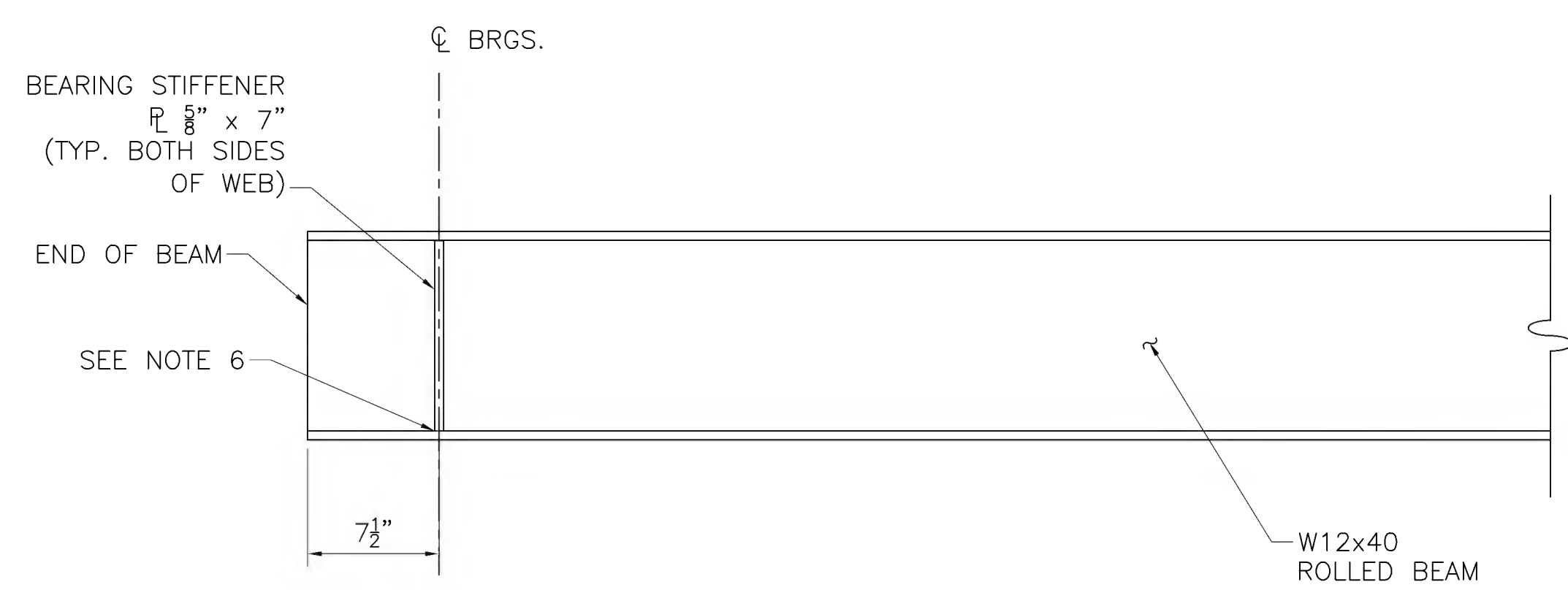

BEAM ELEVATION
SCALE: $1\frac{1}{2}$ " = 1'-0"

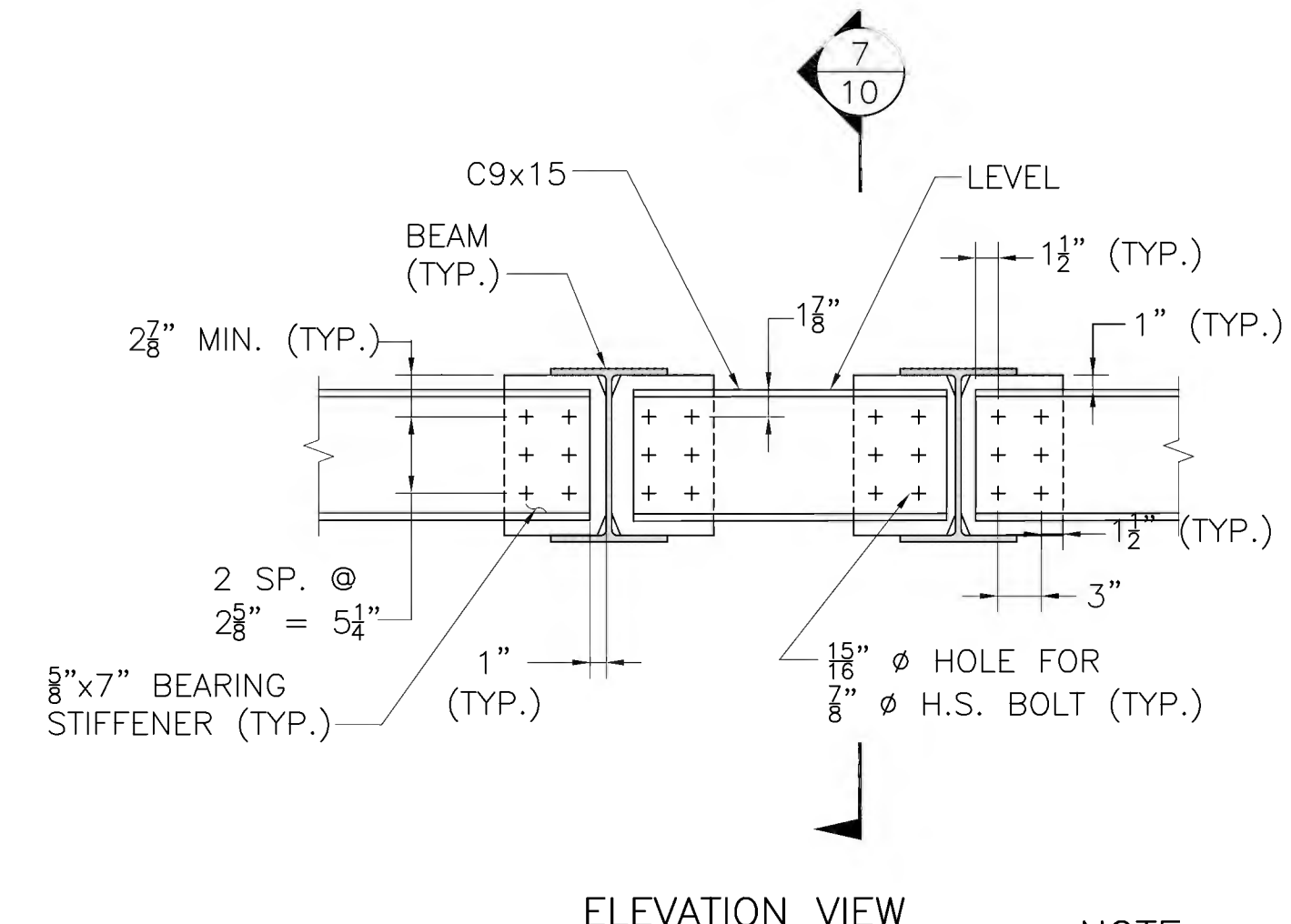

ELEVATION VIEW

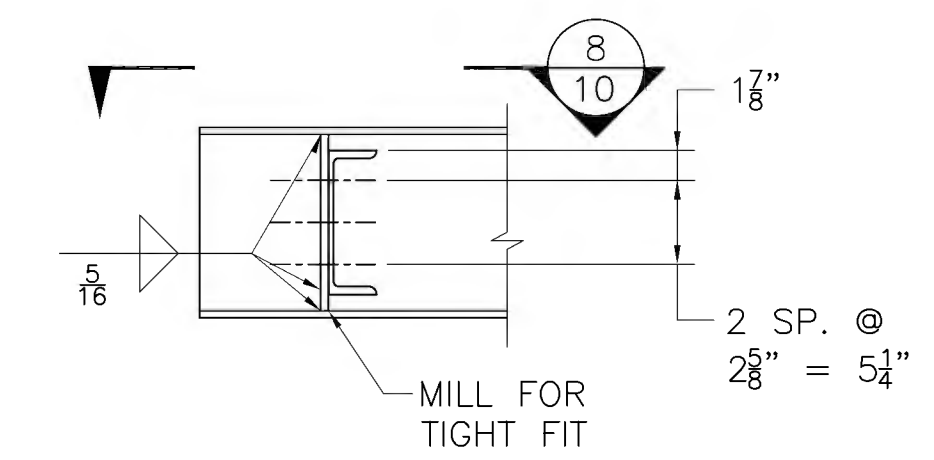

SECTION 7

NOTE:
SEE CLIP DETAIL ON THIS SHEET.

DIAPHRAGM D1
SCALE: 1" = 1'-0"

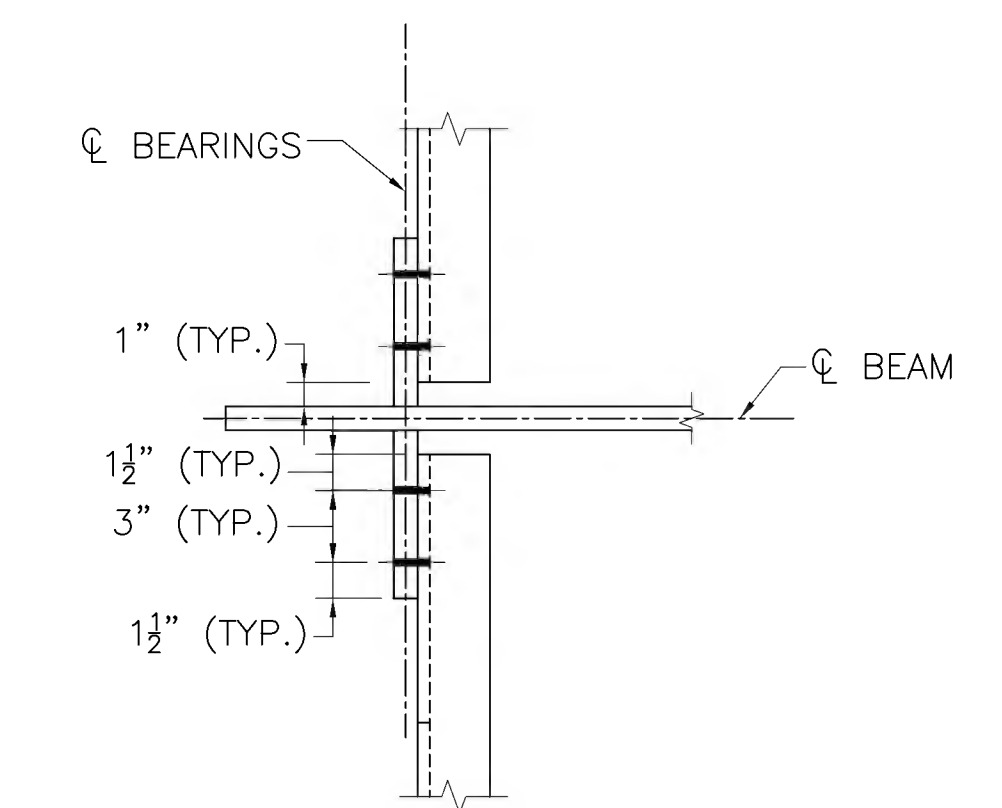

SECTION 8
SCALE: $1\frac{1}{2}$ " = 1'-0"

	CAMBER TABLE (INCHES)										
	SPAN NO. 1										
	S. ABUT.	0.1L	0.2L	0.3L	0.4L	0.5L	0.6L	0.7L	0.8L	0.9L	N. ABUT.
STEEL DL DEFLECTION	0.00	0.02	0.03	0.05	0.06	0.06	0.06	0.05	0.03	0.02	0.00
NONCOMP. DEFLECTION	0.00	0.03	0.05	0.06	0.07	0.07	0.07	0.06	0.05	0.03	0.00
ADDITIONAL CAMBER	0.00	0.07	0.14	0.21	0.28	0.34	0.28	0.21	0.14	0.07	0.00
TOTAL CAMBER	0.00	0.12	0.22	0.32	0.41	0.47	0.41	0.32	0.22	0.12	0.00

MONTH DD, YYYY	ISSUED FOR CONSTRUCTION
DATE	DESCRIPTION
USE ONLY PRINTS OF LATEST DATE	

608164_BRT1(S-31-007)FRAME.DWG Picked on 18-Feb-2022 2:42 PM 2nd Structural Submittal (S2) 18-January-2022

STATE	FED. AID PROJ. NO.	SHEET NO.	TOTAL SHEETS
MA	XXX-XXXX(XXX)X	233	319
PROJECT FILE NO.		608164	

DECK DETAILS & TYPICAL SECTION

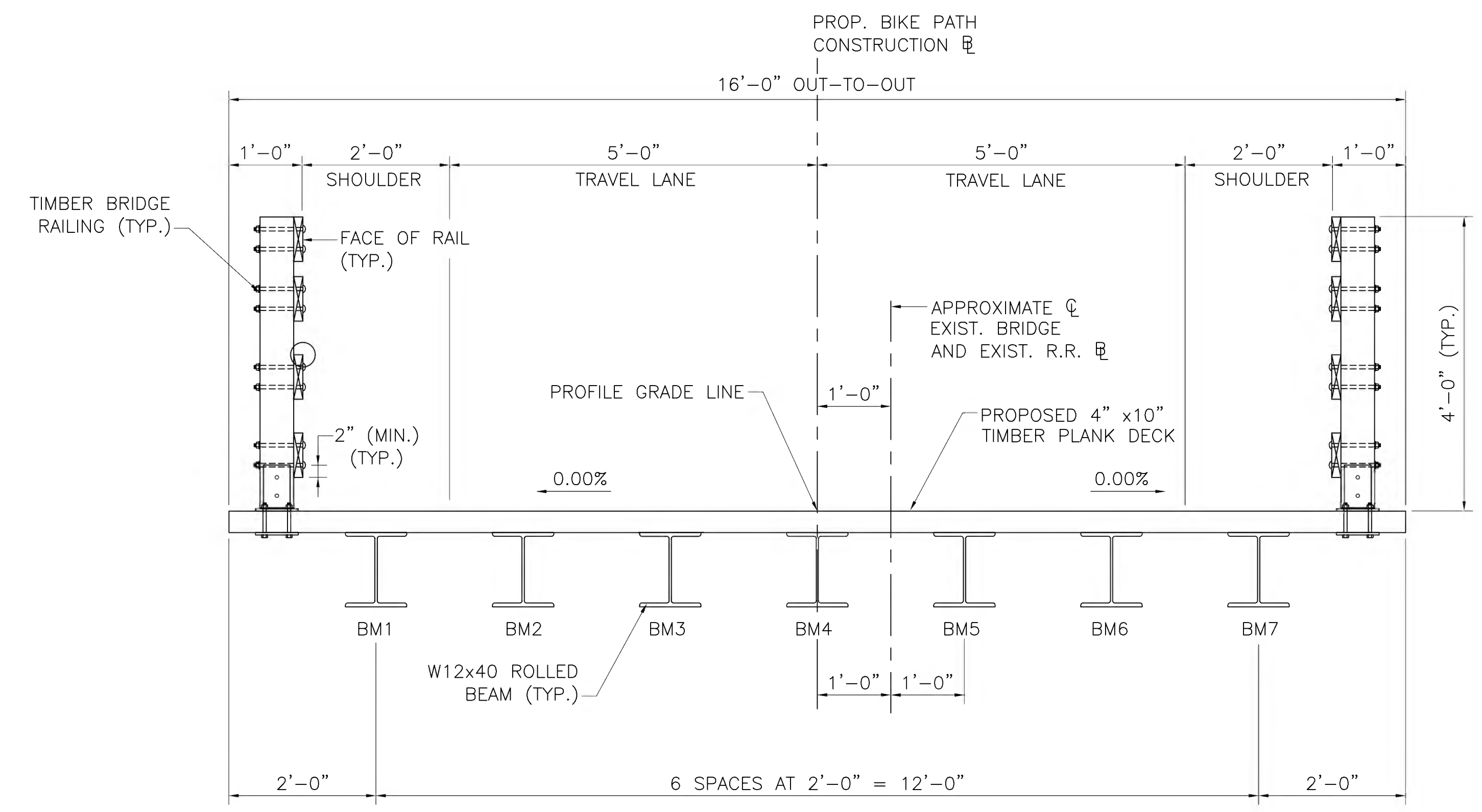

TYPICAL BRIDGE SECTION
SCALE: 3/4" = 1'-0"

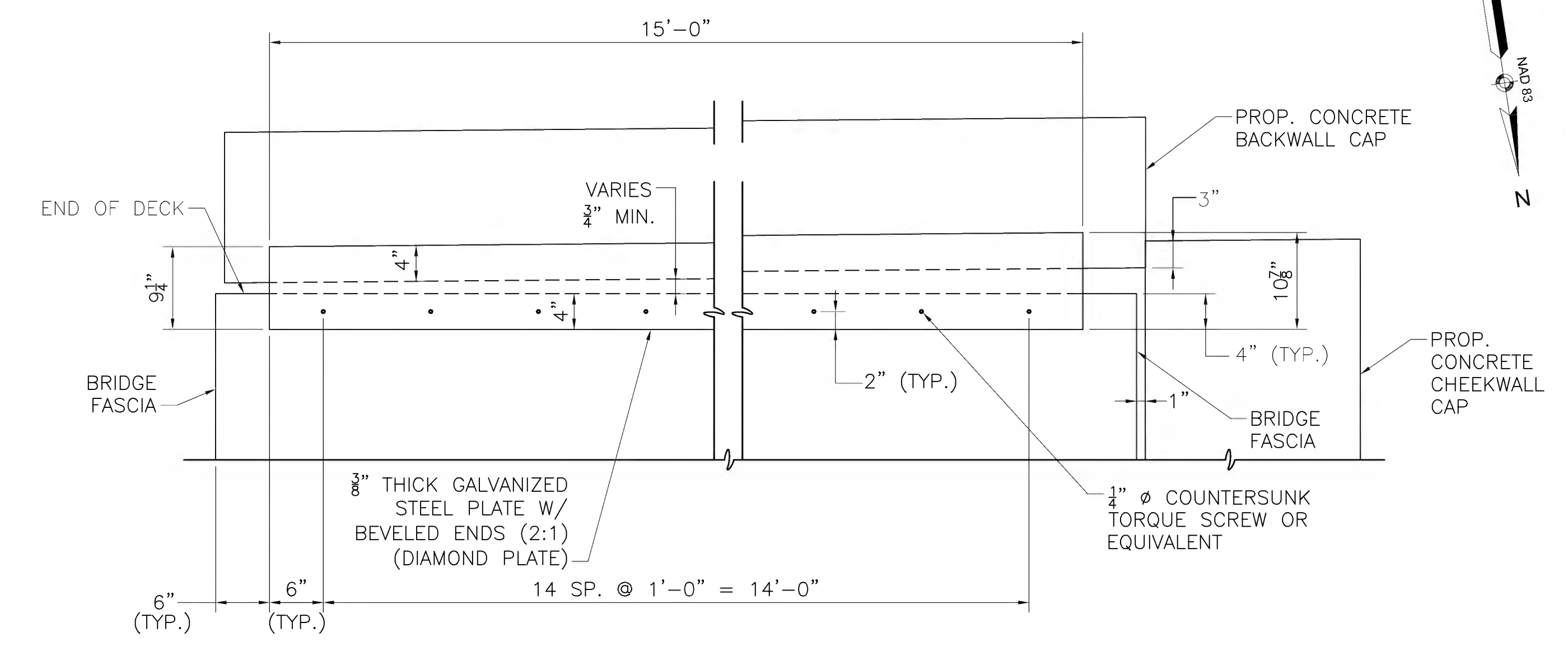

SOUTH DECK END PLATE DETAIL
SCALE: 1" = 1'-0"

NOTE:
BEAMS AND BEARING SEAT NOT SHOWN FOR CLARITY.

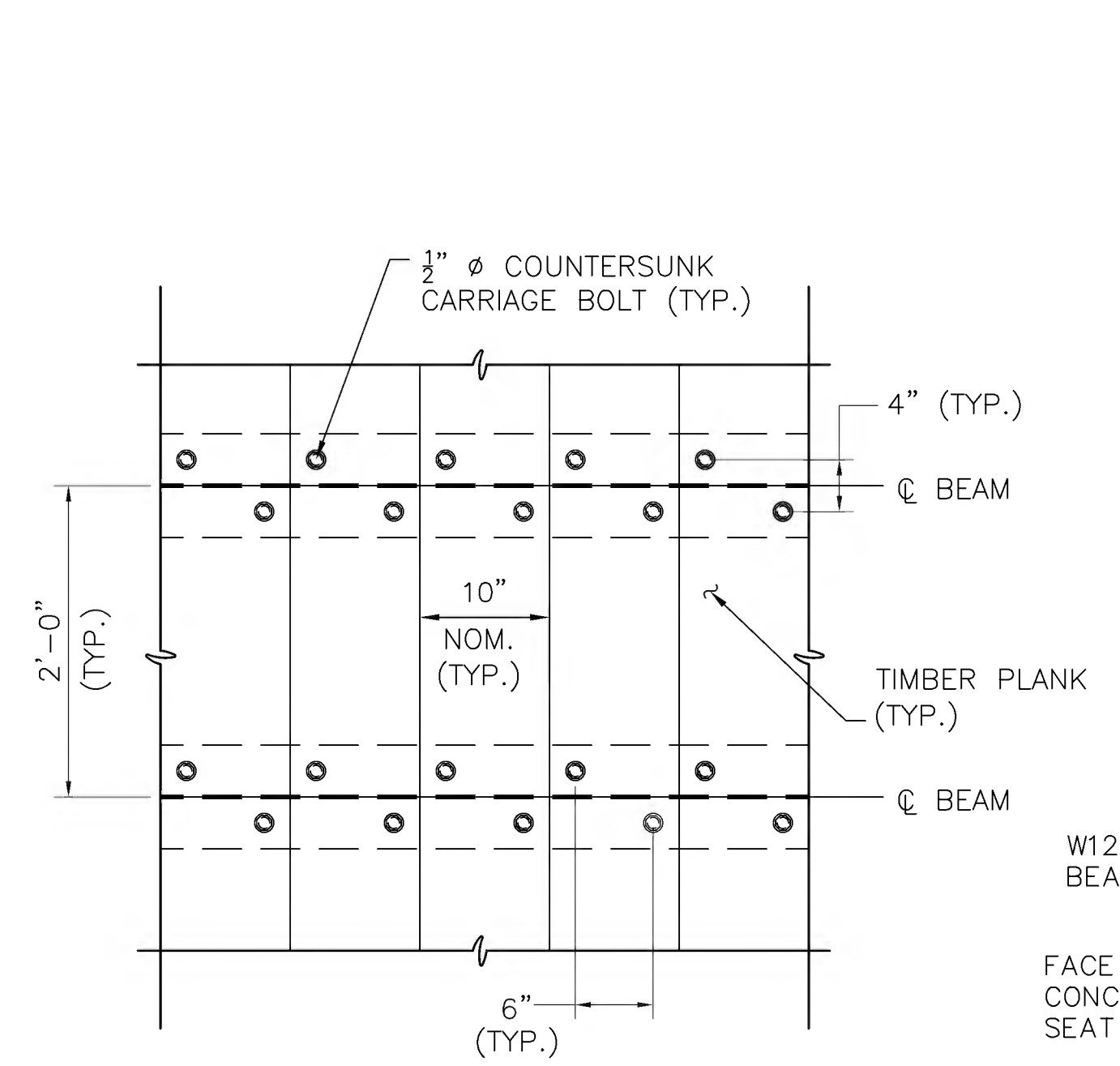

DECK CONNECTION DETAIL
SCALE: 1" = 1'-0"

NOTE:
CONNECTION SHOULD BE CENTERED ON PLANKS AND BEAMS.

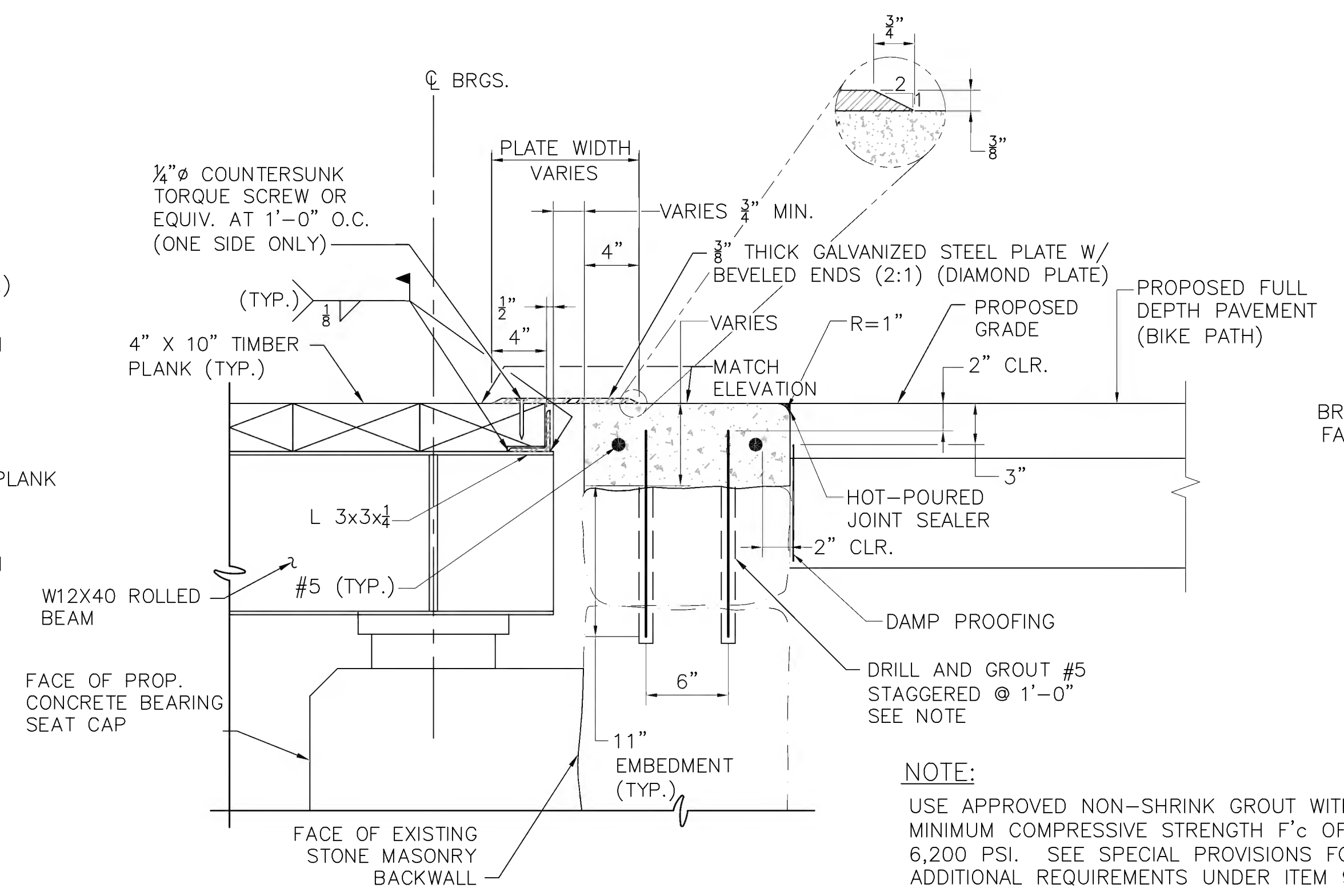

TYPICAL ABUTMENT END DETAIL
SCALE: 1 1/2" = 1'-0"

NOTE:
USE APPROVED NON-SHRINK GROUT WITH MINIMUM COMPRESSIVE STRENGTH F'c OF 6,200 PSI. SEE SPECIAL PROVISIONS FOR ADDITIONAL REQUIREMENTS UNDER ITEM 995

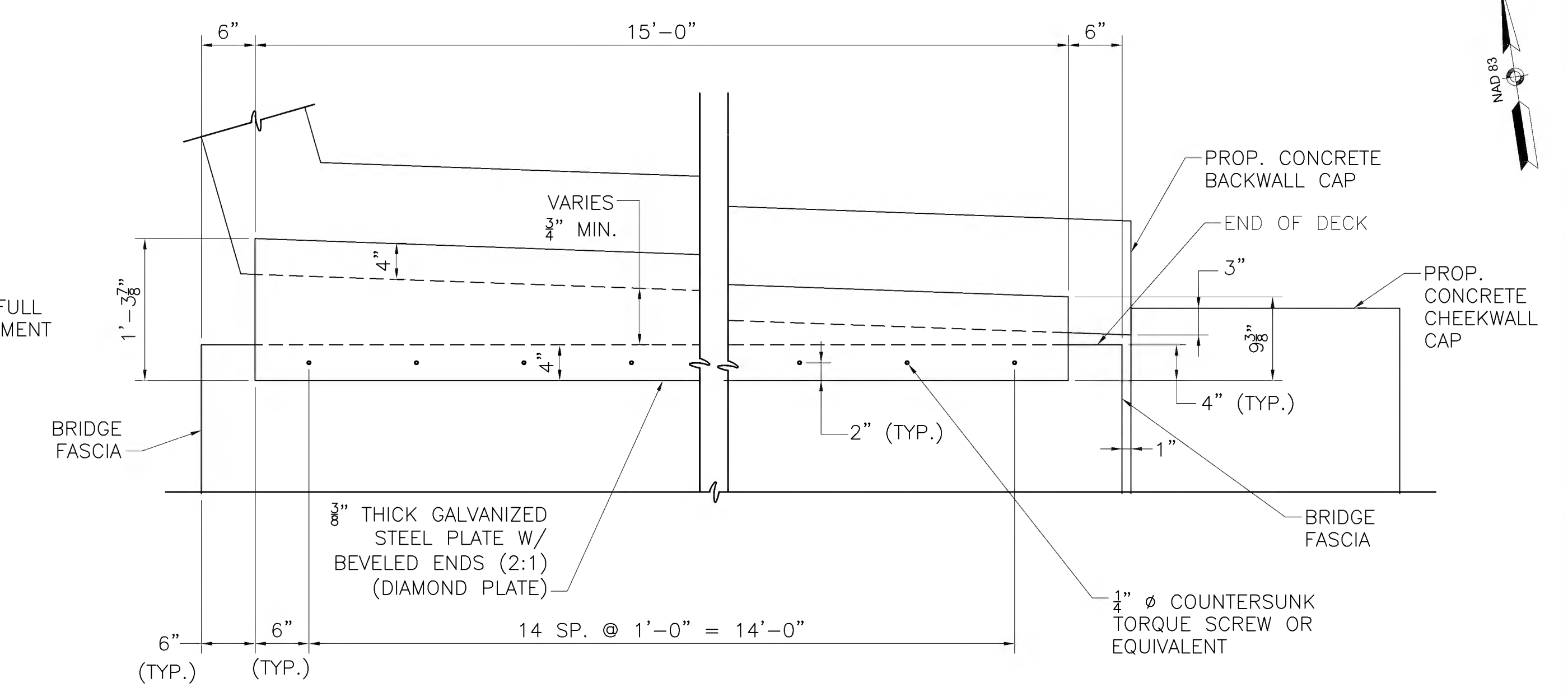

NORTH DECK END PLATE DETAIL
SCALE: 1" = 1'-0"

MONTH DD, YYYY	ISSUED FOR CONSTRUCTION
DATE	DESCRIPTION
USE ONLY PRINTS OF LATEST DATE	

608164_BR(3)(S-31-007)(DECK DETAILS).DWG Plotted on 18-Feb-2022 2:42 PM 2nd Structural Submittal (S2) 18-January-2022

STATE	FED. AID PROJ. NO.	SHEET NO.	TOTAL SHEETS
MA	XXX-XXXX(XXX)X	234	319
PROJECT FILE NO.		608164	

TIMBER BRIDGE RAIL DETAILS

RAILING NOTES:

- RAIL CONNECTION PLATES AND RAIL EXPANSION JOINT PLATES SHALL CONFORM TO THE REQUIREMENTS OF AASHTO M270 GRADE 50.
- ALL STEEL PLATES AND FASTENERS SHALL BE GALVANIZED.
- THE NUT SECURING THE POST BASE PLATE TO THE TIMBER DECK SHALL BE TIGHTENED TO A SNUG FIT AND GIVEN AN ADDITIONAL 1/8 TURN AFTER STEEL IS IN PLACE.
- CONNECTION BOLTS SHALL BE ASTM A325 TYPE 1.
- RAIL POSTS SHALL NOT FALL WITHIN 2" OF EDGE OF PLANK. ADJUST RAIL SPACING TO BE NOT MORE THAN 5'-0" SPACING ON BRIDGE TO ACCOMMODATE 2" EDGE DISTANCE LIMIT. HOLD 7' SPACING BETWEEN LAST POST ON THE BRIDGE AND FIRST POST OFF THE BRIDGE.
- ALL WOOD RAILS SHALL BE CONNECTED TO A MINIMUM OF TWO WOOD POSTS.
- BOLTS IN SLOTTED HOLES SHALL UTILIZE LOCK NUTS AND BE FINGER TIGHT TO ALLOW MOVEMENT BETWEEN STEEL PLATE AND TIMBER RAIL.
- SEE TIMBER RAIL FENCE DETAILS ON SHEET 209 FOR ADDITIONAL INFORMATION.

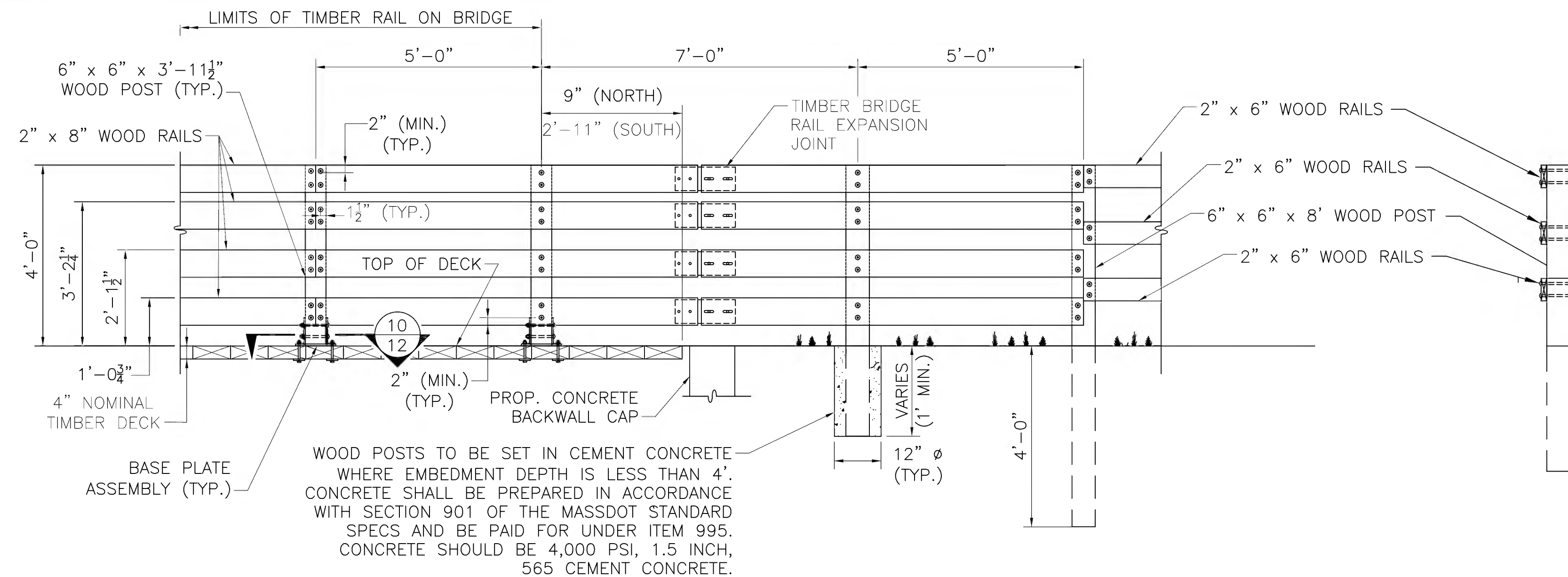

TIMBER BRIDGE RAIL ELEVATION

SCALE: 1/2"=1'-0"

NOTE: BASE PLATE BOLTS NOT SHOWN FOR CLARITY

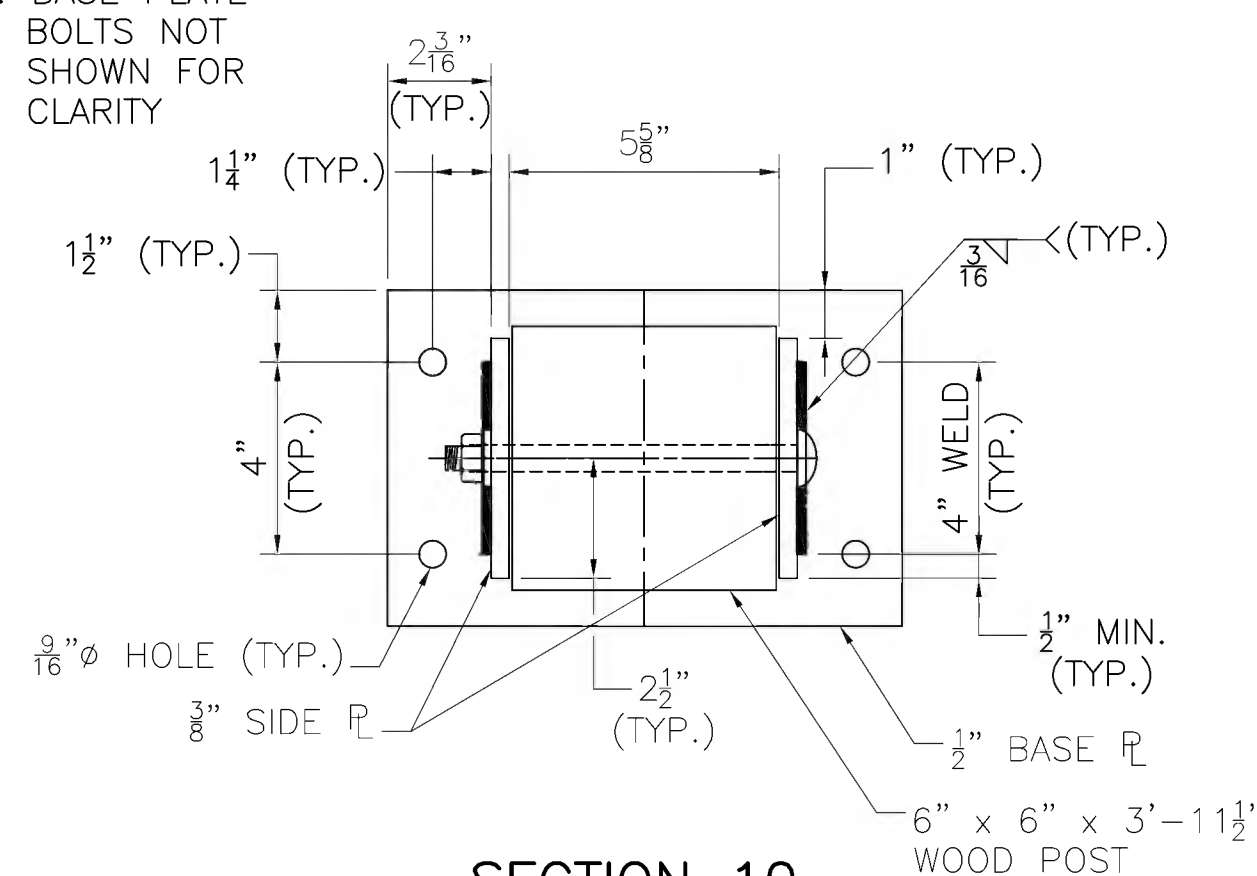

SECTION 10

SCALE: 3"=1'-0"

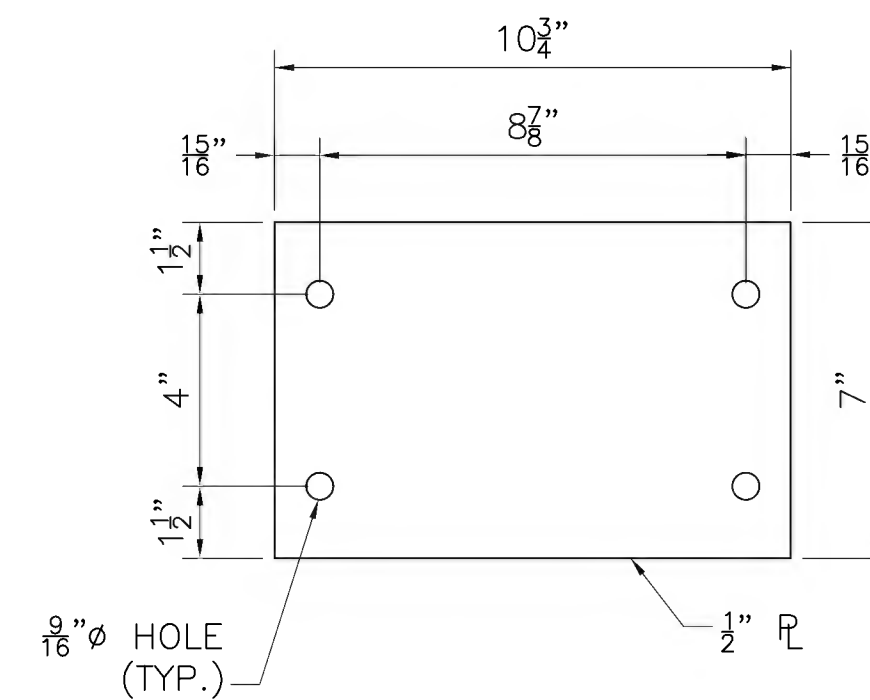

BASE PLATE

SCALE: 3"=1'-0"

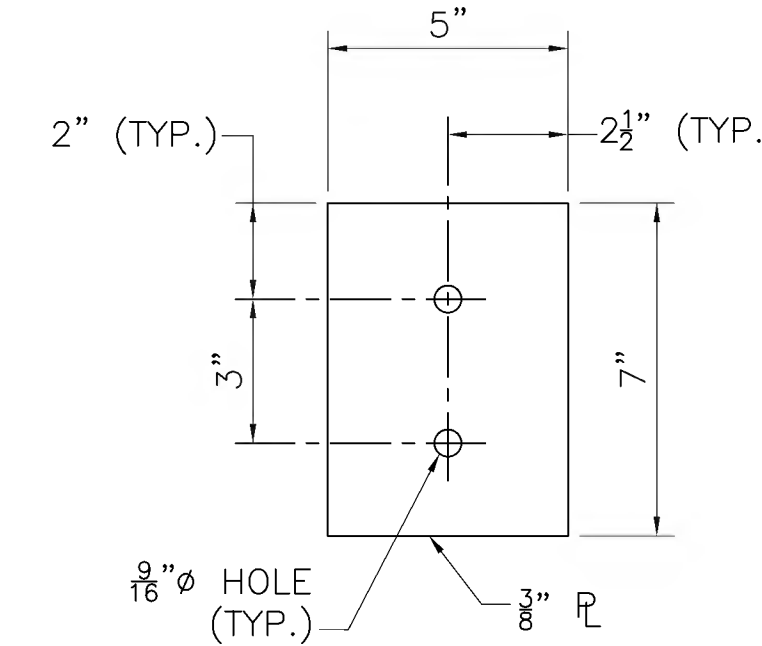

SIDE PLATE

SCALE: 3"=1'-0"

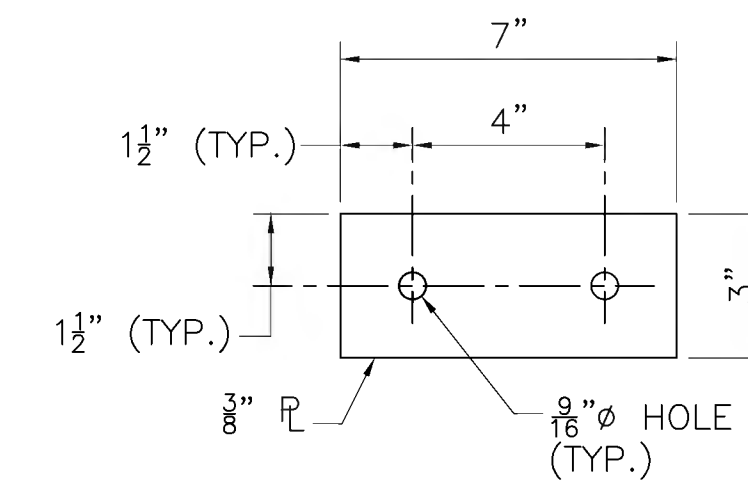

WASHER PLATE

SCALE: 3"=1'-0"

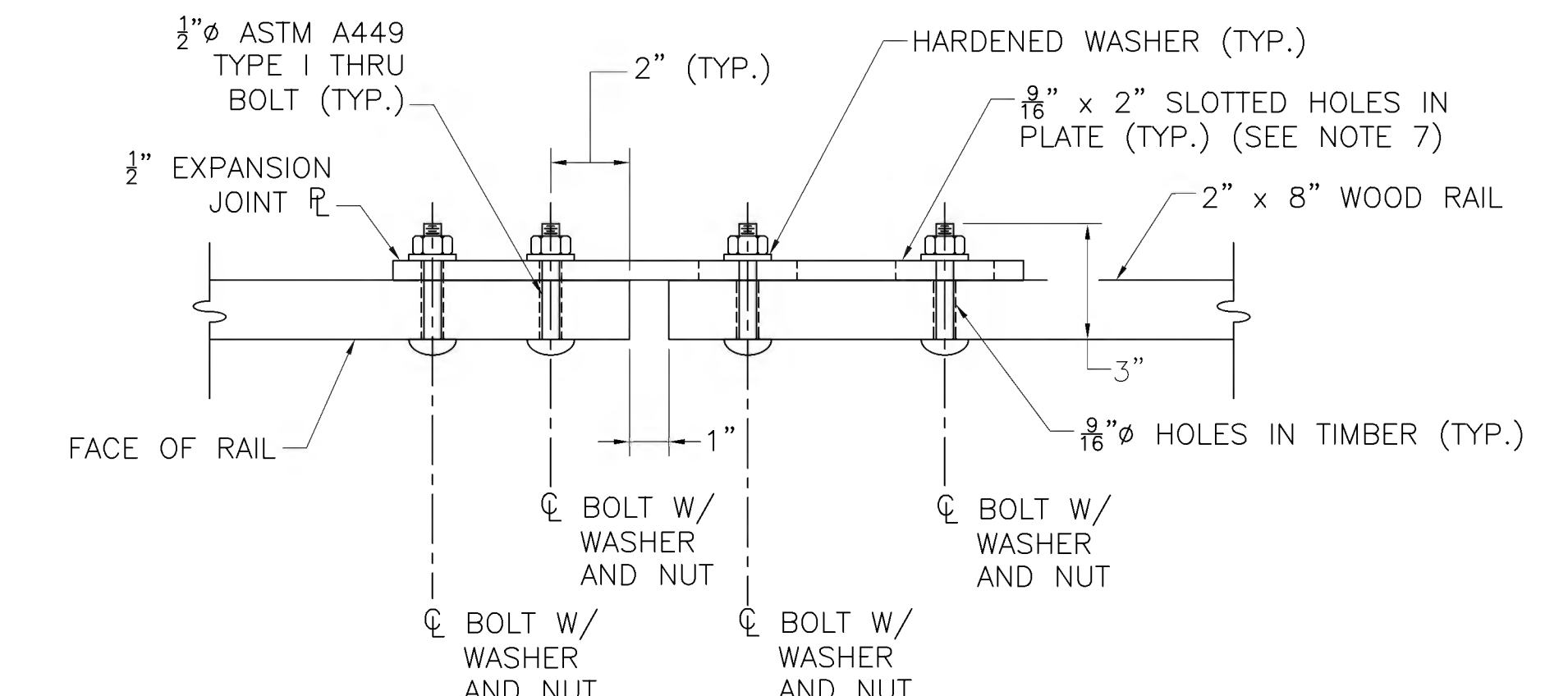

TOP EXPANSION JOINT VIEW

SCALE: 3"=1'-0"

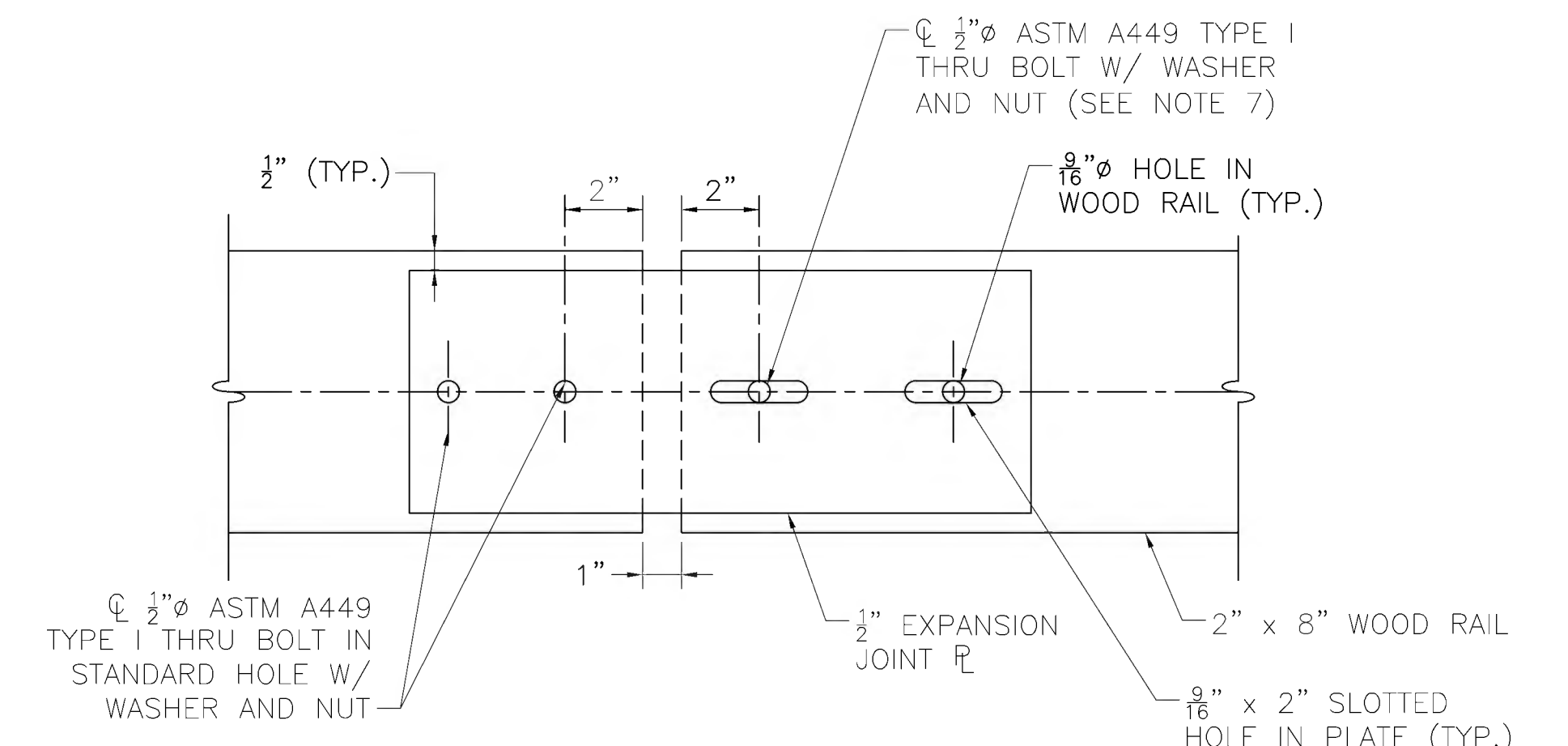

BACK EXPANSION JOINT ELEVATION

SCALE: 3"=1'-0"

NOTE: RAIL BUTT JOINT SHOWN, RAIL CONTINUOUS OVER POST SIMILAR

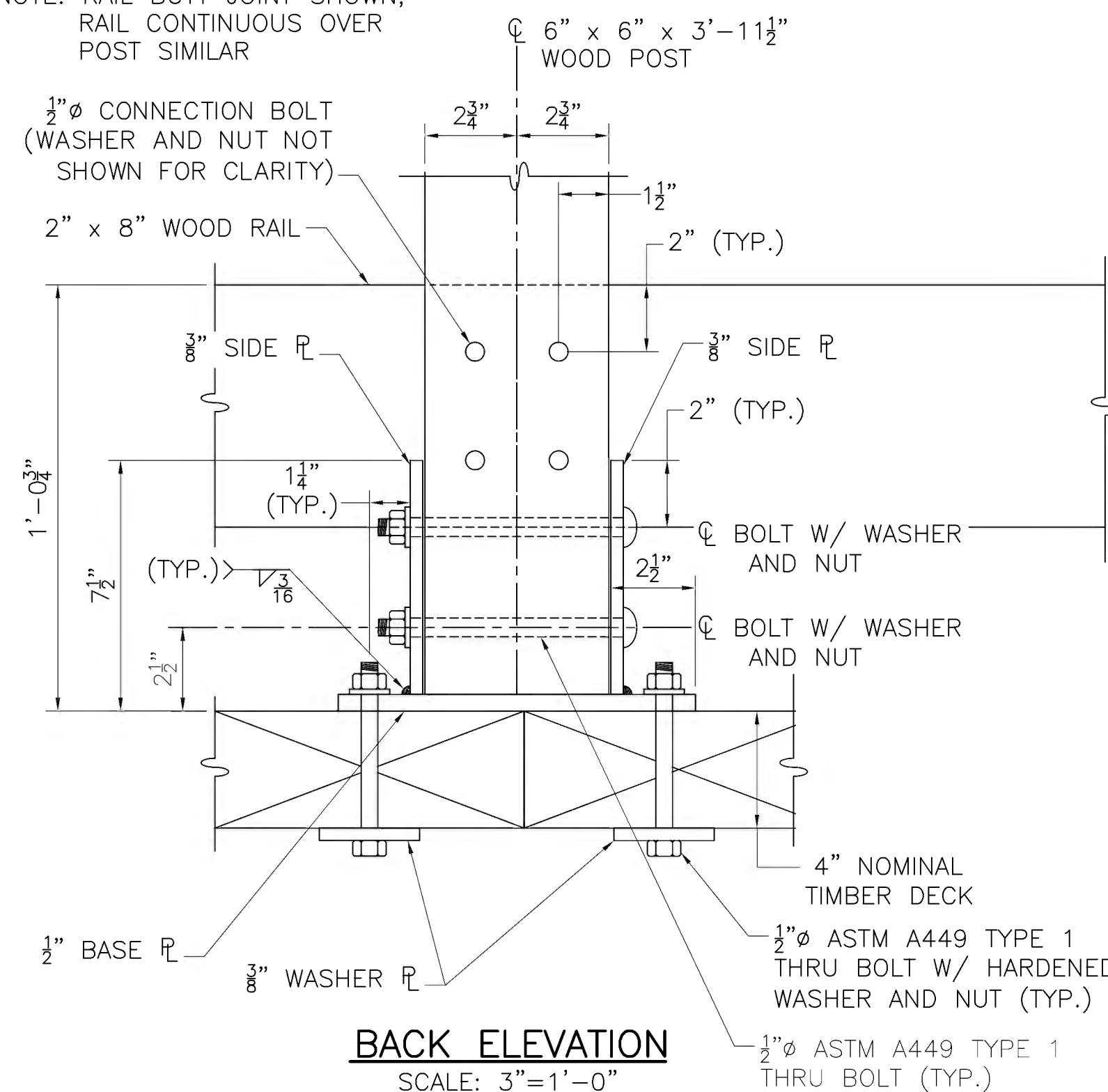

BACK ELEVATION

SCALE: 3"=1'-0"

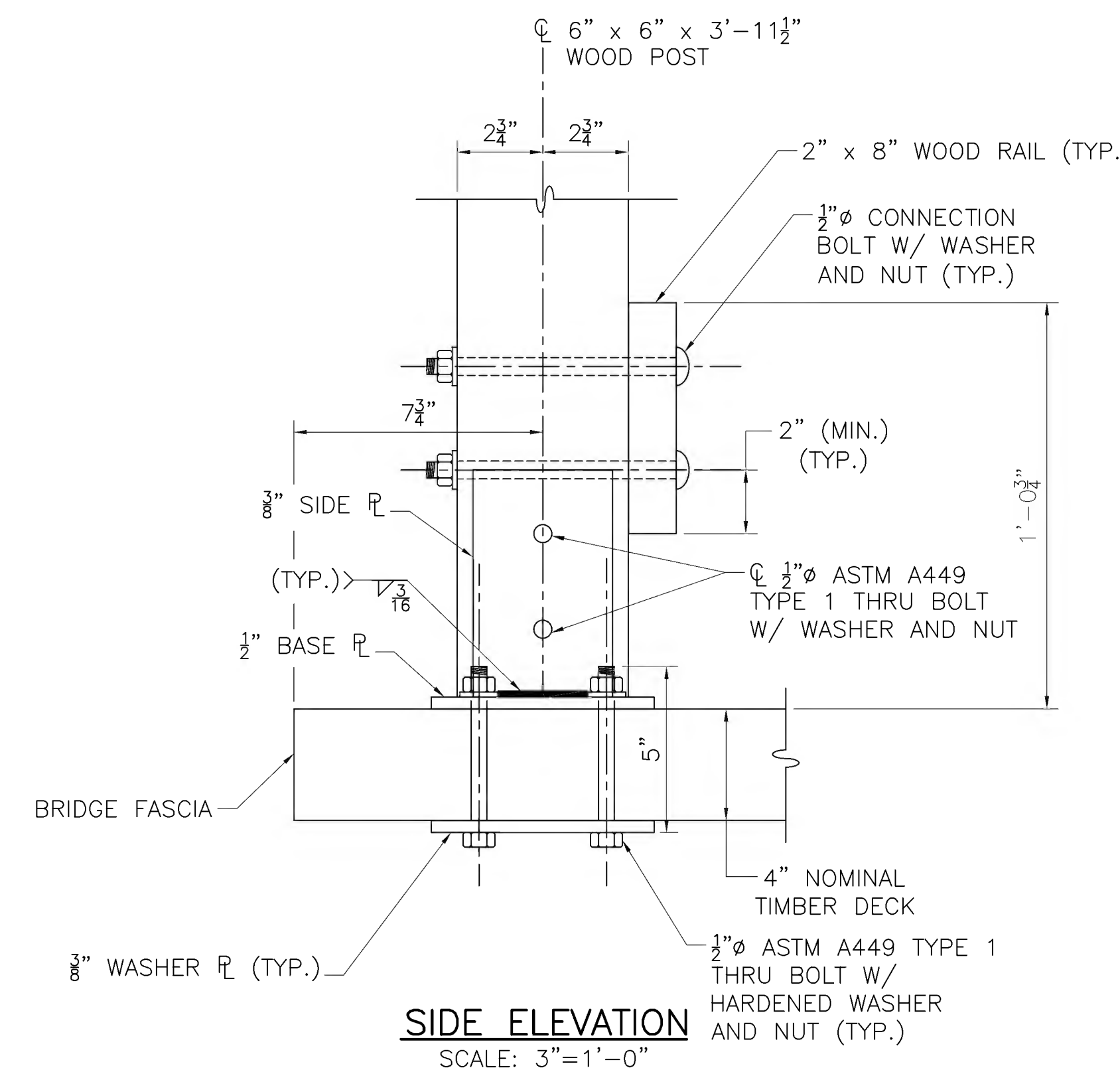

SIDE ELEVATION

SCALE: 3"=1'-0"

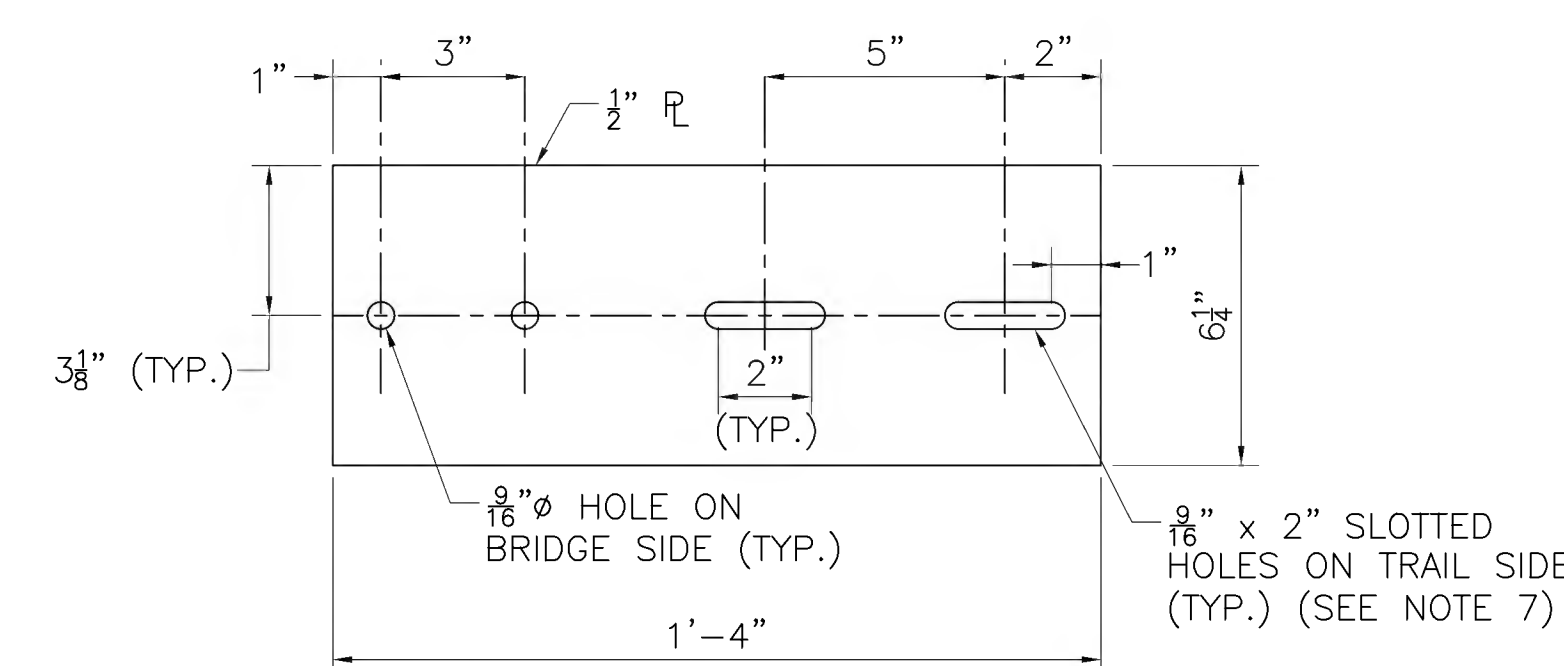

EXPANSION JOINT PLATE

SCALE: 3"=1'-0"

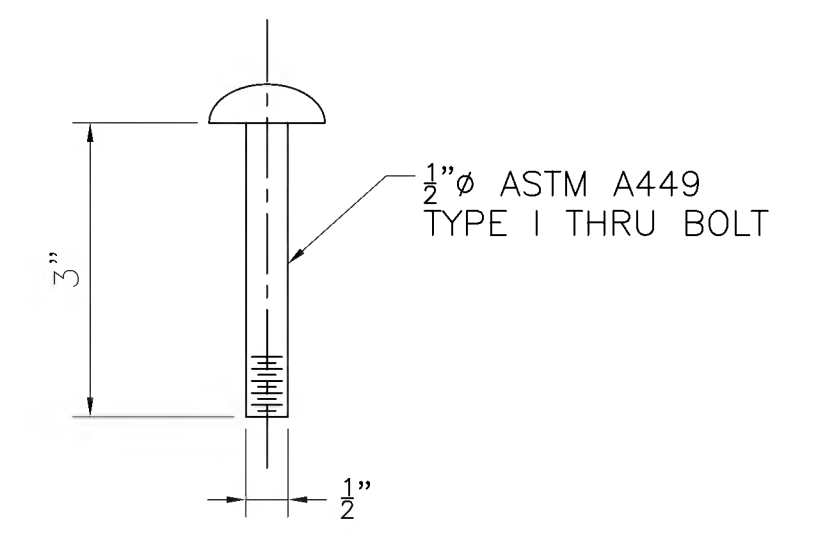

EXPANSION JOINT BOLTS

SCALE: 6"=1'-0"

MONTH DD, YYYY	ISSUED FOR CONSTRUCTION
DATE	DESCRIPTION
USE ONLY PRINTS OF LATEST DATE	

SUDBURY
BRUCE FREEMAN RAIL TRAIL OVER PANTRY BROOK

STATE	FED. AID PROJ. NO.	SHEET NO.	TOTAL SHEETS
MA	XXX-XXXX(XXX)X	235	319
PROJECT FILE NO.		608164	

KEY PLAN & PROFILE

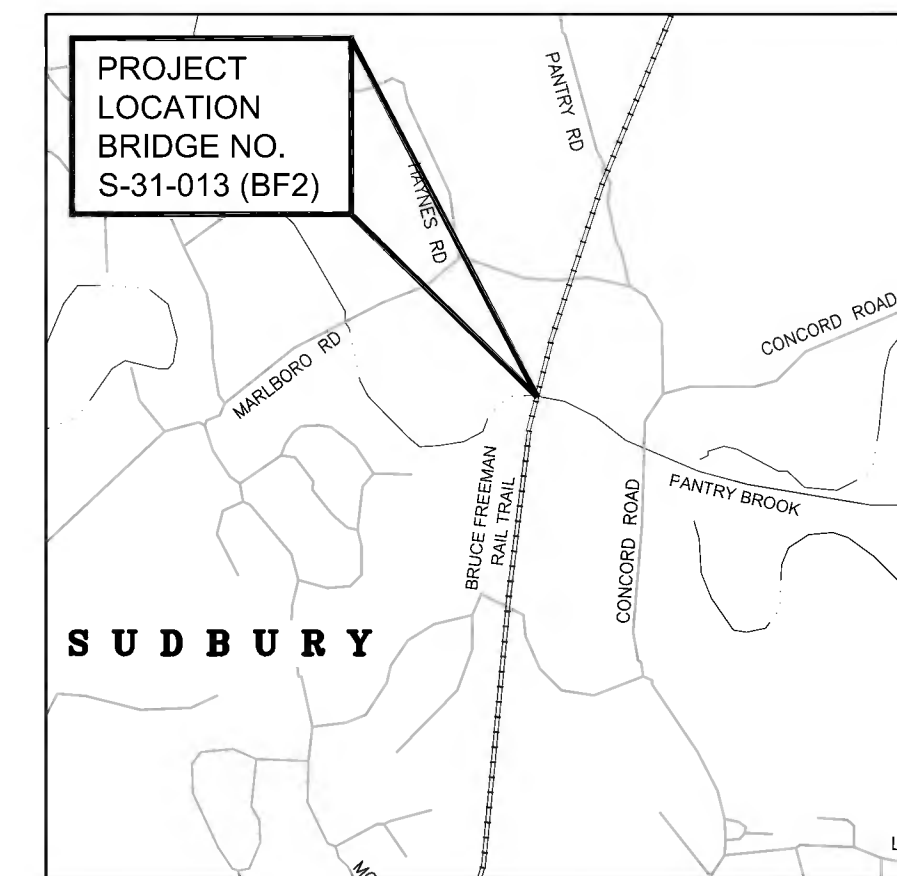

LOCUS PLAN
SCALE: 1" = 1200'

ESTIMATED QUANTITIES:
(NOT GUARANTEED)

ITEM NO.:	ITEM:	QUANTITY:	UNIT:
114.1	DEMOLITION OF SUPERSTRUCTURE OF BRIDGE NO. S-31-013	1	LS
140.	BRIDGE EXCAVATION	360	CY
143.	CHANNEL EXCAVATION	255	CY
151.2	GRAVEL BORROW FOR BACKFILLING STRUCTURES AND PIPES	270	CY
156.	CRUSHED STONE	85	TON
156.1	CRUSHED STONE FOR BRIDGE FOUNDATIONS	55	TON
665.	CHAIN LINK FENCE REMOVED AND STACKED	55	FT
690.	STONE MASONRY WALL REMOVED AND REBUILT IN CEMENT MORTAR	10	CY
690.91	MASONRY REPOINTING	10	SY
690.92	MASONRY REMOVED AND STOCKPILED	1	LS
698.4	GEOTEXTILE FABRIC FOR PERMANENT EROSION CONTROL	215	SY
707.4	PANTRY BROOK BLOCKS REMOVED AND RELOCATED	1	LS
767.78	COMPOSTED MULCH OVER MODIFIED ROCK	120	SY
983.	DUMPED RIPRAP	60	TON
986.	MODIFIED ROCKFILL	145	TON
991.2	CONTROL OF WATER - STRUCTURE NO. S-31-013	1	LS
995.01	BRIDGE STRUCTURE, BRIDGE NO. S-31-013	1	LS

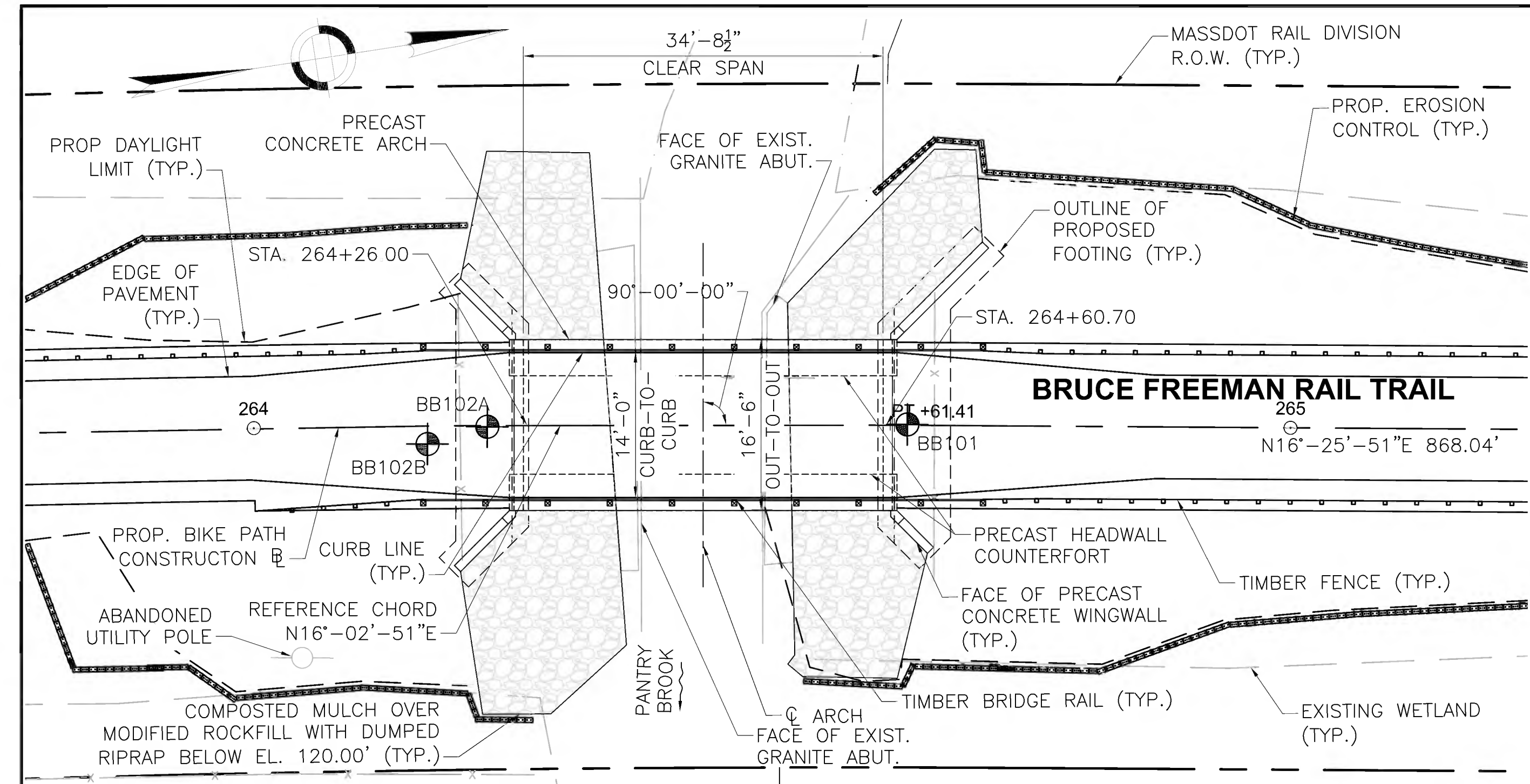

KEY PLAN
SCALE: 1" = 10'-0"

CURVE DATA

PI = 261+81.23
Δ = 11°-56'-04.85"
R = 2700.00
T = 282.23
L = 562.41
E = 14.71

INDEX

SHEET NO.	DESCRIPTION
1	KEY PLAN AND PROFILE
2	GENERAL NOTES
3-4	BORING LOGS
5	GENERAL PLAN AND ELEVATION
6	EARTHWORK DETAILS
7	TYPICAL SECTIONS AND ELEVATIONS
8	FOUNDATION PLAN AND DETAILS
9	PRECAST ARCH DETAILS AND NOTES
10	TIMBER BRIDGE RAIL DETAILS

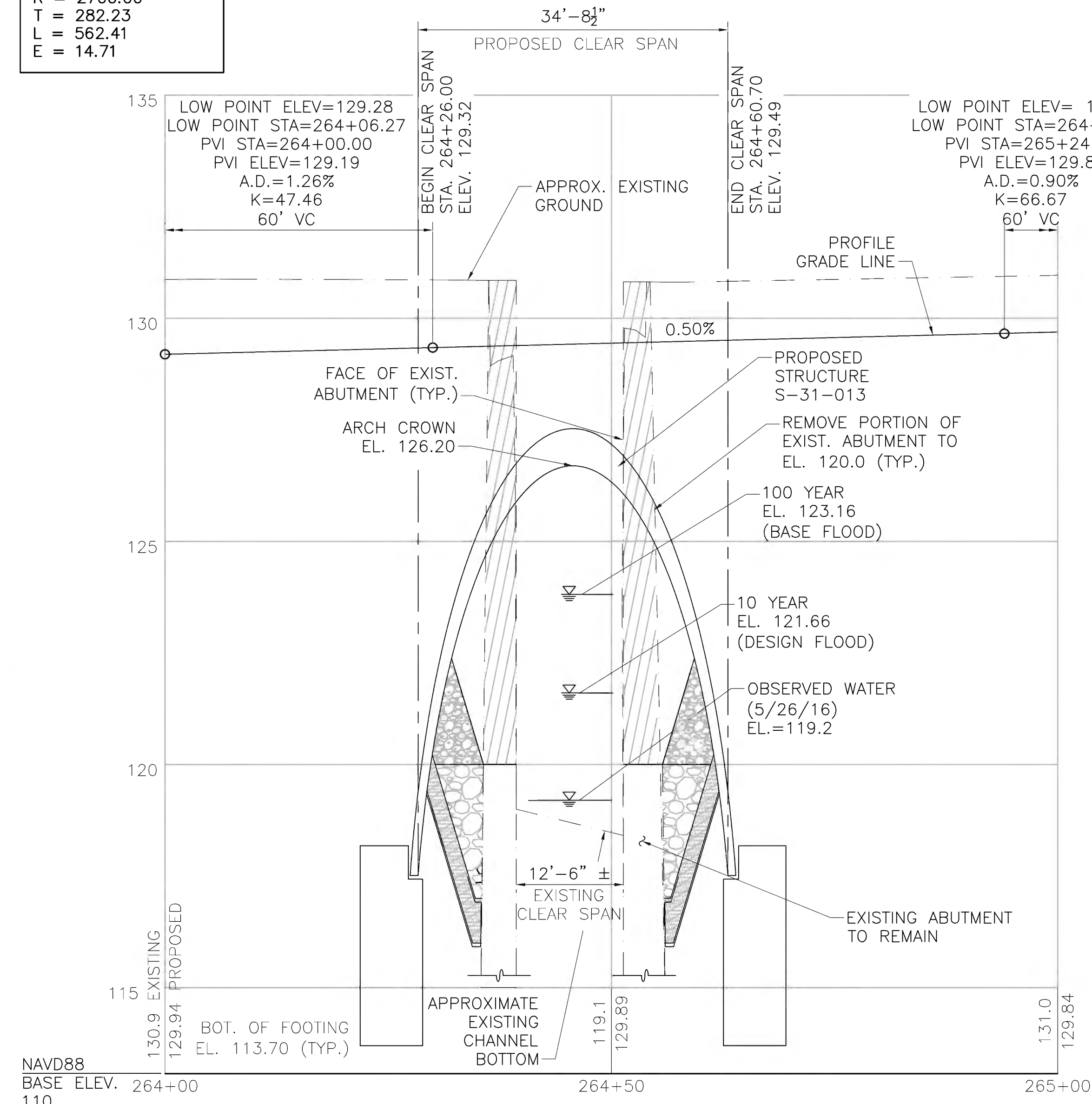

PROFILE ALONG BIKE PATH
HORIZONTAL SCALE: 1" = 10'-0"
VERTICAL SCALE: 1" = 2'-0"

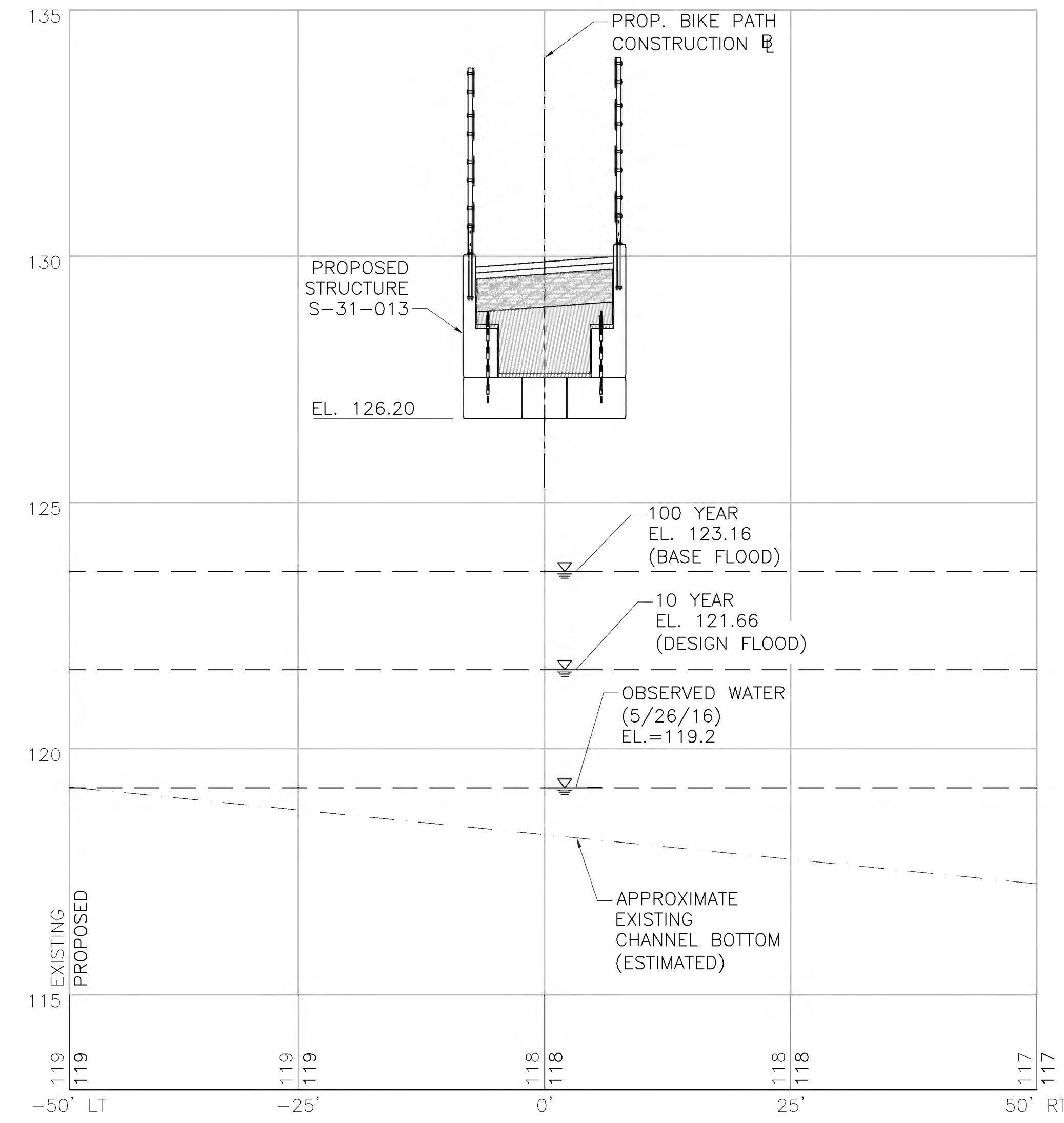

PROFILE ALONG PANTRY BROOK
HORIZONTAL SCALE: 1" = 10'-0"
VERTICAL SCALE: 1" = 2'-0"

P.E. STAMP SIGNATURE FUSS & O'NEILL 1550 MAIN STREET, SUITE 400 SPRINGFIELD, MA 01103 413.452.0445 www.fando.com	MONTH DD, YYYY ISSUED FOR CONSTRUCTION
	CHIEF ENGINEER

PROPOSED BRIDGE
SUDBURY
 BRUCE FREEMAN RAIL TRAIL OVER PANTRY BROOK
 MASSACHUSETTS DEPARTMENT OF TRANSPORTATION
 HIGHWAY DIVISION
 10 PARK PLAZA BOSTON, MASS

608164_BR(S-31-013)FIRST SHEET.DWG
 18-January-2022 2:43 PM
 2nd Structural Submitter (S2)

**SUDBURY
BRUCE FREEMAN RAIL TRAIL OVER PANTRY BROOK**

STATE	FED. AID PROJ. NO.	SHEET NO.	TOTAL SHEETS
MA	XXX-XXXX(XXX)X	236	319
PROJECT FILE NO.		608164	

GENERAL NOTES

GENERAL NOTES:

DESIGN:

IN ACCORDANCE WITH THE 2020 AMERICAN ASSOCIATION OF STATE HIGHWAY AND TRANSPORTATION OFFICIALS LRFD BRIDGE DESIGN SPECIFICATIONS WITH CURRENT INTERIM SPECIFICATIONS THROUGH 2021 AND THE 2009 LRFD GUIDE SPECIFICATIONS FOR THE DESIGN OF PEDESTRIAN BRIDGES FOR H-10 VEHICULAR AND 90 PSF PEDESTRIAN LOADINGS.

MASSDOT BENCH MARK:

BM #37 LAG SCREW SET 2' UP 7" PINE
ELEV. = 133.50'

ELEVATIONS ARE BASED ON THE NORTH AMERICAN VERTICAL DATUM (NAVD) OF 1988.

DATE:

TO BE PLACED ON THE UPSTREAM AND DOWNSTREAM HEADWALL FACES. A DETAIL SHOWING SIZE AND CHARACTER OF NUMERALS WILL BE FURNISHED. THE DATE USED SHALL BE THE LATEST YEAR OF CONTRACT COMPLETION AS OF THE DATE THE FIRST HEADWALL IS CONSTRUCTED. BOTH HEADWALLS SHALL FEATURE THE SAME DATE.

SURVEY NOTEBOOKS:

SURVEY PERFORMED BY VANASSE HANGEN BRUSTLIN, INC. FIELD NOTEBOOKS SHALL BE OBTAINED FROM FUSS AND O'NEILL, INC., SPRINGFIELD, MA.

SCALES:

SCALES NOTED ON THE PLANS ARE NOT APPLICABLE TO REDUCED SIZE PRINTS. DIVIDE SCALES BY 2 FOR HALF-SIZE PRINTS (A3).

FOUNDATIONS:

FOUNDATIONS MAY BE ALTERED, IF NECESSARY, TO SUIT CONDITIONS ENCOUNTERED DURING CONSTRUCTION, WITH THE APPROVAL OF THE ENGINEER.

UNSUITABLE MATERIAL:

ALL UNSUITABLE MATERIAL SHALL BE REMOVED WITHIN THE LIMITS OF THE FOUNDATIONS OF THE STRUCTURE, AS DIRECTED BY THE ENGINEER.

EXISTING CONSTRUCTION:

DIMENSIONS SHOWN ARE TAKEN FROM SURVEY, VARIOUS FIELD MEASUREMENTS, AND GEOTECHNICAL EXPLORATION AND ARE NOT GUARANTEED. THE CONTRACTOR SHALL DETERMINE AND ESTABLISH ALL DIMENSIONS AND DETAILS NECESSARY FOR COMPLETION OF ALL WORK BY FIELD MEASUREMENT AND SURVEY. THE CONTRACTOR SHALL BE RESPONSIBLE AND NOT ORDER ANY MATERIAL OR COMMENCE ANY FABRICATION UNTIL HE HAS MADE THE REQUIRED MEASUREMENTS ON THE ACTUAL STRUCTURE AND THE EXTENT OF THE PROPOSED WORK HAS BEEN APPROVED BY THE ENGINEER. EXISTING BRIDGE PLANS ARE NOT AVAILABLE FOR REFERENCE.

CONCRETE:

5,000 PSI, 3/4 INCH, 685 HP CEMENT CONCRETE SHALL BE PROVIDED FOR ALL CONCRETE INCLUDING ARCH, HEADWALLS, WINGWALLS, AND FOOTINGS.

REINFORCEMENT:

REINFORCING STEEL SHALL CONFORM TO THE REQUIREMENTS OF AASHTO M 31 GRADE 60. UNLESS OTHERWISE NOTED ON THE CONSTRUCTION DRAWINGS, ALL BARS SHALL BE LAPPED AS FOLLOWS:

MODIFICATION CONDITION	#4 BARS	#5 BARS	#6 BARS
1. NONE	16"	19"	23"
2. 12" OF CONCRETE BELOW BAR	20"	25"	30"
3. EPOXY COATED BARS, COVER < 3d _b , OR CLEAR SPACING < 6d _b	23"	29"	34"
4. COATED BARS, ALL OTHER CASES	18"	23"	27"
5. CONDITION 2. AND 3.	26"	32"	39"
6. CONDITION 2. AND 4.	24"	30"	36"

ALL OTHER BARS SHOULD BE LAPPED AS SHOWN ON THE CONSTRUCTION DRAWINGS.

ALL REINFORCEMENT SHALL BE EPOXY COATED.

SECTION MARK:

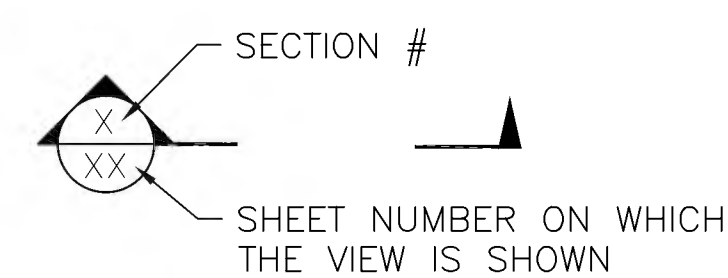

TRAFFIC DATA		
	ROADWAY OVER	ROADWAY UNDER
DESIGN YEAR	N/A	
AVERAGE DAILY TRAFFIC -- PRESENT	N/A	
AVERAGE DAILY TRAFFIC -- DESIGN YEAR	N/A	
DESIGN HOURLY VOLUME	N/A	
DIRECTIONAL DISTRIBUTION	N/A	
TRUCK PERCENTAGE -- AVERAGE DAY	N/A	
TRUCK PERCENTAGE -- PEAK HOUR	N/A	
DESIGN SPEED	18 MPH	
DIRECTIONAL DESIGN HOURLY VOLUME	N/A	

SEISMIC DESIGN CRITERIA	
DESIGN RETURN PERIOD:	1,000
DESIGN SPECTRA	
As	0.11
SDs	0.23
SD1	0.09
SITE CLASS	D
SEISMIC DESIGN CATEGORY (SDC)	A

HYDRAULIC DESIGN DATA	
DRAINAGE AREA (SQ. MILES)	2.5
DESIGN FLOOD DISCHARGE (C.F.S.)	155
DESIGN FLOOD FREQUENCY (YEARS)	10
DESIGN FLOOD VELOCITY (F.P.S.)	2.88
DESIGN FLOOD ELEVATION (FEET, NAVD)	121.66

BASE (100-YEAR) FLOOD DATA	
BASE FLOOD DISCHARGE (C.F.S.)	240
BASE FLOOD ELEVATION (FEET, NAVD)	123.16

DESIGN AND CHECK SCOUR DATA	
DESIGN SCOUR FLOOD EVENT RETURN FREQUENCY (YEARS)	25
DESIGN FLOOD ABUTMENT SCOUR DEPTH (FEET)	0.6
DESIGN FLOOD PIER SCOUR DEPTH (FEET)	N/A
CHECK SCOUR FLOOD EVENT RETURN FREQUENCY (YEARS)	50
CHECK FLOOD ABUTMENT SCOUR DEPTH (FEET)	0.7
CHECK FLOOD PIER SCOUR DEPTH (FEET)	N/A

FLOOD OF RECORD	
DISCHARGE (C.F.S.)	N/A
FREQUENCY (IF KNOWN, YEARS)	N/A
MAXIMUM ELEVATION (FEET, NAVD)	N/A
DATE (MM/YYYY)	N/A
HISTORY OF ICE FLOES	N/A
EVIDENCE OF SCOUR AND EROSION	YES

MONTH DD, YYYY	ISSUED FOR CONSTRUCTION
DATE	DESCRIPTION
USE ONLY PRINTS OF LATEST DATE	

STATE	FED. AID PROJ. NO.	SHEET NO.	TOTAL SHEETS
MA	XXX-XXXX(XXX)X	238	319
PROJECT FILE NO.		608164	

BORING LOGS

BORING NOTES:
SEE SHEET 3 FOR BORING NOTES.

LOG OF TEST BORING

JACOBS		PROJECT Bruce Freeman Rail Trail	BORING NO. BB-102A
LOCATION Sudbury, MA		SHEET 1 OF 1	
OWNER MASSDOT		ELEVATION 131	
JOB NUMBER E2X81800		CONTRACTOR NEBC	
INSPECTOR S. Ramesh	DRILLER B. Cross	ELEVATION 131	
METHOD OF DRILLING Split Spoon Sample		DRILL RIG Mobile B-53	
DATE/TIME 08-20-2019 / 1:36 pm		DATUM NAVD 88	
DEPTH (ft) 11.5		REMARKS Upon Completion (Casing pulled)	
DATE START 8/20/19		COORD E 681121	
DATE END 8/20/19		DATE END 8/20/19	

ELEV. (ft)	DEPTH (ft)	SAMPLE DATA	N-VALUE	SAMPLE NO.	DEPTH INTERVAL (ft)	PEN/REC (in/ft)	PID (ppm)	LAYER NAME	SOIL AND ROCK DESCRIPTION	NOTES
130	2	4		10	0-2	24/17		FILL	S1: (0-12") Dry, black, medium SAND, trace Gravel, roots (topsoil). (12-17") Dry, brown, fine to medium SAND, trace Silt.	
125	4	5		11	2-4	24/15		FILL	S2: Dry, medium dense, brown, fine to medium SAND, little Silt, trace Gravel.	
120	6	5		6	4-6	24/9		FILL	S3: Wet, loose, brown, fine SAND, some Silt, trace Gravel.	
115	11	3		11	6-8	24/10		FILL	S4: Wet, medium dense, brown, fine SAND and SILT.	
110	12	6		12	8-10	24/5		FILL	S5: Wet, medium dense, fine to coarse SAND, some Silt, trace Gravel.	
105	10	1		4	10-12	24/4		PEAT	S6: Wet, medium stiff, brown, SILT, some fine to medium Sand, trace Clay, trace Gravel.	
100	5	1		5	12-14	24/23		PEAT	S7: Wet, blackish brown, fine grained PEAT.	
95	19	8		19	14-16	24/19		SAND	S8: Wet, medium dense, brownish gray, medium to coarse SAND, some Silt.	
90	41	11		19	16-18	24/15		SAND	S9: Wet, dense, brown, medium to coarse SAND, trace Silt, trace fine Gravel.	
85	29	16		19	18-20	24/19		SAND	S10: Wet, medium dense, grayish brown, medium to coarse SAND, little Silt.	
80	33	15		19	24-26	24/5		SILT	S11: Wet, hard, gray SILT, little fine Sand, little fine Gravel.	1
75									Bottom of Borehole at 26 feet.	2

Page 1: 0-35 feet. Each subsequent page displays 40 feet.

1. Boring terminated at 26' due to an obstruction.
2. Boring offset 6' south and continued. See boring log BB-102B.

LOG OF TEST BORING

JACOBS		PROJECT Bruce Freeman Rail Trail	BORING NO. BB-102B
LOCATION Sudbury, MA		SHEET 1 OF 2	
OWNER MASSDOT		ELEVATION 131	
JOB NUMBER E2X81800		CONTRACTOR NEBC	
INSPECTOR S. Ramesh	DRILLER B. Cross	ELEVATION 131	
METHOD OF DRILLING Wash Boring w/ 3" Casing		DRILL RIG Mobile B-53	
DATE/TIME 08-21-2019 / 8:34 am		DATUM NAVD 88	
DEPTH (ft) 10.8		REMARKS During Drilling (In Casing)	
DATE START 08-22-2019 / 9:02 am		COORD E 681121	
DATE END 08-23-2019 / 9:06 am		DATE END 8/23/19	

ELEV. (ft)	DEPTH (ft)	SAMPLE DATA	N-VALUE	SAMPLE NO.	DEPTH INTERVAL (ft)	PEN/REC (in/ft)	PID (ppm)	LAYER NAME	SOIL AND ROCK DESCRIPTION	NOTES
130									Drill through.	
105	55/4"	55/4"		12	29.5 - 29.8	4/3			S12: Wet, very dense, gray, fine to coarse GRAVEL, trace coarse Sand.	
100	24	52		13	34 - 36	24/10			S13: Wet, very dense, gray GRAVEL and SAND, little Silt.	

Page 1: 0-35 feet. Each subsequent page displays 40 feet.

LOG OF TEST BORING

JACOBS		PROJECT Bruce Freeman Rail Trail	BORING NO. BB-102B
LOCATION Sudbury, MA		SHEET 2 OF 2	
OWNER MASSDOT		ELEVATION 131	
JOB NUMBER E2X81800		CONTRACTOR NEBC	
INSPECTOR S. Ramesh	DRILLER B. Cross	ELEVATION 131	
METHOD OF DRILLING Wash Boring w/ 4" Casing		DRILL RIG Mobile B-53	
DATE/TIME 08-20-2019 / 1:36 pm		DATUM NAVD 88	
DEPTH (ft) 11.5		REMARKS Upon Completion (Casing pulled)	
DATE START 8/20/19		COORD E 681121	
DATE END 8/20/19		DATE END 8/23/19	

ELEV. (ft)	DEPTH (ft)	SAMPLE DATA	N-VALUE	SAMPLE NO.	DEPTH INTERVAL (ft)	PEN/REC (in/ft)	PID (ppm)	LAYER NAME	SOIL AND ROCK DESCRIPTION	NOTES
95	31	21		33				GRAVEL	S14: Wet, very dense, gray, fine to coarse GRAVEL, little coarse Sand, trace Silt.	
90	30	53/4"	53/4"	S14	39 - 39.8	10/5		GRAVEL		
85	18	25		59	44 - 46	24/21		SILT	S15: Wet, hard, gray SILT, some Clay, trace fine Sand, trace Gravel.	
80	16	37		82	49 - 50.8	22/22		SILT	S16: Wet, hard, gray SILT, some Clay, trace fine to coarse Sand, little Gravel.	
75								GRANODIORITE	RC-1: Coring time: 4.5, 5, 4.5, 11 (mins/ft) Wet, gray, pink grained, moderately to severely weathered, coarse grained GRANODIORITE.	
70								GRANODIORITE	RC-2: Coring time: 6, 5, 3.5, 2.5, 2 (mins/ft) Similar to RC-1.	
65								GRANODIORITE	RC-3: Coring time: 2, 3.5 (mins/ft) Similar to RC-1.	
60									Bottom of Borehole at 62.8 feet.	

Page 1: 0-35 feet. Each subsequent page displays 40 feet.

MONTH DD, YYYY	ISSUED FOR CONSTRUCTION
DATE	DESCRIPTION
USE ONLY PRINTS OF LATEST DATE	

608164_BRC34(S-31-013)BORINGS.DWG 18-January-2022 2:43 PM 2nd Structural Submittal (S2)

**SUDBURY
BRUCE FREEMAN RAIL TRAIL OVER PANTRY BROOK**

STATE	FED. AID PROJ. NO.	SHEET NO.	TOTAL SHEETS
MA	XXX-XXXX(XXX)X	239	319
PROJECT FILE NO.		608164	

GENERAL PLAN & ELEVATION

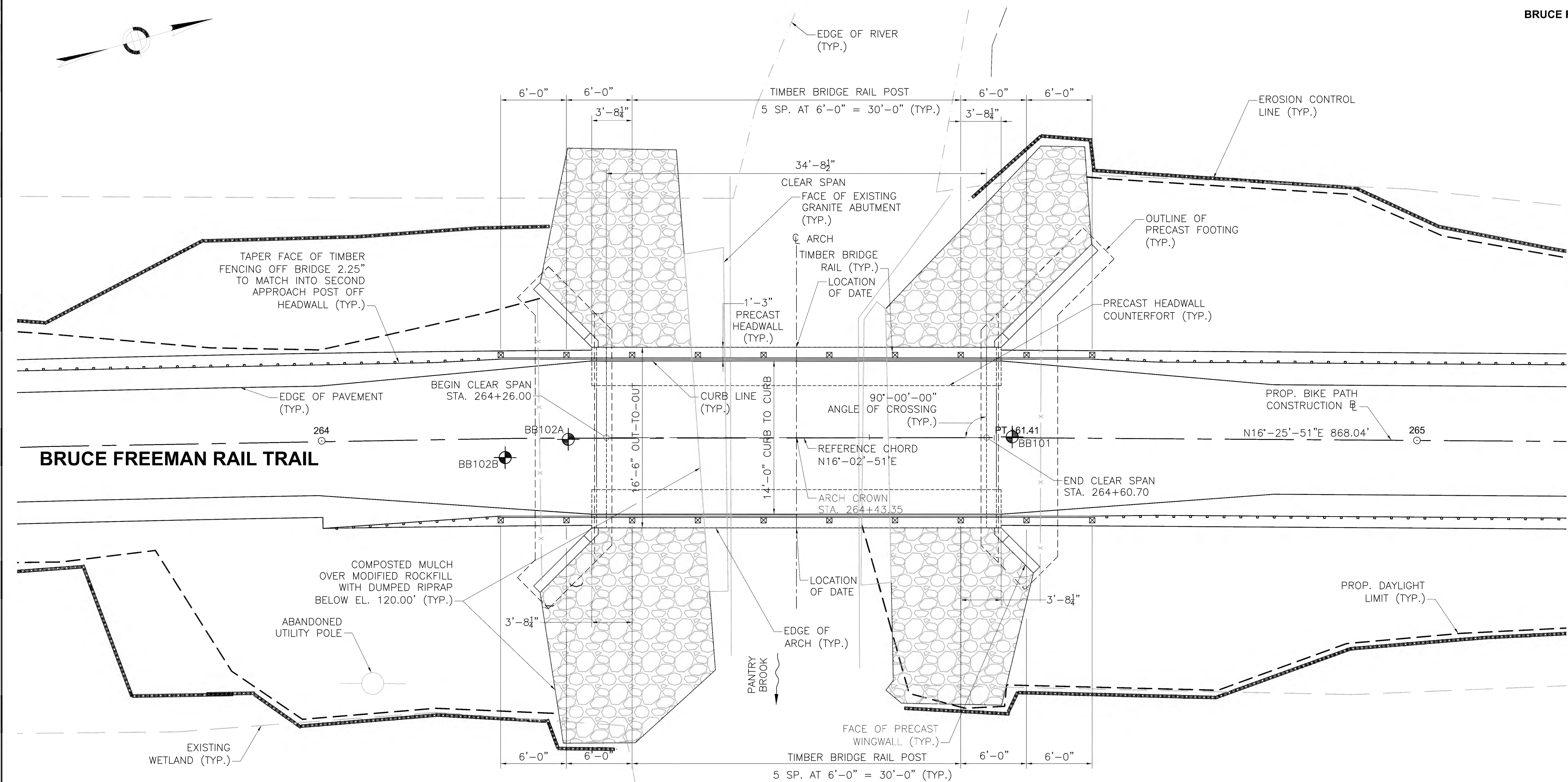

GENERAL PLAN

SCALE: 1" = 5'-0"

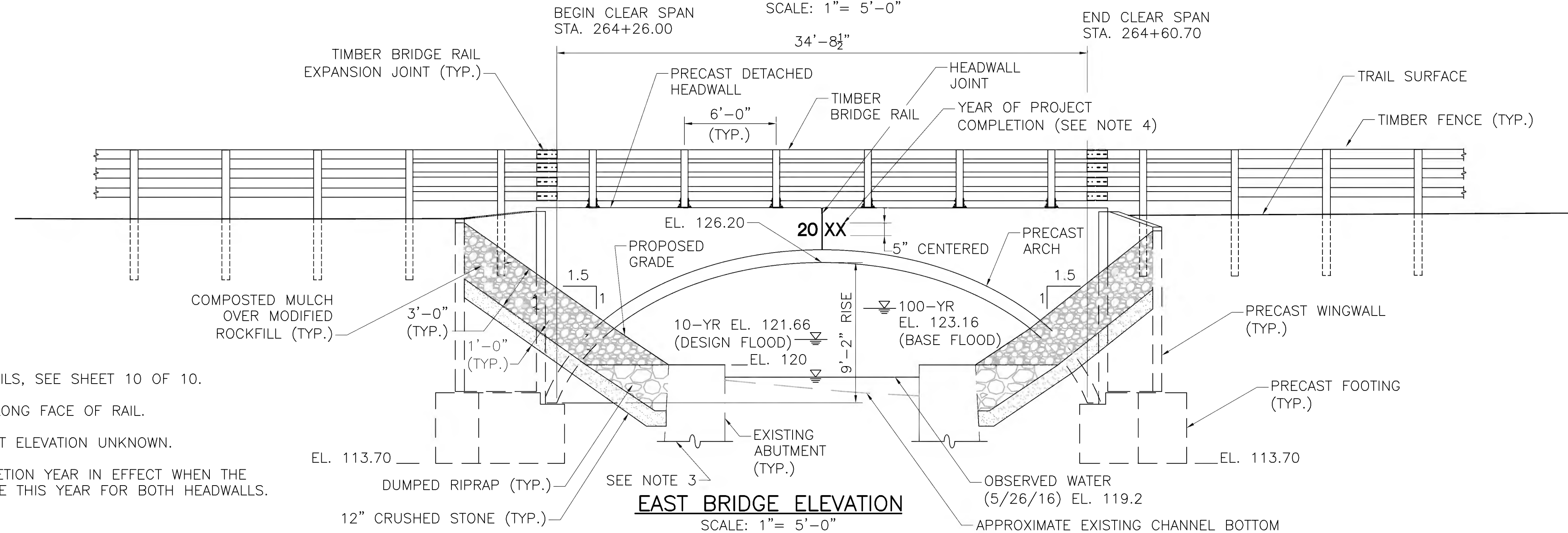

EAST BRIDGE ELEVATION

SCALE: 1" = 5'-0"

- NOTES:**
- FOR TIMBER BRIDGE RAIL DETAILS, SEE SHEET 10 OF 10.
 - RAIL POSTS ARE MEASURED ALONG FACE OF RAIL.
 - BOTTOM OF EXISTING ABUTMENT ELEVATION UNKNOWN.
 - USE LATEST CONTRACT COMPLETION YEAR IN EFFECT WHEN THE FIRST HEADWALL IS CAST. USE THIS YEAR FOR BOTH HEADWALLS.

MONTH DD, YYYY	ISSUED FOR CONSTRUCTION
DATE	DESCRIPTION
USE ONLY PRINTS OF LATEST DATE	

608164_BRF(S-31-013)GENPLAN.DWG Plotted on 18-Feb-2022 2:44 PM 2nd Structural Submittal (S2) 18-January-2022

STATE	FED. AID PROJ. NO.	SHEET NO.	TOTAL SHEETS
MA	XXX-XXXX(XXX)X	240	319
PROJECT FILE NO.		608164	

EARTHWORK DETAILS

EXISTING ABUTMENT REPAIR NOTES:

- REMOVE TOPS OF EXISTING STONE MASONRY ABUTMENTS TO ELEVATION 120' OR TO THE NEAREST LONGITUDINAL STONE JOINT, PROVIDED THE JOINT LIES ABOVE THE RIVERBED OR AS DIRECTED BY THE ENGINEER. THE COST TO REMOVE THE EXISTING STONES SHALL BE INCLUDED IN ITEM 690.92, "MASONRY REMOVED AND STOCKPILED". SEVEN (7) OF THESE GRANITE BLOCKS SHALL BE SET ASIDE FOR RE-USE AS BENCHES AND HISTORIC DISPLAY ALONG THE TRAIL. REMOVAL AND RESETTING OF THESE 7 BLOCKS SHALL BE PAID FOR SEPARATELY UNDER ITEM 707.4, "PANTRY BROOK BLOCKS REMOVED AND RELOCATED". SEE SPECIAL PROVISIONS. ALL REMAINING STONES ARE TO BE DELIVERED TO THE TOWN OF SUDBURY PUBLIC WORKS DIVISION.
- THE SOUTH EXISTING STONE MASONRY ABUTMENT HAS PARTIALLY COLLAPSED. THE CONTRACTOR SHALL REBUILD ANY COLLAPSED PORTIONS OF THE EXISTING WALL ALONG THE LENGTH OF THE ABUTMENT AND WINGWALLS BELOW THE LIMITS OF REMOVAL. THE COST TO REBUILD THE WALL AS REQUIRED SHALL BE INCLUDED IN ITEM 690, "STONE MASONRY WALL REMOVED AND REBUILT IN CEMENT MORTAR".
- REPOINTING OF THE EXISTING STONE MASONRY ABUTMENTS SHALL BE REQUIRED AFTER THE TOP OF THE EXISTING ABUTMENTS HAVE BEEN REMOVED BUT PRIOR TO EXCAVATION OPERATIONS. THE COST TO REPOINT SHALL BE INCLUDED IN ITEM 690.91, "MASONRY REPOINTING".
- ANY WATER CONTROL REQUIRED TO REMOVE, REPAIR, REBUILD, SHORE, OR REPOINT THE EXISTING ABUTMENTS SHALL BE INCLUDED UNDER ITEM 991.2, "CONTROL OF WATER - STRUCTURE NO. S-31-013".
- THE CONFIGURATION OF THE EXISTING ABUTMENT STONE WALLS AND THE ELEVATION OF THE BOTTOM OF THE EXISTING ABUTMENTS SHOWN ON THE PLANS ARE APPROXIMATE. THE CONTRACTOR SHALL ENSURE THE EXISTING ABUTMENT STONE WALLS ARE NOT UNDERMINED OR IN ANY WAY COMPROMISED DURING EXCAVATION OPERATIONS. TEMPORARY SHORING OF THE EXISTING ABUTMENT WALLS MAY BE REQUIRED TO COMPLETE EXCAVATION OPERATIONS. THE COST FOR TEMPORARY SHORING SHALL BE INCLUDED IN ITEM 995.01, "BRIDGE STRUCTURE, BRIDGE NO. S-31-013".

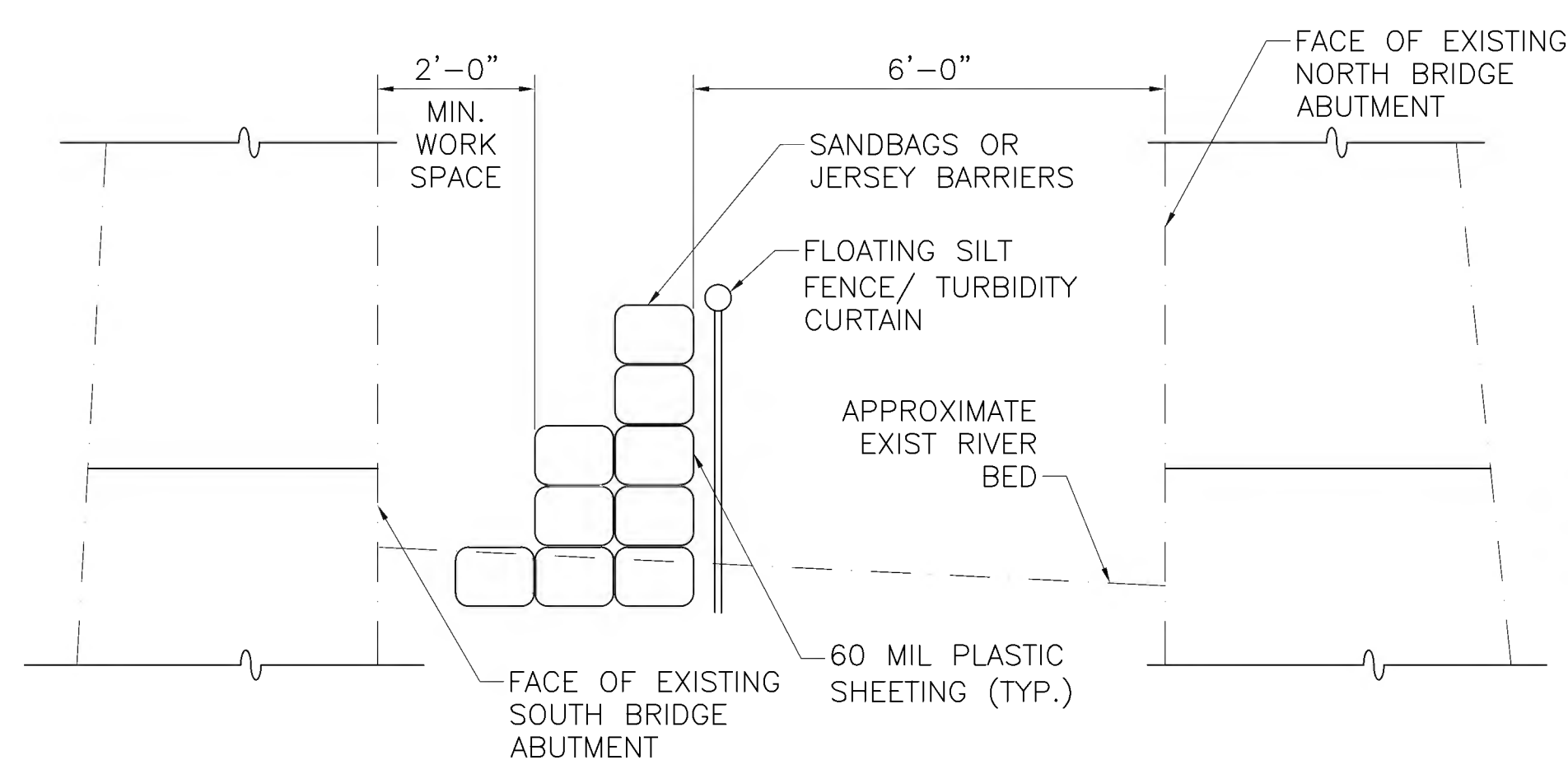

SUGGESTED WATER CONTROL PLAN
SCALE: 1"=1'-0"

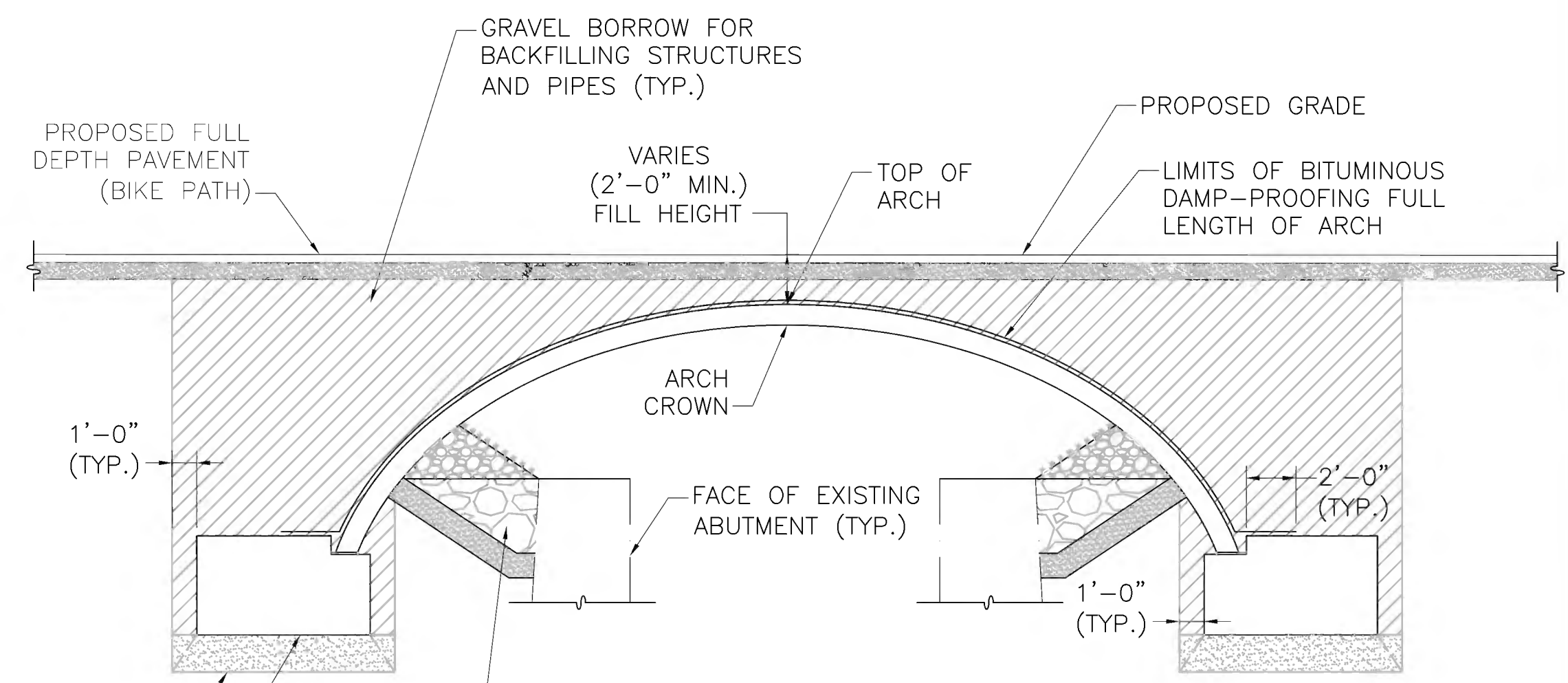

ARCH BACKFILL DETAIL
SCALE: 3/16"=1'-0"

NOTES:

- WORK IN THE WATER SHALL BE PERFORMED DURING LOW FLOW SEASON AS DEFINED IN THE SPECIAL PROVISION FOR ITEM 991.2 AND THE FLOW SHALL BE MAINTAINED THROUGH THE USE OF TEMPORARY WATER CONTROL.
- THE CONTRACTOR SHALL BE RESPONSIBLE FOR SIZING THE BARRIER TO HANDLE THE RIVER FLOW. THE BARRIER SHALL BE OF ADEQUATE SIZE TO DELIVER THE WATER AT THE DISCHARGE END TO THE RIVER WITHOUT DISTURBING THE EXISTING BANKS OR RIVERBED FLOW. THE BARRIER HEIGHT SHALL BE SIZED TO MAINTAIN 1' OF FREEBOARD OVER THE 10-YEAR FLOOD.
- IN THE EVENT OF HIGH FLOW RATES, THE CONTRACTOR SHALL BE RESPONSIBLE TO DEVELOP AND IMPLEMENT A REASONABLE MEANS NECESSARY TO HANDLE THE ADDITIONAL FLOWS TO PROTECT THE SURROUNDING AREA, AS APPROVED BY THE ENGINEER AND SHALL BE INCIDENTAL TO ITEM 991.2, "CONTROL OF WATER - STRUCTURE NO. S-31-013".
- WATER CONTROL SHALL BE PHASED. EXISTING CLEAR SPAN IS NOT SUFFICIENT TO ACCOMMODATE SAND BAGS IN FRONT OF BOTH ABUTMENTS SIMULTANEOUSLY WHILE ALLOWING ADEQUATE FLOW.

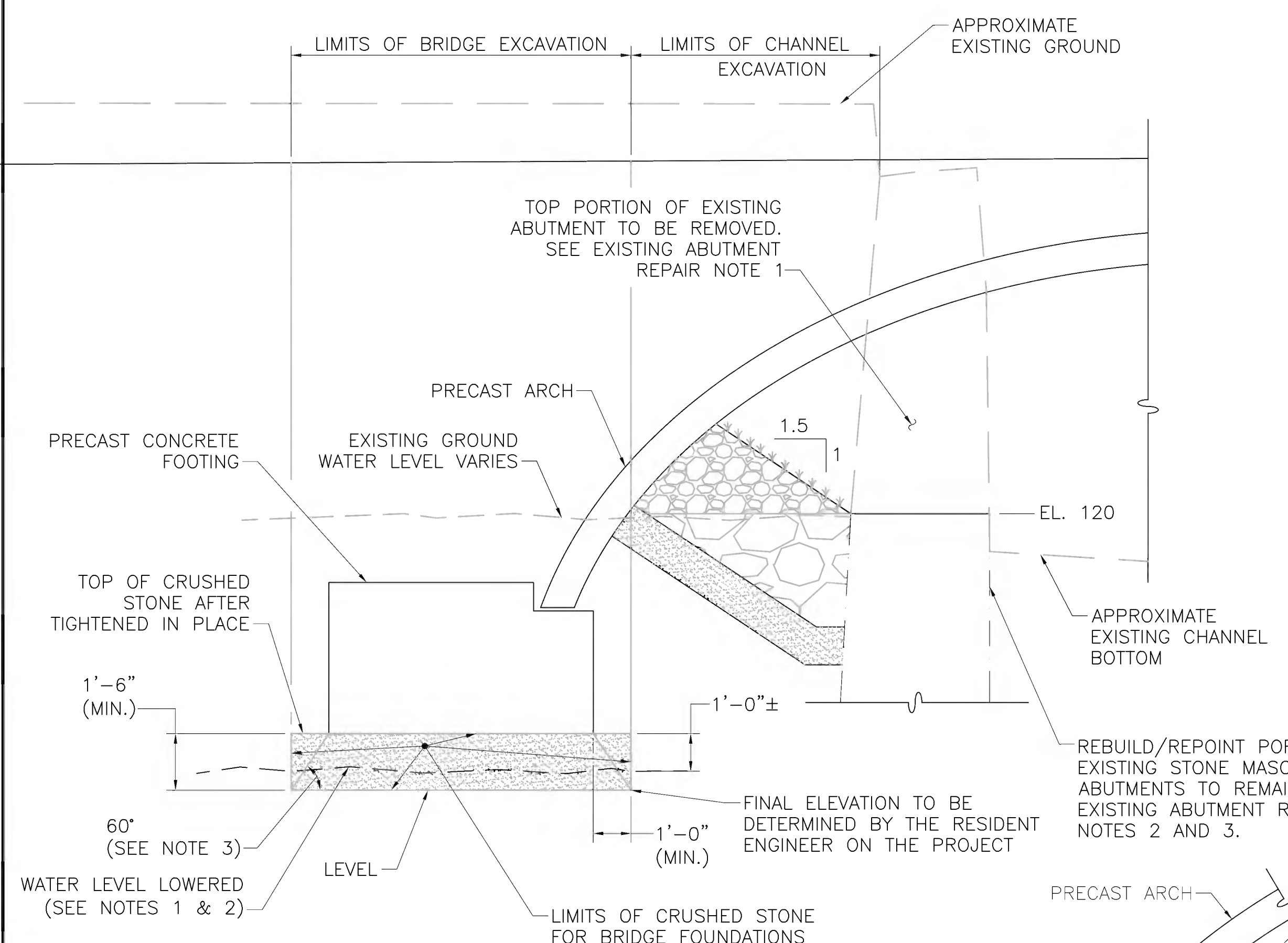

LIMITS OF CRUSHED STONE FOR BRIDGE FOUNDATIONS
SCALE: 3/8"=1'-0"

NOTES:

- LOWER WATER LEVEL AS MUCH AS POSSIBLE WITHOUT DISTURBING THE GRANULAR SOIL (SIDES AND BOTTOM) AND TIGHTEN THE CRUSHED STONE IN PLACE (SEE STANDARD SPEC).
- WATER CONTROL REQUIREMENTS:
 - THE CONTRACTOR SHALL SUBMIT THE WATER CONTROL PLAN FOR APPROVAL PRIOR TO REMOVAL OF THE TOPS OF THE EXISTING ABUTMENTS AND WINGWALLS AND PLACEMENT OF THE PRECAST ARCH FOOTINGS.
 - EXCAVATED FOOTING AREA SHALL CONTINUE TO BE DEWATERED UNTIL THE PRECAST CONCRETE FOOTINGS ARE FULLY INSTALLED.
 - DUMPED RIPRAP, MODIFIED ROCK FILL, AND COMPOSTED MULCH SHALL BE PLACED IN THE DRY AFTER DEWATERING ALL AREAS.
- SUPPORT OF EXCAVATION MAY BE REQUIRED BEHIND THE PROPOSED FOOTING TO COMPLETE EXCAVATION OPERATIONS. THE COST FOR SUPPORT OF EXCAVATION SHALL BE INCLUDED IN ITEM 995.01, "BRIDGE STRUCTURE, BRIDGE NO. S-31-013".

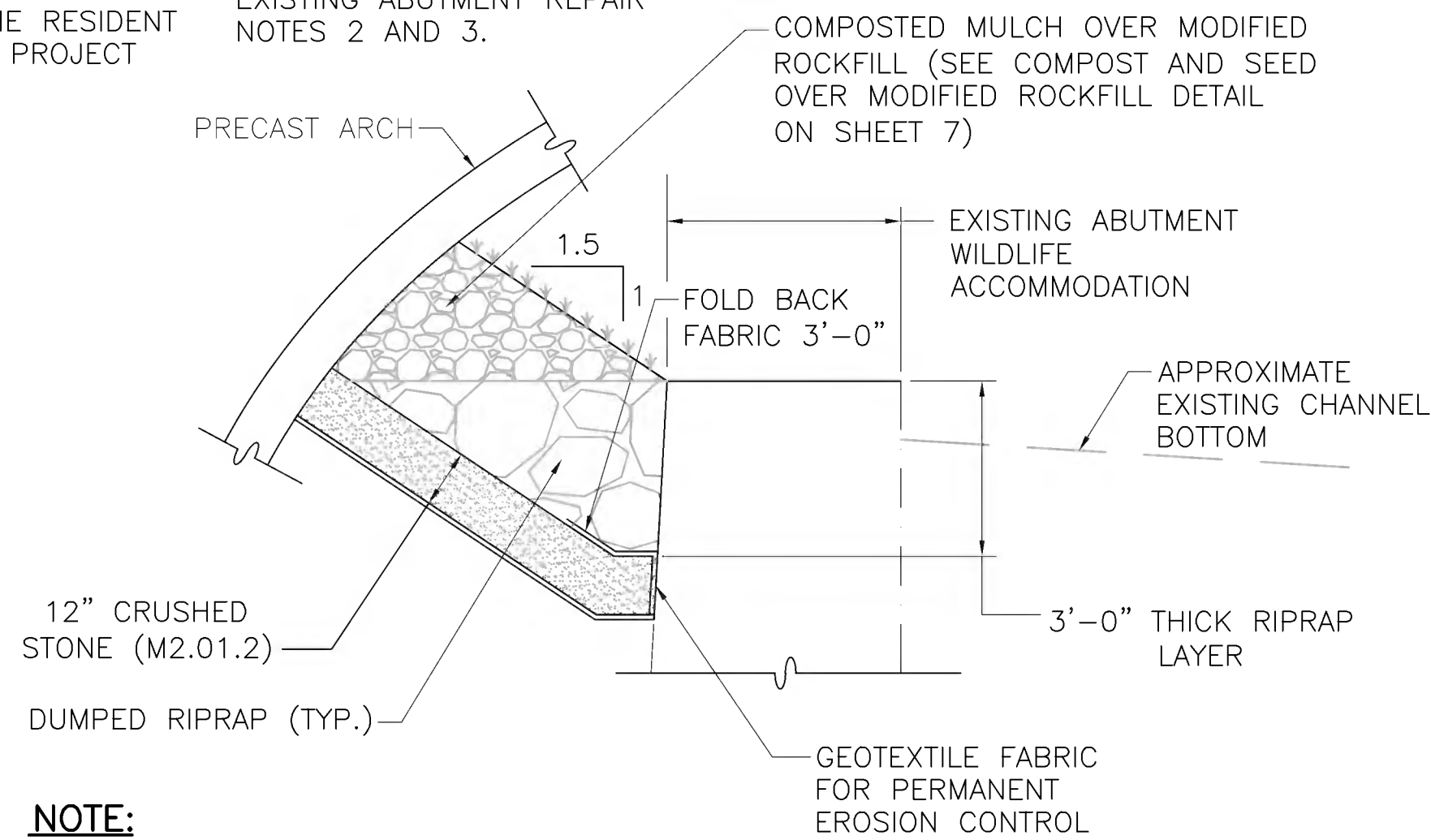

RIPRAP DETAIL
SCALE: 3/8"=1'-0"

NOTE:

EXCAVATION BETWEEN THE BACK FACE OF THE EXISTING ABUTMENT TO THE VERTICAL LIMIT OF EXCAVATION FOR CRUSHED STONE FOR BRIDGE FOUNDATIONS AND DOWN TO THE BOTTOM OF CRUSHED STONE (M2.01.2) SHALL BE PAID FOR UNDER ITEM 143, "CHANNEL EXCAVATION".

NOTES:

- 4" Ø WEEP HOLES 10'-0" O.C. LOCATED 12" ABOVE THE HEEL OF THE FOOTING SLOPING 1" PER FOOT TOWARDS THE FRONT FACE. PROVIDE 1 CUBIC YARD OF CRUSHED STONE AT EACH END OF WEEP HOLE. SEE SHEET 9 FOR WEEP HOLE LAYOUT.
- SEE LIMITS OF CRUSHED STONE FOR BRIDGE FOUNDATIONS DETAIL FOR WINGWALL FOOTING REQUIREMENTS.
- SEE RIPRAP DETAIL AND COMPOST AND SEED OVER MODIFIED ROCKFILL DETAIL ON SHEET 7 FOR ROCKFILL AT FACE OF WINGWALL REQUIREMENTS.
- ALL PRECAST CONCRETE SHALL BE 5,000 PSI, 3/4 INCH, 685 HP CEMENT CONCRETE.
- CONTRACTOR SHALL PROVIDE ANY REQUIRED LEVELING SCREWS OR SHIMS FOR ERECTION.

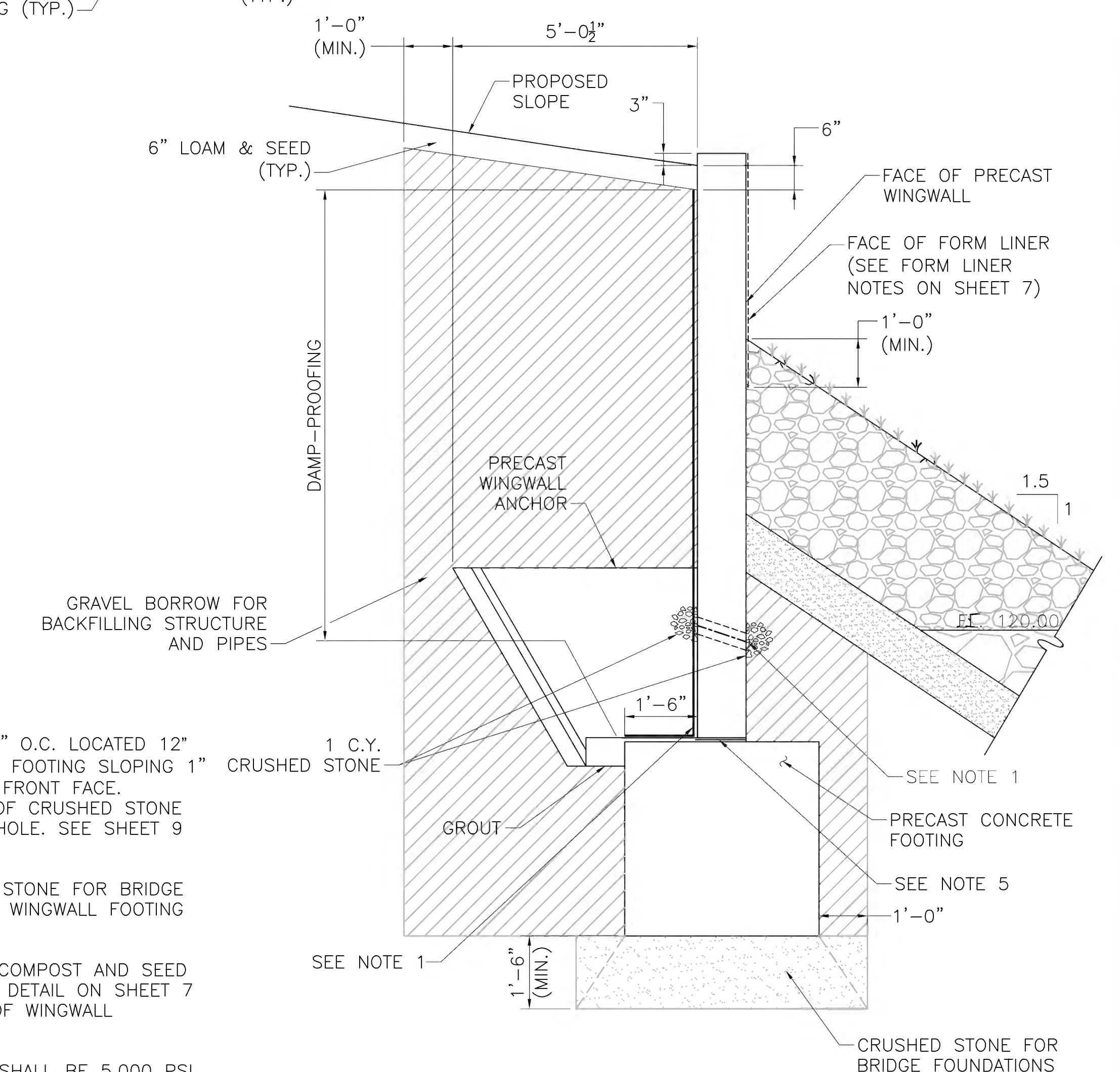

WINGWALL BACKFILL DETAIL
SCALE: 1/2"=1'-0"

MONTH DD, YYYY	ISSUED FOR CONSTRUCTION
DATE	DESCRIPTION
USE ONLY PRINTS OF LATEST DATE	

608164-BR(6-S-31-013)EARTHWORKS.DWG 18-February-2022 2:44 PM 2nd Structural Submittal (S2) 18-January-2022

STATE	FED. AID PROJ. NO.	SHEET NO.	TOTAL SHEETS
MA	XXX-XXXX(XXX)X	241	319
PROJECT FILE NO.		608164	

TYPICAL SECTIONS & ELEVATIONS

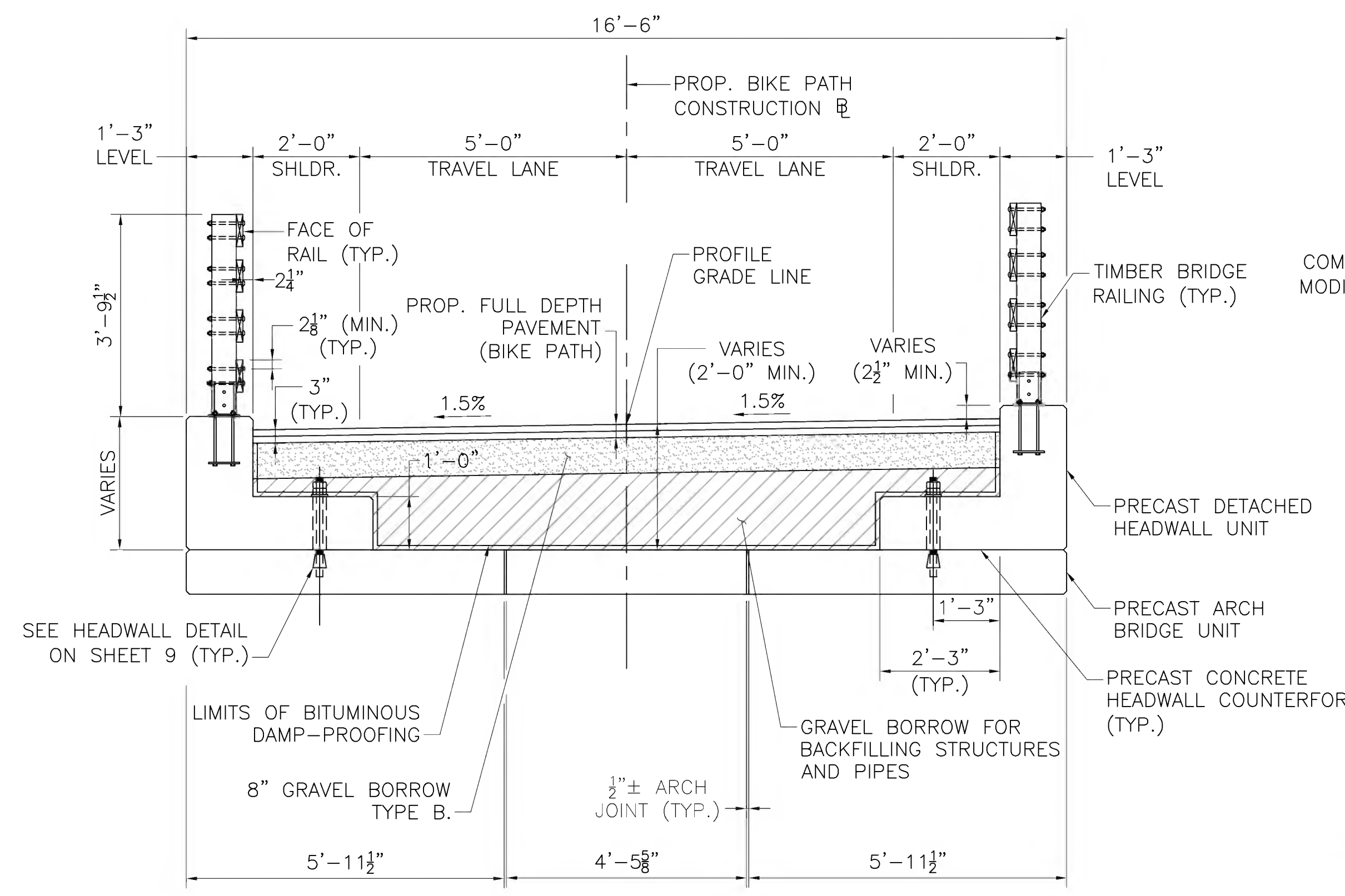

TRANSVERSE SECTION
SCALE: 1/2"=1'-0"

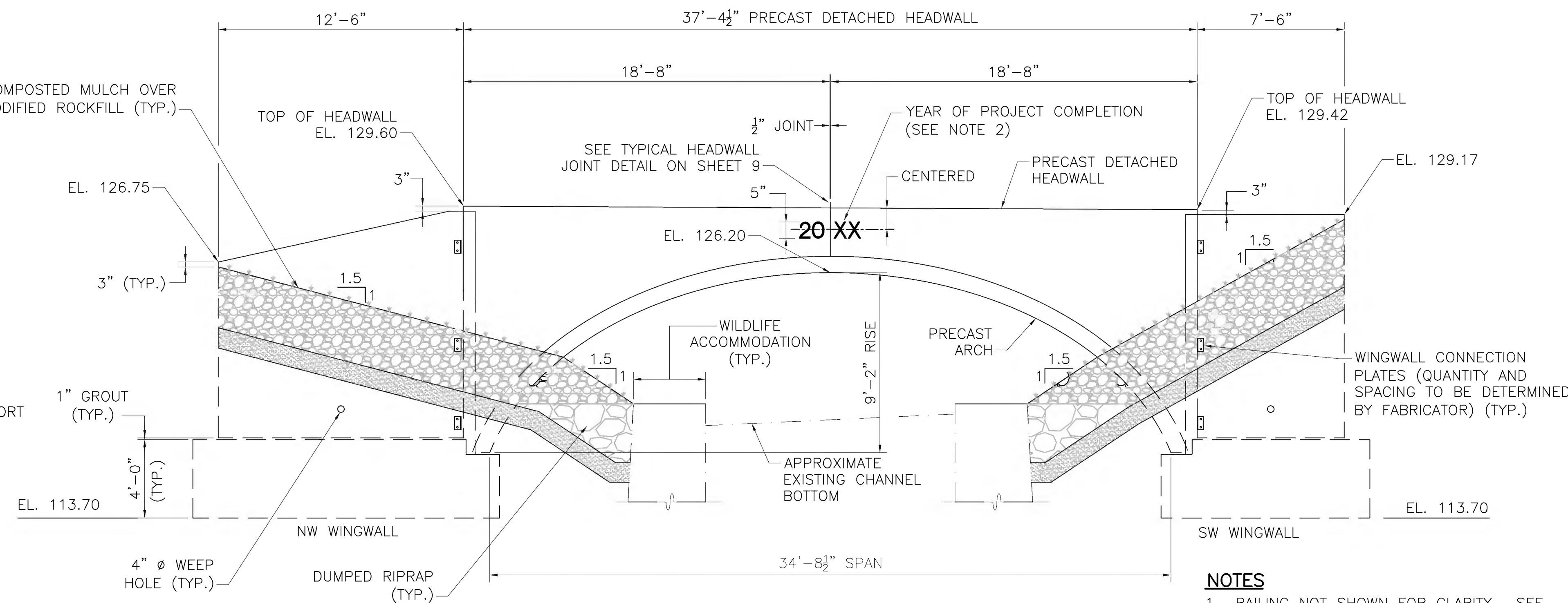

UPSTREAM ELEVATION
SCALE: 1/4"=1'-0"

- NOTES**
1. RAILING NOT SHOWN FOR CLARITY. SEE GENERAL PLAN ON SHEET 5 FOR POST LOCATIONS.
 2. USE LATEST CONTRACT COMPLETION YEAR IN EFFECT WHEN THE FIRST HEADWALL IS CAST. USE THIS YEAR FOR BOTH HEADWALLS.

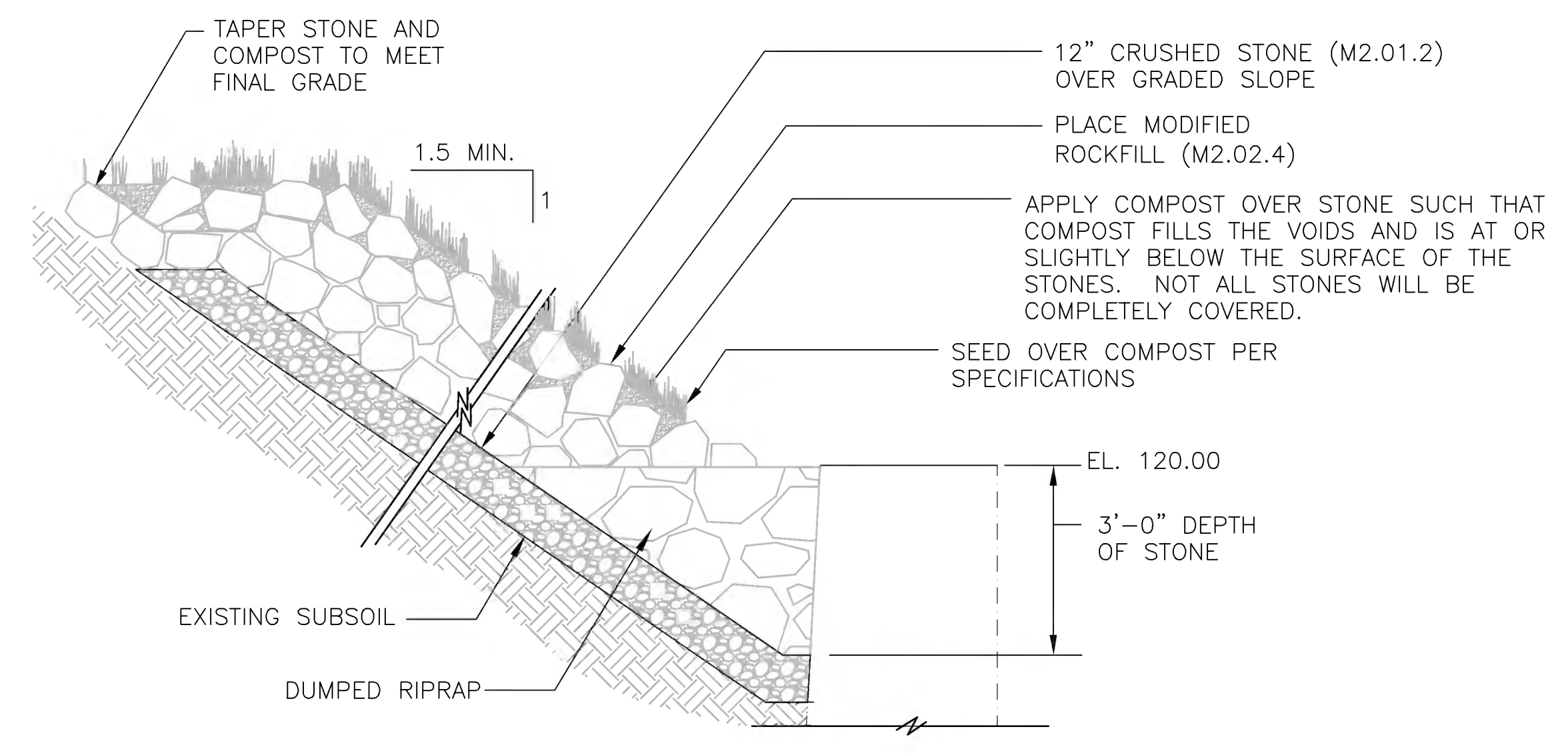

COMPOST AND SEED OVER MODIFIED ROCKFILL
SCALE: 3/8"=1'-0"

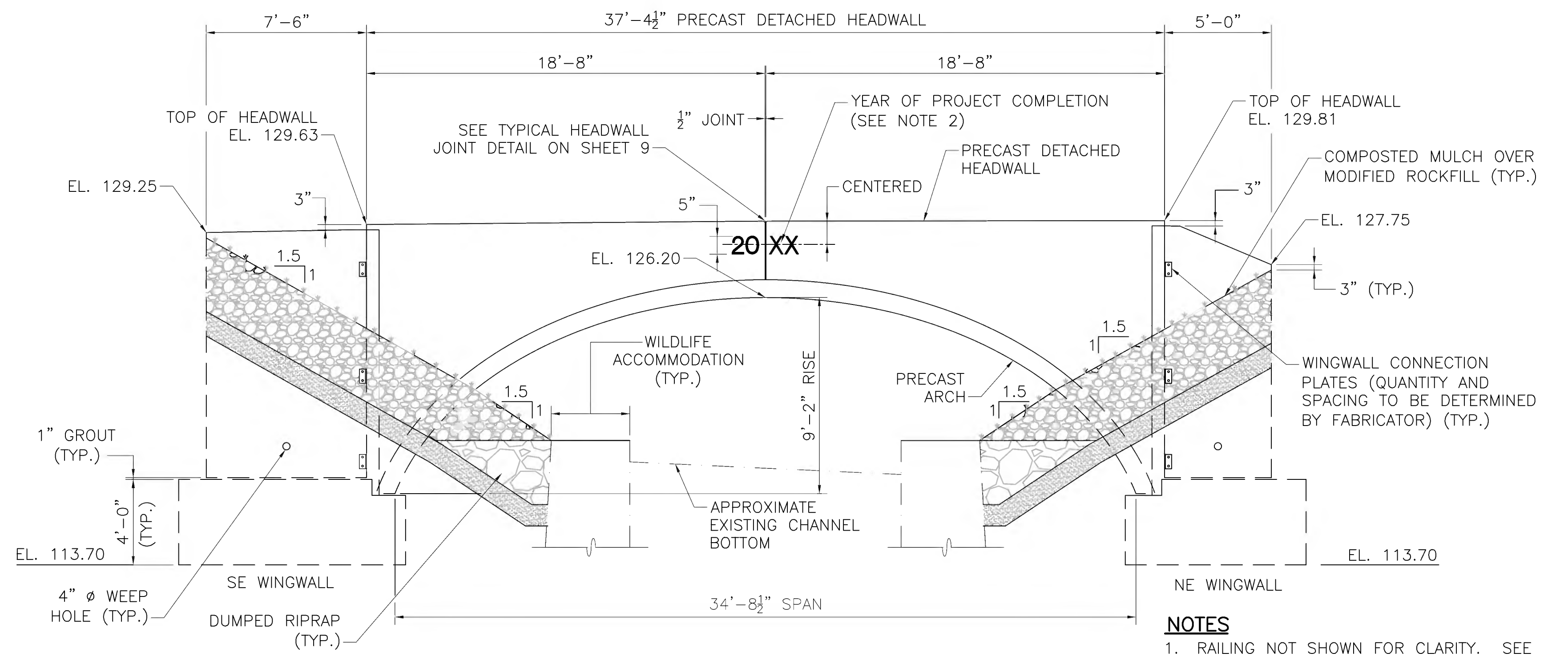

DOWNSTREAM ELEVATION
SCALE: 1/4"=1'-0"

- NOTES**
1. RAILING NOT SHOWN FOR CLARITY. SEE GENERAL PLAN ON SHEET 5 FOR POST LOCATIONS.
 2. USE LATEST CONTRACT COMPLETION YEAR IN EFFECT WHEN THE FIRST HEADWALL IS CAST. USE THIS YEAR FOR BOTH HEADWALLS.

WINGWALL AND HEADWALL FORM LINER NOTES:

1. EXPOSED FACES OF HEADWALLS AND WINGWALLS SHALL HAVE A PATTERNED FORM LINER AND SHALL EXTEND A MINIMUM OF 1' BELOW THE PROPOSED GRADE AT THE FACE OF THE WALL.
2. THE FORM LINER PATTERN SHALL BE CUSTOMROCK #1302 - RANDOM RUNNING BOND STONE OR APPROVED EQUAL AND SHALL BE STAINED TO SIMULATE THE APPEARANCE OF THE EXISTING MASONRY ABUTMENTS. THE COST OF THE FORM LINER SHALL BE INCLUDED UNDER ITEM 995.01, "BRIDGE STRUCTURE BRIDGE, NO. S-31-013." SEE SPECIAL PROVISIONS FOR ADDITIONAL INFORMATION.

MONTH DD, YYYY	ISSUED FOR CONSTRUCTION
USE ONLY PRINTS OF LATEST DATE	

608164_BRT(S-31-013)(DECKSECT).DWG 18-February-2022 2:44 PM 2nd Structural Submittal (S2) 18-January-2022

STATE	FED. AID PROJ. NO.	SHEET NO.	TOTAL SHEETS
MA	XXX-XXXX(XXX)X	242	319
PROJECT FILE NO.		608164	

FOUNDATION PLAN & DETAILS

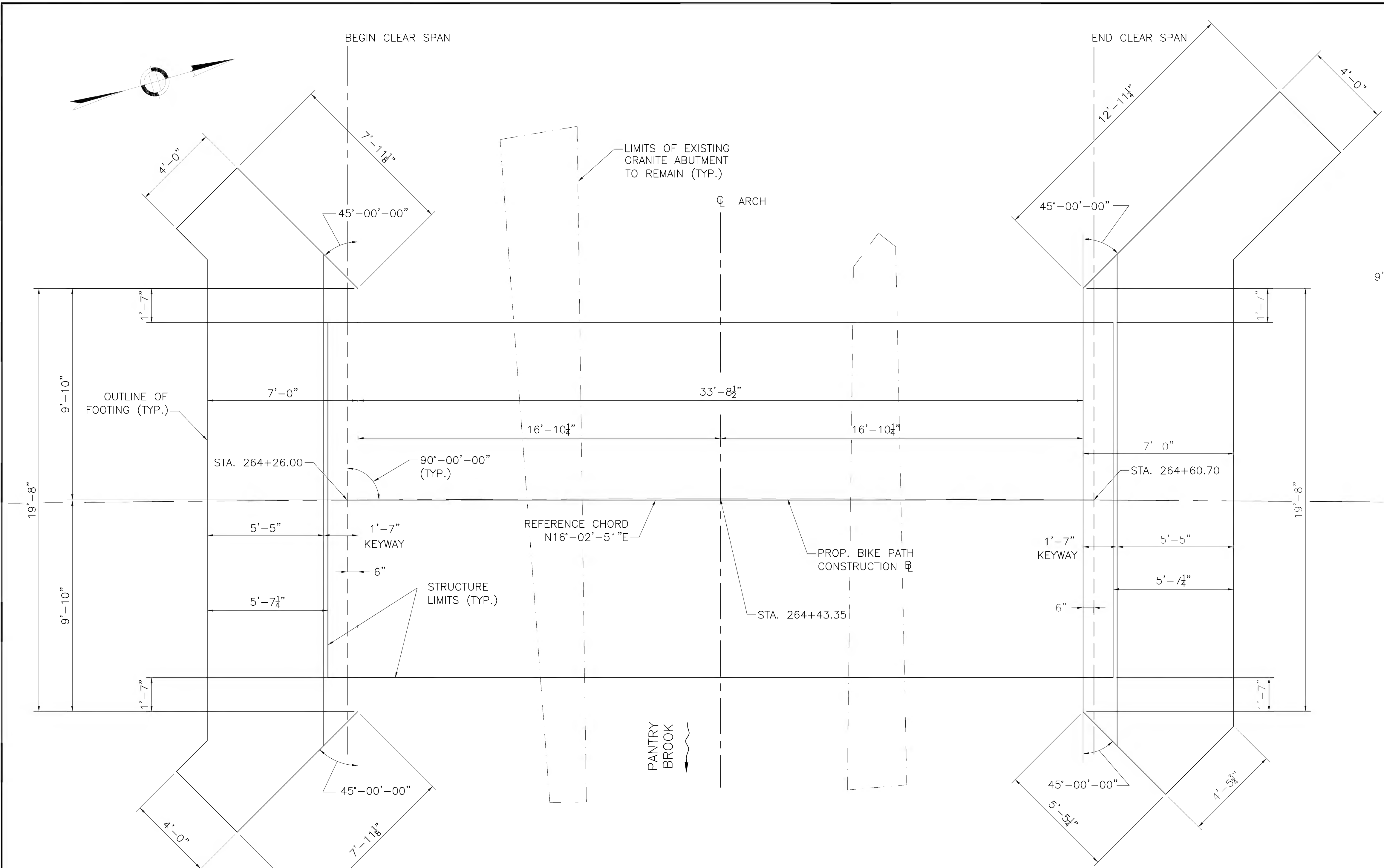

FOUNDATION PLAN
SCALE: 3/8"=1'-0"

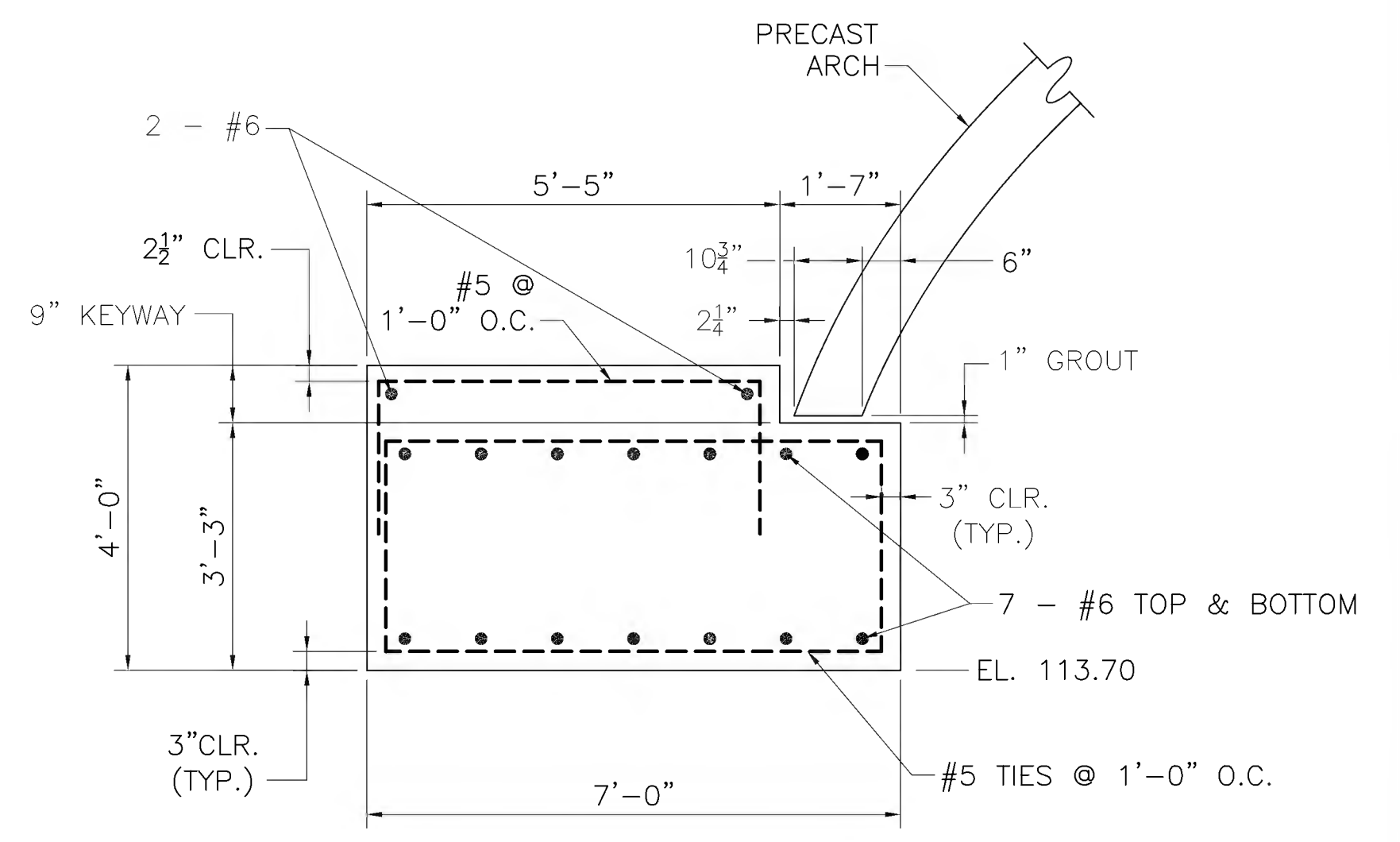

PRECAST FOOTING SECTION
SCALE: 1/2"=1'-0"

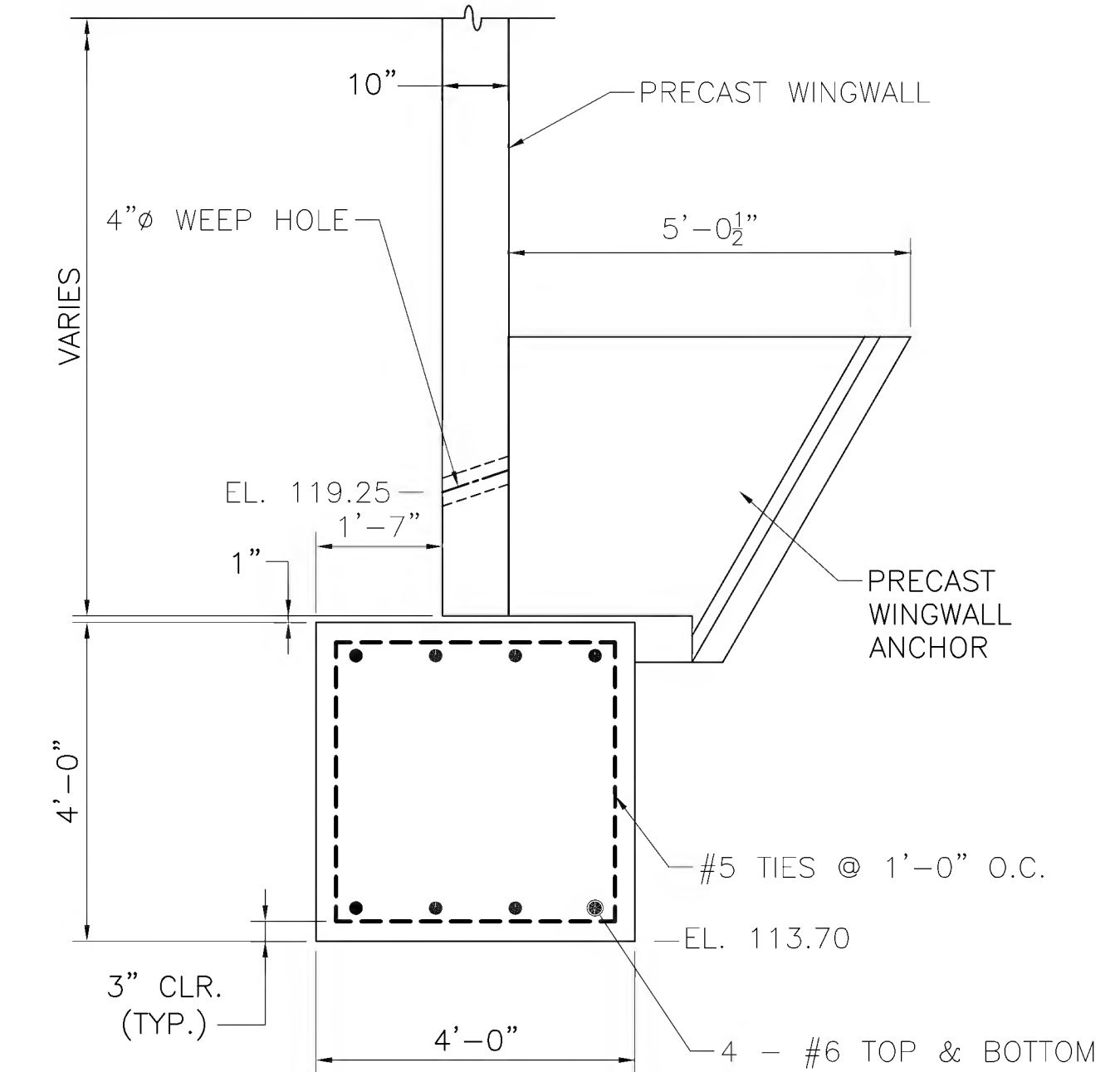

WINGWALL FOOTING SECTION
SCALE: 1/2"=1'-0"

NOTES:

1. THE PRECAST CONCRETE STRIP FOOTING IS PER CONTRACTOR DESIGN. THEREFORE, THE FACTORED BEARING PRESSURE WILL BE DETERMINED BY THE CONTRACTOR. SLIDING AND OVERTURNING OF THE PRECAST STRIP FOOTING SHALL ALSO BE CHECKED IN THE CONTRACTOR'S DESIGN USING THE INFORMATION PROVIDED IN THE GEOTECHNICAL REPORT.
2. FACTORED BEARING RESISTANCE:

FOOTING WIDTH (FT)	ECCENTRICITY (FT)	FACTORED BEARING RESISTANCE (KSF)
4	1.33	5.2
6	2.00	5.7
8	2.67	6.1

3. FACTORED BEARING RESISTANCE IS THE PRODUCT OF THE NOMINAL BEARING RESISTANCE AND A RESISTANCE FACTOR OF 0.45.

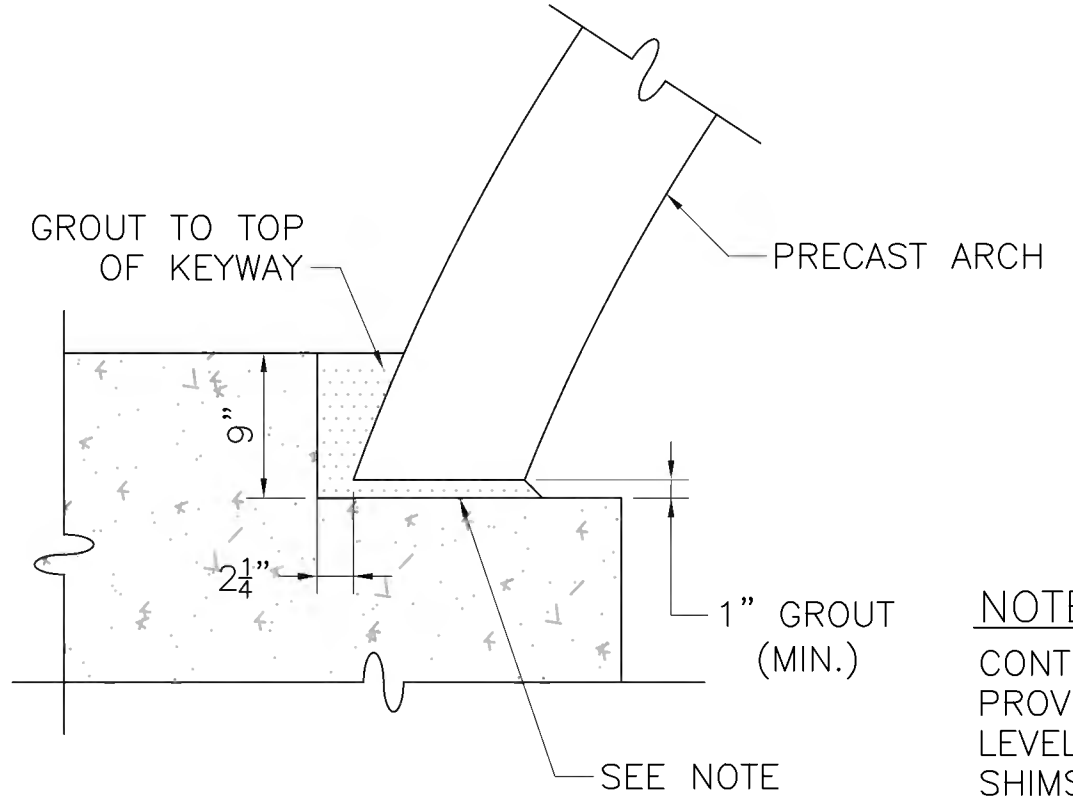

ARCH TYPICAL KEY DETAIL
SCALE: 1"=1'-0"

NOTE:

FILL ENTIRE KEYWAY INCLUDING NOMINAL 1" VOID BETWEEN BOTTOM OF KEYWAY AND BOTTOM OF PRECAST ARCH LEG WITH NON-SHRINK GROUT CONFORMING TO M4.04.0.

NOTE:

CONTRACTOR SHALL PROVIDE ANY REQUIRED LEVELING SCREWS OR SHIMS FOR ERECTION.

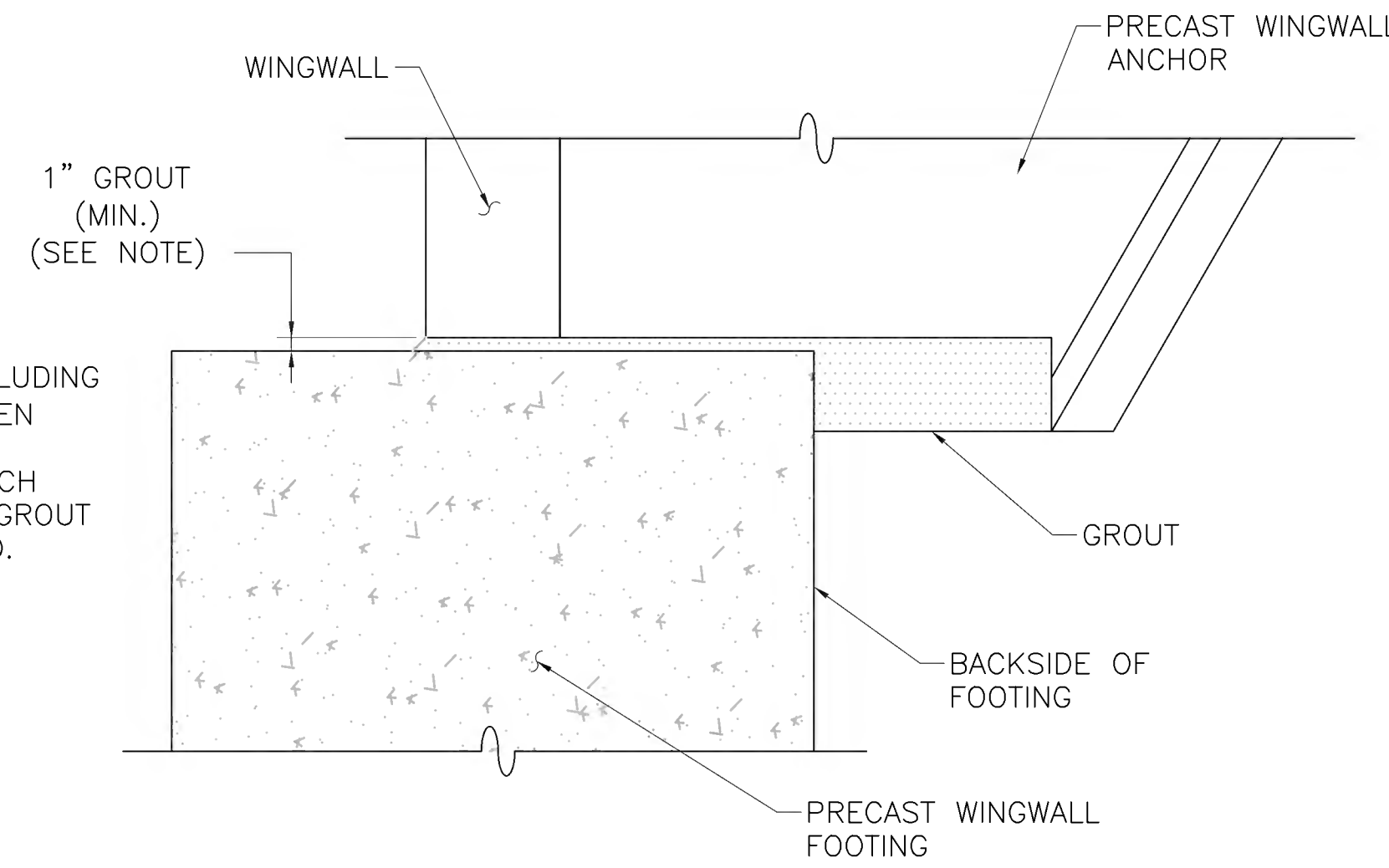

WINGWALL TYPICAL GROUT DETAIL
SCALE: 1"=1'-0"

NOTES:

1. MINIMUM 1" NON-SHRINK GROUT CONFORMING TO M4.04.0 UNDER WINGWALL LEG AND ANCHOR STEM.
2. AREA BETWEEN WINGWALL FOOTING AND ANCHOR SHALL BE GROUTED SOLID BEFORE BACKFILL.

MONTH DD, YYYY	ISSUED FOR CONSTRUCTION
DATE	DESCRIPTION
USE ONLY PRINTS OF LATEST DATE	

608164_BRS(S-31-013)FOUNDATION.DWG 18-January-2022 2:44 PM 2nd Structural Submittal (S2)

STATE	FED. AID PROJ. NO.	SHEET NO.	TOTAL SHEETS
MA	XXX-XXXX(XXX)X	243	319
PROJECT FILE NO.		608164	

PRECAST ARCH DETAILS & NOTES

PRECAST CONCRETE ELEMENT NOTES:

1. THE CONTRACTOR SHALL SUBMIT DESIGN CALCULATIONS FOR THE ARCH BRIDGE AND WINGWALL ELEMENTS, INCLUDING THE HEADWALL CONNECTION TO THE ARCH, THE ARCH AND WINGWALL FOOTINGS, AND THE WINGWALL ANCHORS IN ACCORDANCE WITH THE LATEST AASHTO LRFD DESIGN SPECIFICATIONS AND THE MASSACHUSETTS DEPARTMENT OF TRANSPORTATION'S LRFD BRIDGE DESIGN MANUAL FOR H10 TRUCK LOADING AND PEDESTRIAN LOADING FOR APPROVAL OF THE ENGINEER. THE DESIGN COMPUTATIONS SHALL CONSIDER ALL LOADINGS AS APPROPRIATE DURING FABRICATION, SHIPMENT, ERECTION, CONSTRUCTION, AND AFTER COMPLETION OF CONSTRUCTION BASED ON THESE CONSTRUCTION DRAWINGS. THE RAIL POST ANCHORAGE SPACING SHALL BE DETAILED ON SHOP DRAWINGS FOR REVIEW AND APPROVAL BY THE ENGINEER.
2. THE ARCH DIMENSIONS PROVIDED ARE SHOWN TO ESTABLISH THE SIZE OF THE PROPOSED OPENING OF 141 SQUARE FEET. THE WIDTHS AND THICKNESSES OF EACH ARCH UNIT MAY VARY DEPENDING UPON THE MANUFACTURER'S SPECIFICATIONS. AN ARCH TYPE STRUCTURE SHALL BE REQUIRED. THE CONTRACTOR, AT NO ADDITIONAL COMPENSATION, HAS THE OPTION TO PROPOSE AN ALTERNATE ARCH DESIGN WITH THE SAME OR LARGER OPENING AREA.
3. THE PRECAST FOOTING DESIGN DETAILED HEREIN WAS BASED ON THE GEOMETRY OF THE ARCH SHOWN. SEE FACTORED BEARING RESISTANCES BY SIZE ON SHEET 8. THE FABRICATOR SHALL PREPARE AND THE CONTRACTOR SHALL SUBMIT THE FINAL DESIGN OF THE FOOTING FOR APPROVAL BY THE ENGINEER.
4. THE CONTRACTOR, AT NO ADDITIONAL COMPENSATION, HAS THE OPTION TO PROVIDE CAST-IN-PLACE CONCRETE FOOTINGS, AND SHALL SUBMIT THE FINAL DESIGN OF THE CAST-IN-PLACE CONCRETE FOOTINGS.
5. THE PRECAST ELEMENTS ARE TO BE PARALLEL AND ALIGNED WITH THE REFERENCE LINE AS SHOWN ON THESE CONSTRUCTION DRAWINGS.
6. A MINIMUM OF 4 FEET COVER TO THE BOTTOM OF FOOTING SHALL BE PROVIDED.
7. THE FABRICATOR IS RESPONSIBLE FOR THE DESIGN AND INSTALLATION OF LIFT HOOKS FOR ALL PRECAST ELEMENTS. PLANS PROVIDING SPACING AND LOCATION OF LIFTING DEVICES AND HANDLING STRESS CALCULATIONS SHALL BE PROVIDED TO THE ENGINEER FOR REVIEW AND APPROVAL PRIOR TO FABRICATION OF THE PRECAST ELEMENTS.
8. SHOP DRAWINGS AND DESIGN CALCULATIONS SHALL BE SIGNED AND SEALED BY A PROFESSIONAL ENGINEER REGISTERED IN THE COMMONWEALTH OF MASSACHUSETTS.
9. PRECAST CONCRETE ELEMENTS SHALL CONFORM TO THE APPLICABLE PARTS OF SECTION 901 OF THE SPECIFICATIONS.
10. ALL TOLERANCES FOR JOINTS BETWEEN PRECAST ELEMENTS SHALL BE DETERMINED BY THE CONTRACTOR AND SHALL BE IN ACCORDANCE WITH PCI REQUIREMENTS.

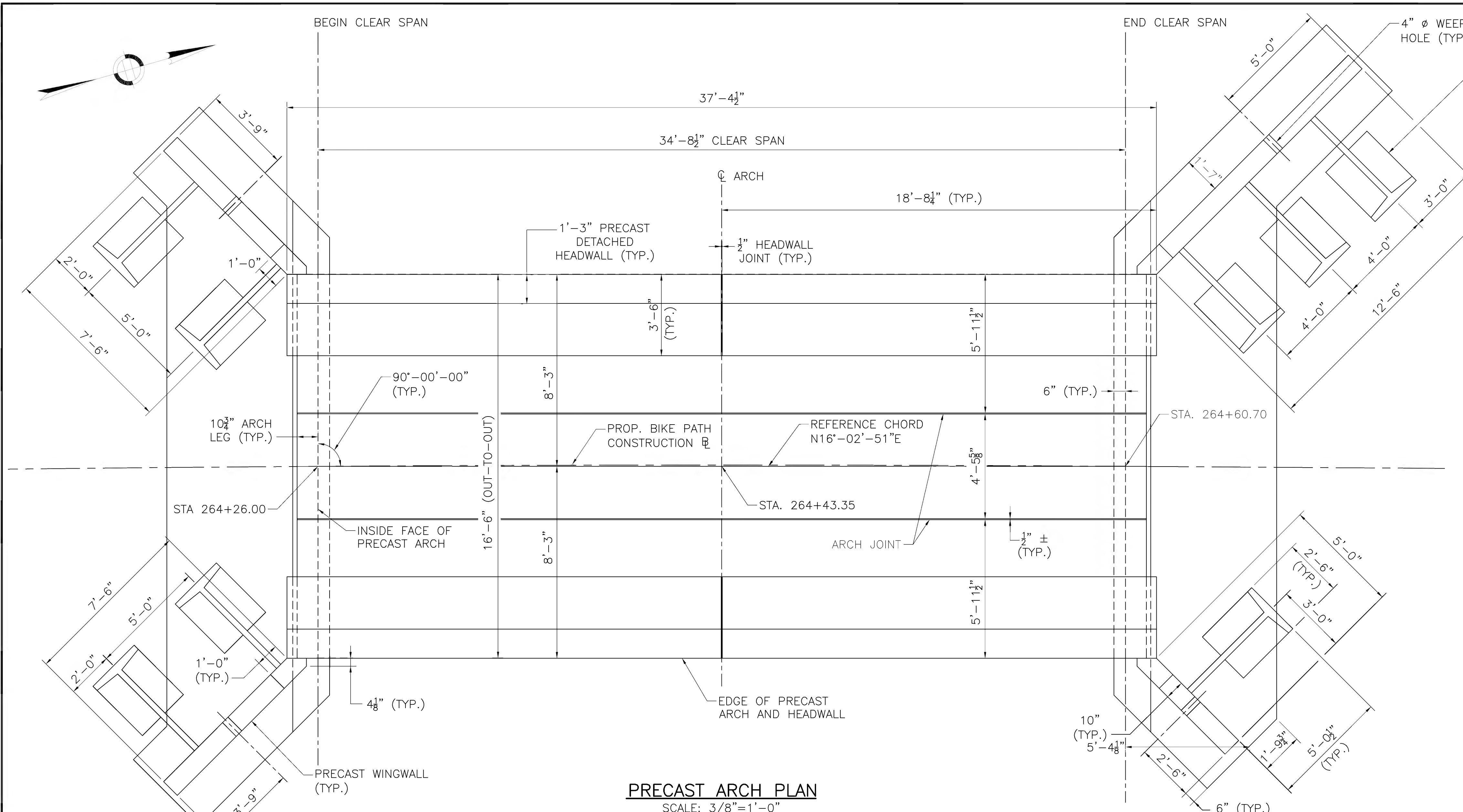

PRECAST ARCH PLAN
SCALE: 3/8"=1'-0"

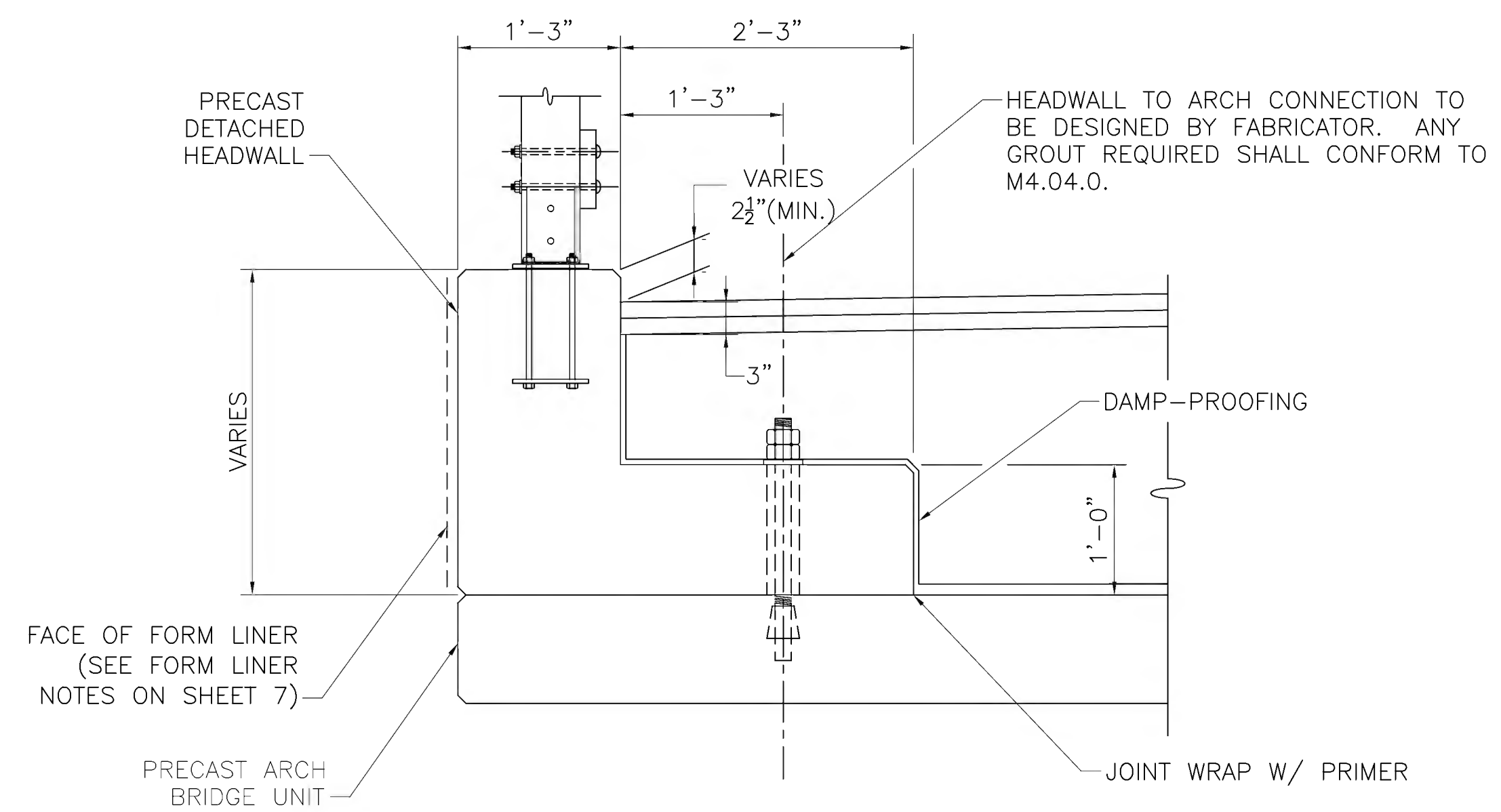

HEADWALL DETAIL
SCALE: 1"=1'-0"

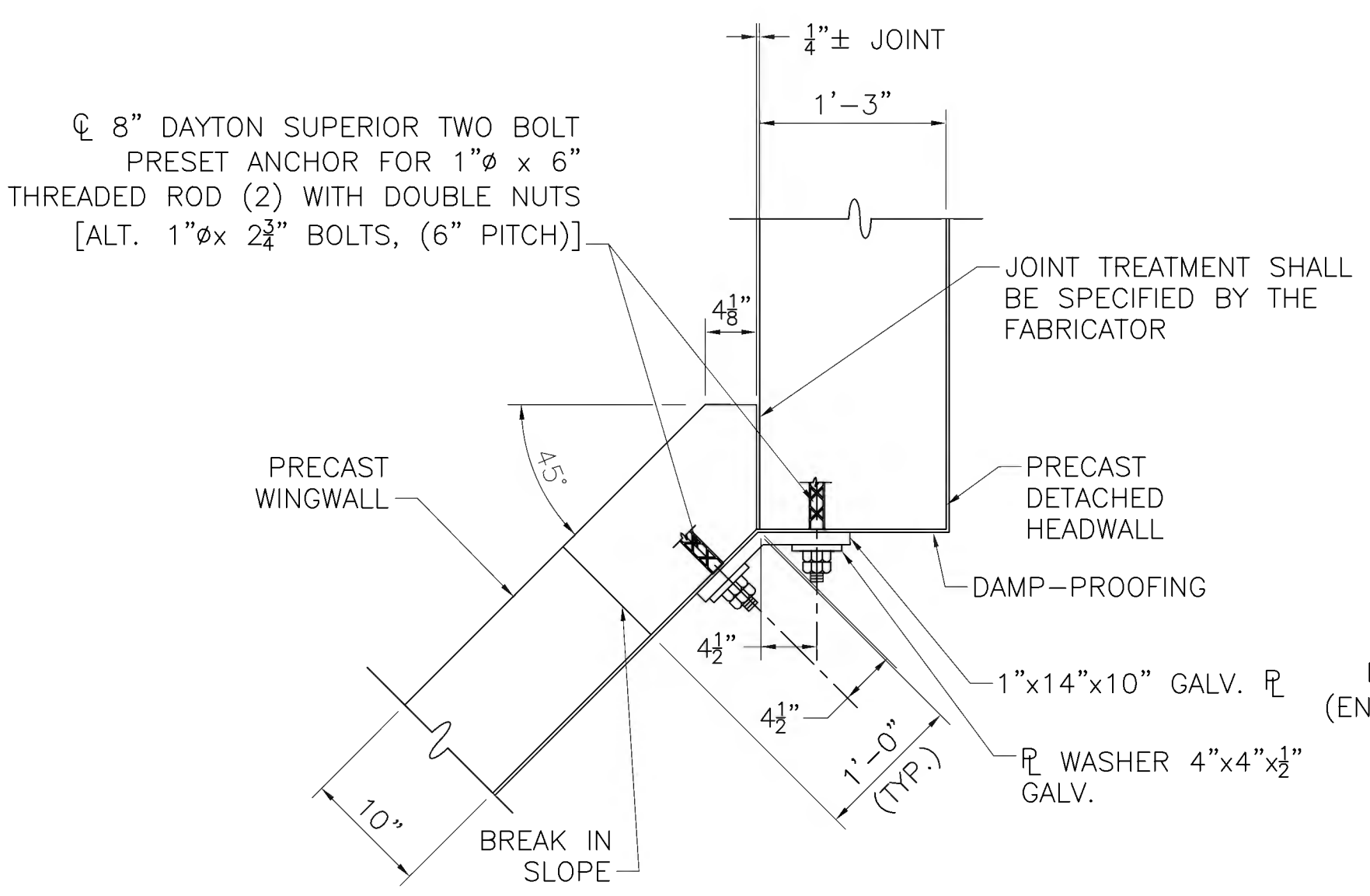

WINGWALL TO HEADWALL JOINT DETAIL
SCALE: 1"=1'-0"

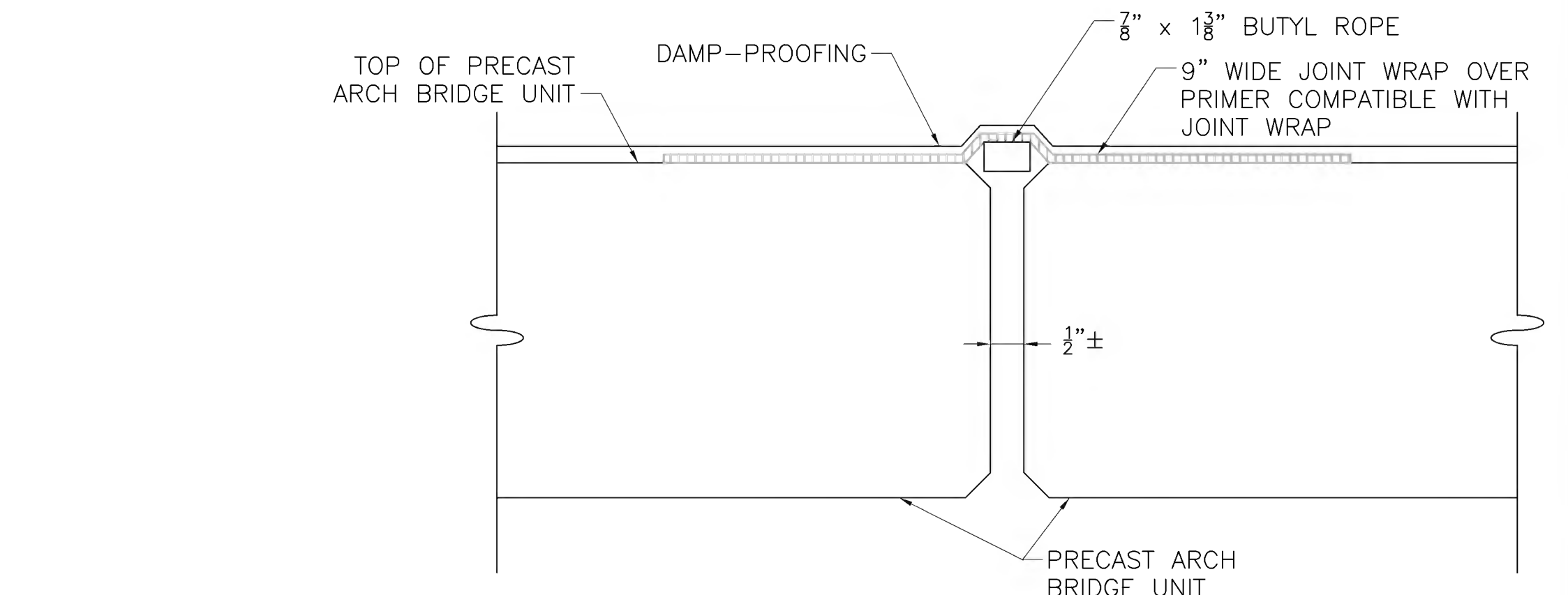

TYPICAL JOINT SEAL DETAIL
SCALE: 3"=1'-0"

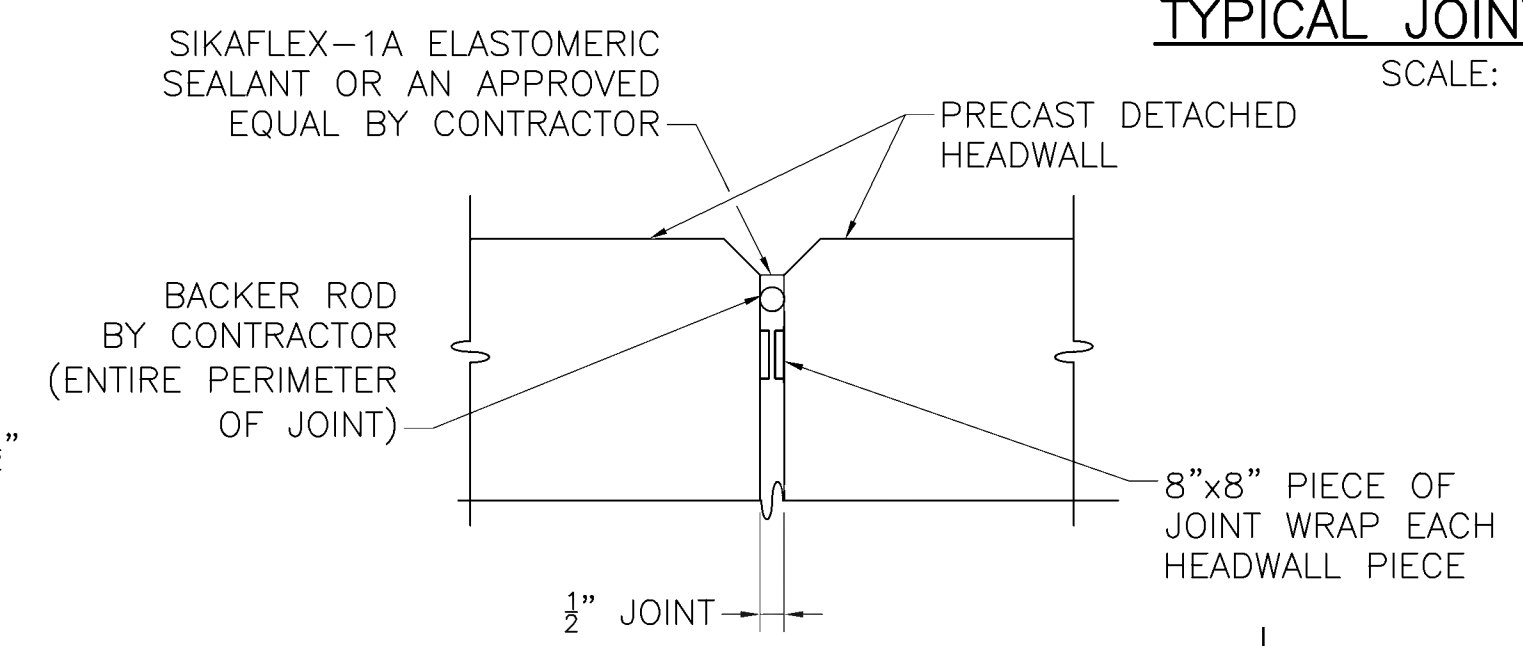

TYPICAL HEADWALL JOINT DETAIL
SCALE: 1"=1'-0"

MONTH DD, YYYY	ISSUED FOR CONSTRUCTION
DATE	DESCRIPTION
USE ONLY PRINTS OF LATEST DATE	

608164_BRF(S-31-013)PRECAST.DWG Plotted on 18-Feb-2022 2:45 PM 2nd Structural Submittal (S2) 18-January-2022

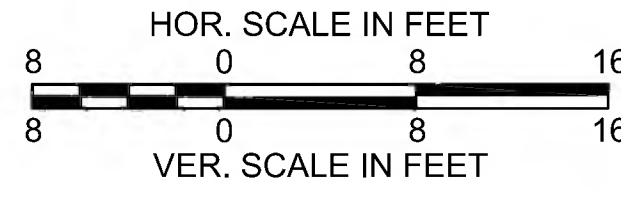

SUDBURY
 BRUCE FREEMAN RAIL TRAIL

STATE	FED. AID PROJ. NO.	SHEET NO.	TOTAL SHEETS
MA	XXX-XXX(XXX)X	245	319

PROJECT FILE NO. 608164

CROSS SECTIONS

Total Volume at Station 102+00.00

Cut Area (SF)	9.488
Fill Area (SF)	0.350
Cut Vol (CF)	37.071
Fill Vol (CF)	0.4
Cum Cut Vol (CF)	100.898
Cum Fill Vol (CF)	0.6
Net Vol (CF)	100.297

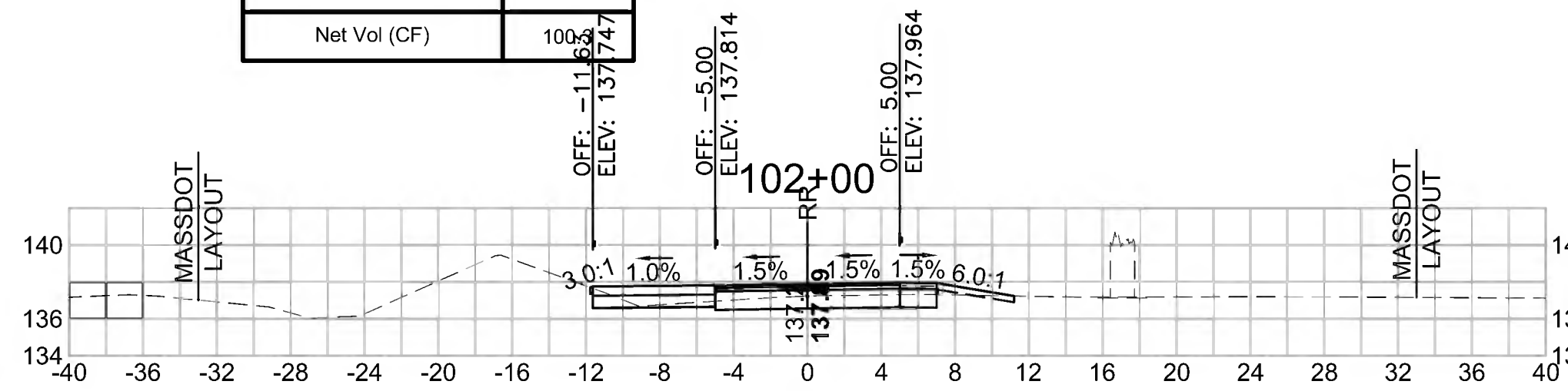

Total Volume at Station 103+50.00

Cut Area (SF)	11.445
Fill Area (SF)	0.994
Cut Vol (CF)	13.330
Fill Vol (CF)	5.7
Cum Cut Vol (CF)	137.088
Cum Fill Vol (CF)	17.9
Net Vol (CF)	119.2

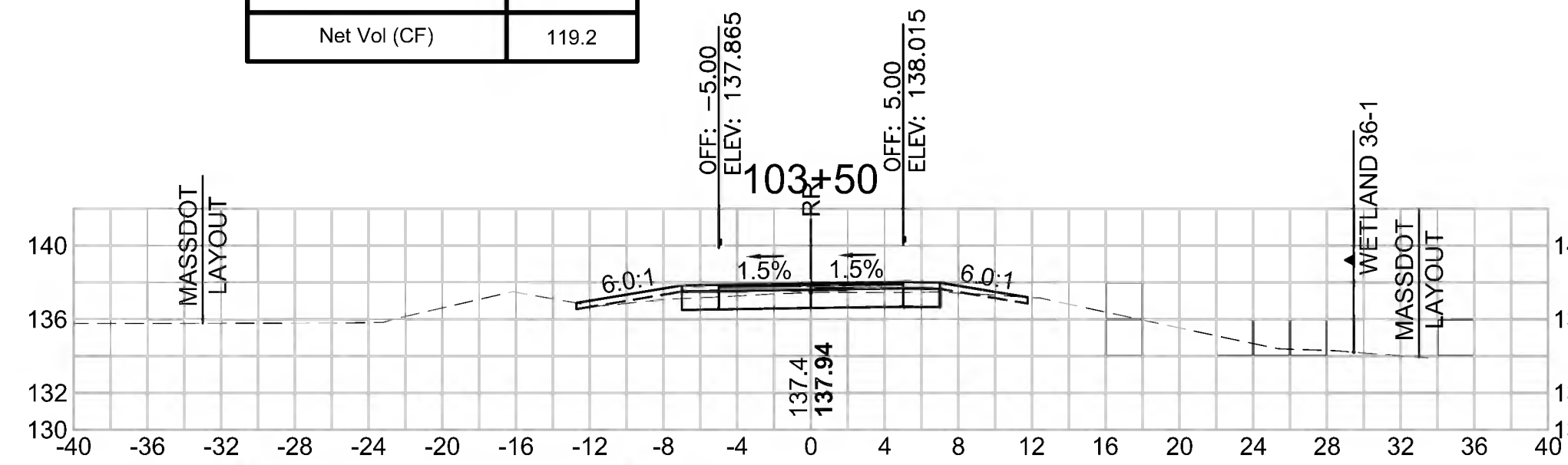

Total Volume at Station 105+00.00

Cut Area (SF)	37.599
Fill Area (SF)	0.000
Cut Vol (CF)	64.912
Fill Vol (CF)	0.0
Cum Cut Vol (CF)	270.355
Cum Fill Vol (CF)	20.5
Net Vol (CF)	249.9

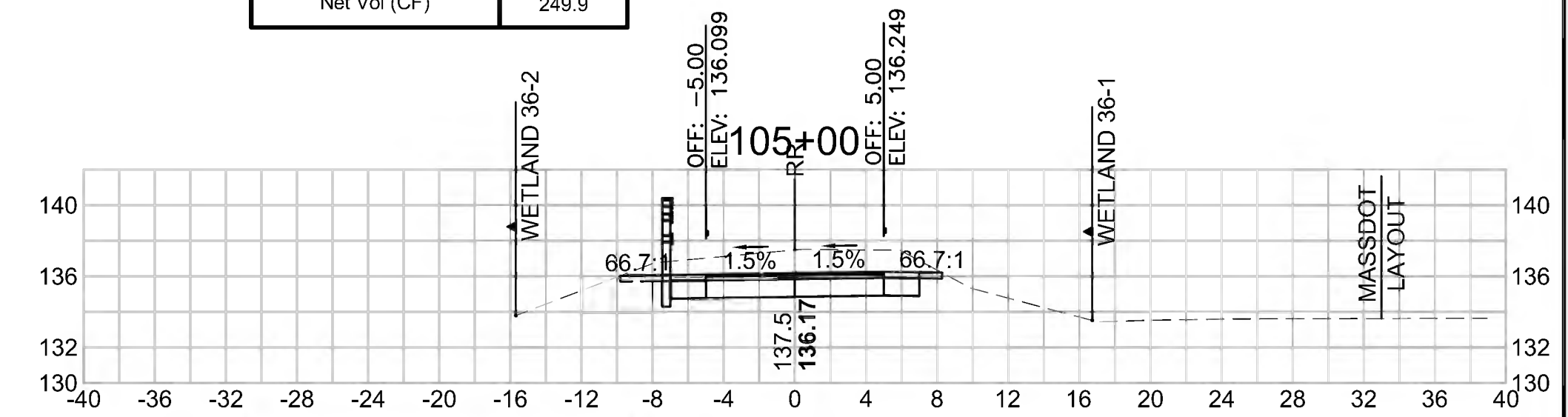

Total Volume at Station 101+50.00

Cut Area (SF)	30.547
Fill Area (SF)	0.131
Cut Vol (CF)	46.057
Fill Vol (CF)	0.1
Cum Cut Vol (CF)	63.828
Cum Fill Vol (CF)	0.1
Net Vol (CF)	63.7

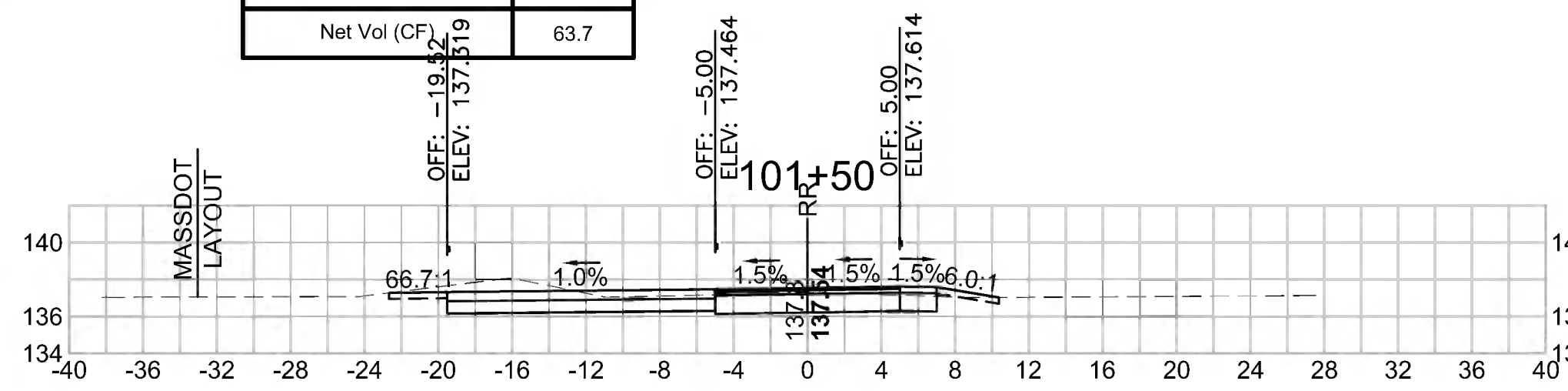

Total Volume at Station 103+00.00

Cut Area (SF)	2.951
Fill Area (SF)	5.186
Cut Vol (CF)	8.405
Fill Vol (CF)	8.1
Cum Cut Vol (CF)	123.759
Cum Fill Vol (CF)	12.2
Net Vol (CF)	111.5

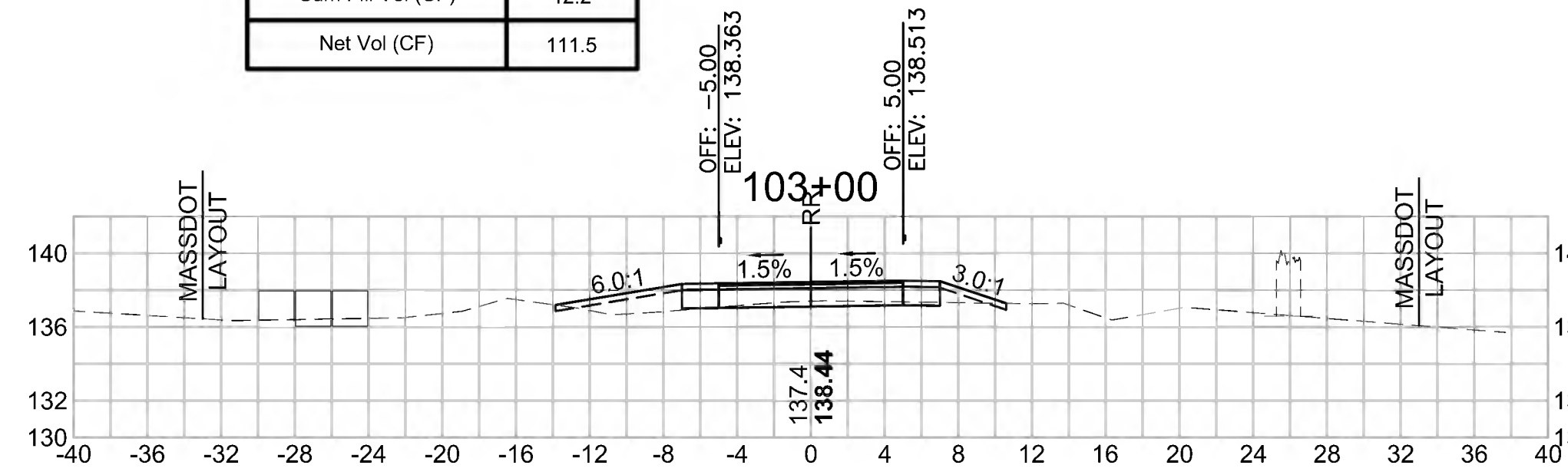

Total Volume at Station 104+50.00

Cut Area (SF)	32.506
Fill Area (SF)	0.000
Cut Vol (CF)	43.929
Fill Vol (CF)	0.8
Cum Cut Vol (CF)	205.443
Cum Fill Vol (CF)	20.5
Net Vol (CF)	185.0

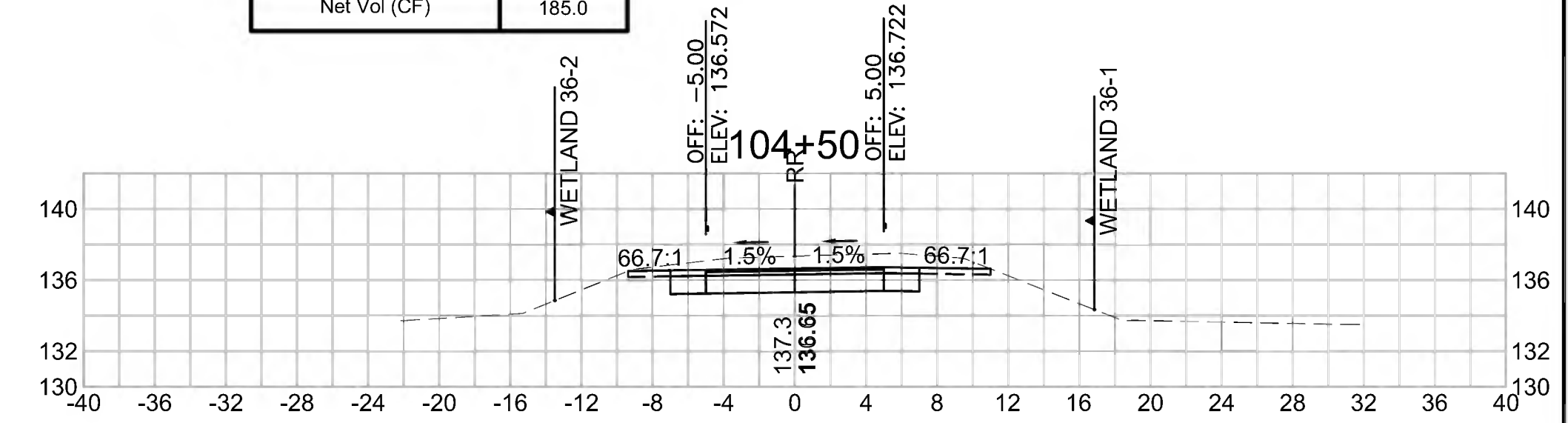

Total Volume at Station 101+00.00

Cut Area (SF)	19.193
Fill Area (SF)	0.000
Cut Vol (CF)	17.772
Fill Vol (CF)	0.0
Cum Cut Vol (CF)	17.771
Cum Fill Vol (CF)	0.0
Net Vol (CF)	17.8

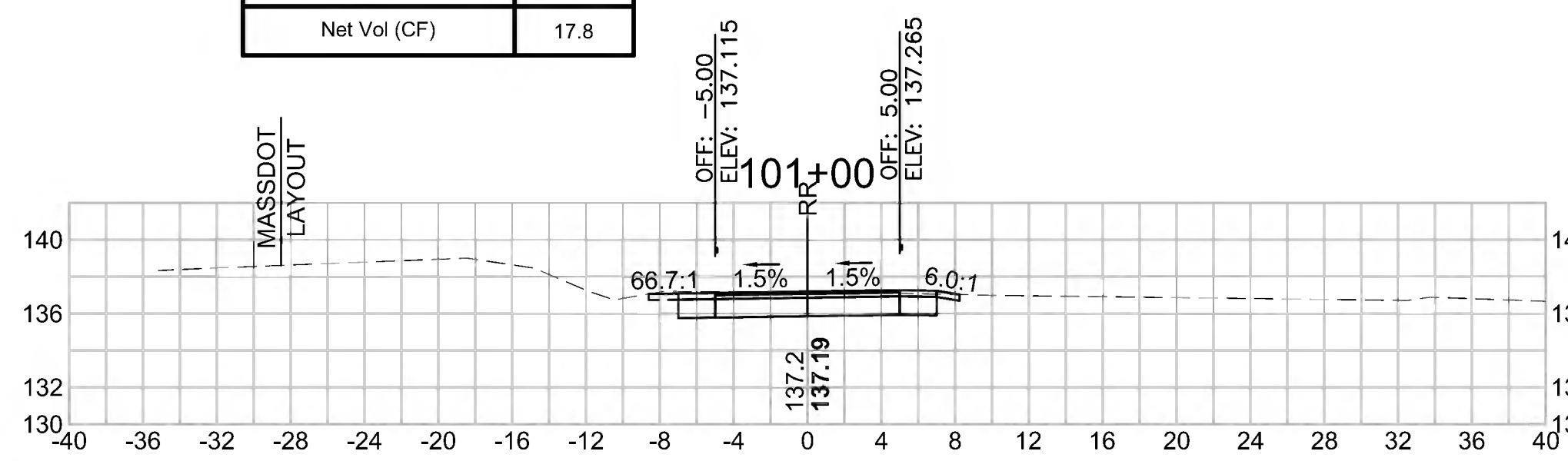

Total Volume at Station 102+50.00

Cut Area (SF)	6.126
Fill Area (SF)	3.521
Cut Vol (CF)	14.458
Fill Vol (CF)	3.6
Cum Cut Vol (CF)	115.355
Cum Fill Vol (CF)	4.2
Net Vol (CF)	111.2

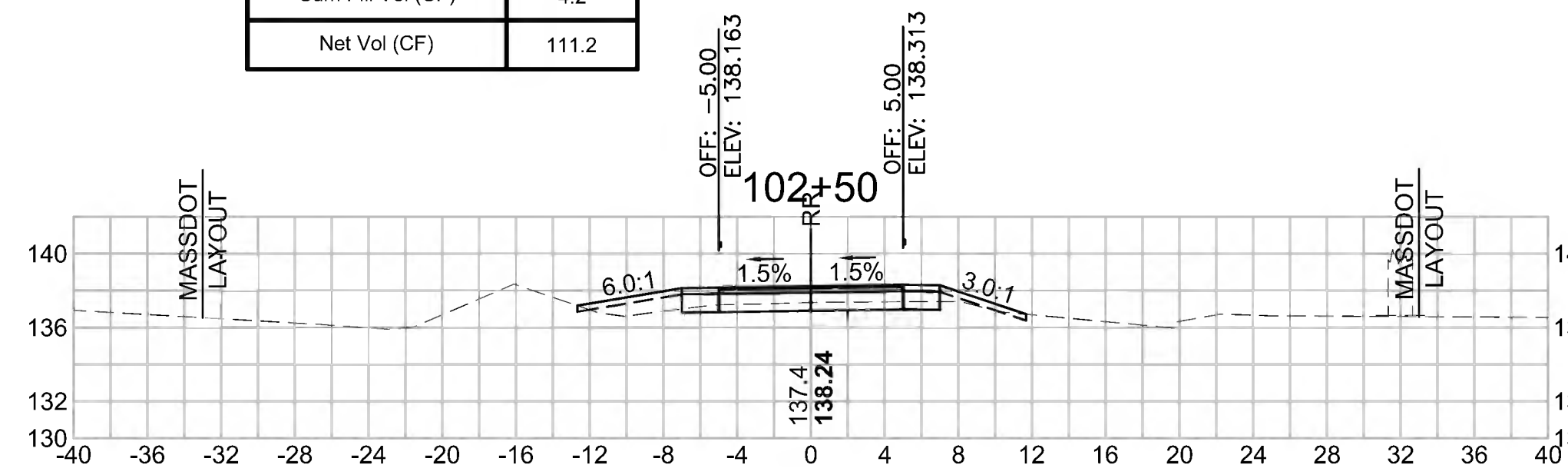

Total Volume at Station 104+00.00

Cut Area (SF)	14.937
Fill Area (SF)	0.878
Cut Vol (CF)	24.428
Fill Vol (CF)	1.7
Cum Cut Vol (CF)	161.515
Cum Fill Vol (CF)	19.7
Net Vol (CF)	141.8

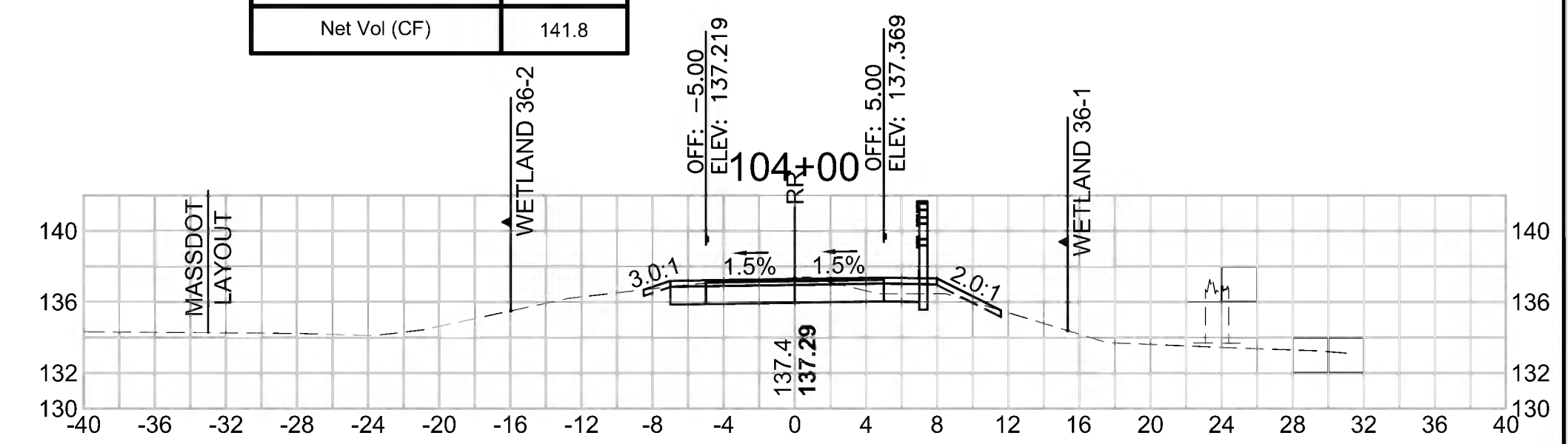

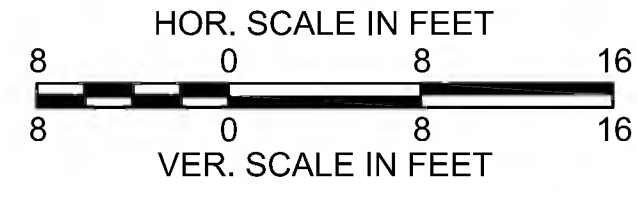

SUDBURY
 BRUCE FREEMAN RAIL TRAIL

STATE	FED. AID PROJ. NO.	SHEET NO.	TOTAL SHEETS
MA	XXX-XXXX(XXX)X	246	319

PROJECT FILE NO. 608164

CROSS SECTIONS

Total Volume at Station 106+50.00

Cut Area (SF)	22.438
Fill Area (SF)	2.741
Cut Vol (CF)	49.607
Fill Vol (CF)	2.5
Cum Cut Vol (CF)	454.076
Cum Fill Vol (CF)	23.0
Net Vol (CF)	431.1

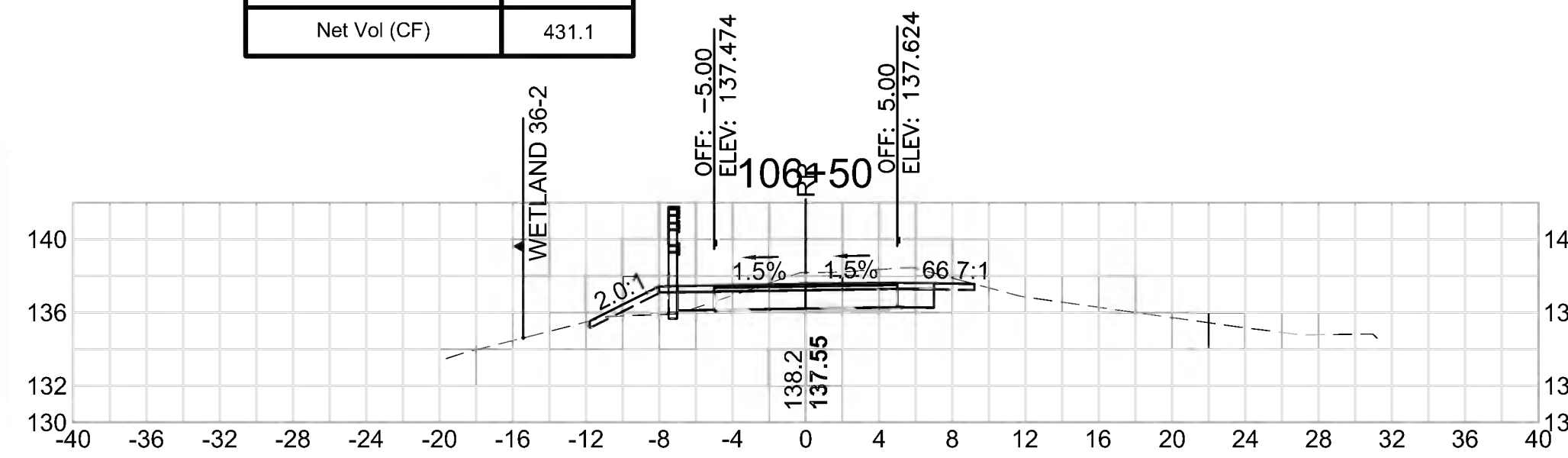

Total Volume at Station 108+00.00

Cut Area (SF)	17.189
Fill Area (SF)	0.008
Cut Vol (CF)	34.694
Fill Vol (CF)	0.0
Cum Cut Vol (CF)	566.731
Cum Fill Vol (CF)	28.0
Net Vol (CF)	538.7

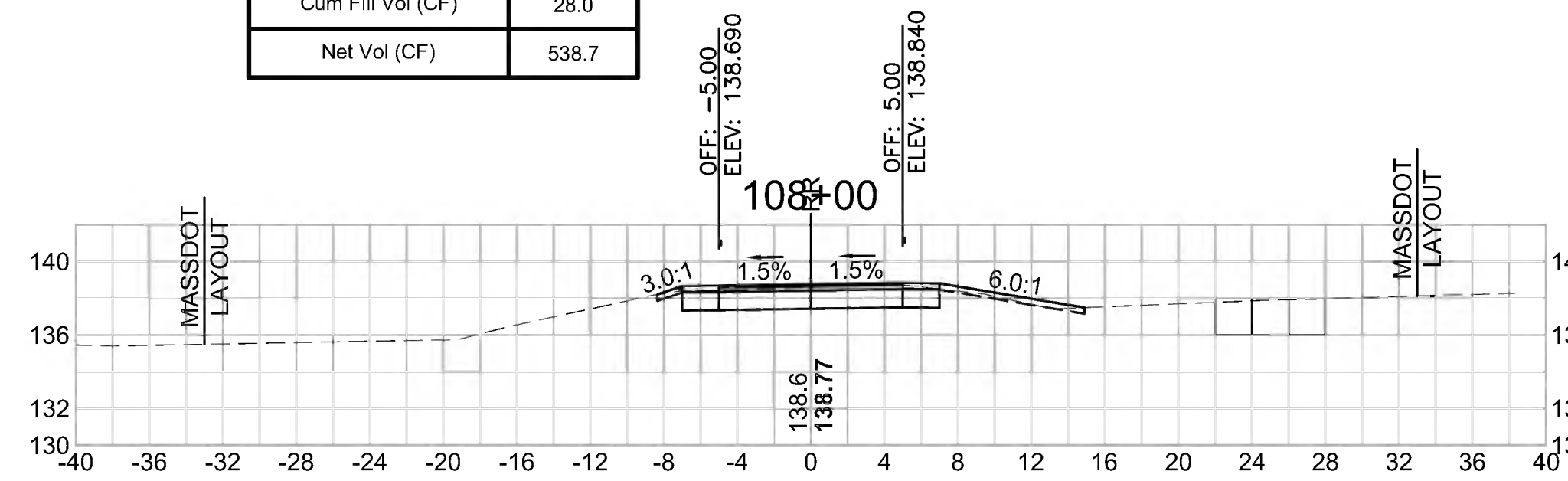

Total Volume at Station 109+50.00

Cut Area (SF)	31.928
Fill Area (SF)	0.000
Cut Vol (CF)	46.306
Fill Vol (CF)	1.0
Cum Cut Vol (CF)	696.427
Cum Fill Vol (CF)	30.0
Net Vol (CF)	666.4

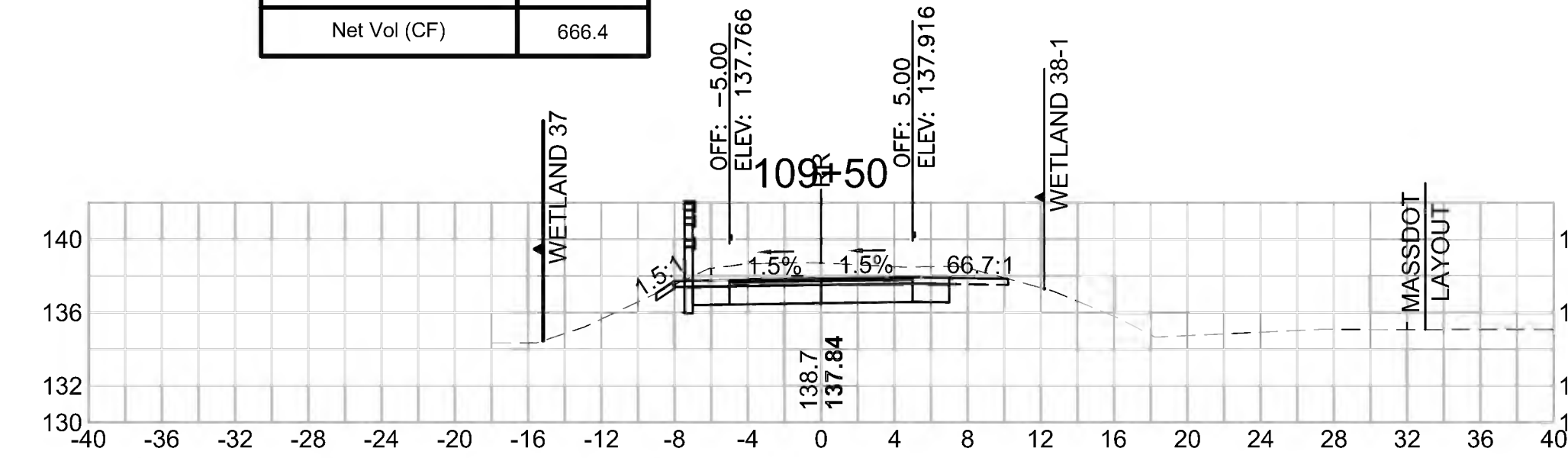

Total Volume at Station 106+00.00

Cut Area (SF)	31.138
Fill Area (SF)	0.000
Cut Vol (CF)	64.066
Fill Vol (CF)	0.0
Cum Cut Vol (CF)	404.469
Cum Fill Vol (CF)	20.5
Net Vol (CF)	384.0

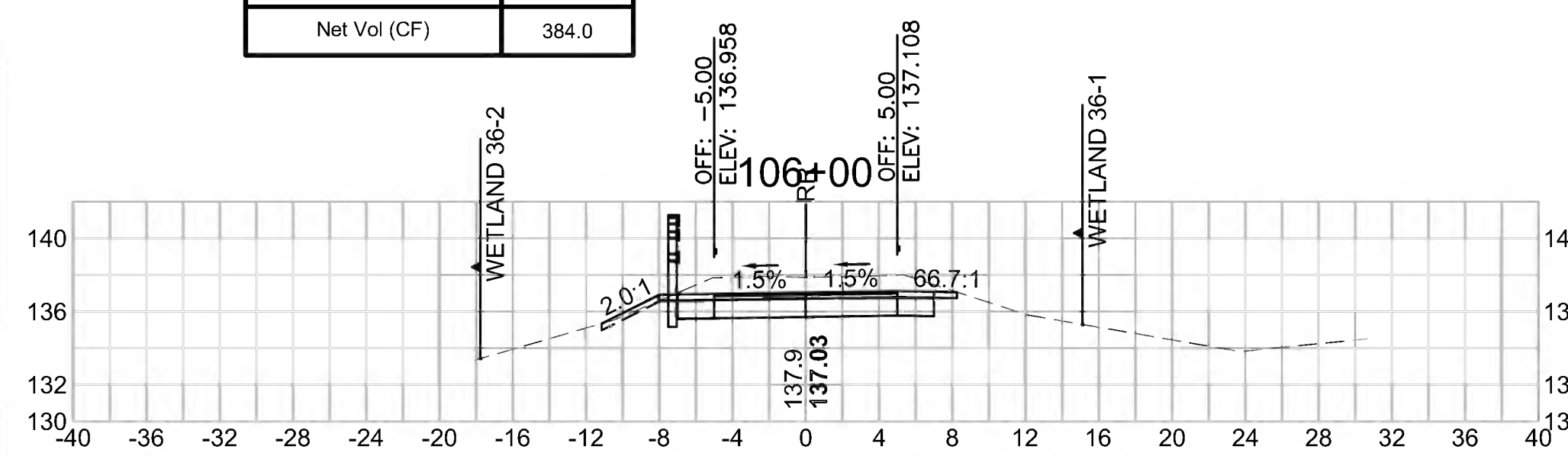

Total Volume at Station 107+50.00

Cut Area (SF)	20.280
Fill Area (SF)	0.000
Cut Vol (CF)	37.982
Fill Vol (CF)	1.2
Cum Cut Vol (CF)	532.037
Cum Fill Vol (CF)	28.0
Net Vol (CF)	504.0

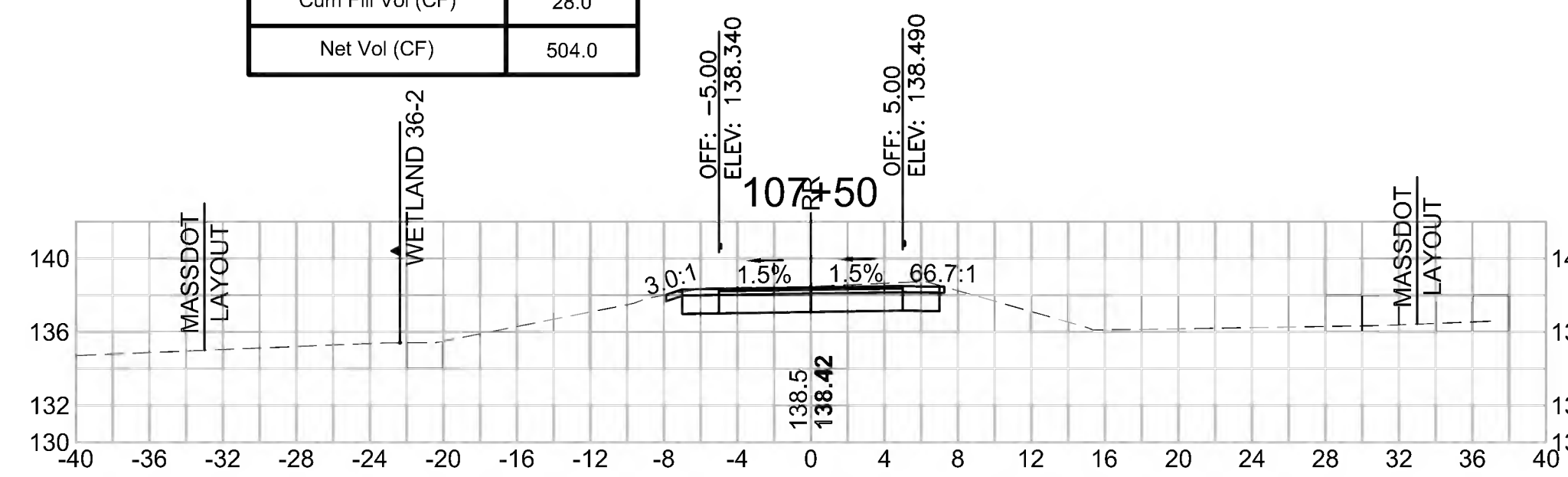

Total Volume at Station 109+00.00

Cut Area (SF)	18.081
Fill Area (SF)	1.072
Cut Vol (CF)	42.109
Fill Vol (CF)	1.0
Cum Cut Vol (CF)	650.122
Cum Fill Vol (CF)	29.0
Net Vol (CF)	621.1

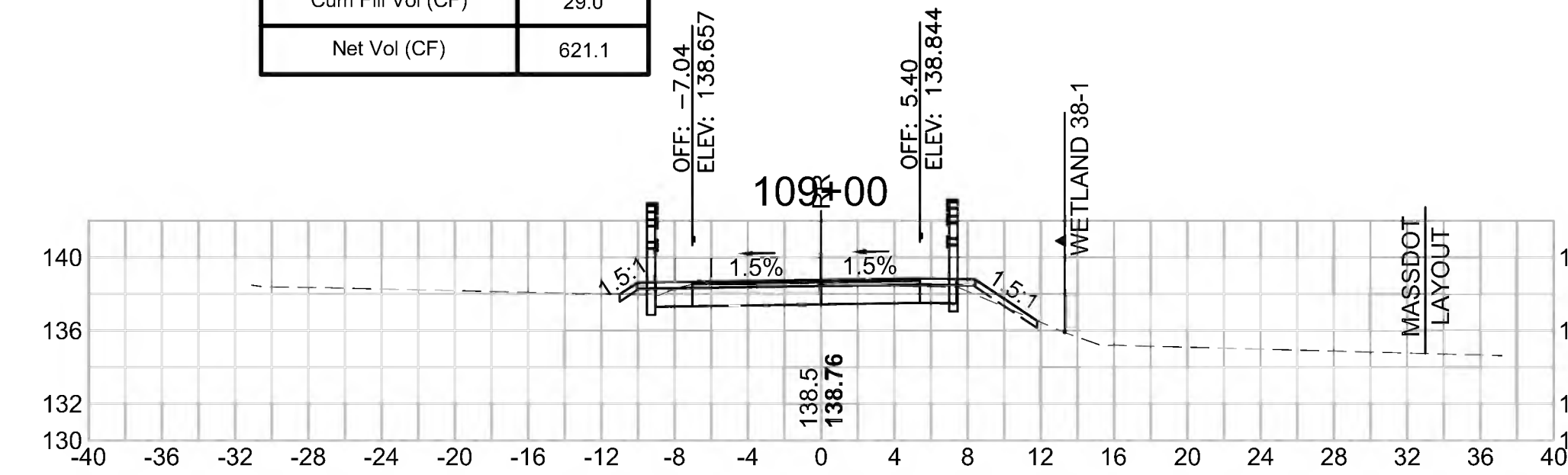

Total Volume at Station 105+50.00

Cut Area (SF)	38.054
Fill Area (SF)	0.000
Cut Vol (CF)	70.049
Fill Vol (CF)	0.0
Cum Cut Vol (CF)	340.403
Cum Fill Vol (CF)	20.5
Net Vol (CF)	319.9

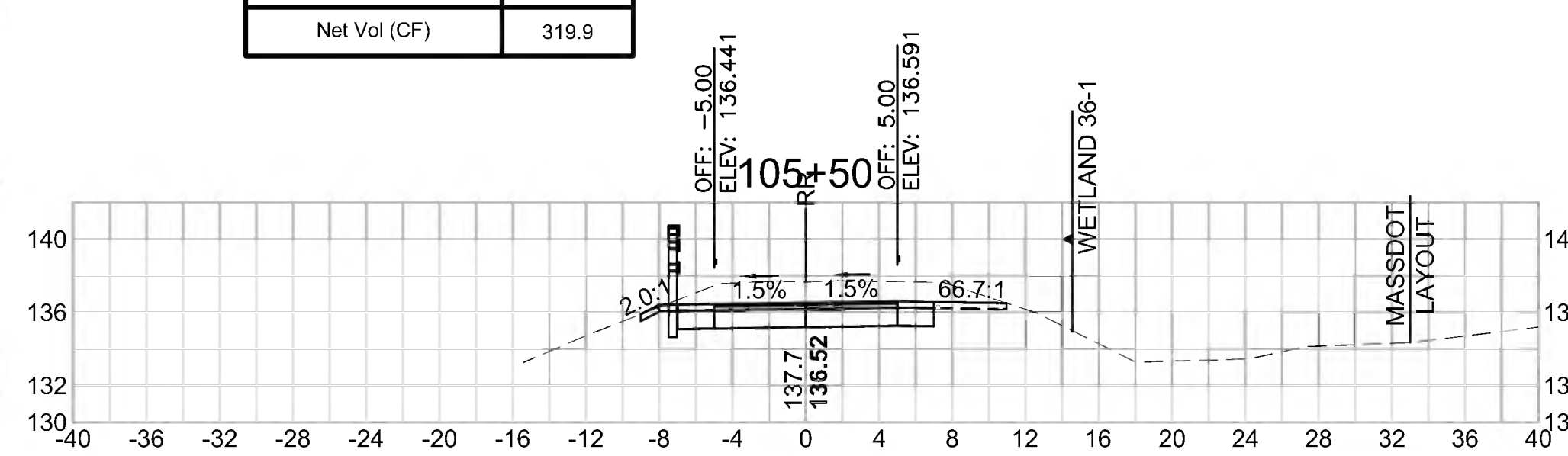

Total Volume at Station 107+00.00

Cut Area (SF)	20.740
Fill Area (SF)	1.333
Cut Vol (CF)	39.980
Fill Vol (CF)	3.8
Cum Cut Vol (CF)	494.056
Cum Fill Vol (CF)	26.8
Net Vol (CF)	467.3

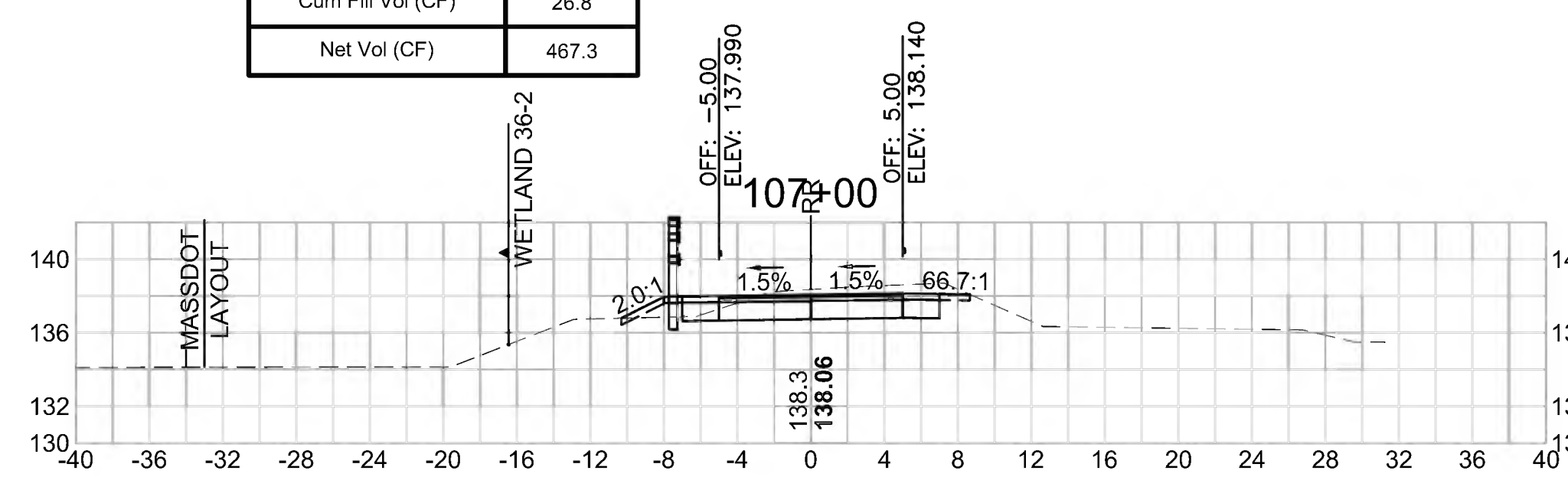

Total Volume at Station 108+50.00

Cut Area (SF)	27.396
Fill Area (SF)	0.000
Cut Vol (CF)	41.283
Fill Vol (CF)	0.0
Cum Cut Vol (CF)	608.014
Cum Fill Vol (CF)	28.0
Net Vol (CF)	580.0

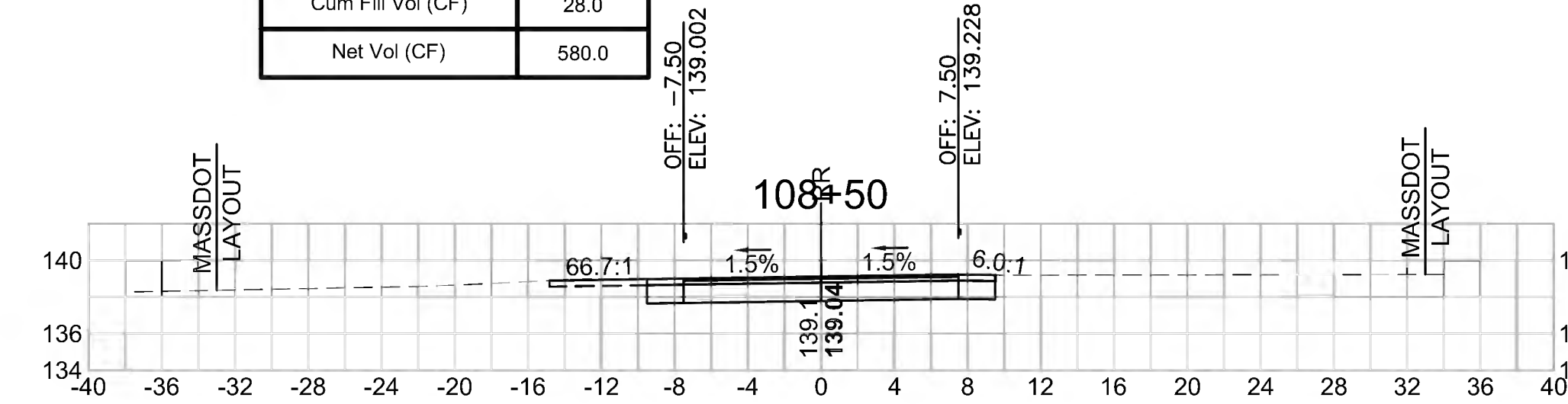

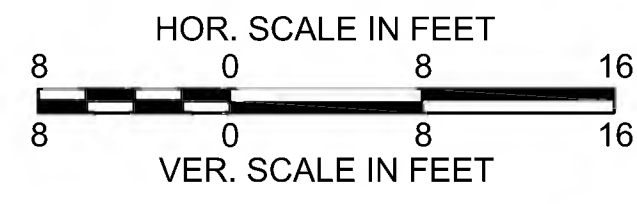

SUDBURY
 BRUCE FREEMAN RAIL TRAIL

STATE	FED. AID PROJ. NO.	SHEET NO.	TOTAL SHEETS
MA	XXX-XXX(XXX)X	247	319

PROJECT FILE NO. 608164

CROSS SECTIONS

Total Volume at Station 111+00.00

Cut Area (SF)	18.055
Fill Area (SF)	0.000
Cut Vol (CF)	40.035
Fill Vol (CF)	0.0
Cum Cut Vol (CF)	848.287
Cum Fill Vol (CF)	30.0
Net Vol (CF)	818.3

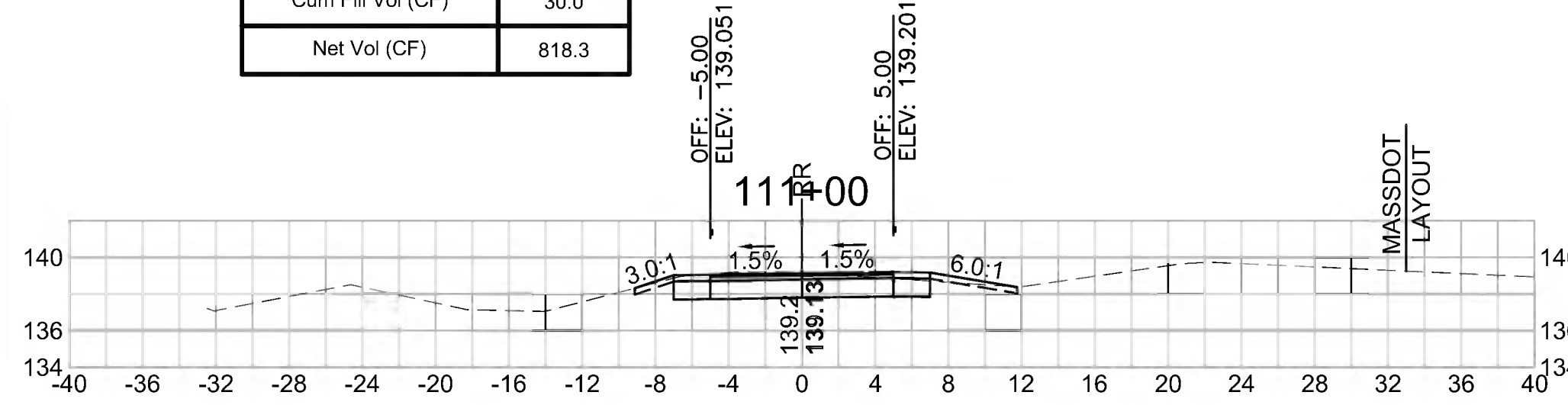

Total Volume at Station 112+50.00

Cut Area (SF)	0.390
Fill Area (SF)	43.694
Cut Vol (CF)	0.714
Fill Vol (CF)	63.5
Cum Cut Vol (CF)	874.526
Cum Fill Vol (CF)	130.0
Net Vol (CF)	744.6

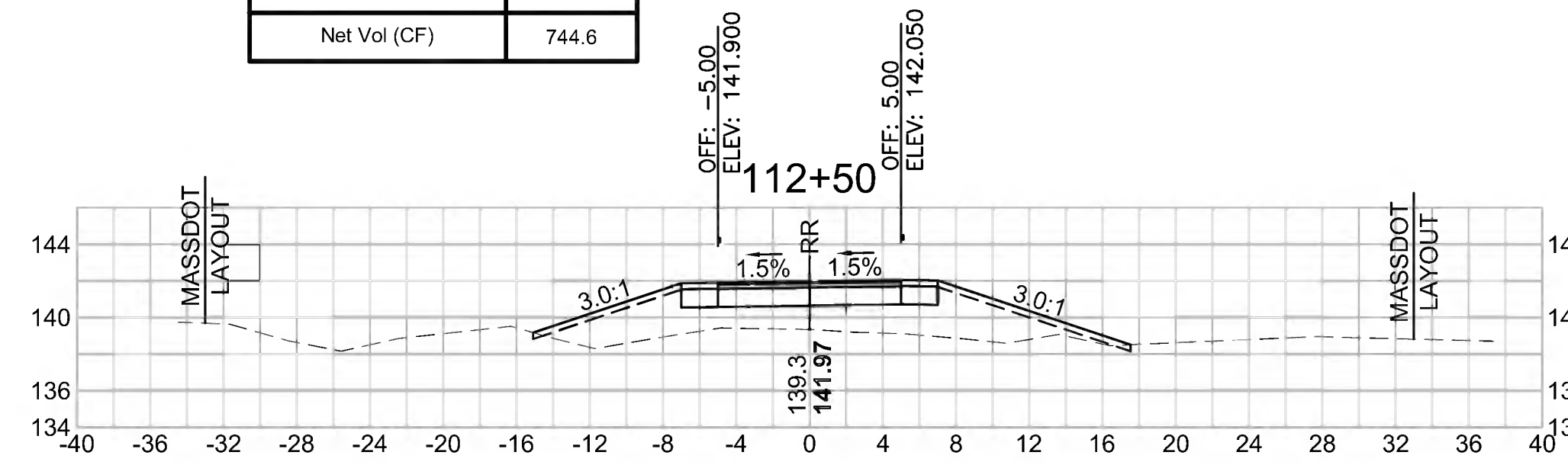

Total Volume at Station 114+00.00

Cut Area (SF)	0.282
Fill Area (SF)	148.843
Cut Vol (CF)	0.599
Fill Vol (CF)	160.4
Cum Cut Vol (CF)	876.451
Cum Fill Vol (CF)	436.6
Net Vol (CF)	439.8

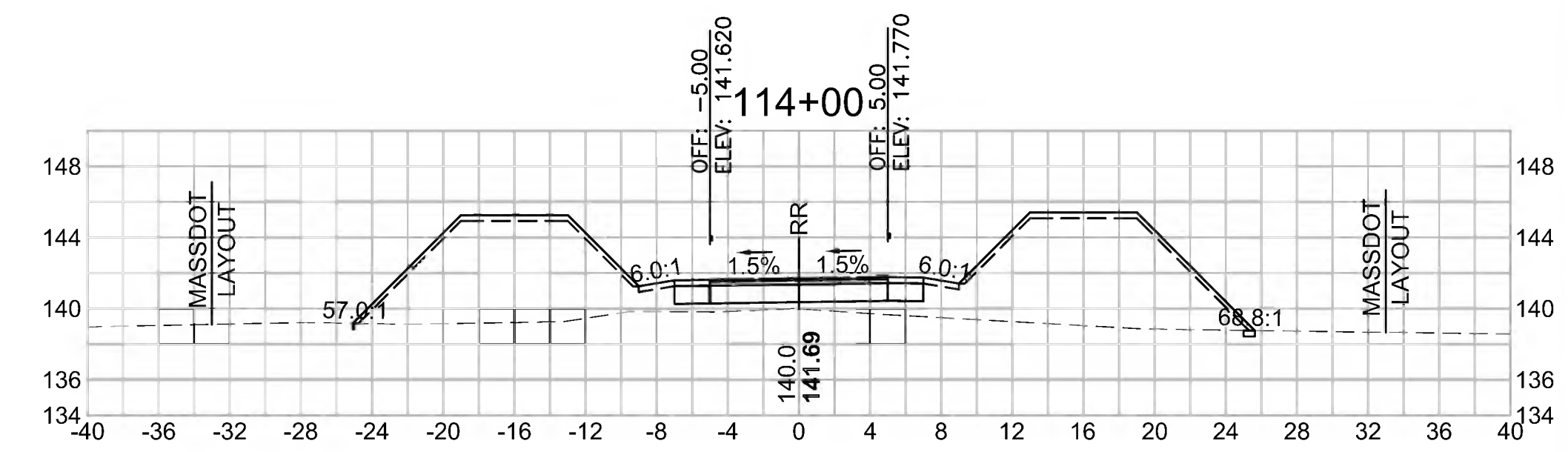

Total Volume at Station 110+50.00

Cut Area (SF)	25.183
Fill Area (SF)	0.000
Cut Vol (CF)	52.790
Fill Vol (CF)	0.0
Cum Cut Vol (CF)	808.252
Cum Fill Vol (CF)	30.0
Net Vol (CF)	778.2

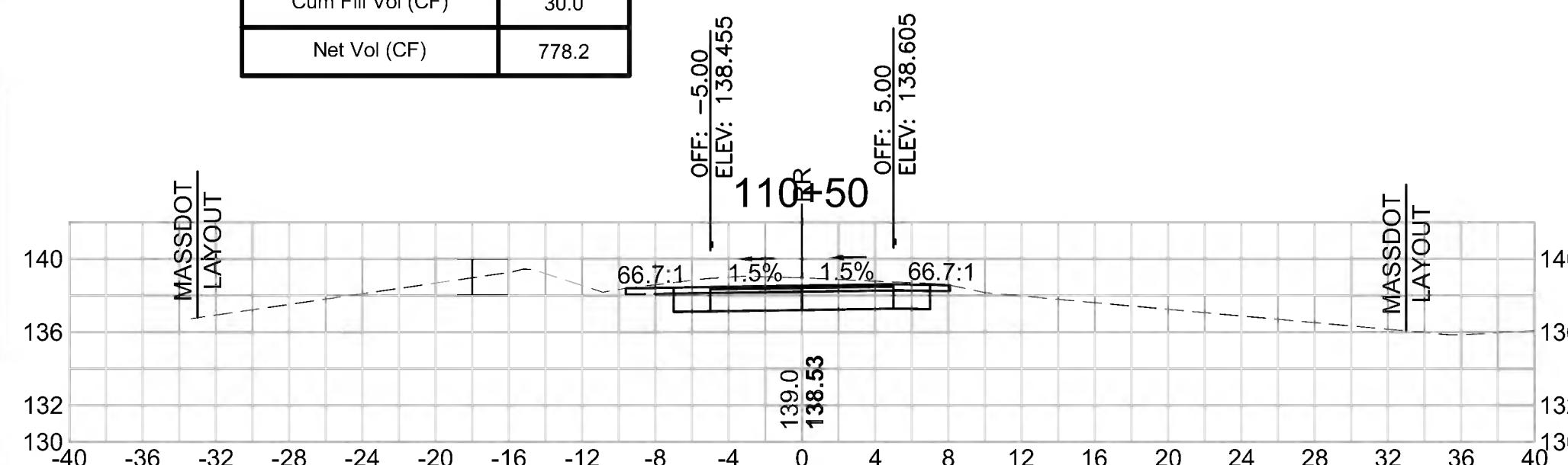

Total Volume at Station 112+00.00

Cut Area (SF)	0.381
Fill Area (SF)	24.924
Cut Vol (CF)	4.581
Fill Vol (CF)	29.7
Cum Cut Vol (CF)	873.812
Cum Fill Vol (CF)	66.4
Net Vol (CF)	807.4

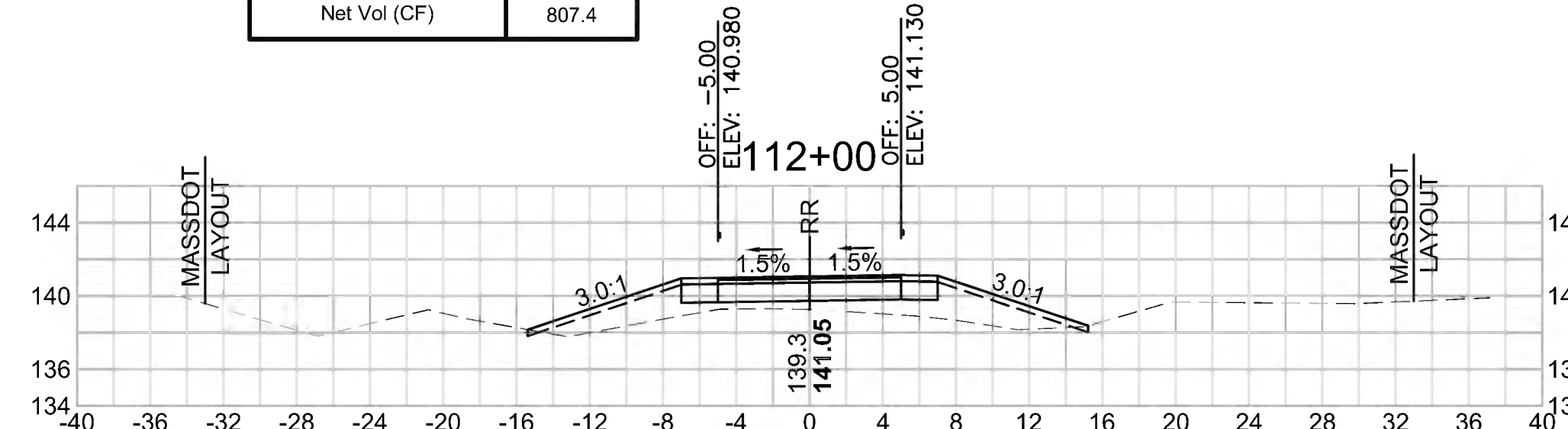

Total Volume at Station 113+50.00

Cut Area (SF)	0.364
Fill Area (SF)	24.397
Cut Vol (CF)	0.652
Fill Vol (CF)	64.2
Cum Cut Vol (CF)	875.853
Cum Fill Vol (CF)	276.2
Net Vol (CF)	599.7

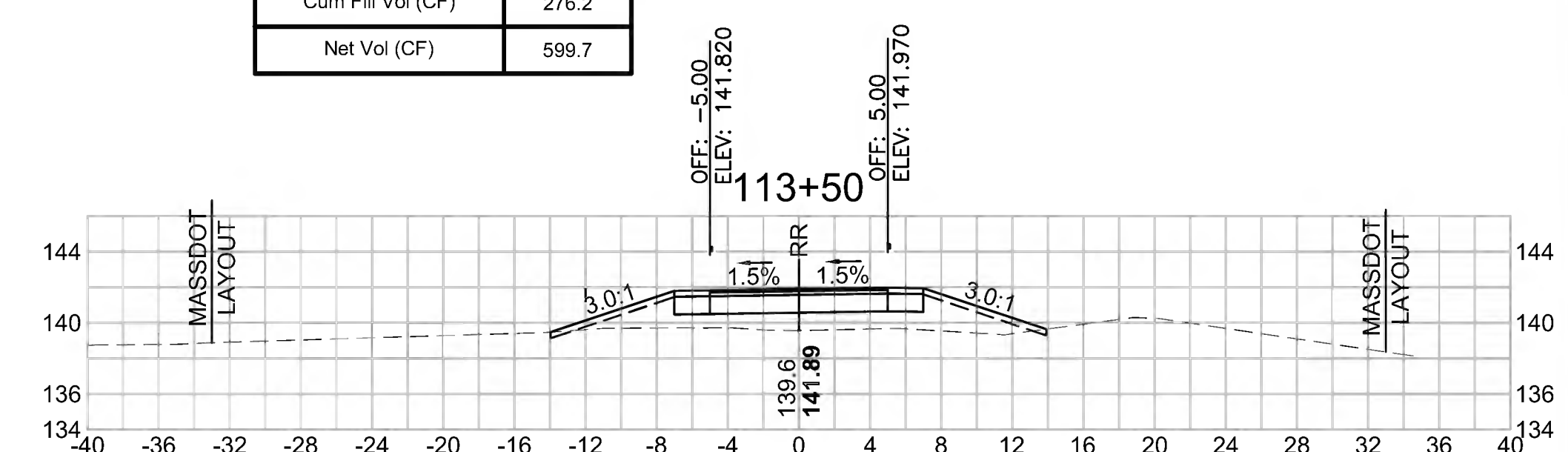

Total Volume at Station 110+00.00

Cut Area (SF)	31.830
Fill Area (SF)	0.000
Cut Vol (CF)	59.036
Fill Vol (CF)	0.0
Cum Cut Vol (CF)	755.462
Cum Fill Vol (CF)	30.0
Net Vol (CF)	725.4

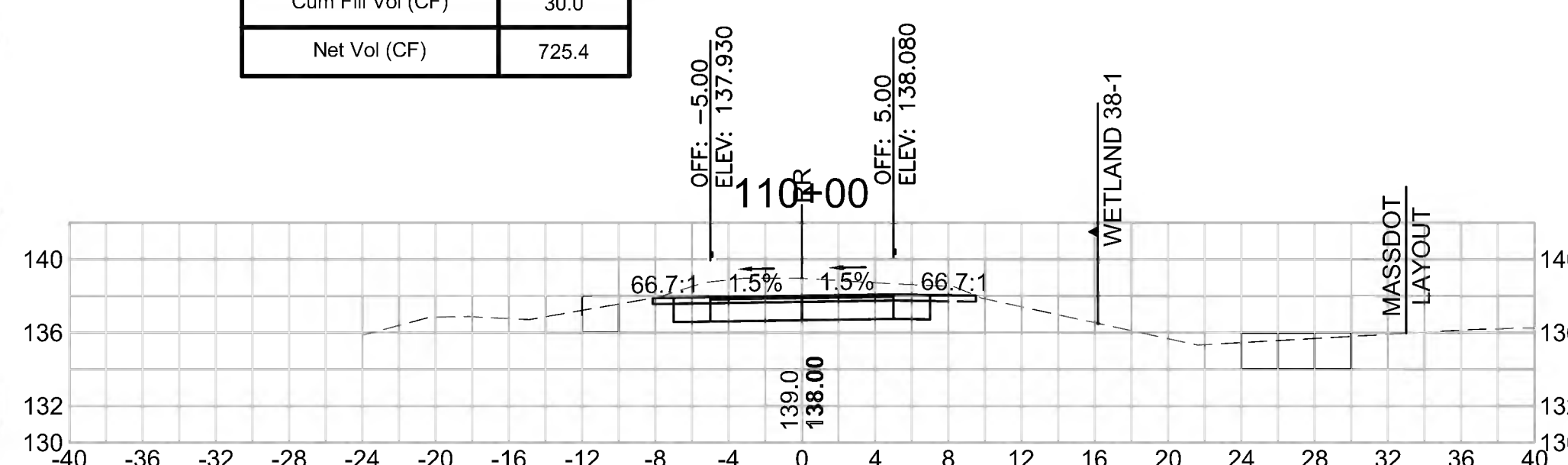

Total Volume at Station 111+50.00

Cut Area (SF)	4.565
Fill Area (SF)	7.194
Cut Vol (CF)	20.945
Fill Vol (CF)	6.7
Cum Cut Vol (CF)	869.232
Cum Fill Vol (CF)	36.7
Net Vol (CF)	832.5

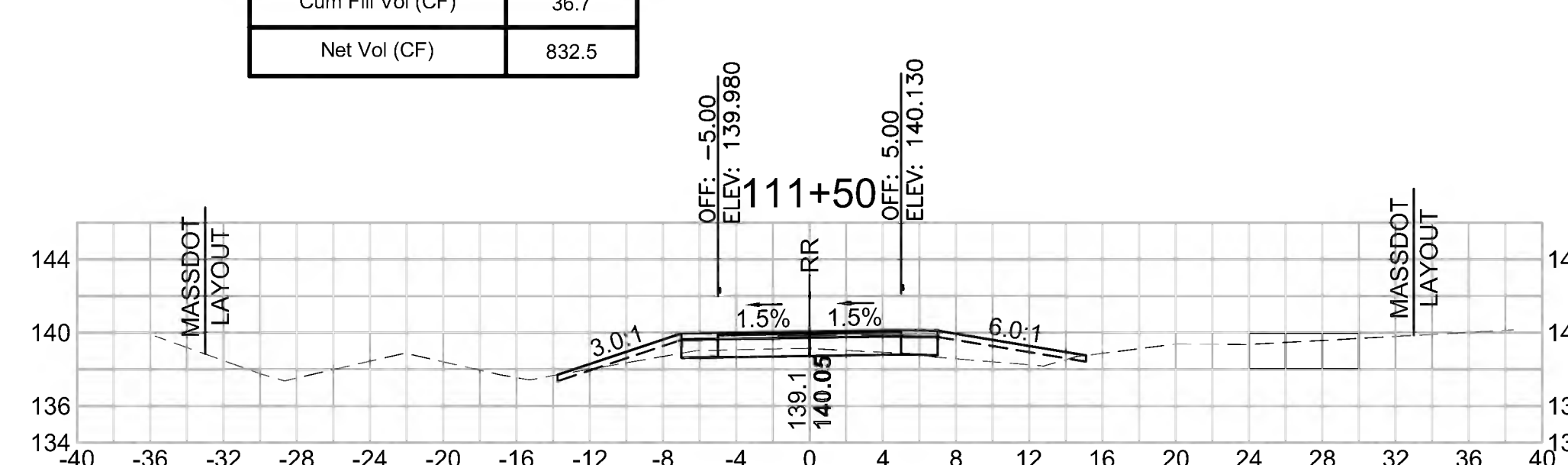

Total Volume at Station 113+00.00

Cut Area (SF)	0.340
Fill Area (SF)	44.923
Cut Vol (CF)	0.676
Fill Vol (CF)	82.1
Cum Cut Vol (CF)	875.201
Cum Fill Vol (CF)	212.0
Net Vol (CF)	663.2

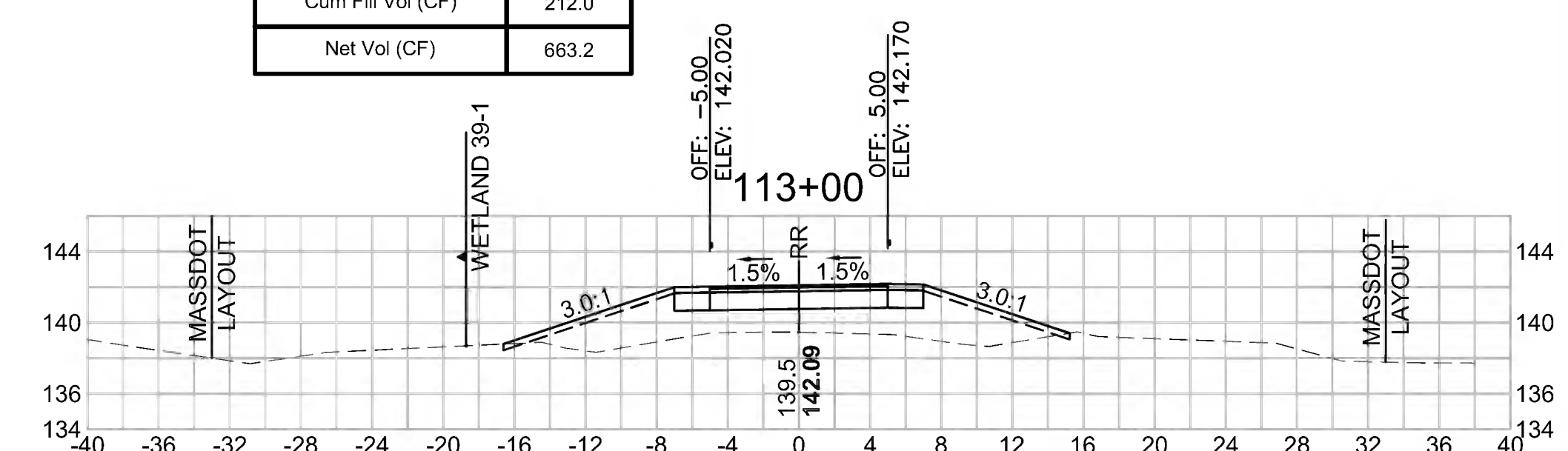

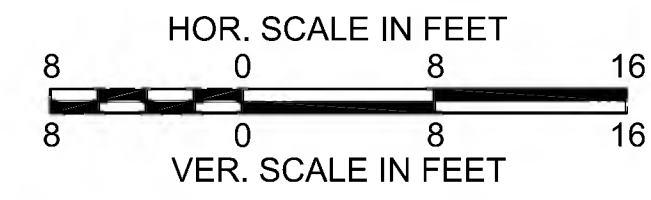

**SUDBURY
 BRUCE FREEMAN RAIL TRAIL**

STATE	FED. AID PROJ. NO.	SHEET NO.	TOTAL SHEETS
MA	XXX-XXXX(XXX)X	248	319

PROJECT FILE NO. 608164

CROSS SECTIONS

608164_XSEC(CROSS SECTION LAYOUTS).DWG 18-Feb-2022

Total Volume at Station 115+50.00

Cut Area (SF)	6.410
Fill Area (SF)	62.442
Cut Vol (CF)	6.873
Fill Vol (CF)	157.1
Cum Cut Vol (CF)	885.341
Cum Fill Vol (CF)	1072.8
Net Vol (CF)	-187.5

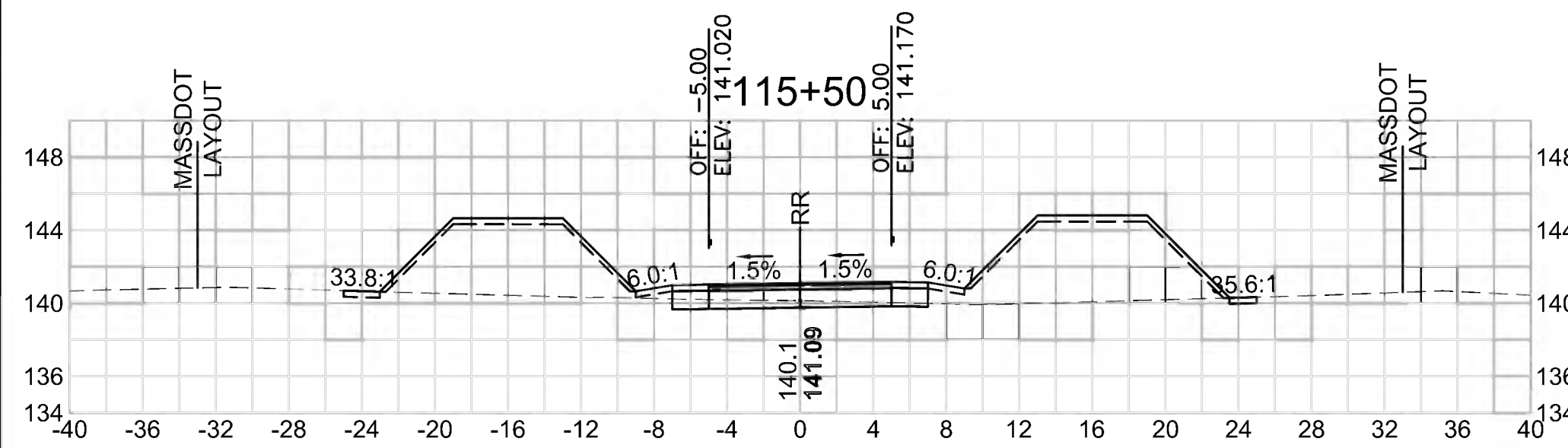

Total Volume at Station 117+00.00

Cut Area (SF)	14.722
Fill Area (SF)	62.885
Cut Vol (CF)	27.869
Fill Vol (CF)	94.0
Cum Cut Vol (CF)	976.067
Cum Fill Vol (CF)	1260.5
Net Vol (CF)	-284.4

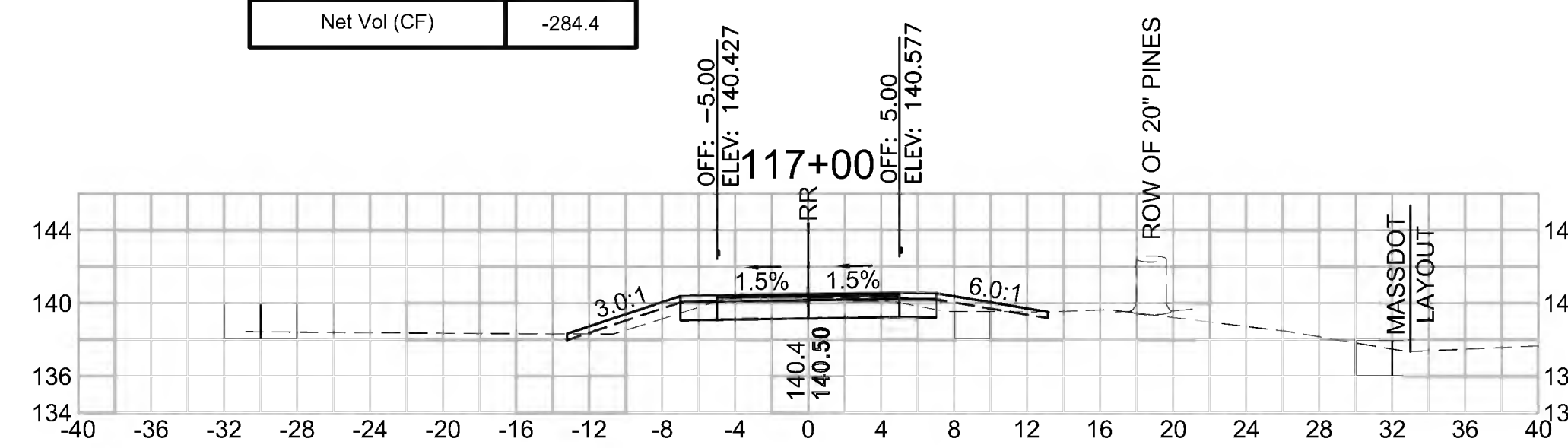

Total Volume at Station 118+50.00

Cut Area (SF)	29.627
Fill Area (SF)	0.000
Cut Vol (CF)	50.928
Fill Vol (CF)	0.0
Cum Cut Vol (CF)	1099.492
Cum Fill Vol (CF)	1436.6
Net Vol (CF)	-337.1

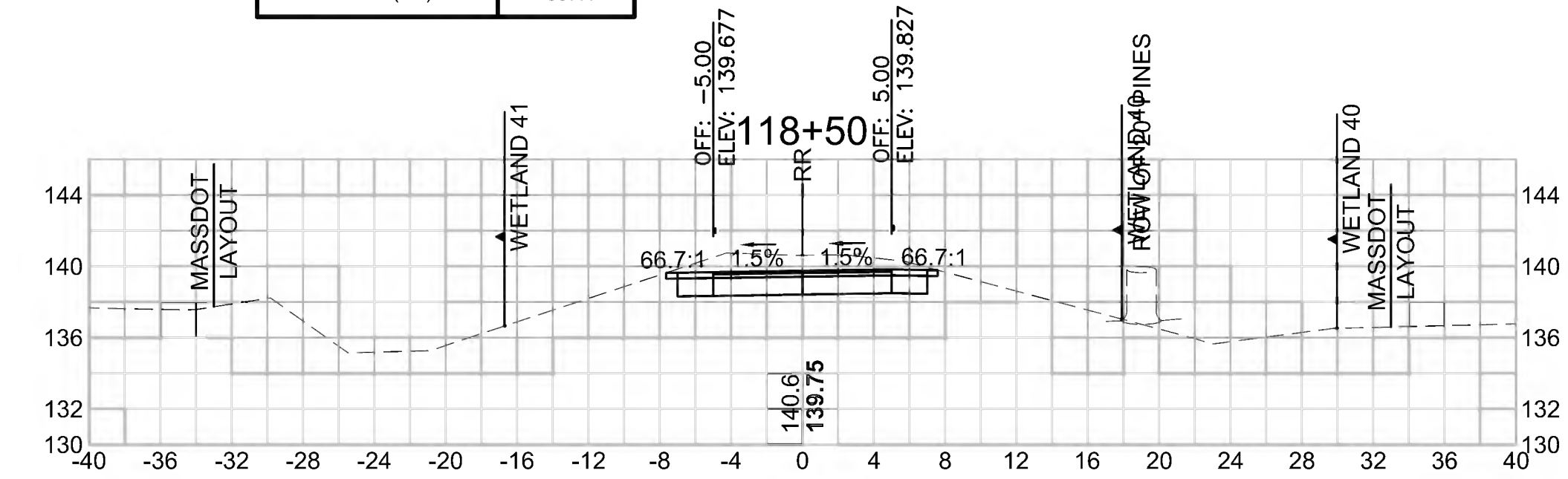

Total Volume at Station 115+00.00

Cut Area (SF)	1.012
Fill Area (SF)	107.174
Cut Vol (CF)	1.347
Fill Vol (CF)	220.3
Cum Cut Vol (CF)	878.468
Cum Fill Vol (CF)	915.8
Net Vol (CF)	-37.3

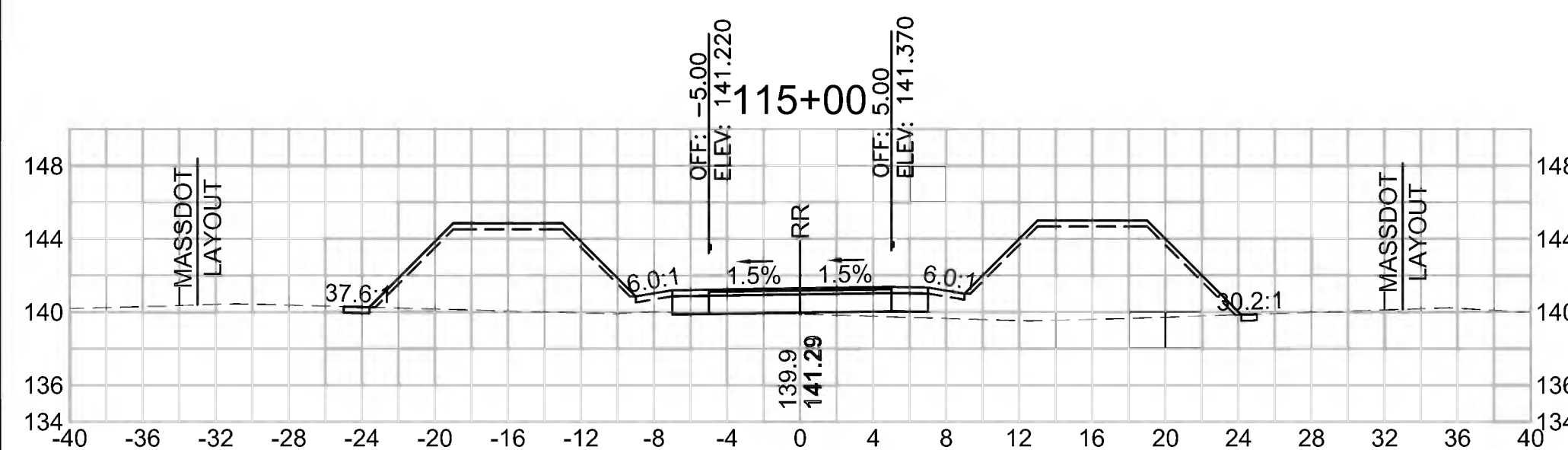

Total Volume at Station 116+50.00

Cut Area (SF)	15.376
Fill Area (SF)	38.671
Cut Vol (CF)	35.580
Fill Vol (CF)	35.8
Cum Cut Vol (CF)	948.198
Cum Fill Vol (CF)	1166.5
Net Vol (CF)	-218.3

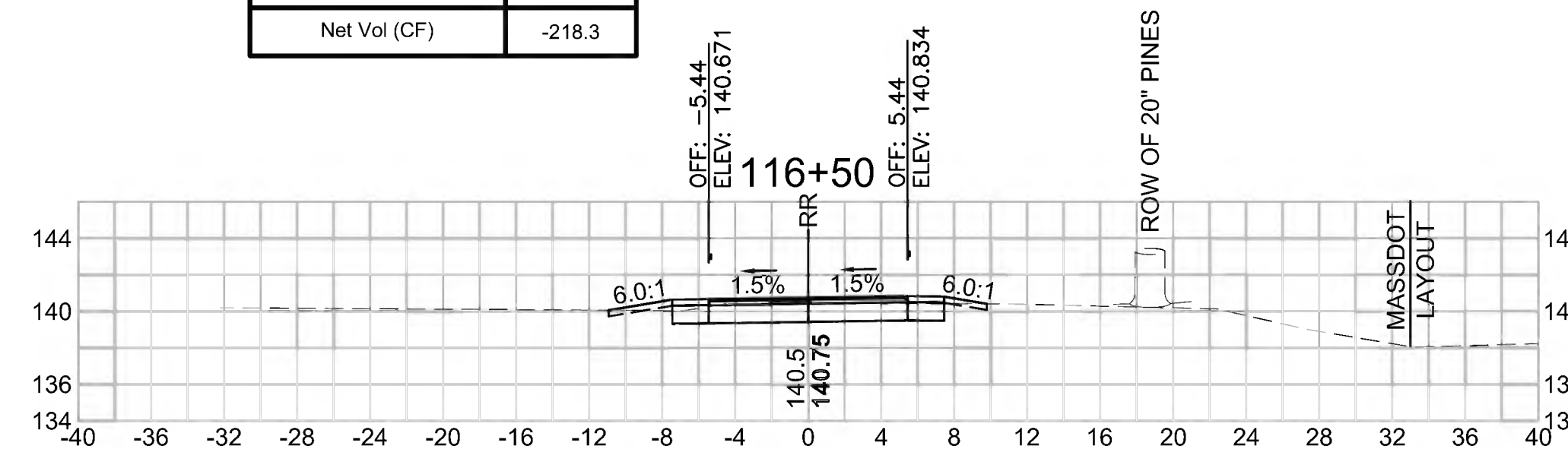

Total Volume at Station 118+00.00

Cut Area (SF)	25.374
Fill Area (SF)	0.000
Cut Vol (CF)	41.181
Fill Vol (CF)	59.0
Cum Cut Vol (CF)	1048.565
Cum Fill Vol (CF)	1436.6
Net Vol (CF)	-388.1

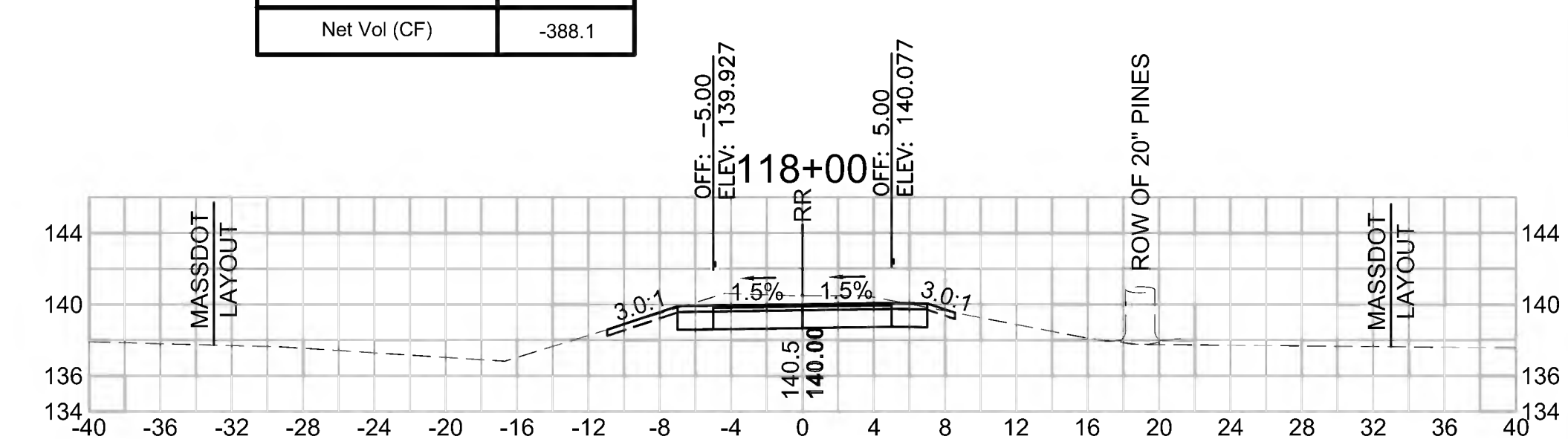

Total Volume at Station 114+50.00

Cut Area (SF)	0.442
Fill Area (SF)	130.746
Cut Vol (CF)	0.671
Fill Vol (CF)	258.9
Cum Cut Vol (CF)	877.122
Cum Fill Vol (CF)	695.5
Net Vol (CF)	181.6

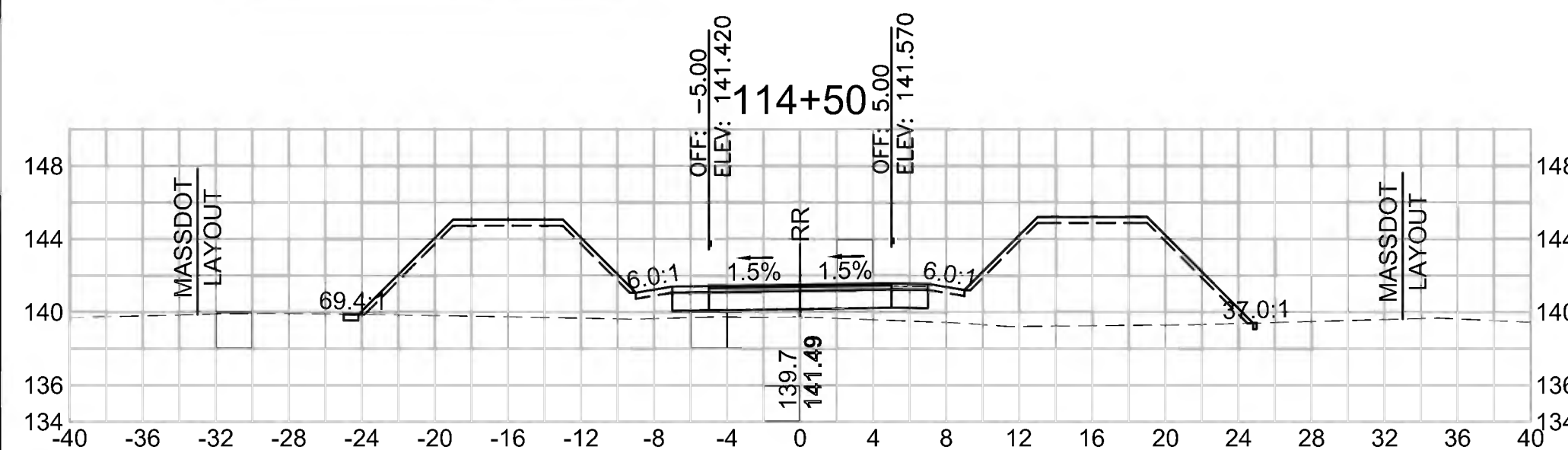

Total Volume at Station 116+00.00

Cut Area (SF)	23.050
Fill Area (SF)	0.000
Cut Vol (CF)	27.278
Fill Vol (CF)	57.8
Cum Cut Vol (CF)	912.618
Cum Fill Vol (CF)	1130.6
Net Vol (CF)	-218.0

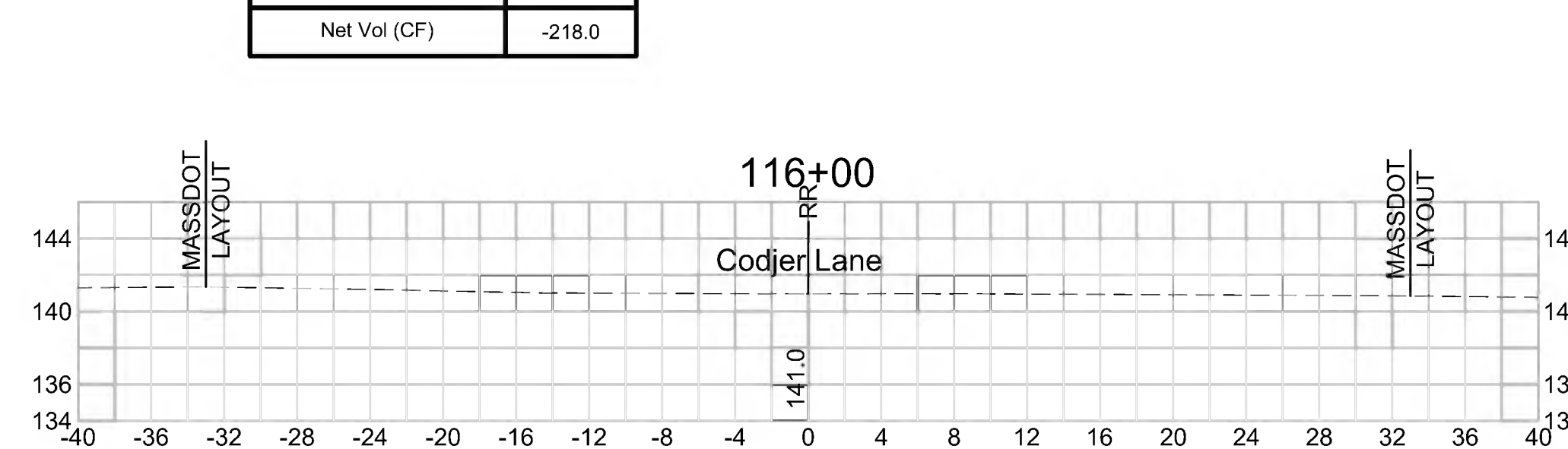

Total Volume at Station 117+50.00

Cut Area (SF)	19.101
Fill Area (SF)	63.669
Cut Vol (CF)	31.318
Fill Vol (CF)	117.2
Cum Cut Vol (CF)	1007.384
Cum Fill Vol (CF)	1377.7
Net Vol (CF)	-370.3

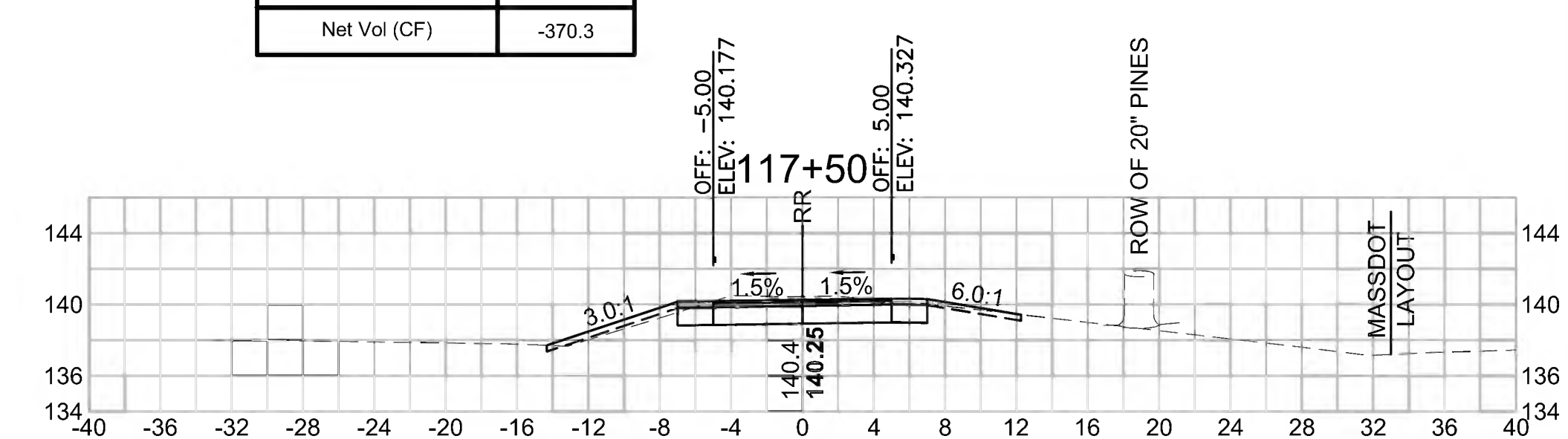

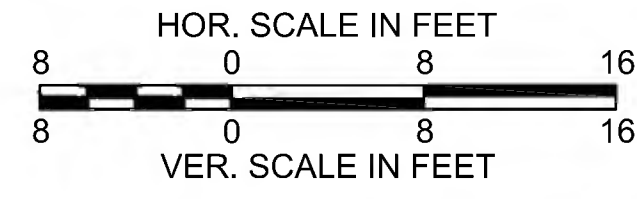

SUDBURY
BRUCE FREEMAN RAIL TRAIL

STATE	FED. AID PROJ. NO.	SHEET NO.	TOTAL SHEETS
MA	XXX-XXXX(XXX)X	249	319

PROJECT FILE NO. 608164

CROSS SECTIONS

608164_XSEC(CROSS SECTION LAYOUTS).DWG 18-Feb-2022

Total Volume at Station 120+00.00

Cut Area (SF)	35.161
Fill Area (SF)	0.000
Cut Vol (CF)	63.024
Fill Vol (CF)	0.0
Cum Cut Vol (CF)	1276.482
Cum Fill Vol (CF)	1436.6
Net Vol (CF)	-160.1

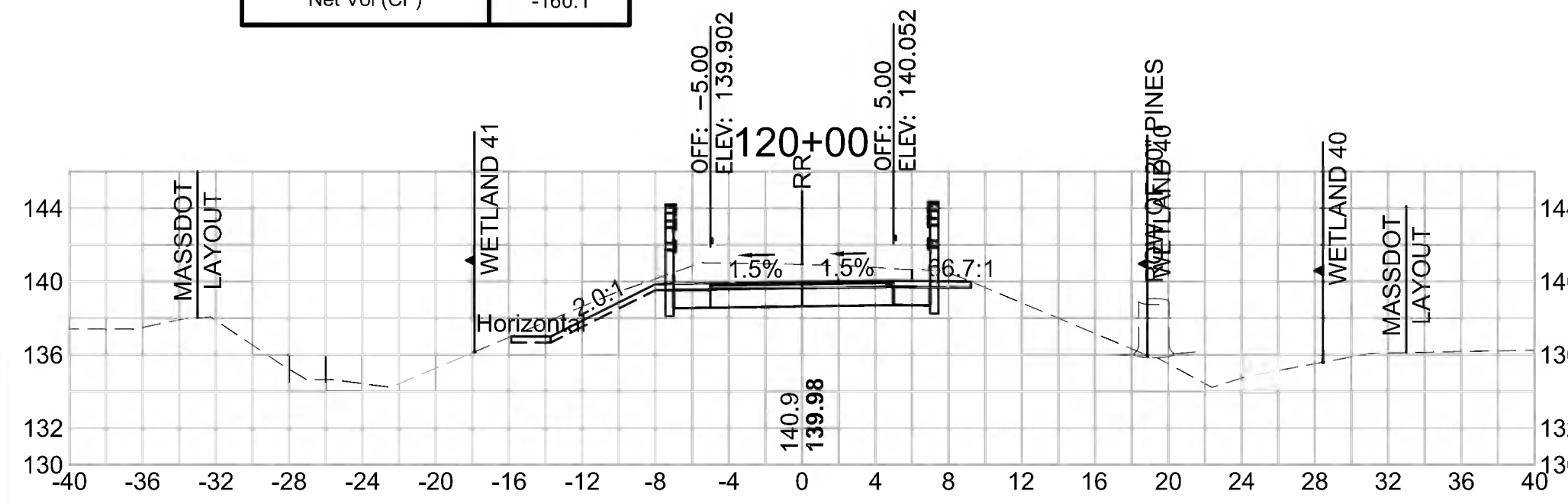

Total Volume at Station 121+50.00

Cut Area (SF)	35.322
Fill Area (SF)	0.000
Cut Vol (CF)	65.465
Fill Vol (CF)	0.0
Cum Cut Vol (CF)	1472.639
Cum Fill Vol (CF)	1436.6
Net Vol (CF)	36.0

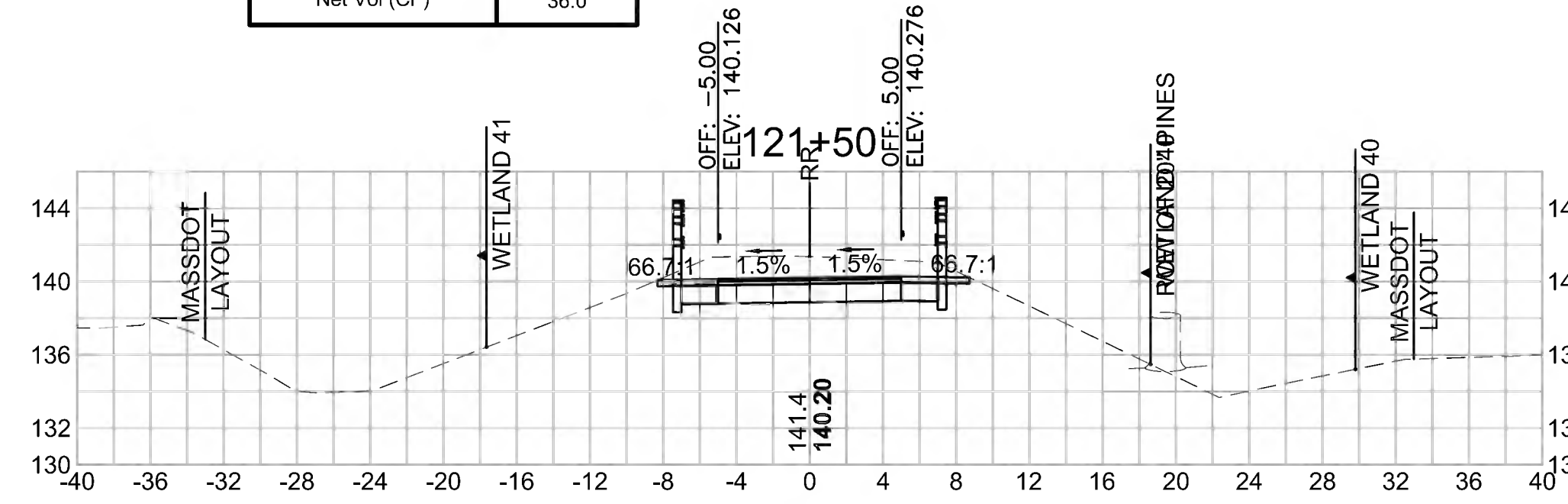

Total Volume at Station 123+00.00

Cut Area (SF)	34.476
Fill Area (SF)	0.000
Cut Vol (CF)	64.981
Fill Vol (CF)	0.0
Cum Cut Vol (CF)	1667.972
Cum Fill Vol (CF)	1436.6
Net Vol (CF)	231.4

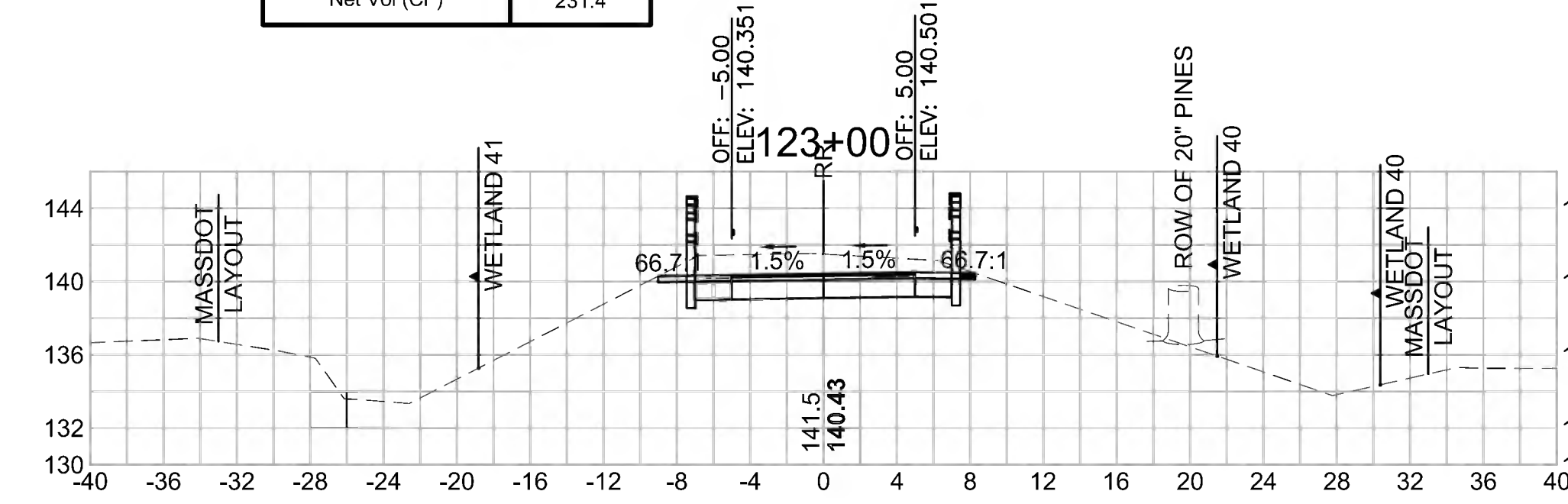

Total Volume at Station 119+50.00

Cut Area (SF)	32.904
Fill Area (SF)	0.000
Cut Vol (CF)	58.501
Fill Vol (CF)	0.0
Cum Cut Vol (CF)	1213.459
Cum Fill Vol (CF)	1436.6
Net Vol (CF)	-223.2

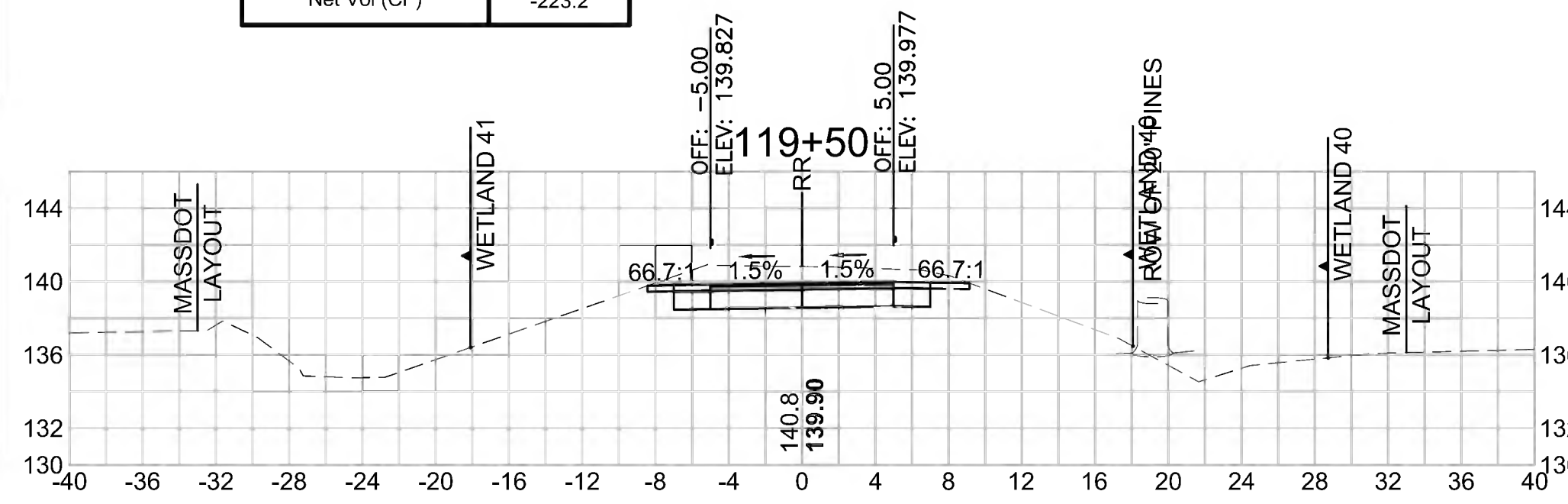

Total Volume at Station 121+00.00

Cut Area (SF)	35.379
Fill Area (SF)	0.000
Cut Vol (CF)	65.448
Fill Vol (CF)	0.0
Cum Cut Vol (CF)	1407.175
Cum Fill Vol (CF)	1436.6
Net Vol (CF)	-29.4

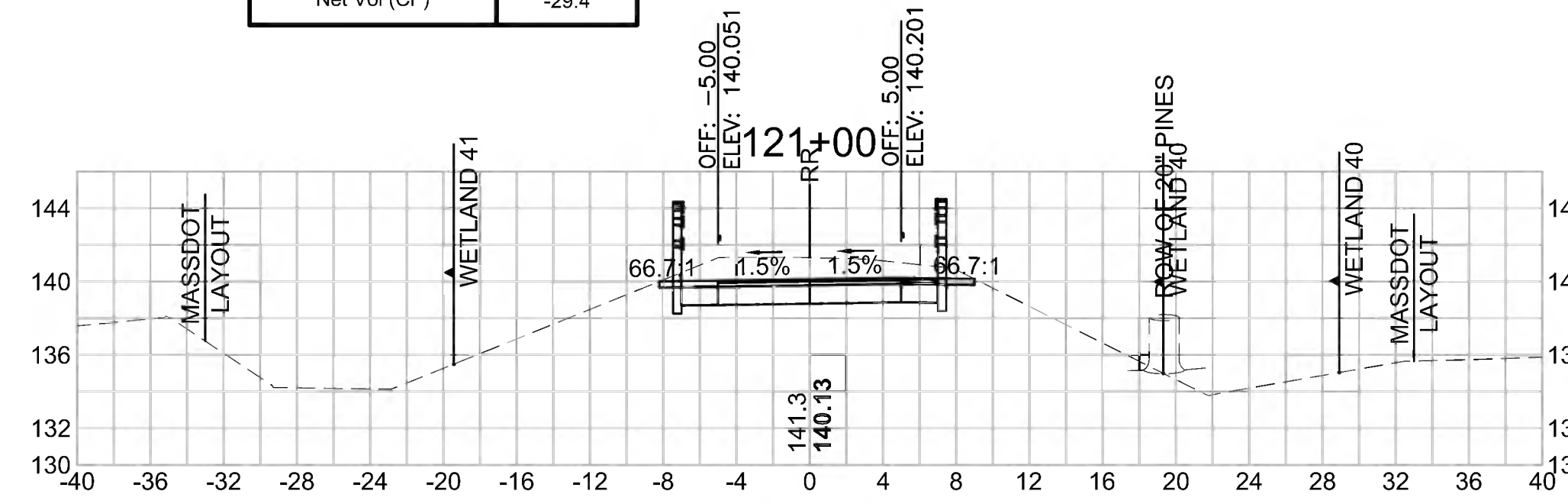

Total Volume at Station 122+50.00

Cut Area (SF)	35.703
Fill Area (SF)	0.000
Cut Vol (CF)	65.353
Fill Vol (CF)	0.0
Cum Cut Vol (CF)	1602.992
Cum Fill Vol (CF)	1436.6
Net Vol (CF)	166.4

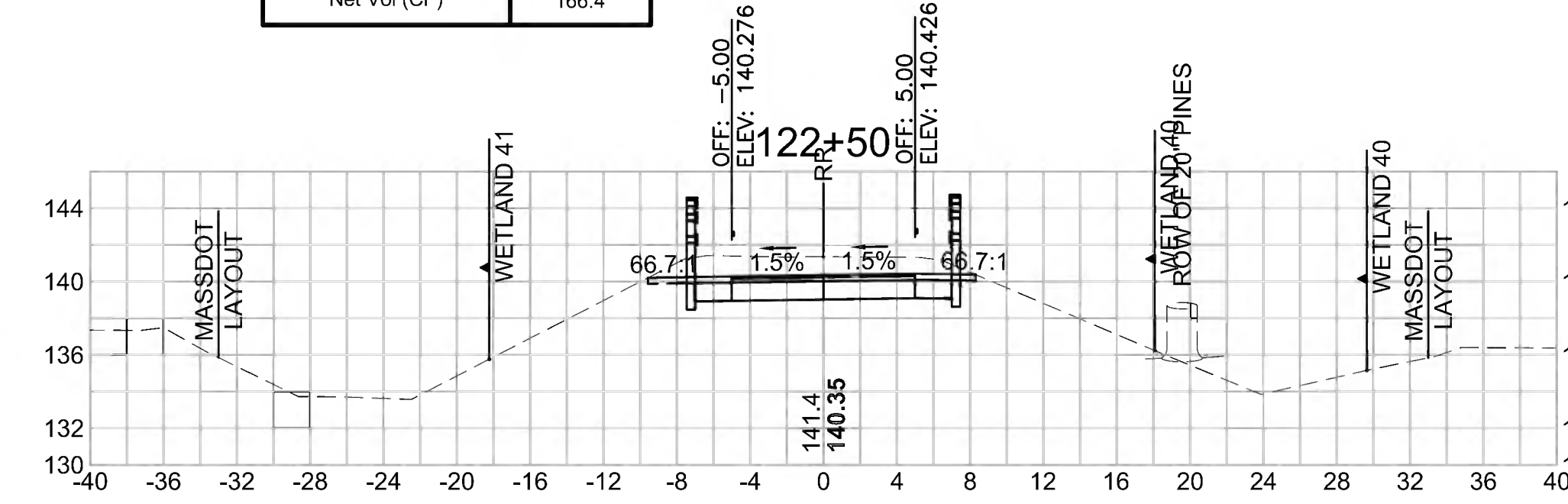

Total Volume at Station 119+00.00

Cut Area (SF)	30.276
Fill Area (SF)	0.000
Cut Vol (CF)	55.467
Fill Vol (CF)	0.0
Cum Cut Vol (CF)	1154.958
Cum Fill Vol (CF)	1436.6
Net Vol (CF)	-281.7

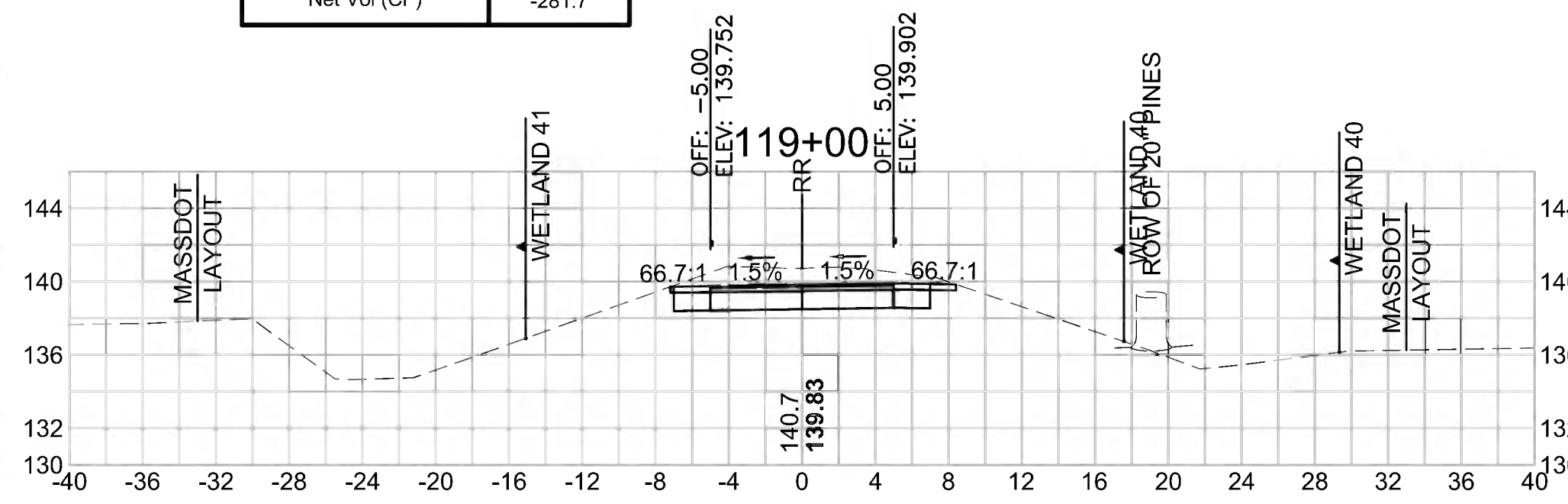

Total Volume at Station 120+50.00

Cut Area (SF)	35.305
Fill Area (SF)	0.000
Cut Vol (CF)	65.246
Fill Vol (CF)	0.0
Cum Cut Vol (CF)	1341.728
Cum Fill Vol (CF)	1436.6
Net Vol (CF)	-94.9

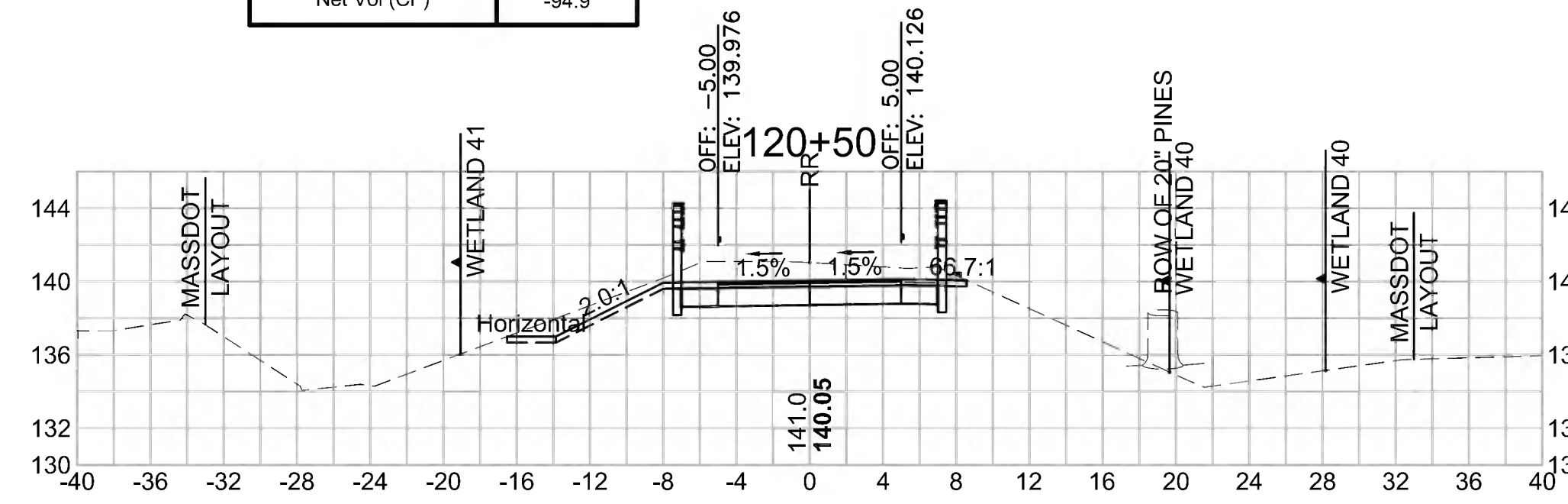

Total Volume at Station 122+00.00

Cut Area (SF)	34.878
Fill Area (SF)	0.000
Cut Vol (CF)	65.001
Fill Vol (CF)	0.0
Cum Cut Vol (CF)	1537.639
Cum Fill Vol (CF)	1436.6
Net Vol (CF)	101.0

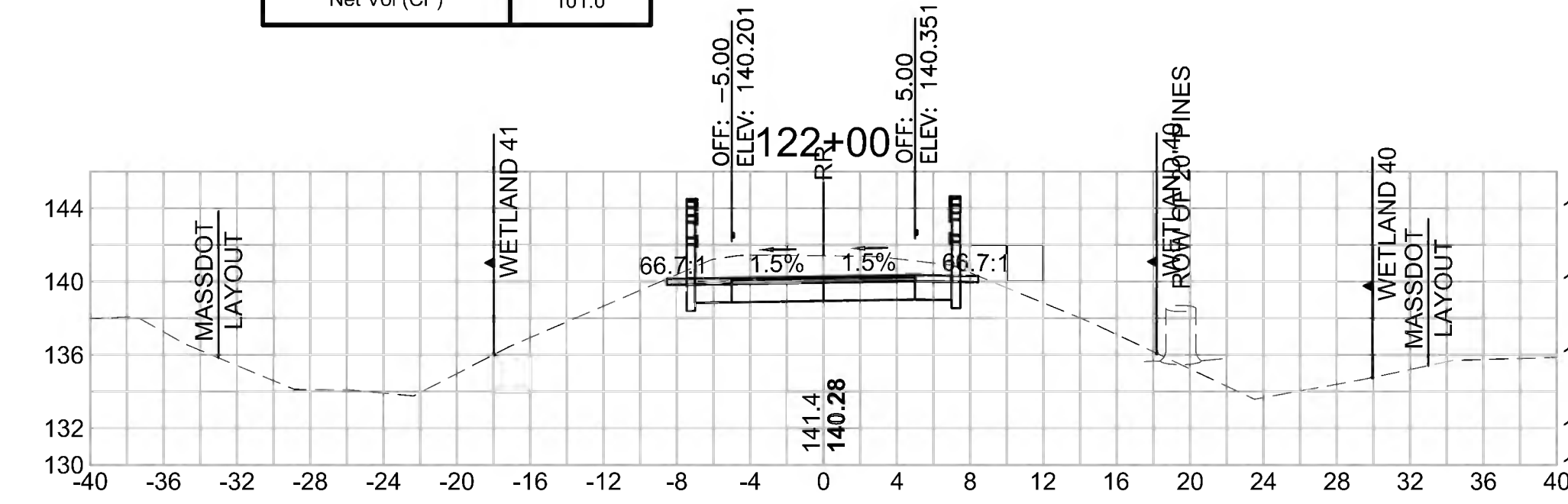

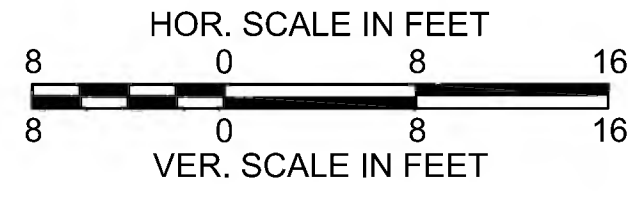

SUDBURY
 BRUCE FREEMAN RAIL TRAIL

STATE	FED. AID PROJ. NO.	SHEET NO.	TOTAL SHEETS
MA	XXX-XXXX(XXX)X	250	319
PROJECT FILE NO. 608164			

CROSS SECTIONS

Total Volume at Station 124+50.00

Cut Area (SF)	37.090
Fill Area (SF)	0.000
Cut Vol (CF)	68.327
Fill Vol (CF)	0.0
Cum Cut Vol (CF)	1866.161
Cum Fill Vol (CF)	1436.6
Net Vol (CF)	429.5

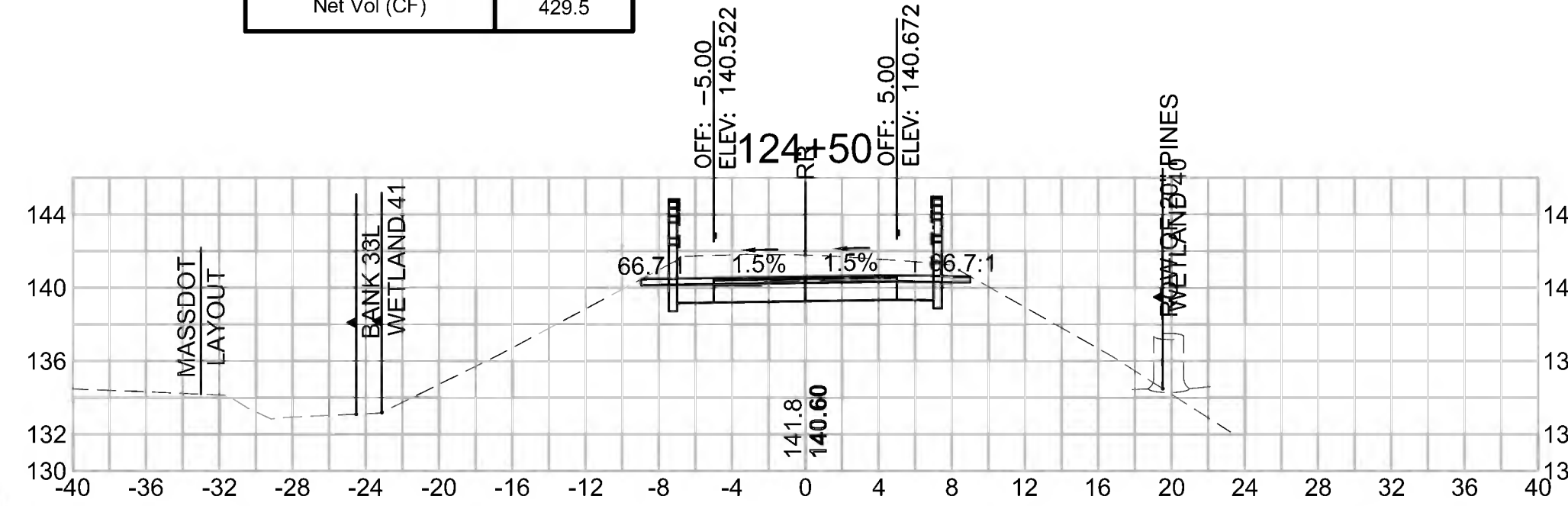

Total Volume at Station 126+00.00

Cut Area (SF)	58.889
Fill Area (SF)	0.000
Cut Vol (CF)	111.503
Fill Vol (CF)	0.0
Cum Cut Vol (CF)	2166.314
Cum Fill Vol (CF)	1436.6
Net Vol (CF)	729.7

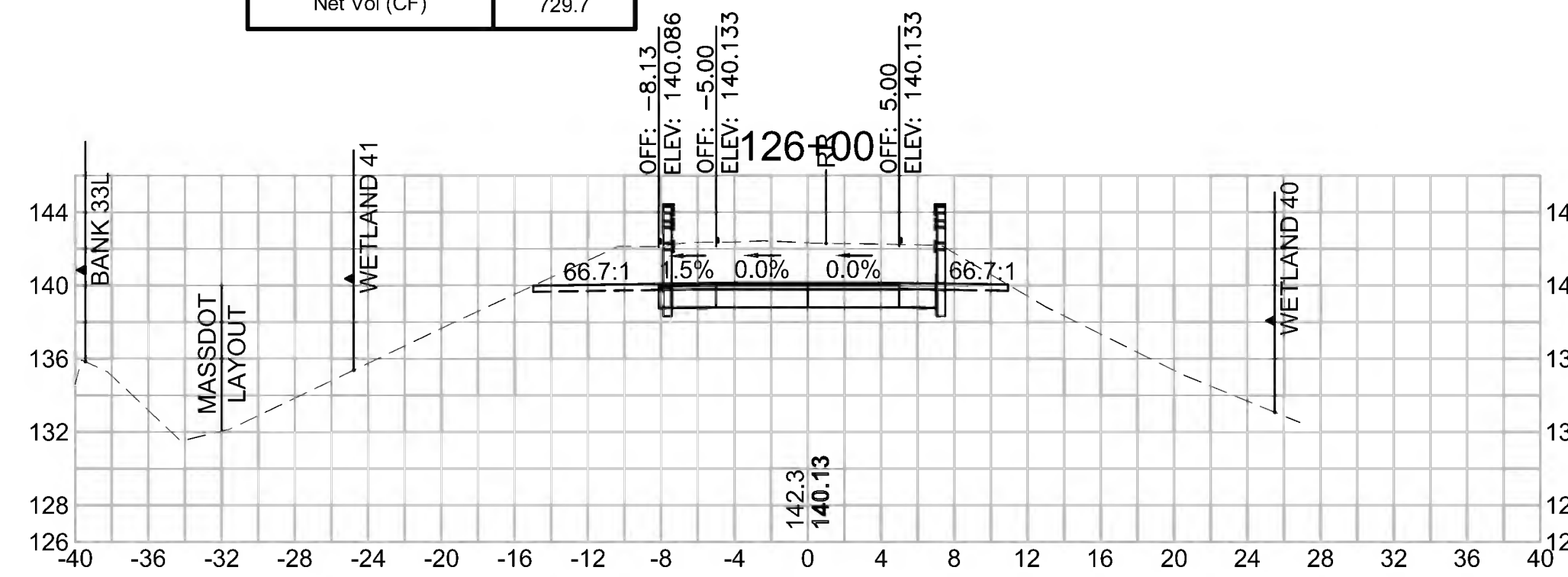

Total Volume at Station 127+50.00

Cut Area (SF)	22.655
Fill Area (SF)	0.000
Cut Vol (CF)	46.169
Fill Vol (CF)	0.0
Cum Cut Vol (CF)	2323.380
Cum Fill Vol (CF)	1442.5
Net Vol (CF)	880.9

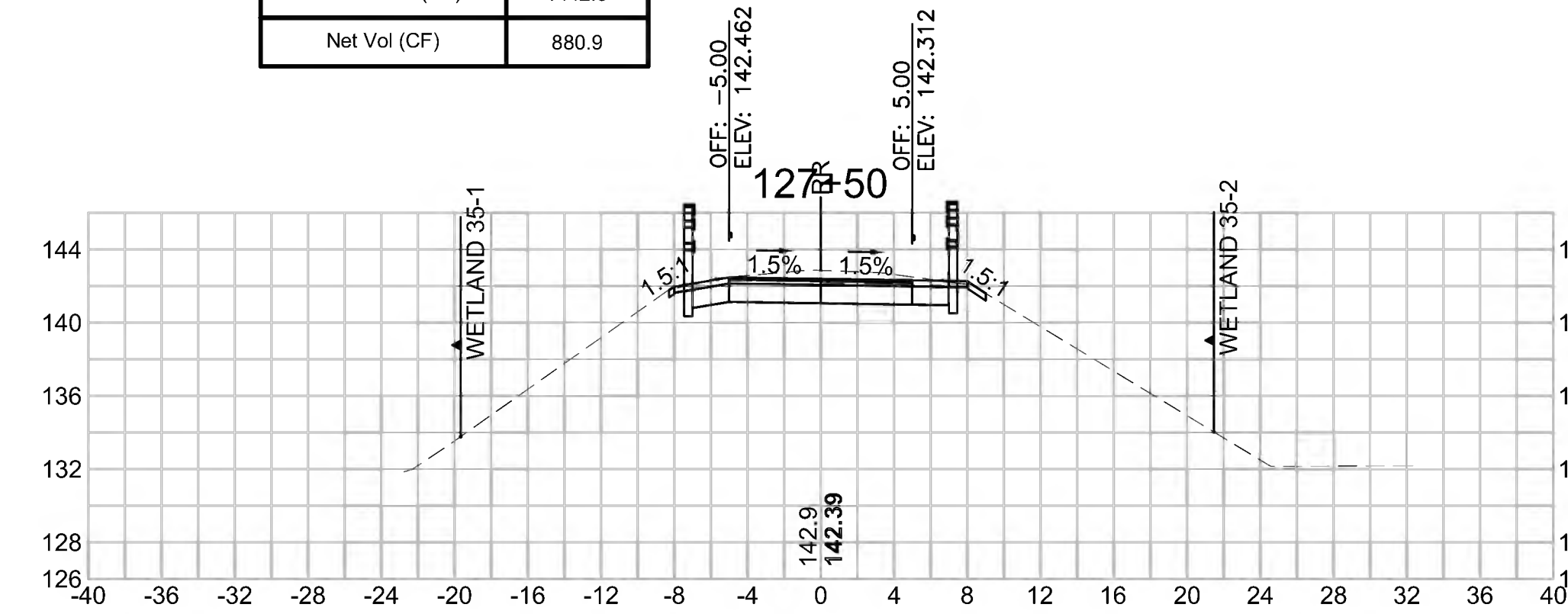

Total Volume at Station 124+00.00

Cut Area (SF)	36.702
Fill Area (SF)	0.000
Cut Vol (CF)	65.962
Fill Vol (CF)	0.0
Cum Cut Vol (CF)	1797.835
Cum Fill Vol (CF)	1436.6
Net Vol (CF)	361.2

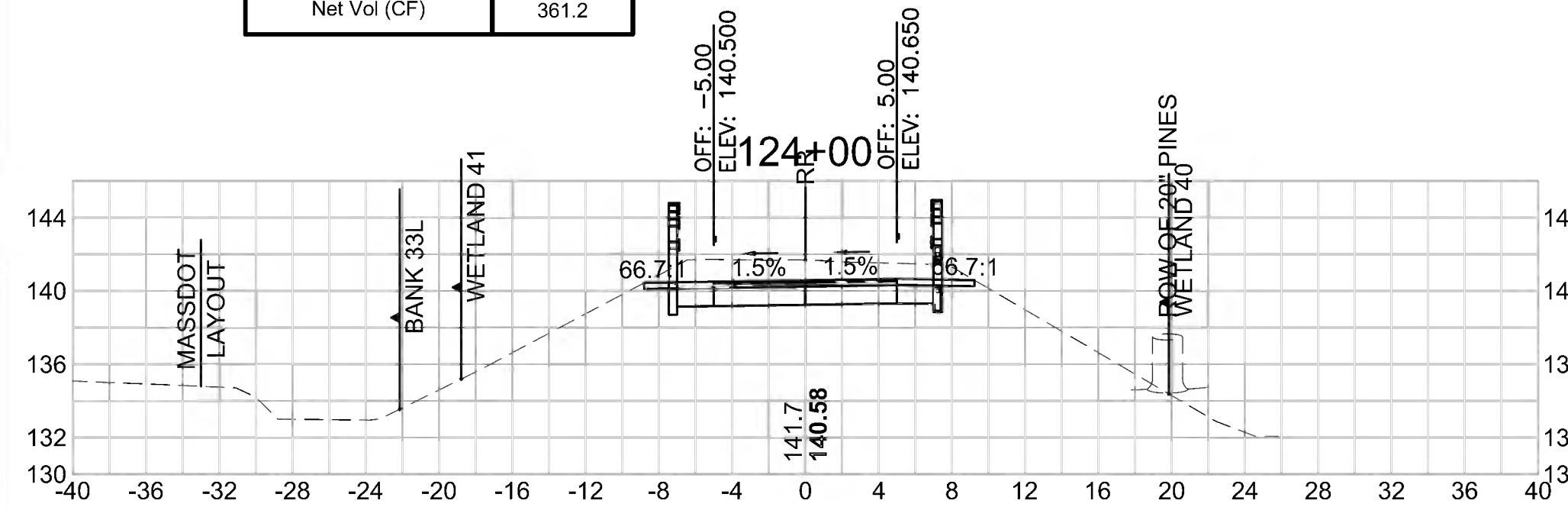

Total Volume at Station 125+50.00

Cut Area (SF)	61.534
Fill Area (SF)	0.000
Cut Vol (CF)	105.642
Fill Vol (CF)	0.0
Cum Cut Vol (CF)	2054.812
Cum Fill Vol (CF)	1436.6
Net Vol (CF)	618.2

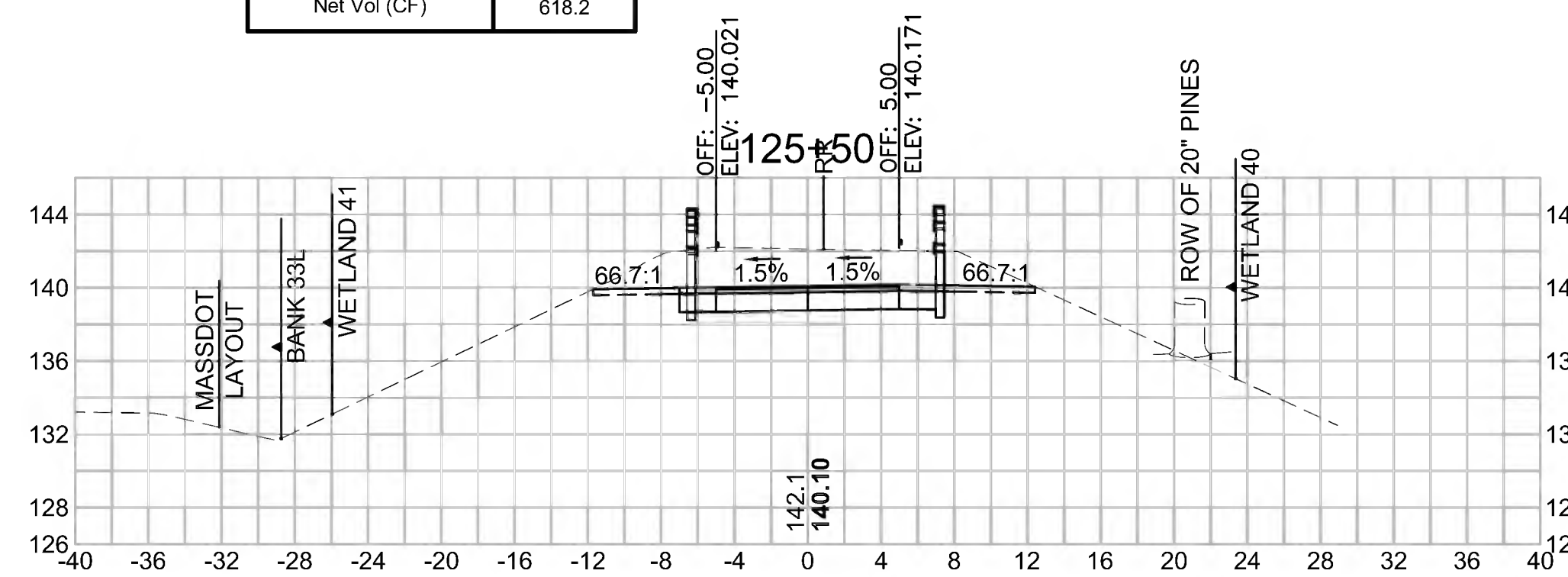

Total Volume at Station 127+00.00

Cut Area (SF)	27.206
Fill Area (SF)	0.000
Cut Vol (CF)	40.781
Fill Vol (CF)	2.9
Cum Cut Vol (CF)	2277.211
Cum Fill Vol (CF)	1442.5
Net Vol (CF)	834.7

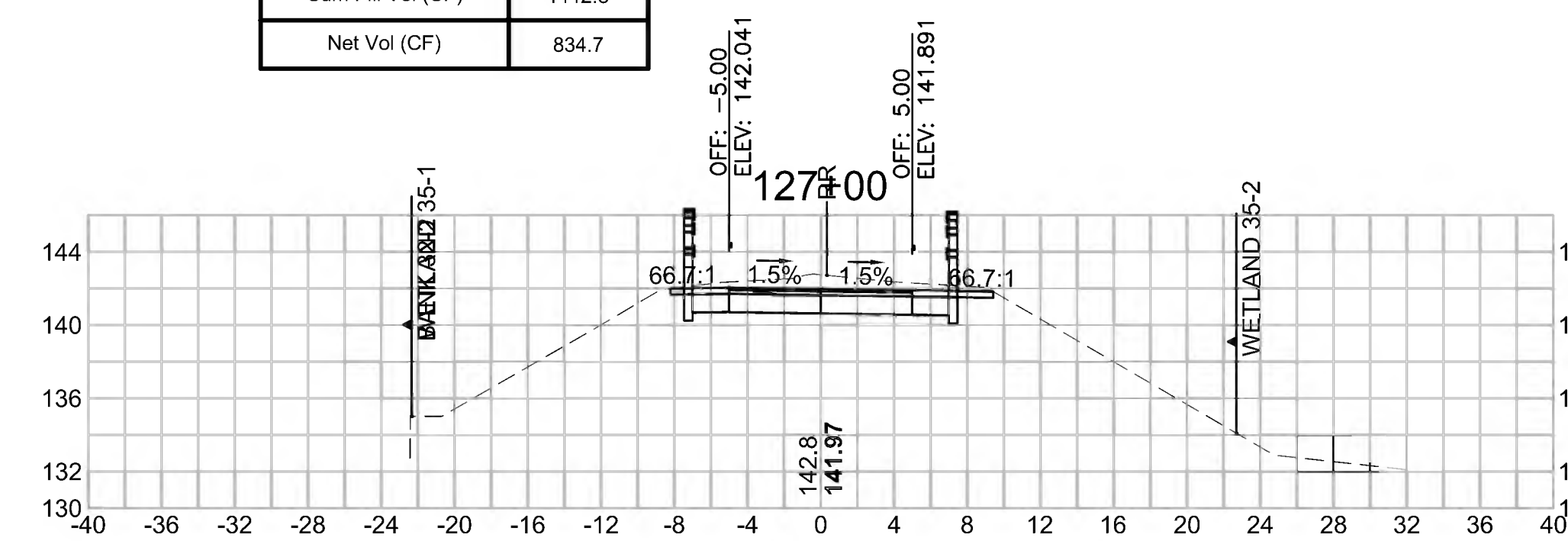

Total Volume at Station 123+50.00

Cut Area (SF)	34.537
Fill Area (SF)	0.000
Cut Vol (CF)	63.901
Fill Vol (CF)	0.0
Cum Cut Vol (CF)	1731.873
Cum Fill Vol (CF)	1436.6
Net Vol (CF)	295.3

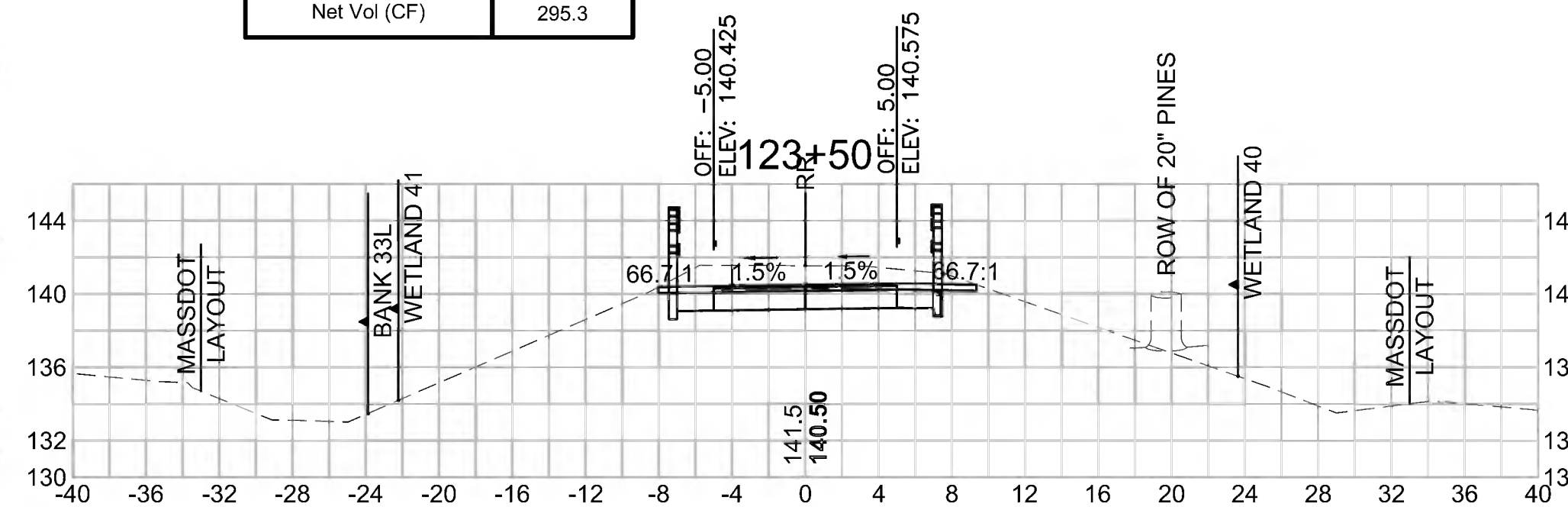

Total Volume at Station 125+00.00

Cut Area (SF)	52.560
Fill Area (SF)	0.000
Cut Vol (CF)	83.010
Fill Vol (CF)	0.0
Cum Cut Vol (CF)	1949.170
Cum Fill Vol (CF)	1436.6
Net Vol (CF)	512.5

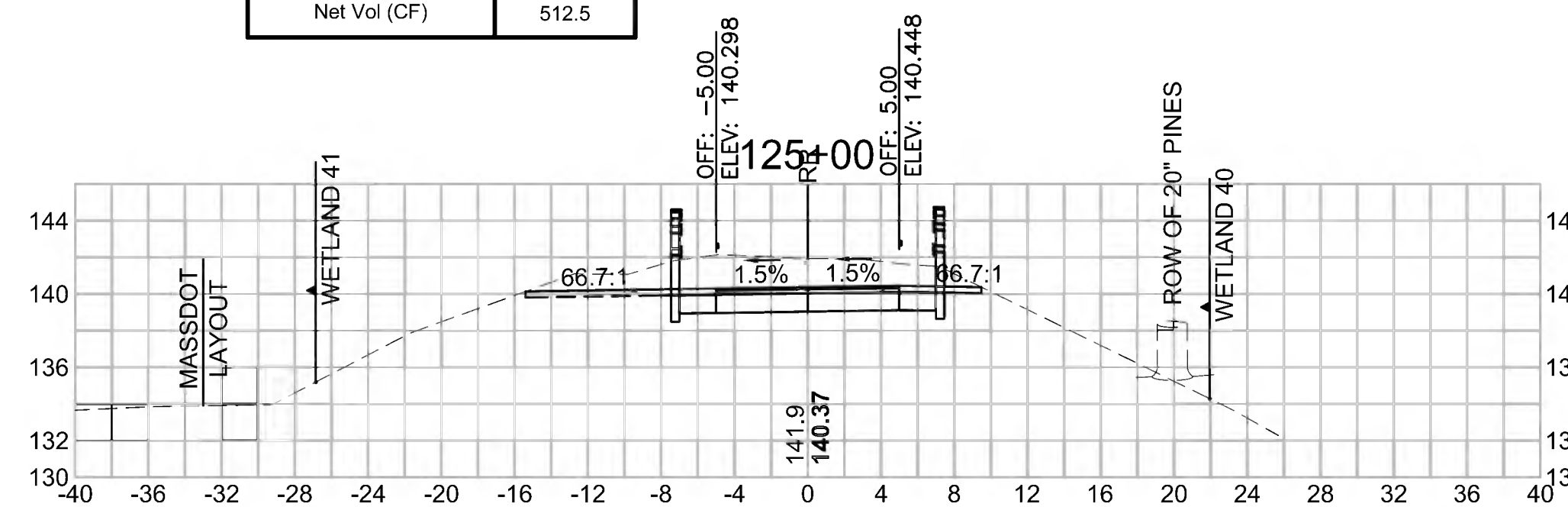

Total Volume at Station 126+50.00

Cut Area (SF)	16.837
Fill Area (SF)	3.166
Cut Vol (CF)	70.117
Fill Vol (CF)	2.9
Cum Cut Vol (CF)	2236.430
Cum Fill Vol (CF)	1439.6
Net Vol (CF)	796.9

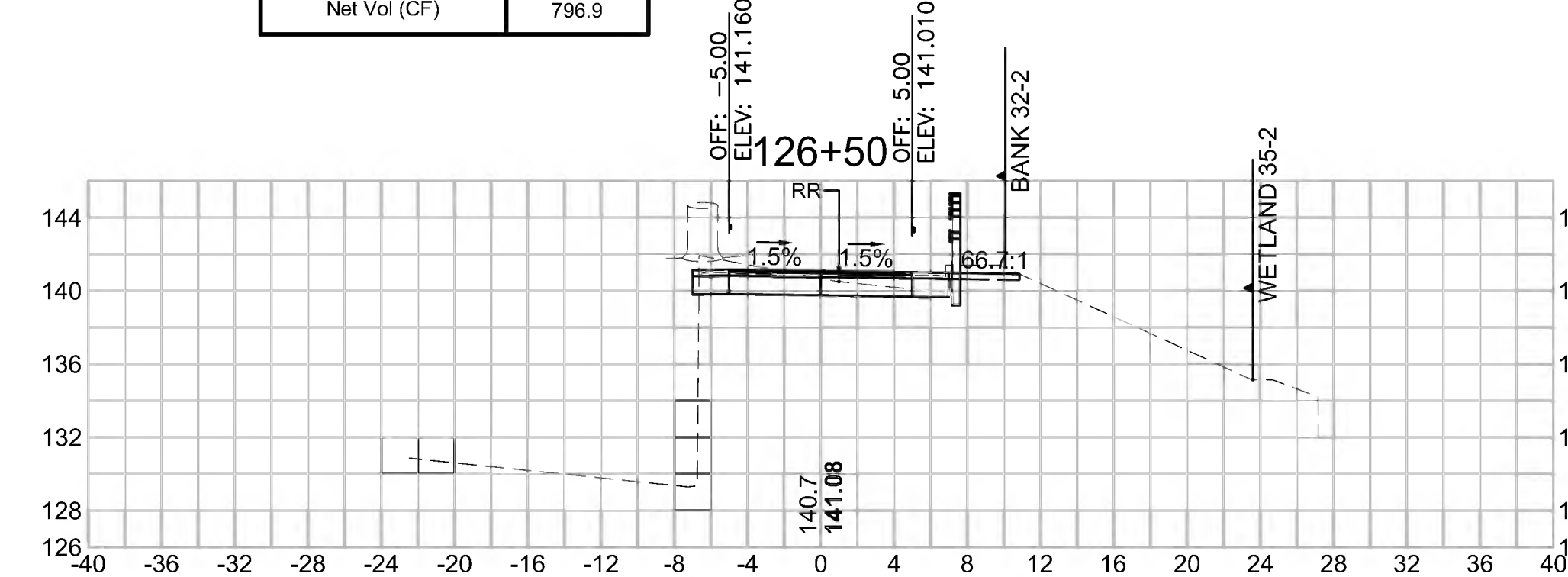

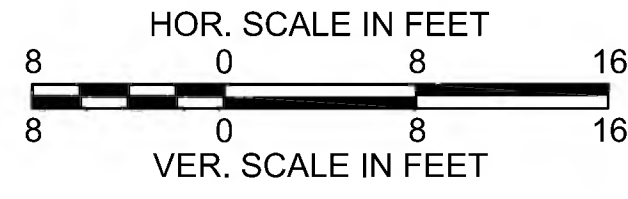

SUDBURY
 BRUCE FREEMAN RAIL TRAIL

STATE	FED. AID PROJ. NO.	SHEET NO.	TOTAL SHEETS
MA	XXX-XXX(XXX)X	251	319

PROJECT FILE NO. 608164

CROSS SECTIONS

Total Volume at Station 129+00.00

Cut Area (SF)	22.380
Fill Area (SF)	0.000
Cut Vol (CF)	42.336
Fill Vol (CF)	0.0
Cum Cut Vol (CF)	2451.904
Cum Fill Vol (CF)	1442.5
Net Vol (CF)	1009.4

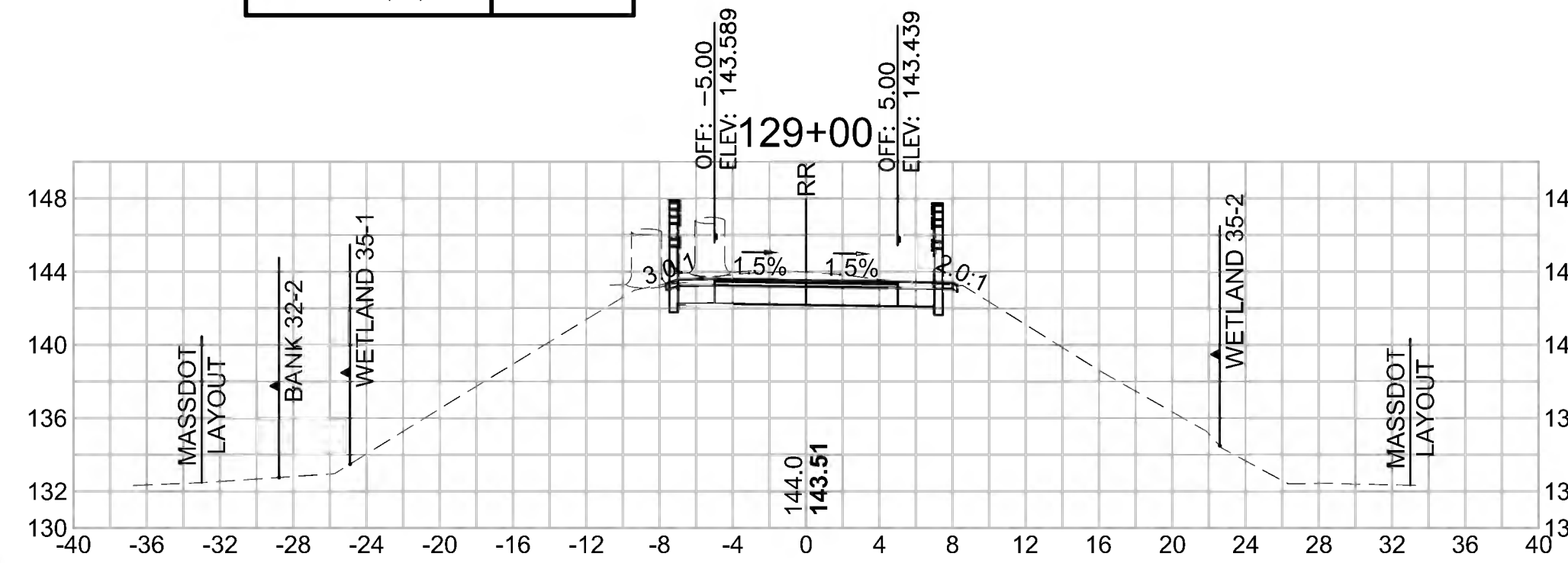

Total Volume at Station 130+50.00

Cut Area (SF)	24.796
Fill Area (SF)	0.000
Cut Vol (CF)	43.308
Fill Vol (CF)	0.3
Cum Cut Vol (CF)	2578.048
Cum Fill Vol (CF)	1443.1
Net Vol (CF)	1134.9

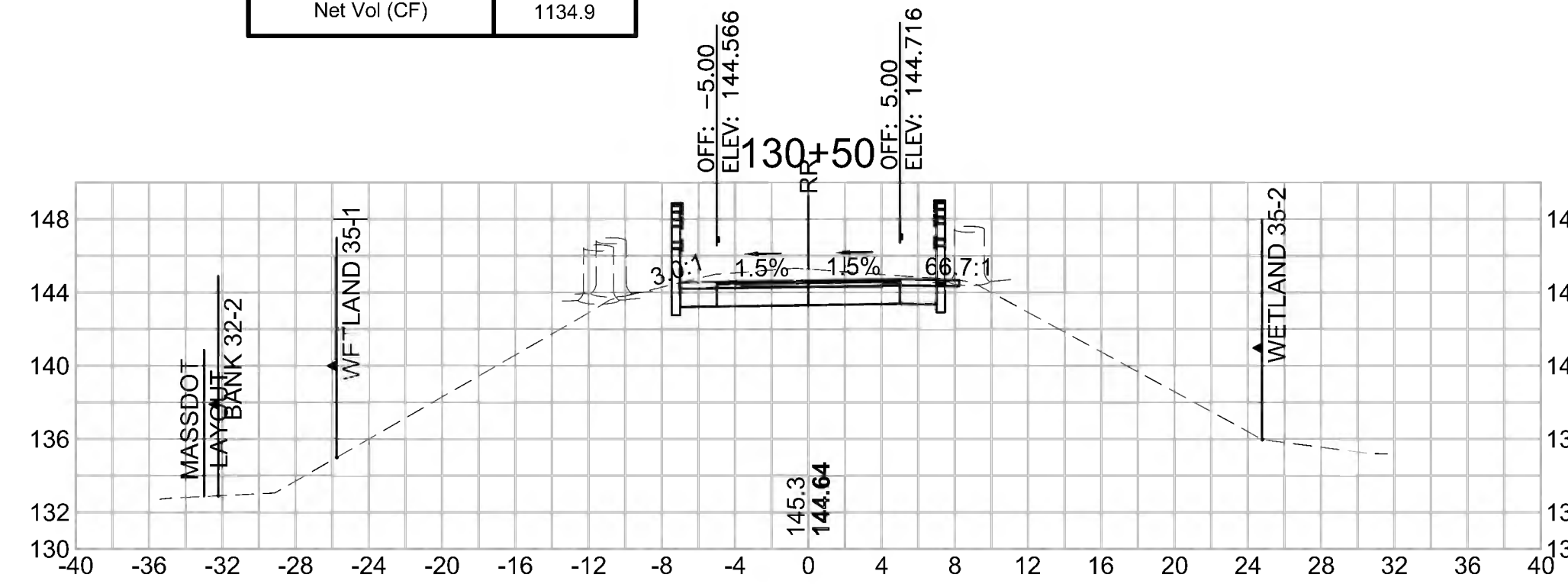

Total Volume at Station 132+00.00

Cut Area (SF)	23.474
Fill Area (SF)	0.000
Cut Vol (CF)	47.577
Fill Vol (CF)	0.0
Cum Cut Vol (CF)	2724.614
Cum Fill Vol (CF)	1443.1
Net Vol (CF)	1281.5

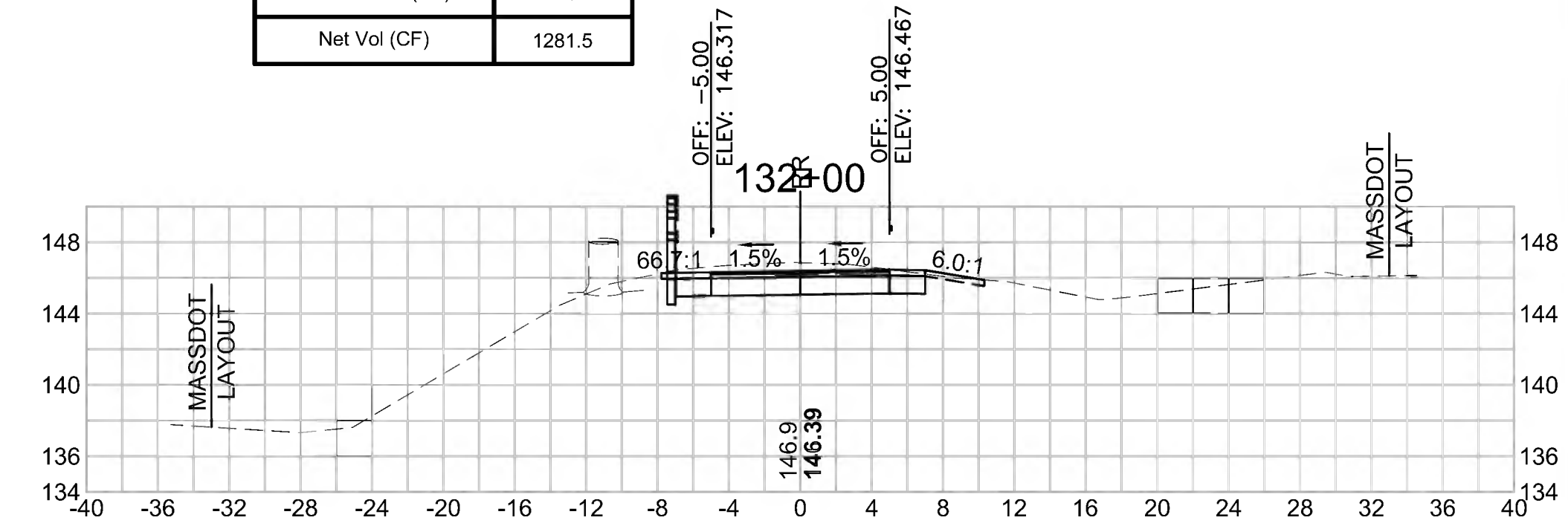

Total Volume at Station 128+50.00

Cut Area (SF)	23.343
Fill Area (SF)	0.000
Cut Vol (CF)	43.413
Fill Vol (CF)	0.0
Cum Cut Vol (CF)	2409.569
Cum Fill Vol (CF)	1442.5
Net Vol (CF)	967.1

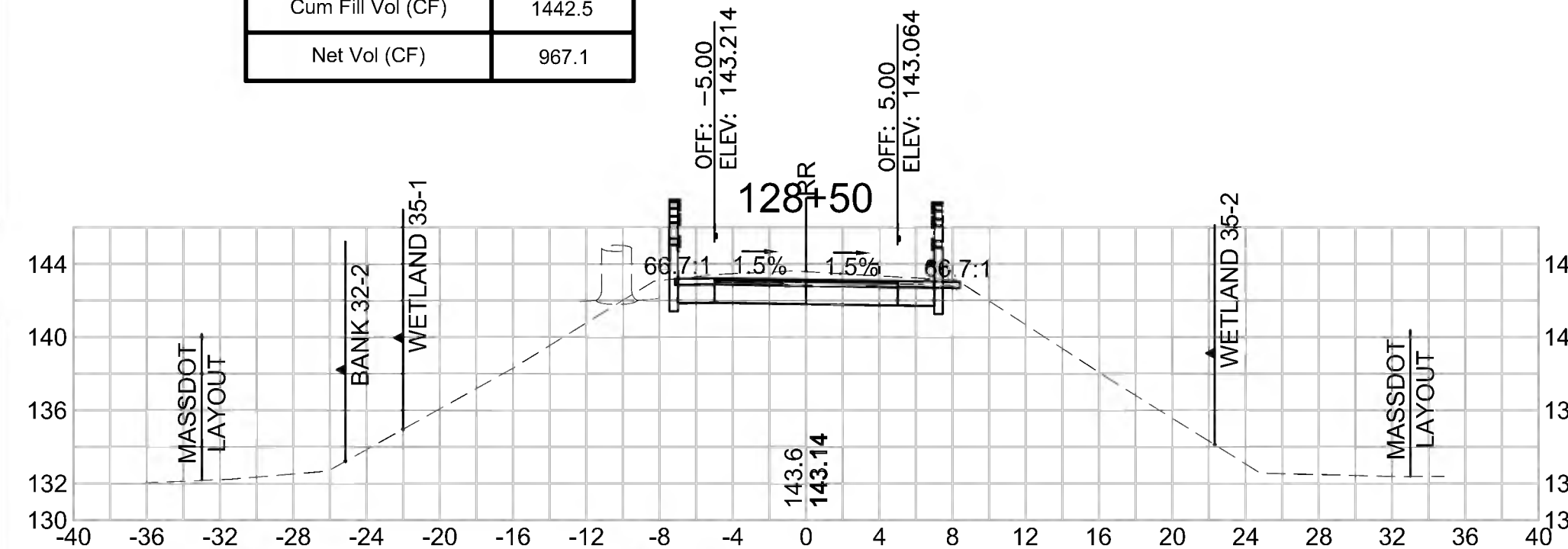

Total Volume at Station 130+00.00

Cut Area (SF)	21.976
Fill Area (SF)	0.307
Cut Vol (CF)	41.232
Fill Vol (CF)	0.3
Cum Cut Vol (CF)	2534.740
Cum Fill Vol (CF)	1442.9
Net Vol (CF)	1091.9

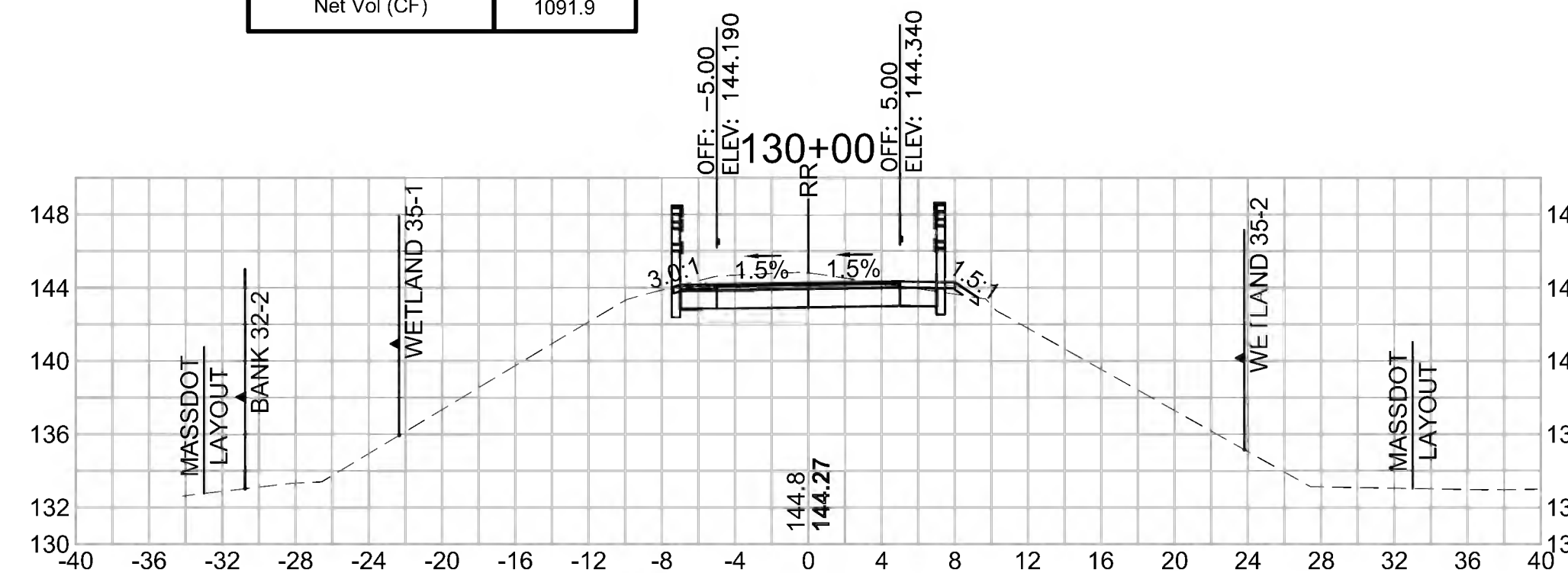

Total Volume at Station 131+50.00

Cut Area (SF)	27.909
Fill Area (SF)	0.000
Cut Vol (CF)	50.937
Fill Vol (CF)	0.0
Cum Cut Vol (CF)	2677.037
Cum Fill Vol (CF)	1443.1
Net Vol (CF)	1233.9

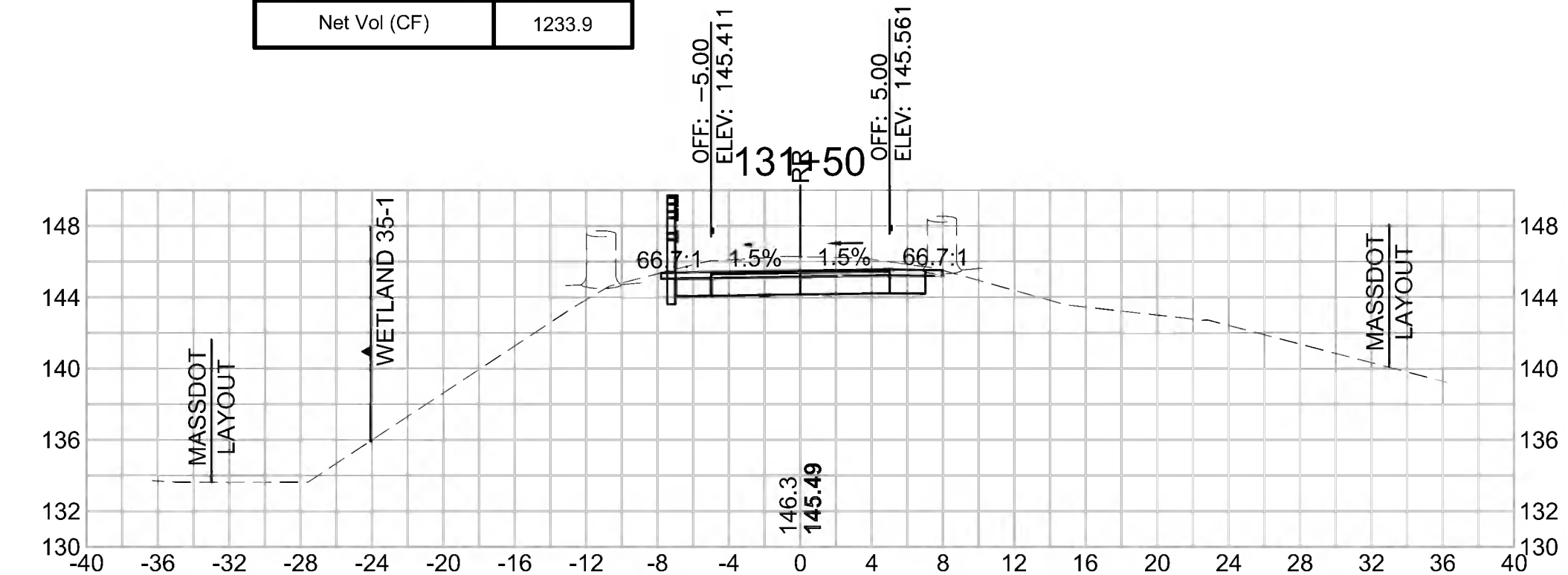

Total Volume at Station 128+00.00

Cut Area (SF)	23.543
Fill Area (SF)	0.000
Cut Vol (CF)	42.777
Fill Vol (CF)	0.0
Cum Cut Vol (CF)	2366.156
Cum Fill Vol (CF)	1442.5
Net Vol (CF)	923.7

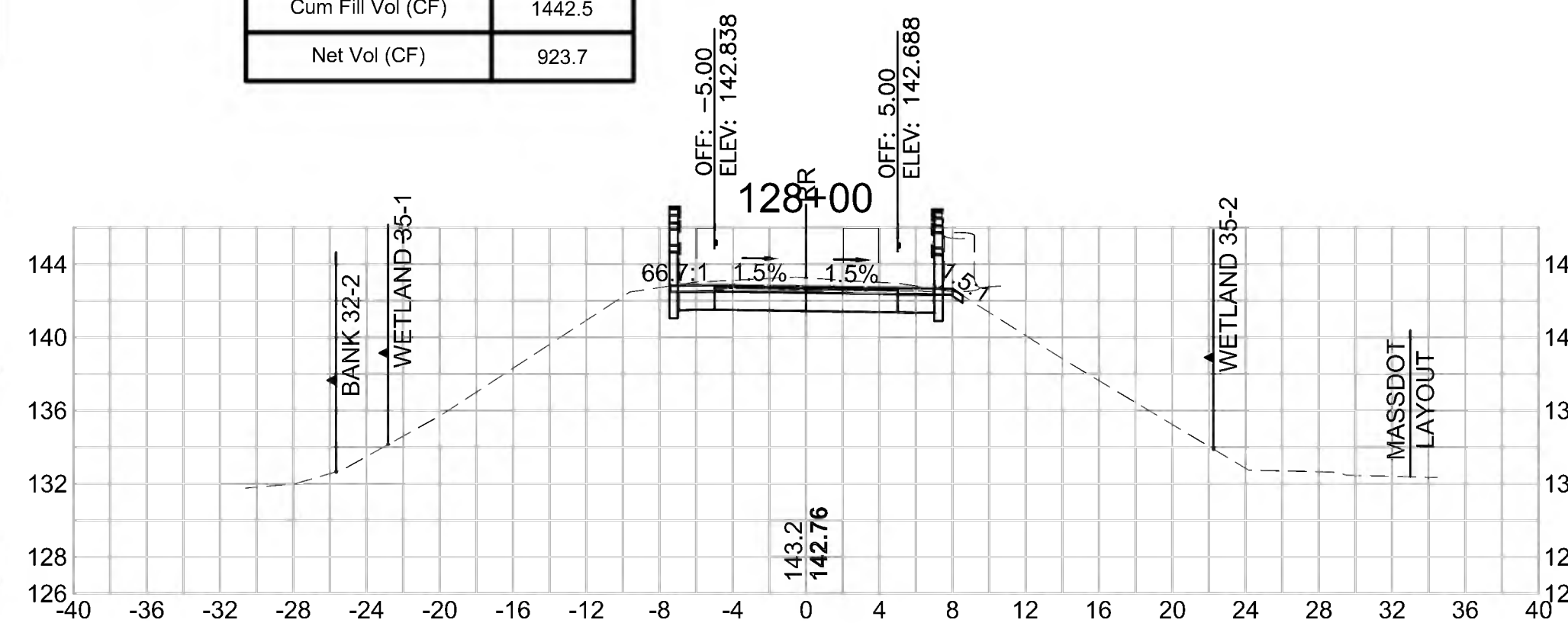

Total Volume at Station 129+50.00

Cut Area (SF)	22.554
Fill Area (SF)	0.046
Cut Vol (CF)	41.606
Fill Vol (CF)	0.0
Cum Cut Vol (CF)	2493.509
Cum Fill Vol (CF)	1442.5
Net Vol (CF)	1051.0

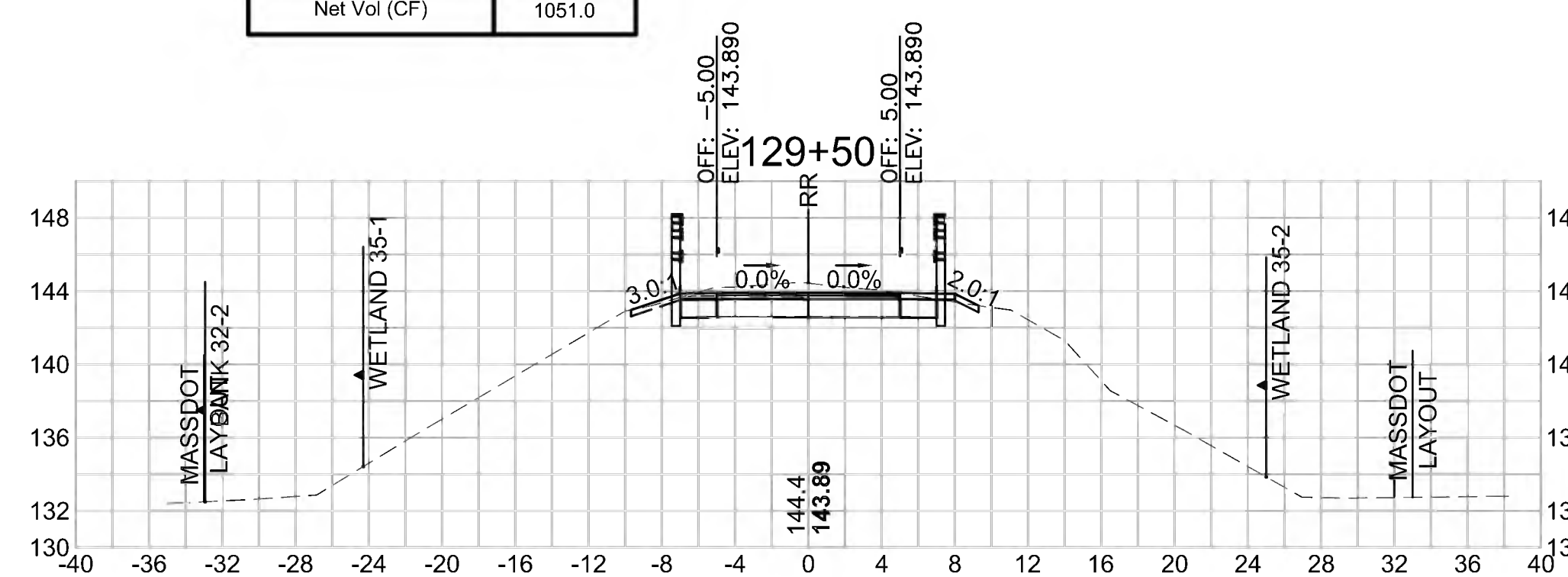

Total Volume at Station 131+00.00

Cut Area (SF)	27.102
Fill Area (SF)	0.000
Cut Vol (CF)	48.054
Fill Vol (CF)	0.0
Cum Cut Vol (CF)	2626.101
Cum Fill Vol (CF)	1443.1
Net Vol (CF)	1183.0

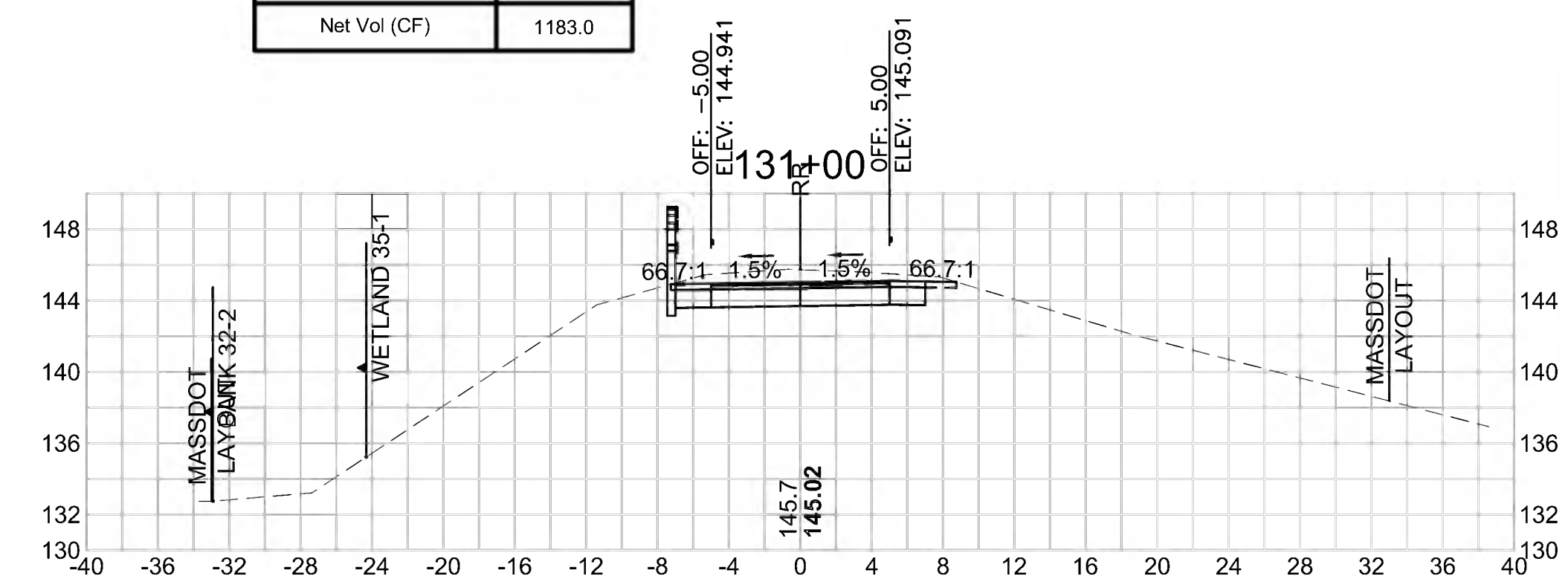

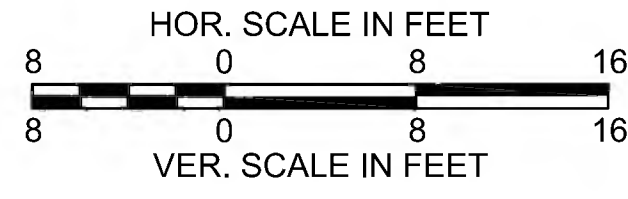

SUDBURY
 BRUCE FREEMAN RAIL TRAIL

STATE	FED. AID PROJ. NO.	SHEET NO.	TOTAL SHEETS
MA	XXX-XXX(XXX)X	252	319

PROJECT FILE NO. 608164

CROSS SECTIONS

Total Volume at Station 133+50.00

Cut Area (SF)	2.104
Fill Area (SF)	5.934
Cut Vol (CF)	10.399
Fill Vol (CF)	6.9
Cum Cut Vol (CF)	2795.223
Cum Fill Vol (CF)	1451.8
Net Vol (CF)	1343.4

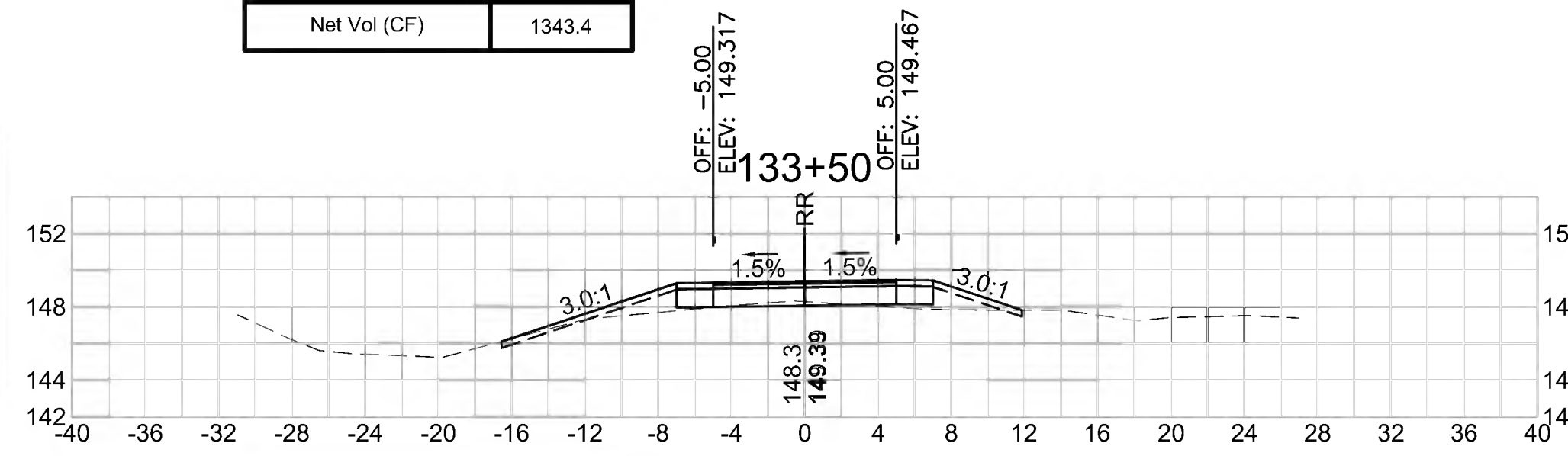

Total Volume at Station 135+00.00

Cut Area (SF)	3.376
Fill Area (SF)	1.345
Cut Vol (CF)	4.433
Fill Vol (CF)	4.9
Cum Cut Vol (CF)	2803.574
Cum Fill Vol (CF)	1490.2
Net Vol (CF)	1313.3

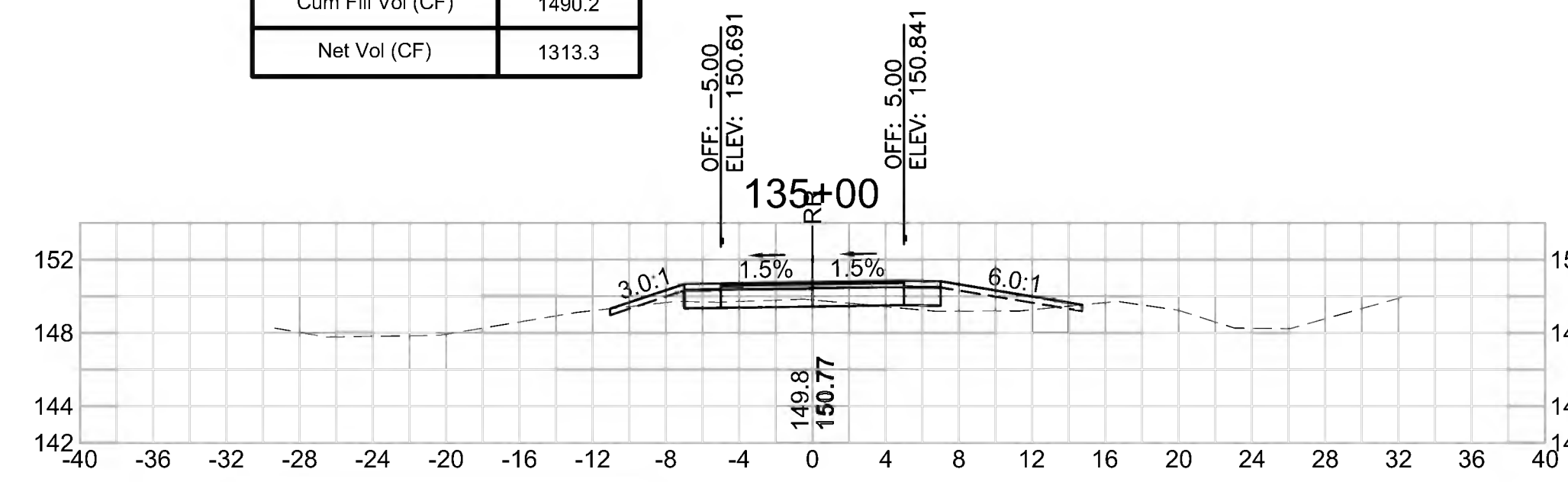

Total Volume at Station 136+50.00

Cut Area (SF)	13.783
Fill Area (SF)	1.120
Cut Vol (CF)	21.161
Fill Vol (CF)	2.3
Cum Cut Vol (CF)	2850.628
Cum Fill Vol (CF)	1496.3
Net Vol (CF)	1354.3

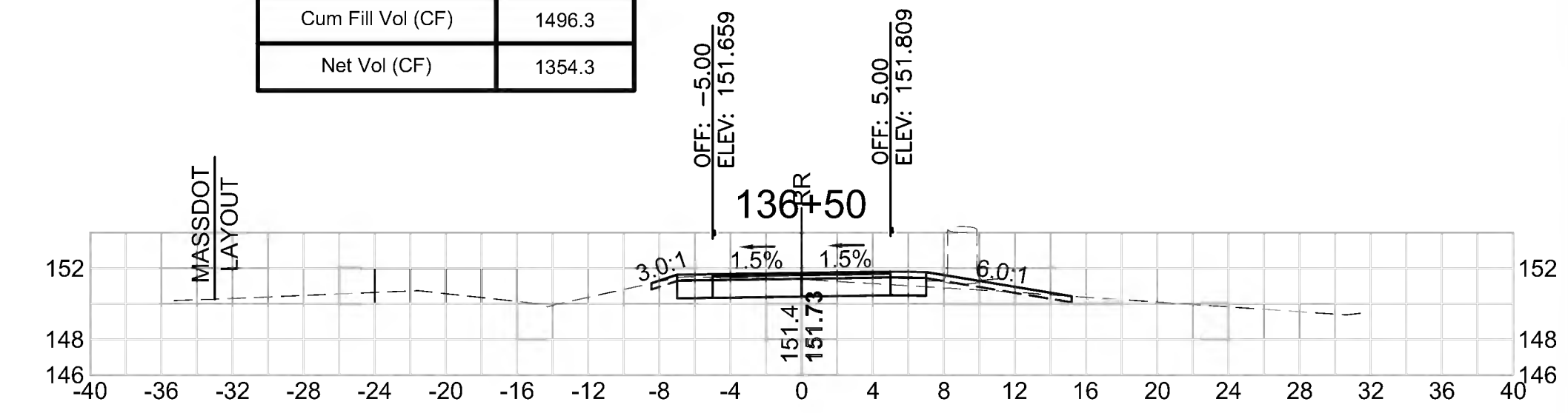

Total Volume at Station 133+00.00

Cut Area (SF)	9.126
Fill Area (SF)	1.521
Cut Vol (CF)	23.463
Fill Vol (CF)	1.6
Cum Cut Vol (CF)	2784.824
Cum Fill Vol (CF)	1444.9
Net Vol (CF)	1339.9

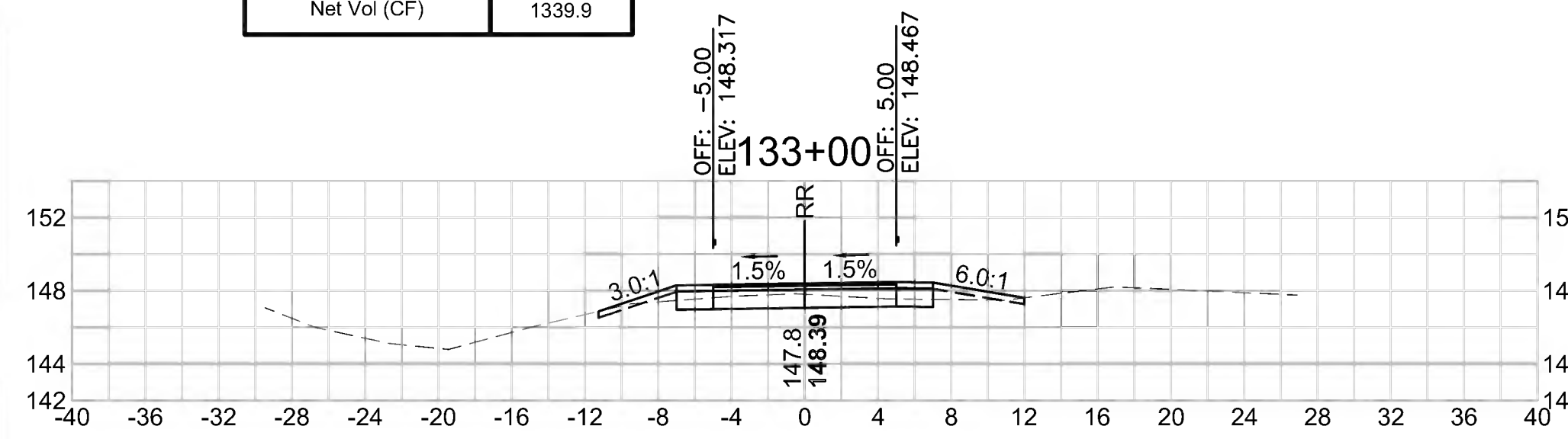

Total Volume at Station 134+50.00

Cut Area (SF)	1.412
Fill Area (SF)	3.898
Cut Vol (CF)	1.639
Fill Vol (CF)	15.8
Cum Cut Vol (CF)	2799.141
Cum Fill Vol (CF)	1485.4
Net Vol (CF)	1313.7

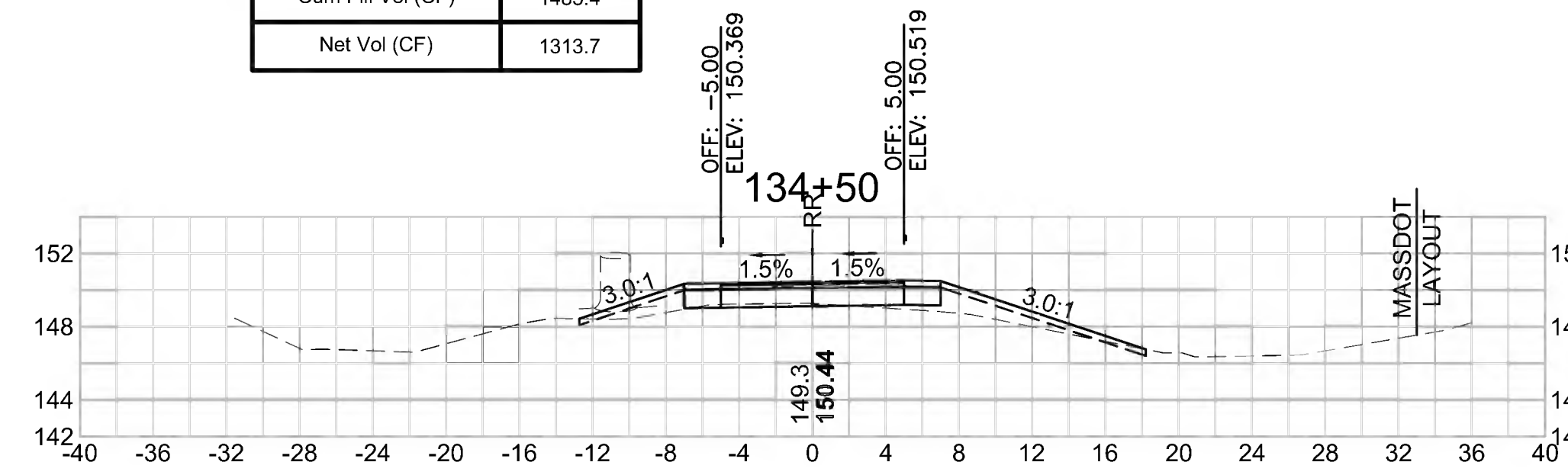

Total Volume at Station 136+00.00

Cut Area (SF)	9.071
Fill Area (SF)	1.398
Cut Vol (CF)	15.584
Fill Vol (CF)	1.9
Cum Cut Vol (CF)	2829.467
Cum Fill Vol (CF)	1494.0
Net Vol (CF)	1335.5

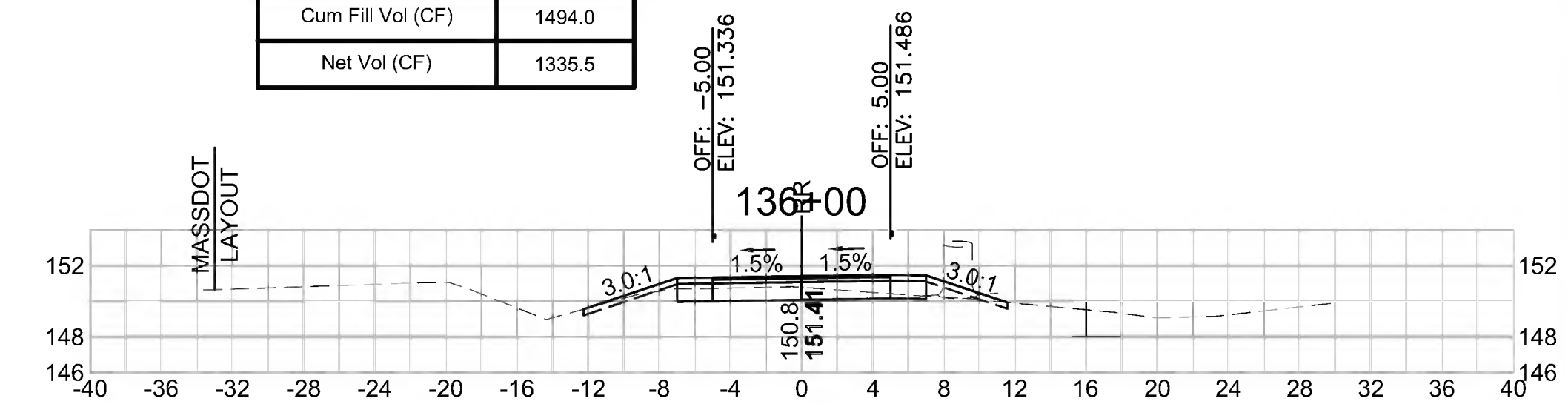

Total Volume at Station 132+50.00

Cut Area (SF)	16.213
Fill Area (SF)	0.195
Cut Vol (CF)	36.748
Fill Vol (CF)	0.2
Cum Cut Vol (CF)	2761.361
Cum Fill Vol (CF)	1443.3
Net Vol (CF)	1318.0

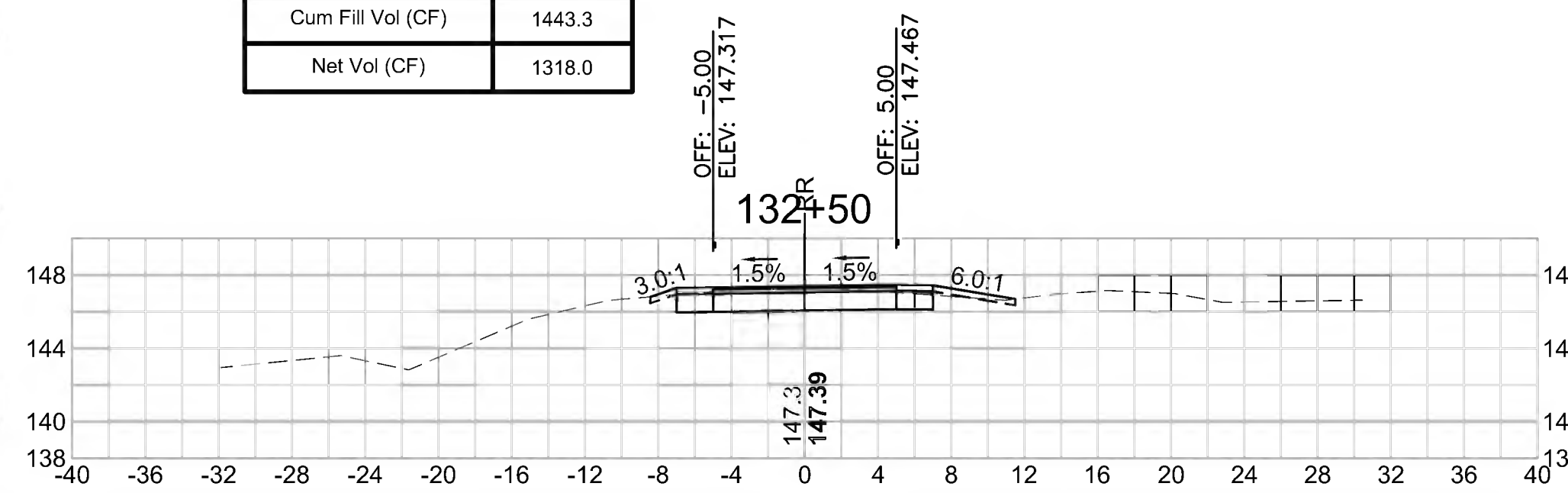

Total Volume at Station 134+00.00

Cut Area (SF)	0.358
Fill Area (SF)	13.218
Cut Vol (CF)	2.281
Fill Vol (CF)	17.7
Cum Cut Vol (CF)	2797.503
Cum Fill Vol (CF)	1469.5
Net Vol (CF)	1328.0

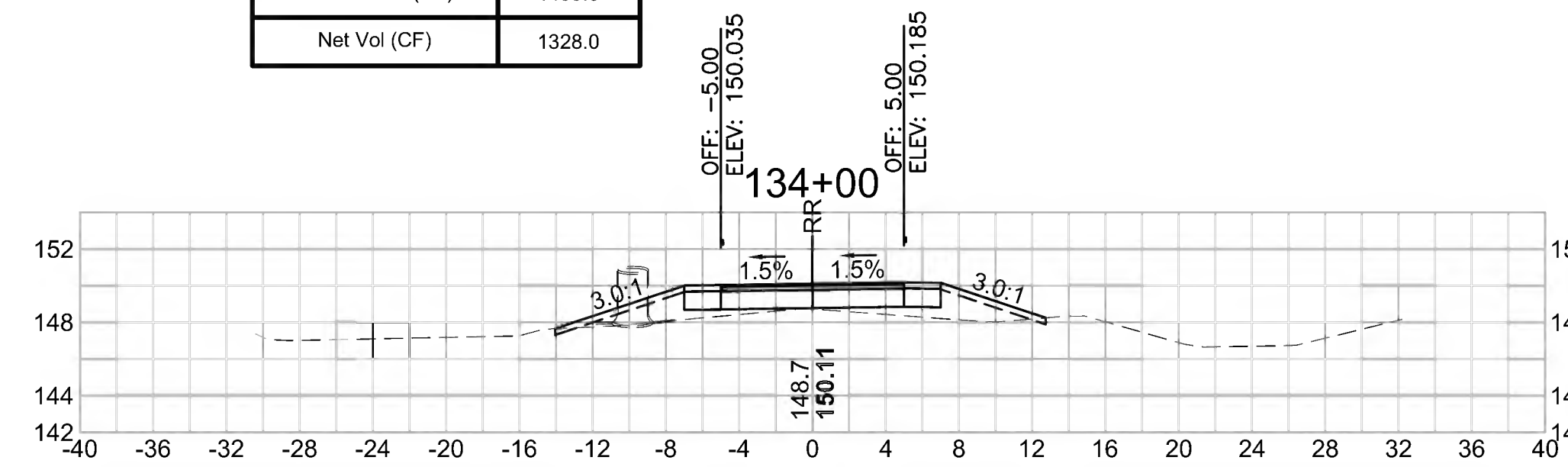

Total Volume at Station 135+50.00

Cut Area (SF)	7.759
Fill Area (SF)	0.630
Cut Vol (CF)	10.311
Fill Vol (CF)	1.8
Cum Cut Vol (CF)	2813.884
Cum Fill Vol (CF)	1492.1
Net Vol (CF)	1321.8

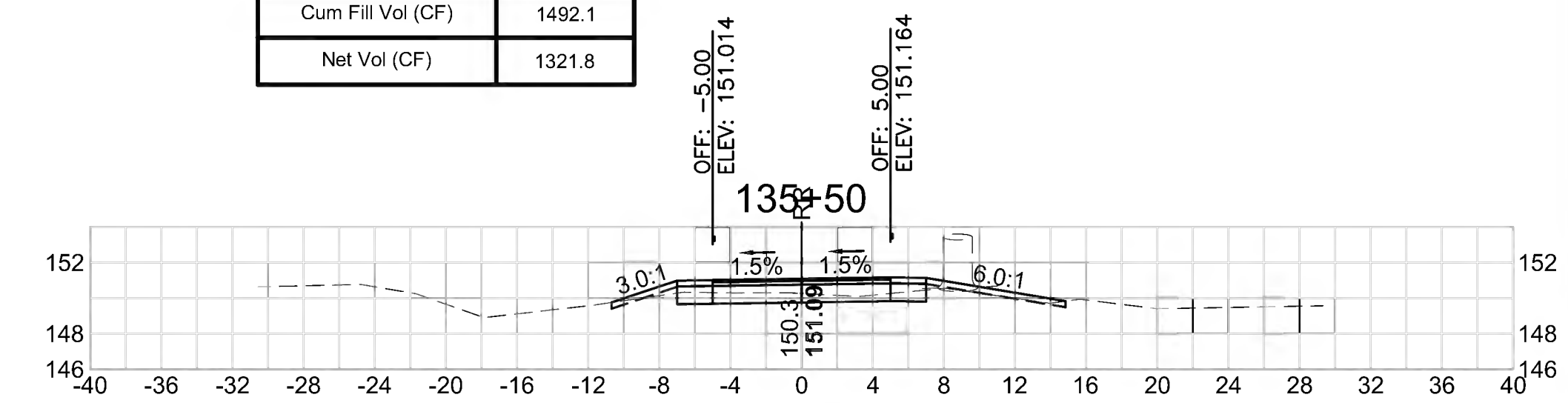

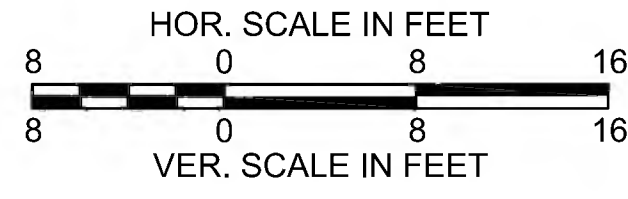

SUDBURY
 BRUCE FREEMAN RAIL TRAIL

STATE	FED. AID PROJ. NO.	SHEET NO.	TOTAL SHEETS
MA	XXX-XXXX(XXX)X	253	319

PROJECT FILE NO. 608164

CROSS SECTIONS

608164_XSEC(CROSS SECTION LAYOUTS).DWG 18-Feb-2022

Total Volume at Station 138+00.00

Cut Area (SF)	22.037
Fill Area (SF)	0.000
Cut Vol (CF)	39.805
Fill Vol (CF)	0.0
Cum Cut Vol (CF)	2956.172
Cum Fill Vol (CF)	1498.0
Net Vol (CF)	1458.2

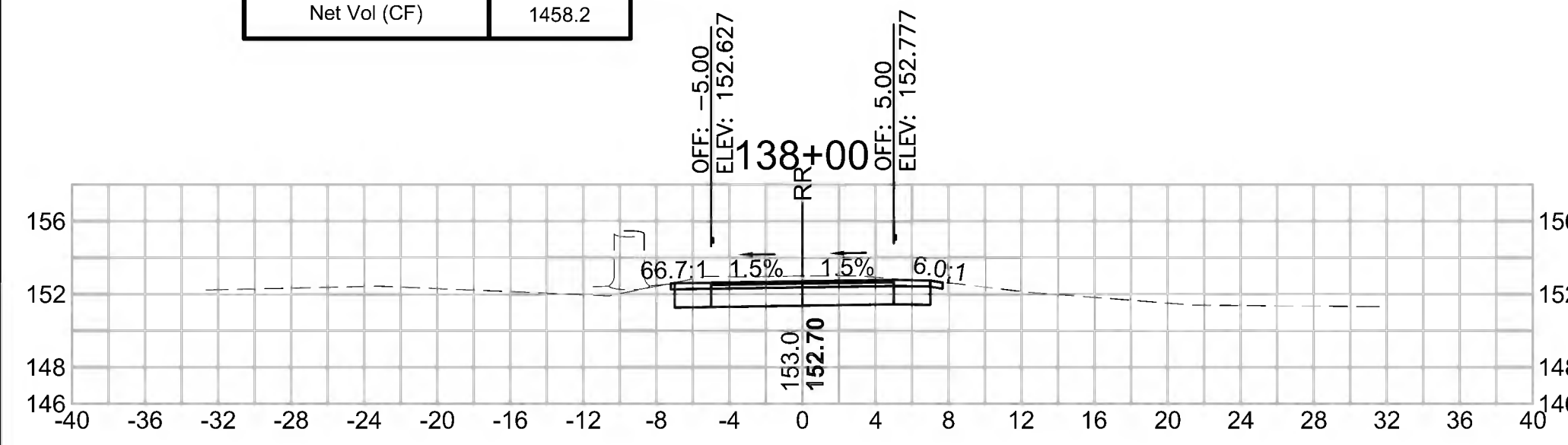

Total Volume at Station 139+50.00

Cut Area (SF)	20.464
Fill Area (SF)	0.000
Cut Vol (CF)	43.359
Fill Vol (CF)	0.0
Cum Cut Vol (CF)	3089.860
Cum Fill Vol (CF)	1498.0
Net Vol (CF)	1591.9

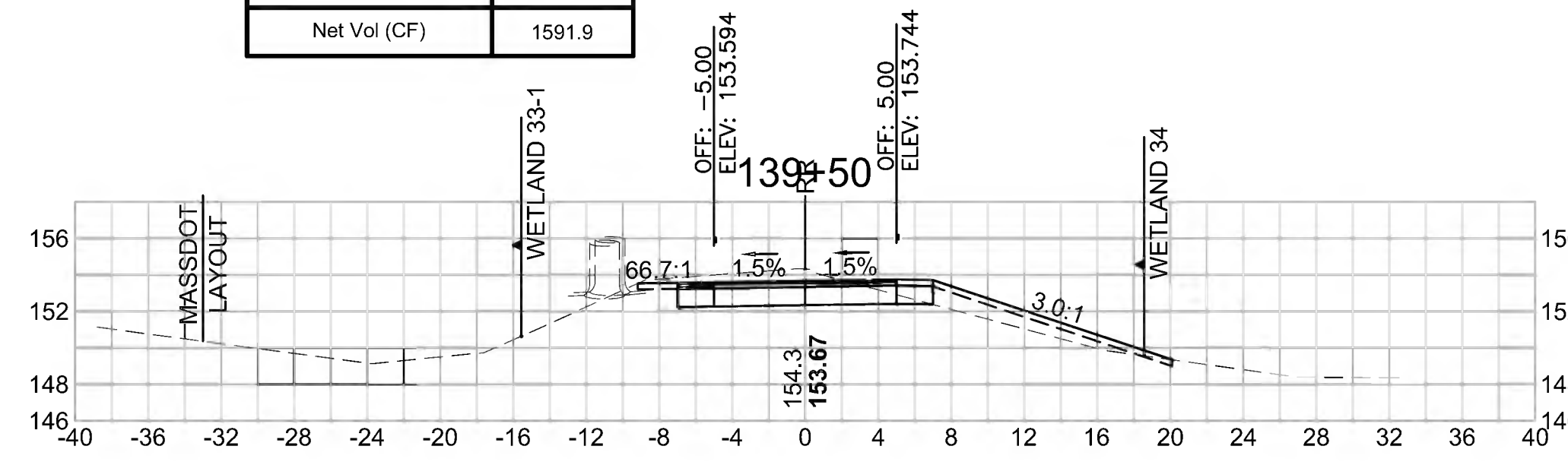

Total Volume at Station 141+00.00

Cut Area (SF)	29.263
Fill Area (SF)	0.000
Cut Vol (CF)	58.810
Fill Vol (CF)	0.0
Cum Cut Vol (CF)	3252.955
Cum Fill Vol (CF)	1498.0
Net Vol (CF)	1755.0

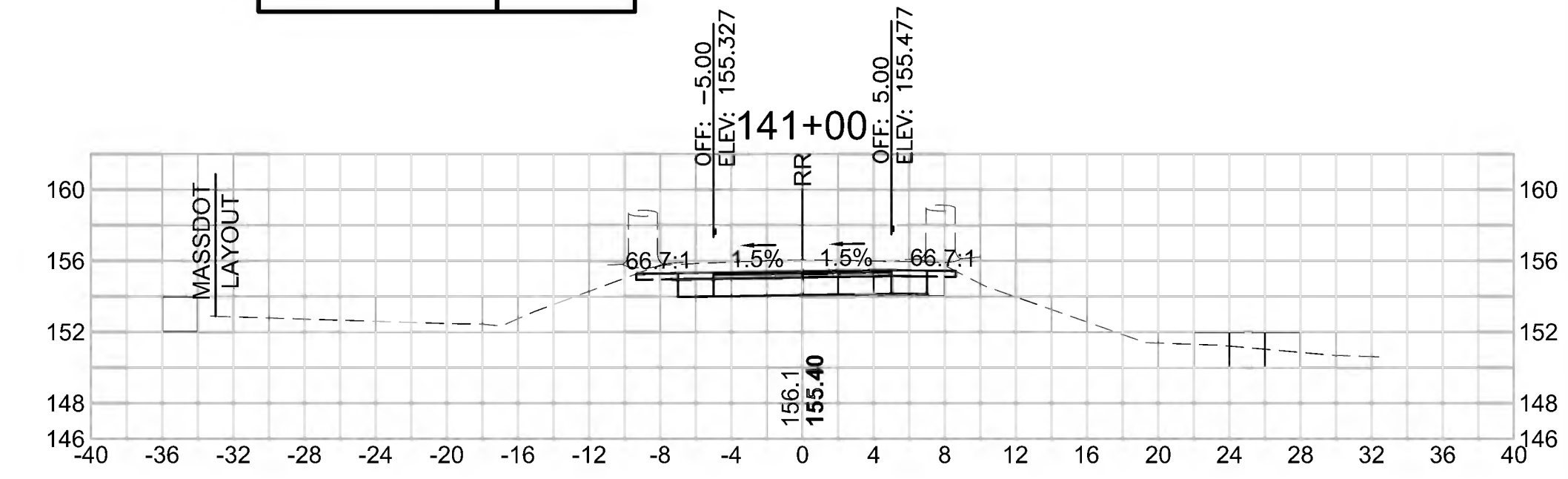

Total Volume at Station 137+50.00

Cut Area (SF)	20.952
Fill Area (SF)	0.033
Cut Vol (CF)	36.189
Fill Vol (CF)	0.3
Cum Cut Vol (CF)	2916.368
Cum Fill Vol (CF)	1497.9
Net Vol (CF)	1418.4

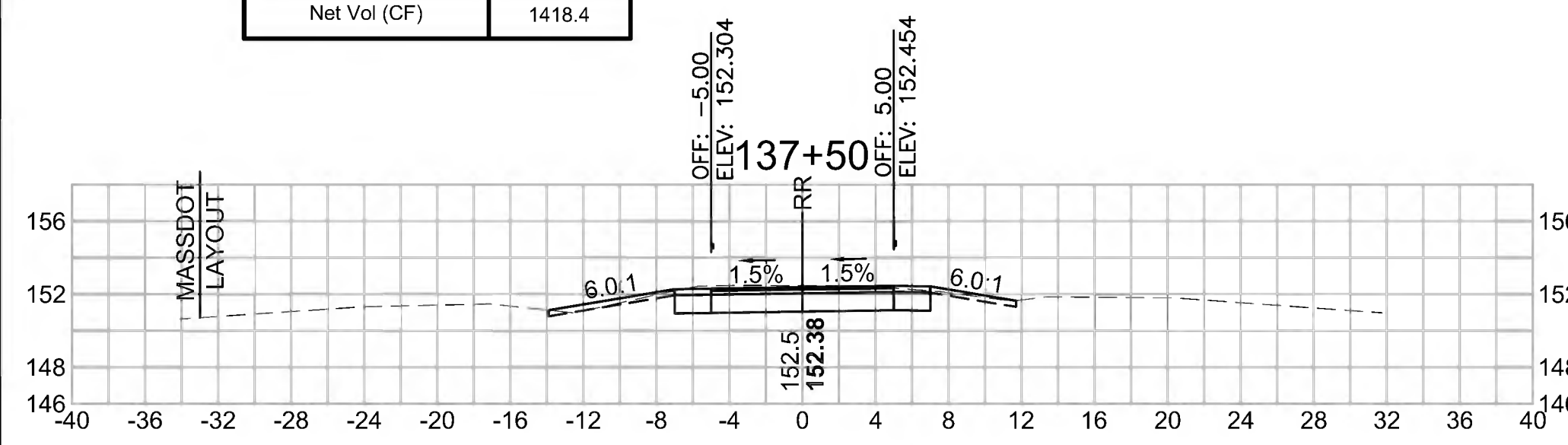

Total Volume at Station 139+00.00

Cut Area (SF)	26.364
Fill Area (SF)	0.000
Cut Vol (CF)	47.168
Fill Vol (CF)	0.0
Cum Cut Vol (CF)	3046.501
Cum Fill Vol (CF)	1498.0
Net Vol (CF)	1548.5

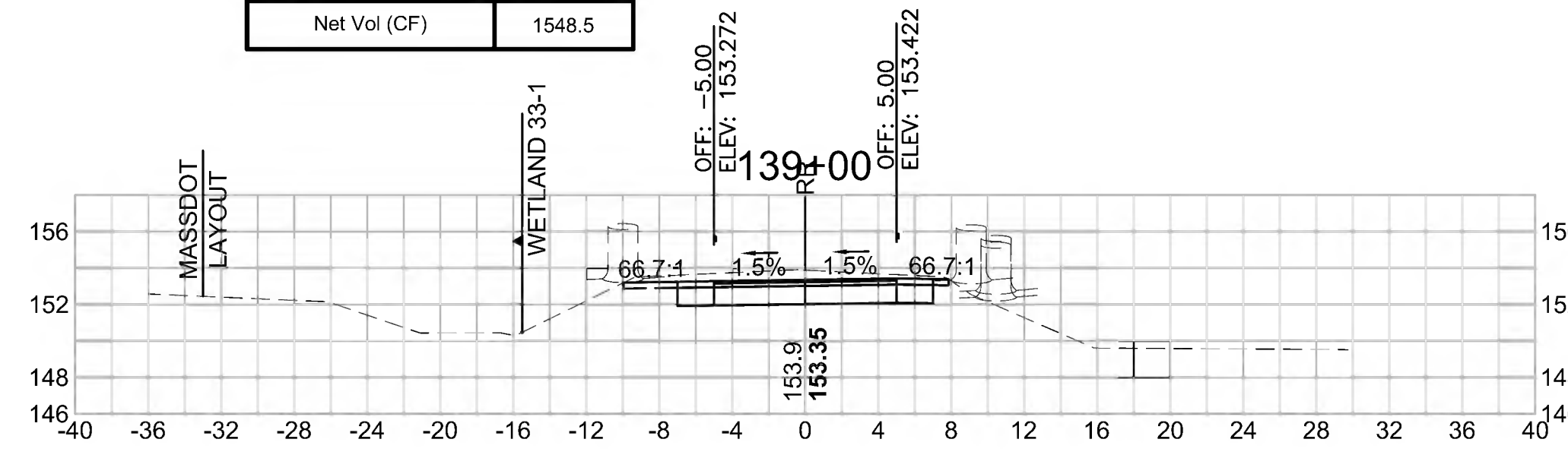

Total Volume at Station 140+50.00

Cut Area (SF)	34.252
Fill Area (SF)	0.000
Cut Vol (CF)	58.527
Fill Vol (CF)	0.0
Cum Cut Vol (CF)	3194.145
Cum Fill Vol (CF)	1498.0
Net Vol (CF)	1696.2

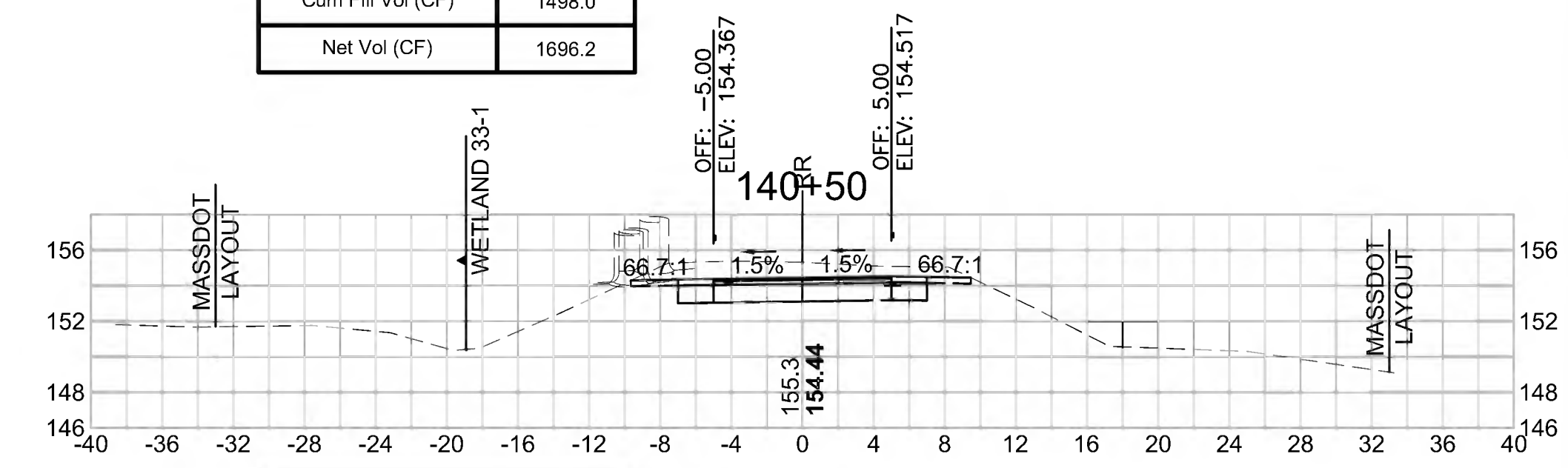

Total Volume at Station 137+00.00

Cut Area (SF)	18.132
Fill Area (SF)	0.314
Cut Vol (CF)	29.552
Fill Vol (CF)	1.3
Cum Cut Vol (CF)	2880.179
Cum Fill Vol (CF)	1497.6
Net Vol (CF)	1382.6

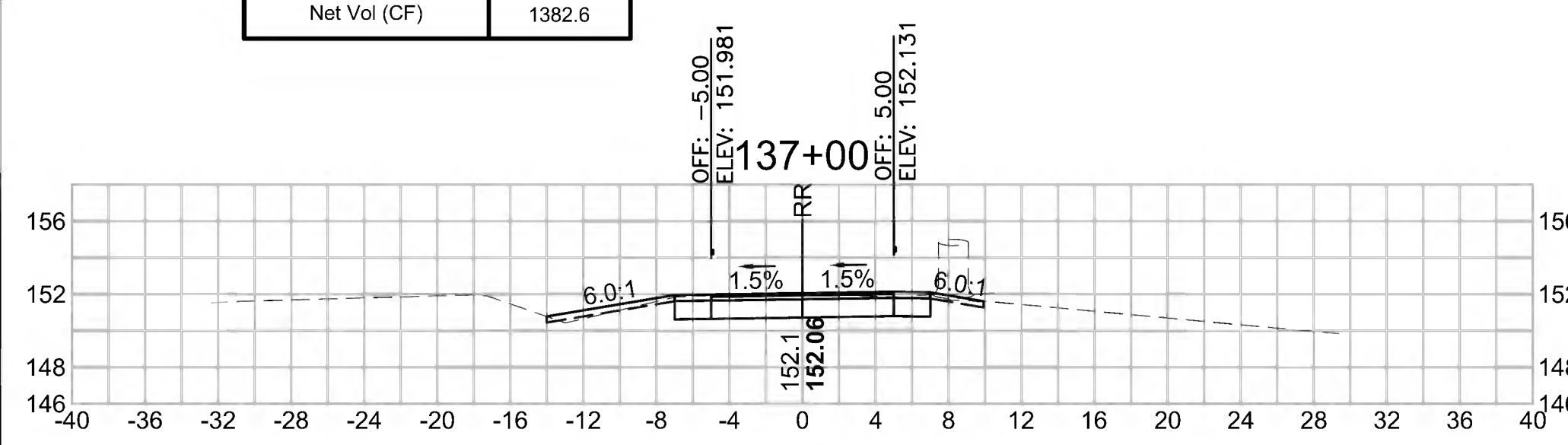

Total Volume at Station 138+50.00

Cut Area (SF)	24.577
Fill Area (SF)	0.000
Cut Vol (CF)	43.162
Fill Vol (CF)	0.0
Cum Cut Vol (CF)	2999.334
Cum Fill Vol (CF)	1498.0
Net Vol (CF)	1501.4

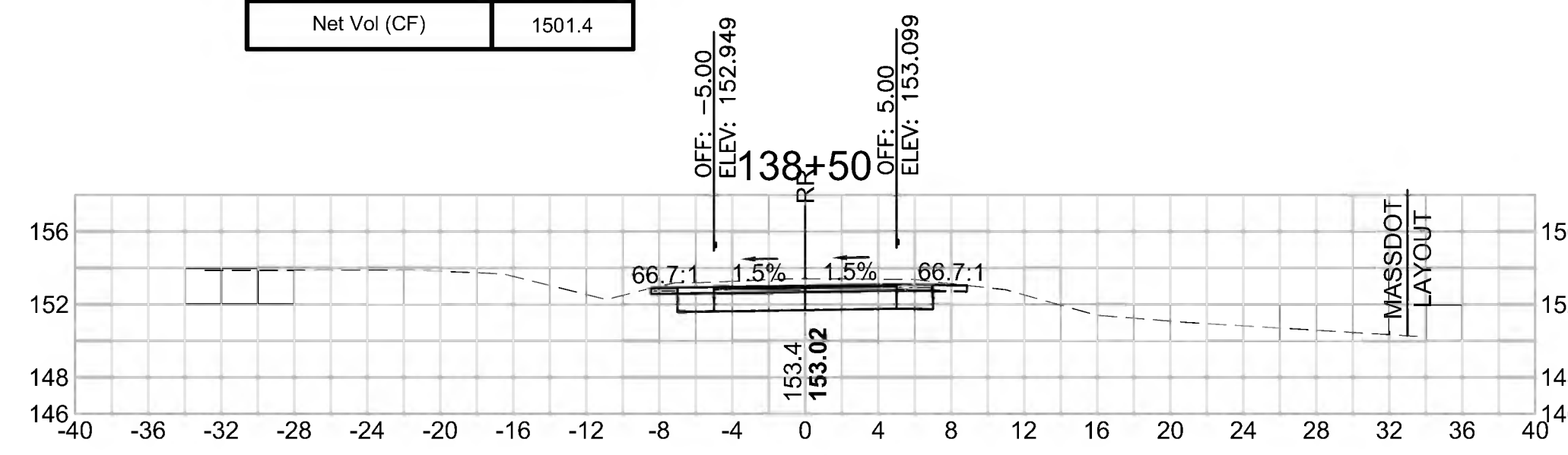

Total Volume at Station 140+00.00

Cut Area (SF)	28.956
Fill Area (SF)	0.000
Cut Vol (CF)	45.760
Fill Vol (CF)	0.0
Cum Cut Vol (CF)	3135.619
Cum Fill Vol (CF)	1498.0
Net Vol (CF)	1637.7

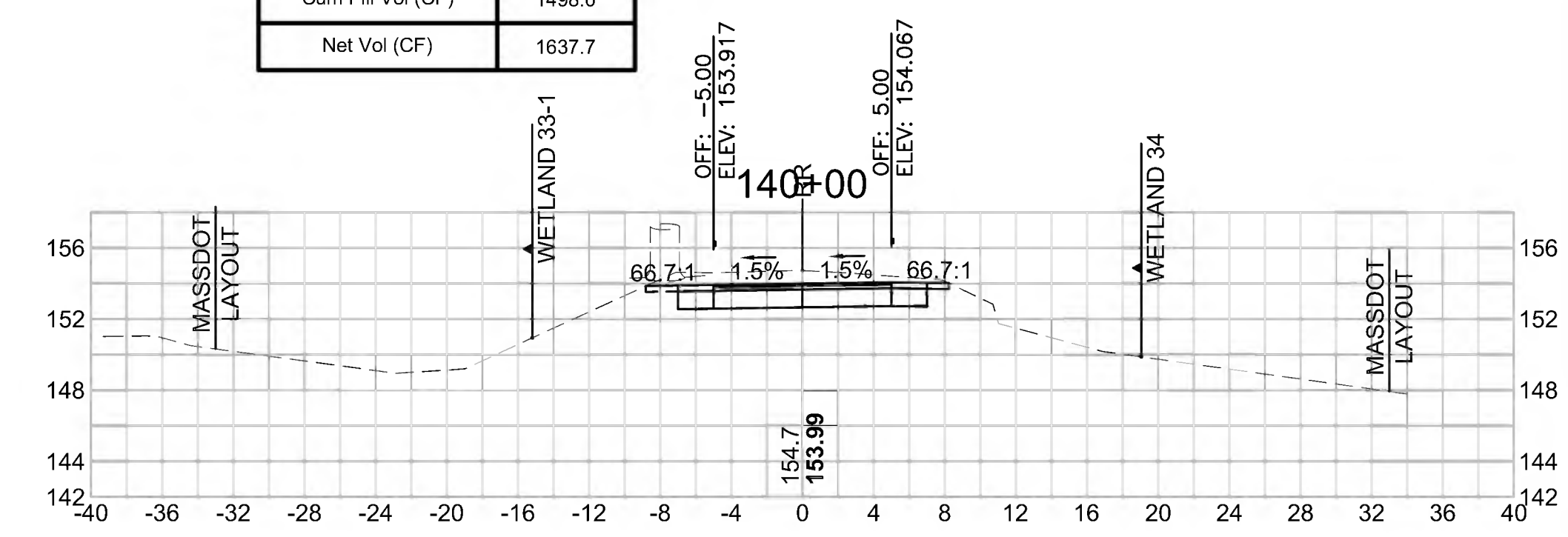

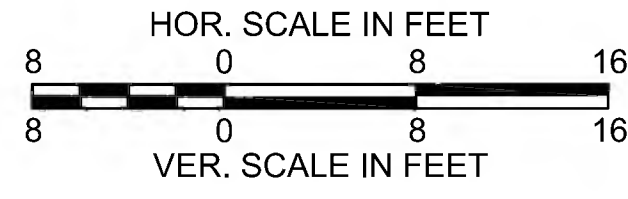

SUDBURY
 BRUCE FREEMAN RAIL TRAIL

STATE	FED. AID PROJ. NO.	SHEET NO.	TOTAL SHEETS
MA	XXX-XXXX(XXX)X	254	319

PROJECT FILE NO. 608164

CROSS SECTIONS

608164_XSEC(CROSS SECTION LAYOUTS).DWG 18-Feb-2022

Total Volume at Station 142+50.00

Cut Area (SF)	10.105
Fill Area (SF)	1.261
Cut Vol (CF)	22.725
Fill Vol (CF)	2.3
Cum Cut Vol (CF)	3348.100
Cum Fill Vol (CF)	1503.0
Net Vol (CF)	1845.1

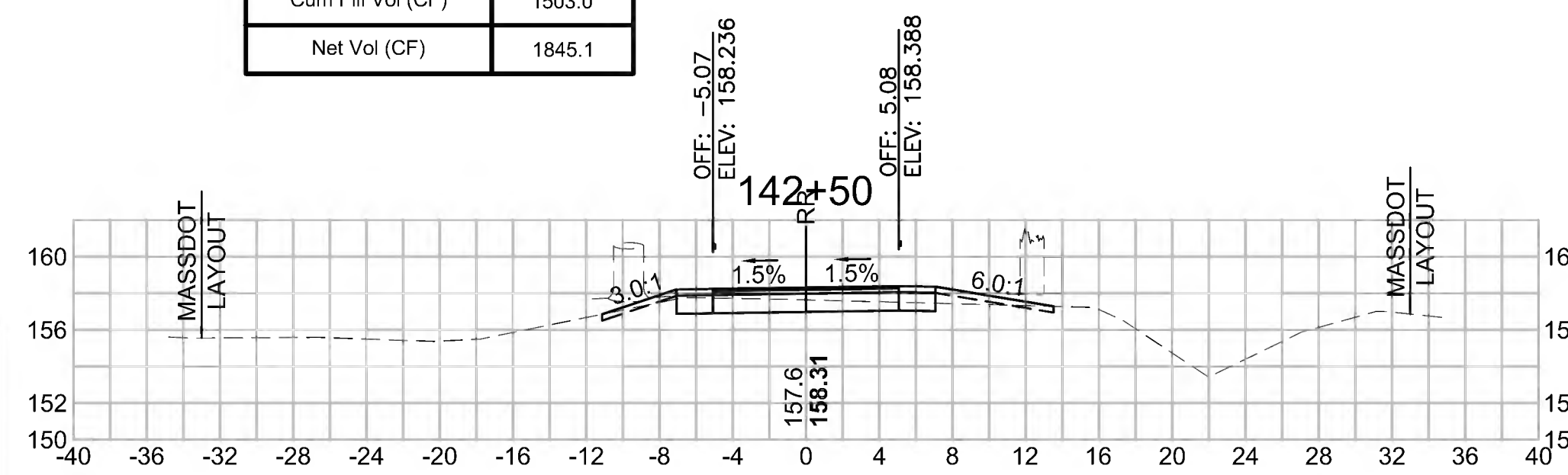

Total Volume at Station 144+00.00

Cut Area (SF)	3.029
Fill Area (SF)	6.893
Cut Vol (CF)	6.559
Fill Vol (CF)	12.5
Cum Cut Vol (CF)	3414.913
Cum Fill Vol (CF)	1522.9
Net Vol (CF)	1892.0

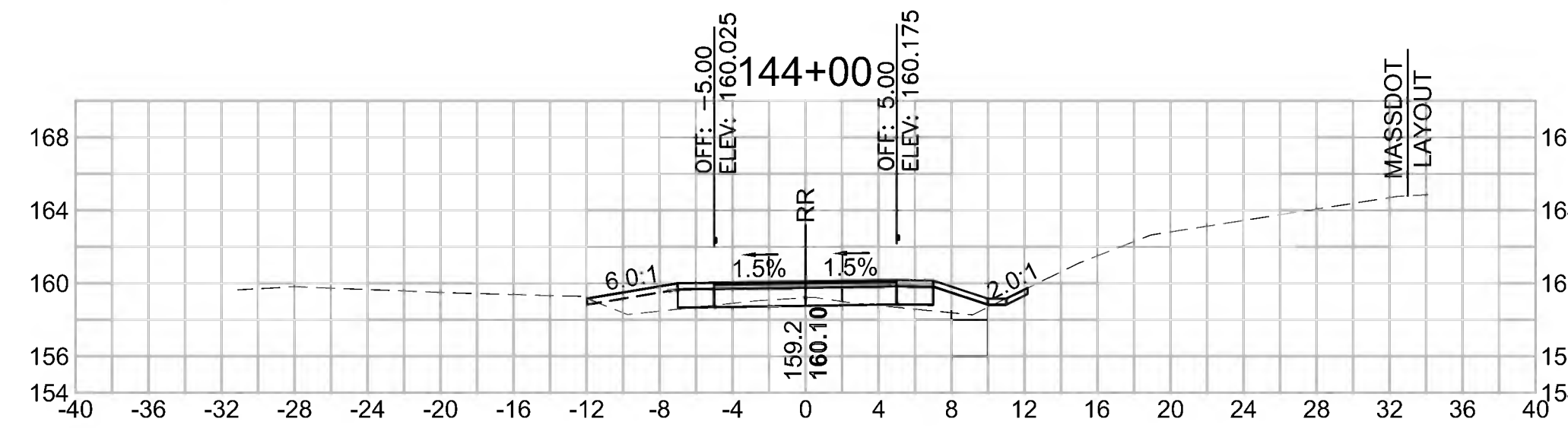

Total Volume at Station 142+00.00

Cut Area (SF)	14.437
Fill Area (SF)	1.258
Cut Vol (CF)	29.347
Fill Vol (CF)	1.9
Cum Cut Vol (CF)	3325.375
Cum Fill Vol (CF)	1500.7
Net Vol (CF)	1824.7

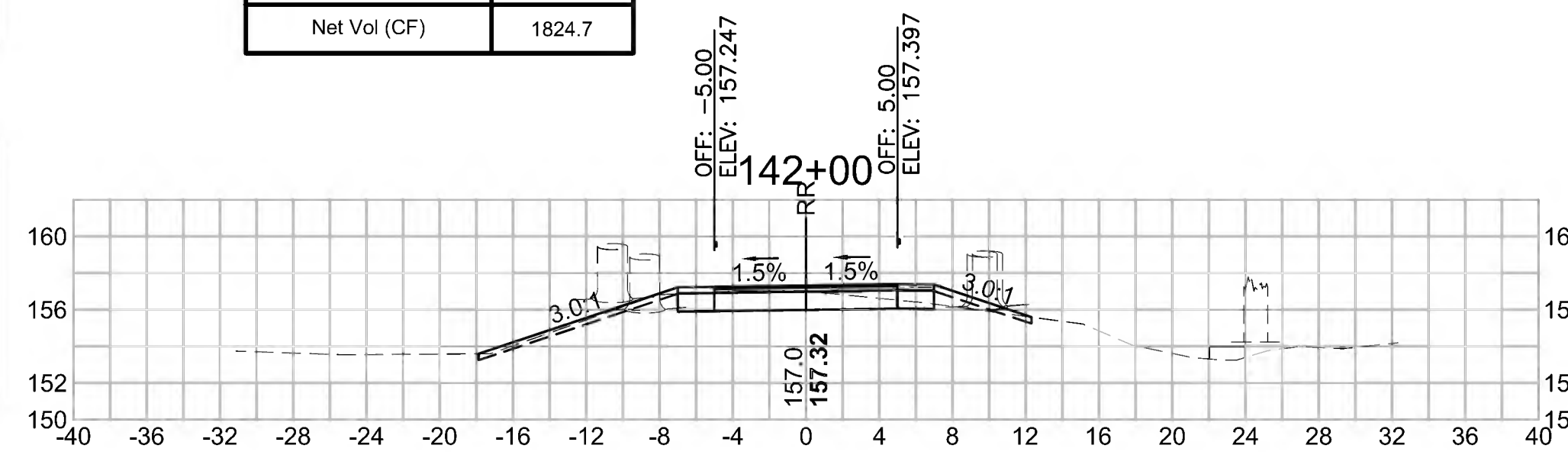

Total Volume at Station 143+50.00

Cut Area (SF)	4.054
Fill Area (SF)	6.653
Cut Vol (CF)	27.326
Fill Vol (CF)	6.2
Cum Cut Vol (CF)	3408.354
Cum Fill Vol (CF)	1510.3
Net Vol (CF)	1898.0

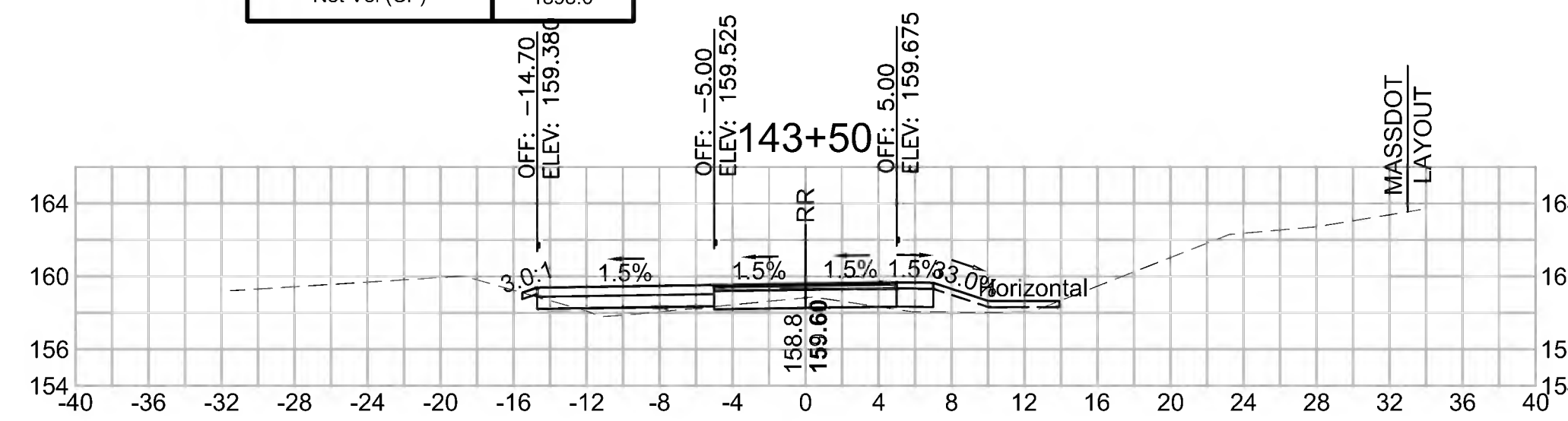

Total Volume at Station 141+50.00

Cut Area (SF)	17.257
Fill Area (SF)	0.838
Cut Vol (CF)	43.074
Fill Vol (CF)	0.8
Cum Cut Vol (CF)	3296.029
Cum Fill Vol (CF)	1498.7
Net Vol (CF)	1797.3

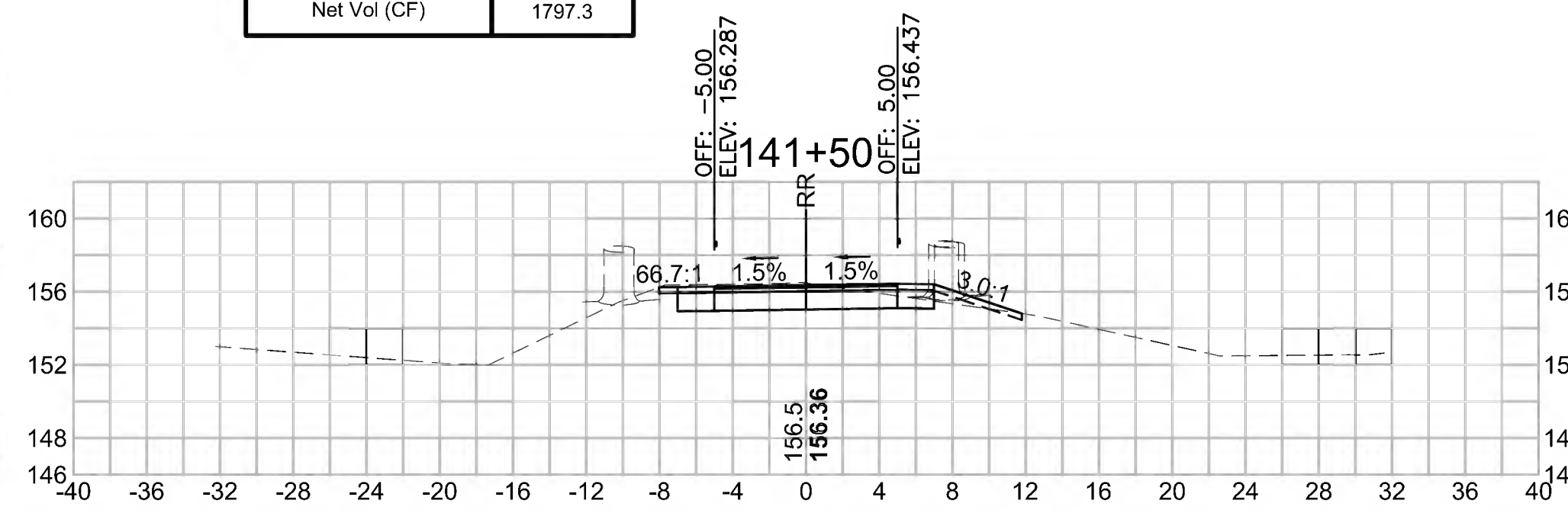

Total Volume at Station 143+00.00

Cut Area (SF)	25.458
Fill Area (SF)	0.000
Cut Vol (CF)	32.929
Fill Vol (CF)	1.2
Cum Cut Vol (CF)	3381.029
Cum Fill Vol (CF)	1504.2
Net Vol (CF)	1876.8

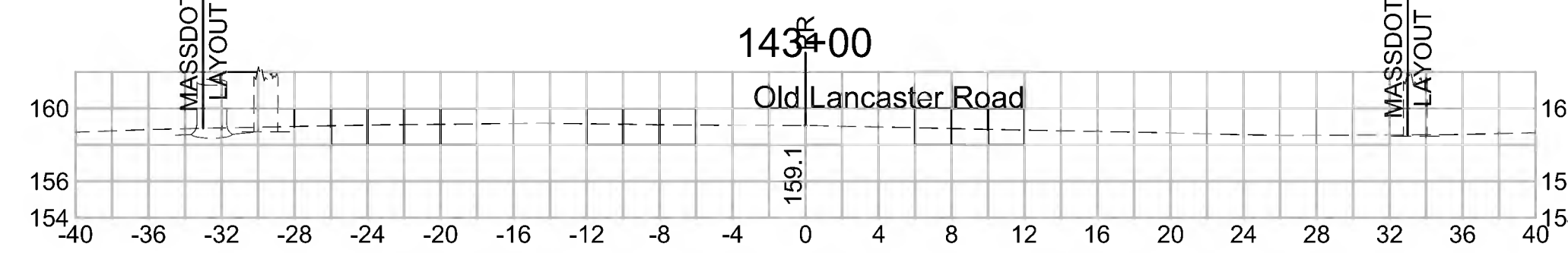

Total Volume at Station 144+50.00

Cut Area (SF)	6.791
Fill Area (SF)	5.125
Cut Vol (CF)	9.093
Fill Vol (CF)	11.1
Cum Cut Vol (CF)	3424.005
Cum Fill Vol (CF)	1534.0
Net Vol (CF)	1890.0

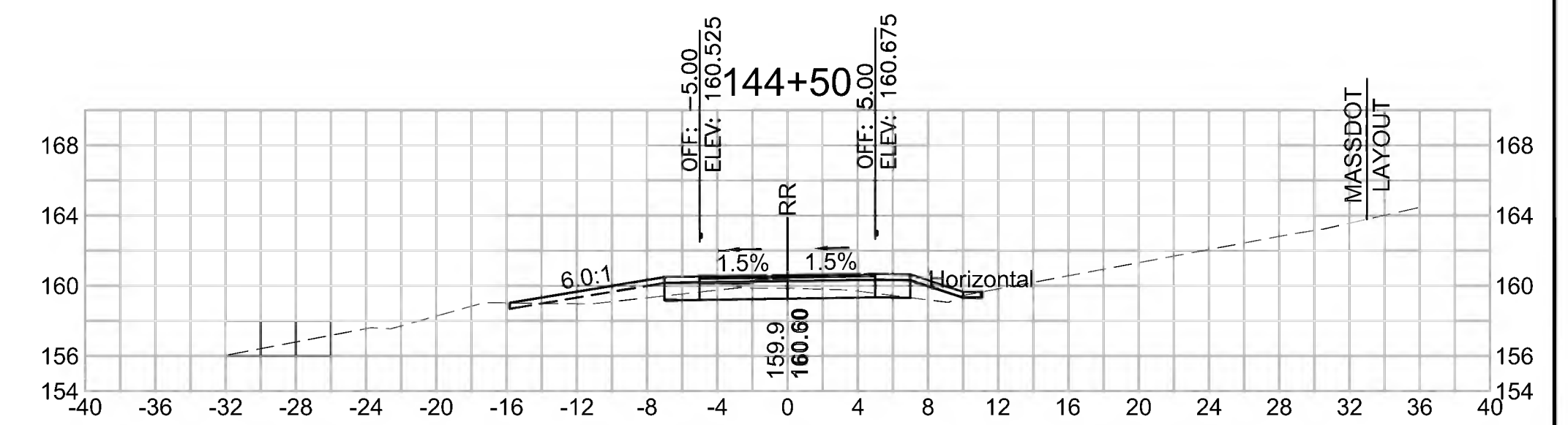

SUDBURY
BRUCE FREEMAN RAIL TRAIL

STATE	FED. AID PROJ. NO.	SHEET NO.	TOTAL SHEETS
MA	XXX-XXXX(XXX)X	255	319
PROJECT FILE NO. 608164			

CROSS SECTIONS

608164.XSEC(CROSS SECTION LAYOUTS).DWG 18-Feb-2022

Total Volume at Station 146+00.00	
Cut Area (SF)	3,780
Fill Area (SF)	31,945
Cut Vol (CF)	7.5
Fill Vol (CF)	37.6
Cum Cut Vol (CF)	3448.5
Cum Fill Vol (CF)	1296.6
Net Vol (CF)	2151.9

Total Volume at Station 147+50.00	
Cut Area (SF)	0.222
Fill Area (SF)	84,139
Cut Vol (CF)	0.4
Fill Vol (CF)	149.8
Cum Cut Vol (CF)	3453.1
Cum Fill Vol (CF)	1677.5
Net Vol (CF)	1775.5

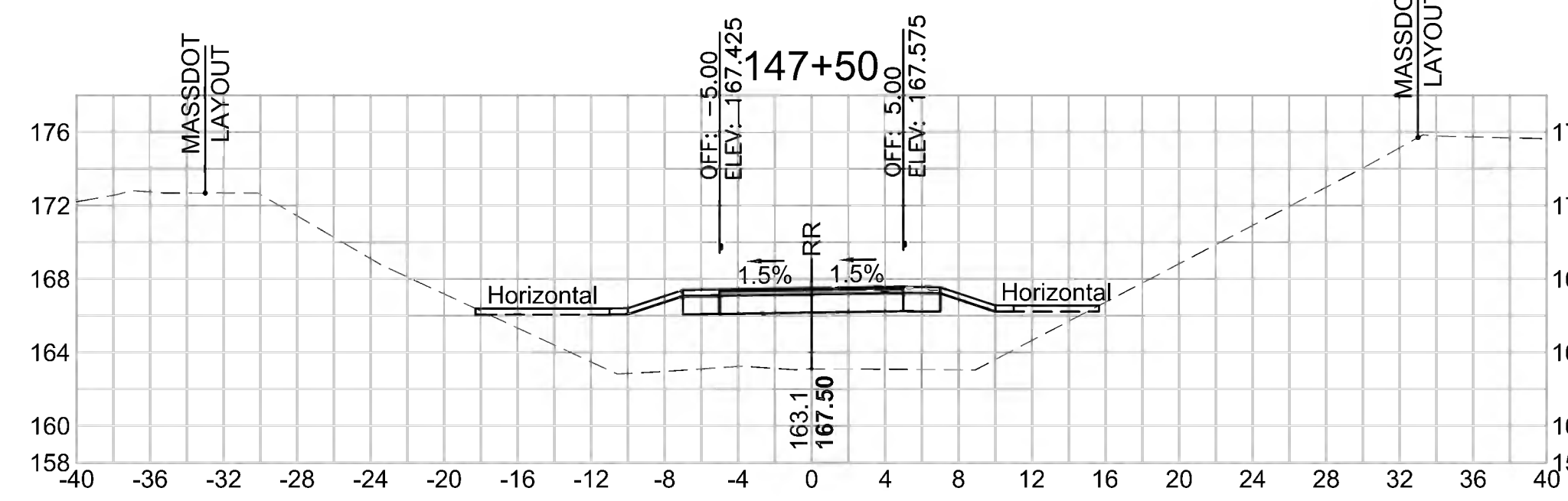
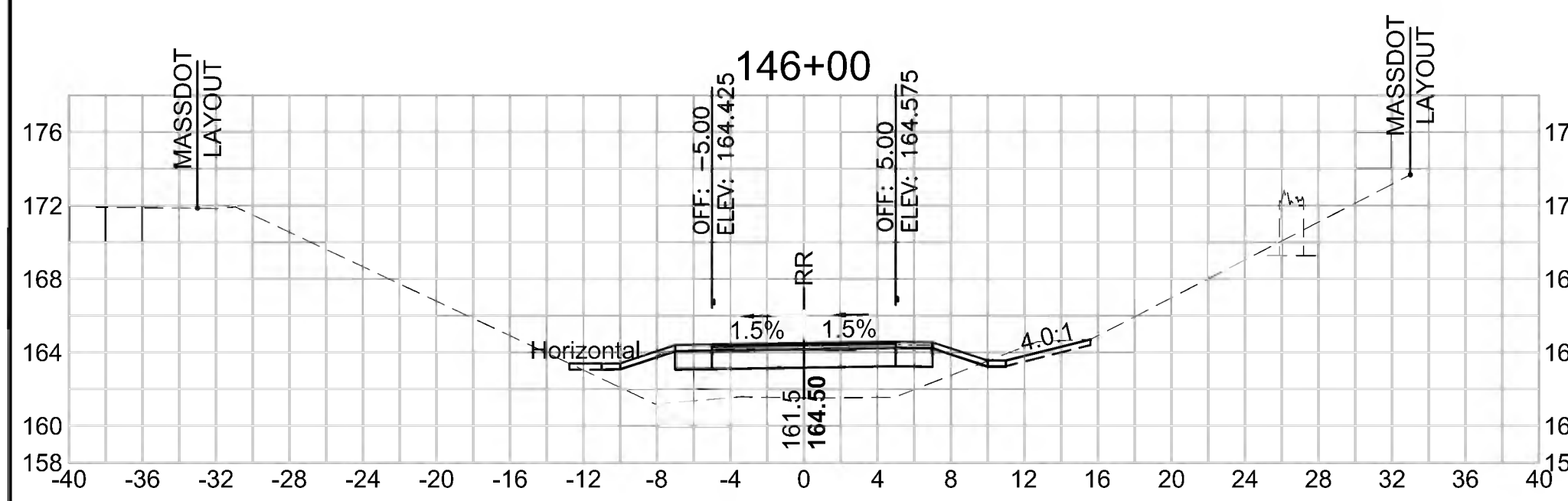

Total Volume at Station 145+50.00	
Cut Area (SF)	4,316
Fill Area (SF)	8,617
Cut Vol (CF)	10.5
Fill Vol (CF)	12.5
Cum Cut Vol (CF)	3441.0
Cum Fill Vol (CF)	1259.1
Net Vol (CF)	2182.0

Total Volume at Station 147+00.00	
Cut Area (SF)	0.237
Fill Area (SF)	77,656
Cut Vol (CF)	0.4
Fill Vol (CF)	136.7
Cum Cut Vol (CF)	3452.6
Cum Fill Vol (CF)	1527.7
Net Vol (CF)	1924.9

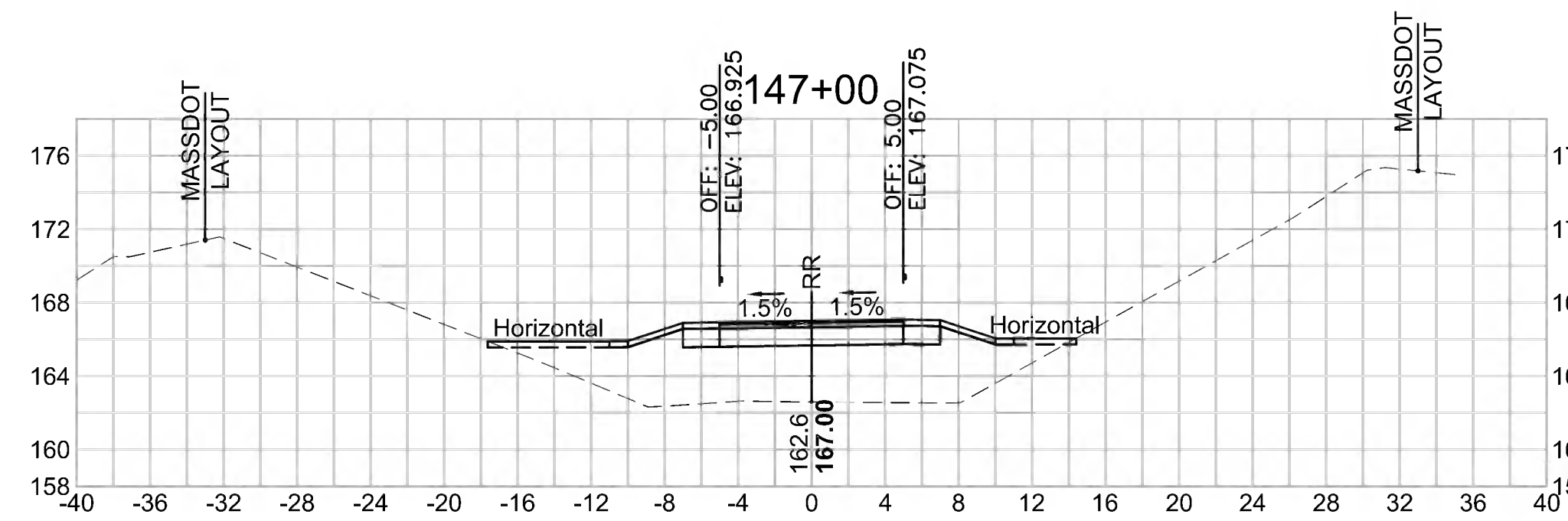
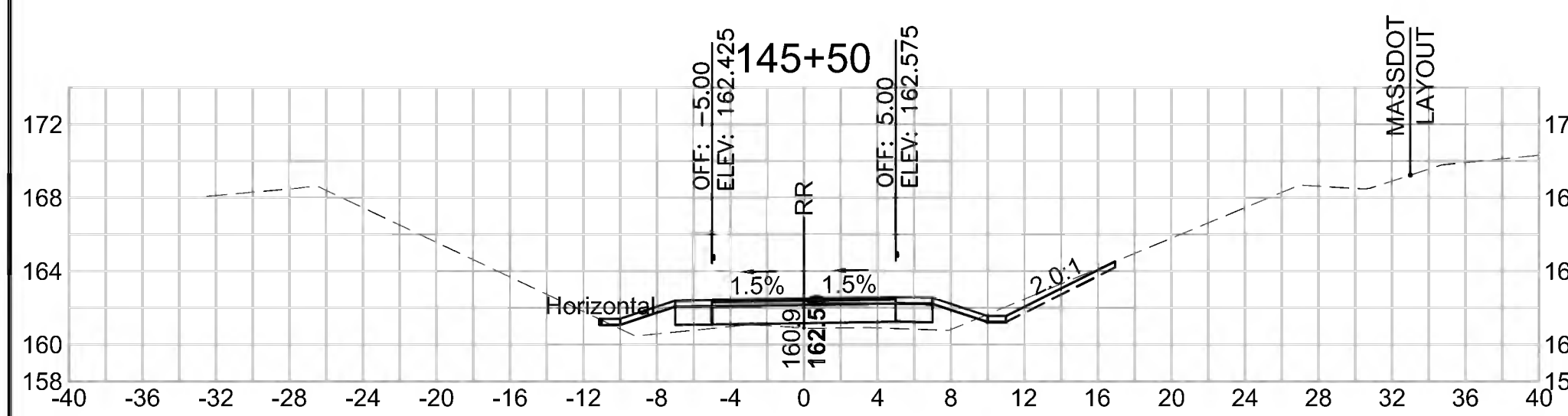

Total Volume at Station 145+00.00	
Cut Area (SF)	6,999
Fill Area (SF)	4,897
Cut Vol (CF)	12.8
Fill Vol (CF)	9.3
Cum Cut Vol (CF)	3430.5
Cum Fill Vol (CF)	1246.5
Net Vol (CF)	2184.0

Total Volume at Station 146+50.00	
Cut Area (SF)	0.213
Fill Area (SF)	69,990
Cut Vol (CF)	3.7
Fill Vol (CF)	94.4
Cum Cut Vol (CF)	3452.2
Cum Fill Vol (CF)	1391.0
Net Vol (CF)	2061.2

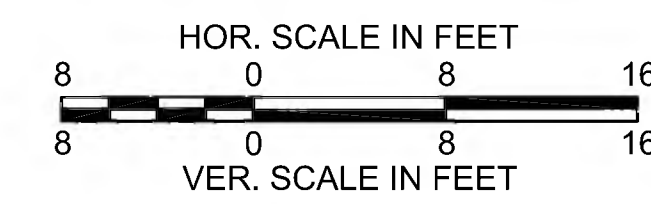
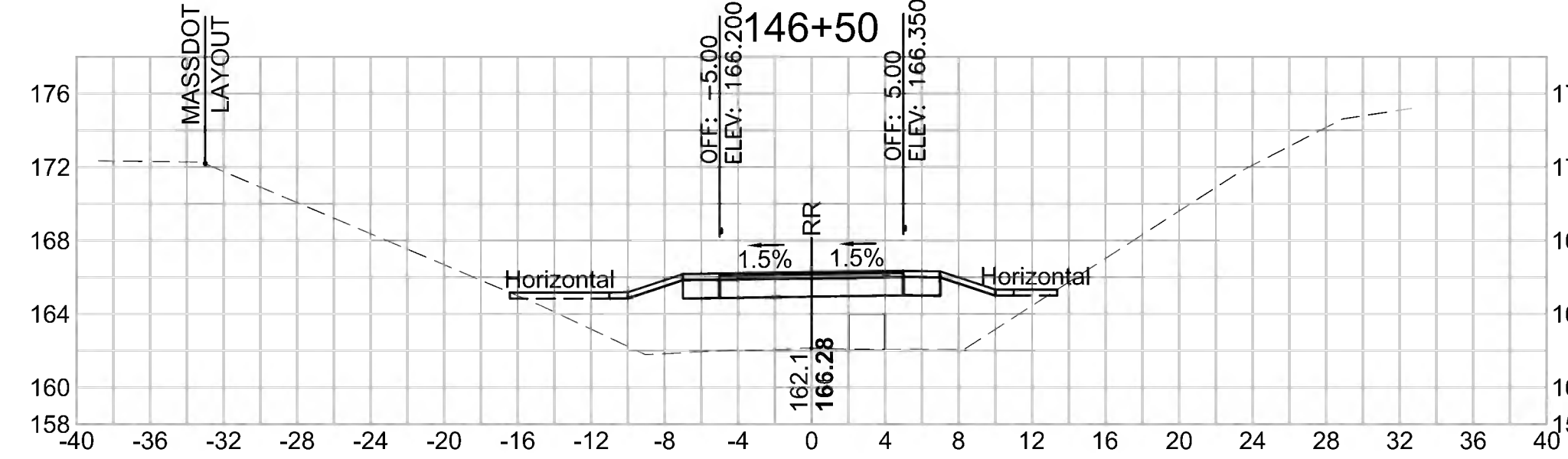
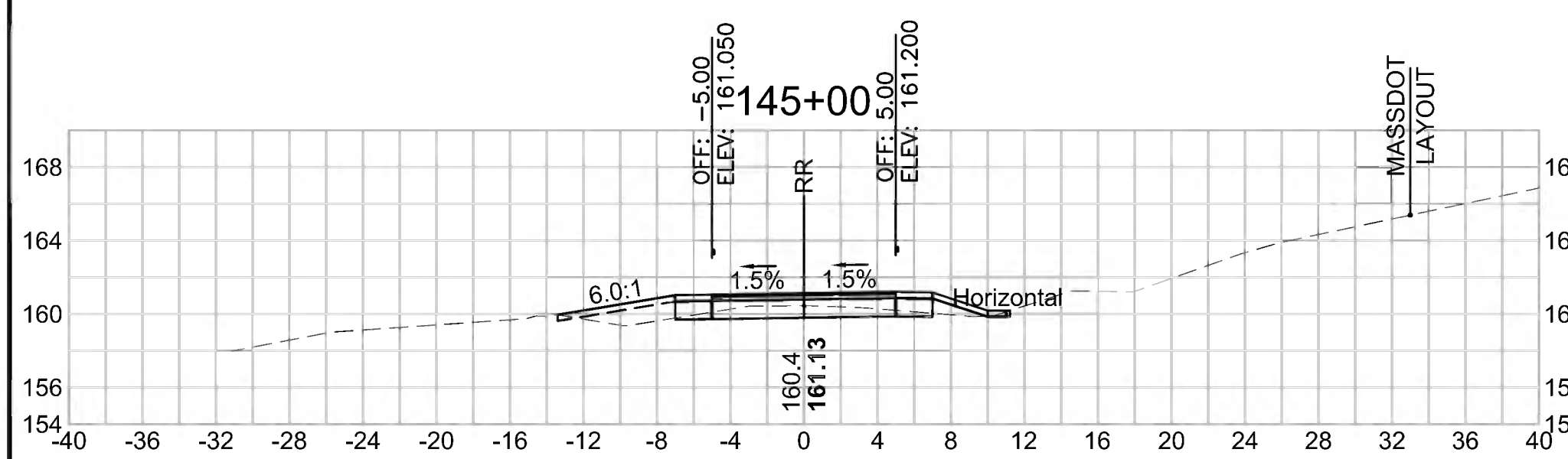

CROSS SECTIONS

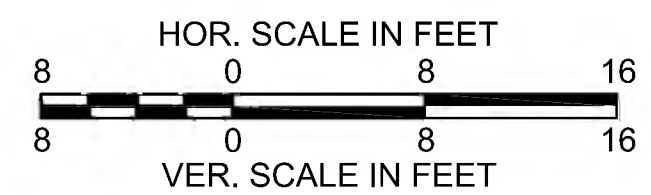

Total Volume at Station 149+00.00

Cut Area (SF)	0.249
Fill Area (SF)	82.781
Cut Vol (CF)	0.4
Fill Vol (CF)	153.1
Cum Cut Vol (CF)	3454.2
Cum Fill Vol (CF)	2150.8
Net Vol (CF)	1303.5

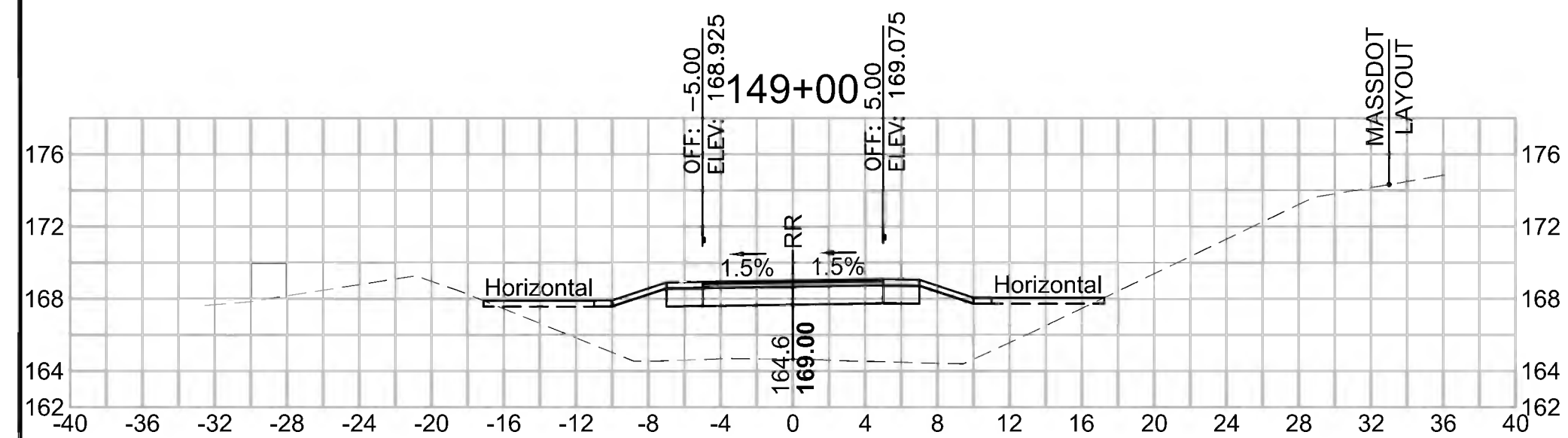

Total Volume at Station 150+50.00

Cut Area (SF)	0.610
Fill Area (SF)	84.824
Cut Vol (CF)	0.8
Fill Vol (CF)	155.0
Cum Cut Vol (CF)	3456.1
Cum Fill Vol (CF)	2618.4
Net Vol (CF)	837.7

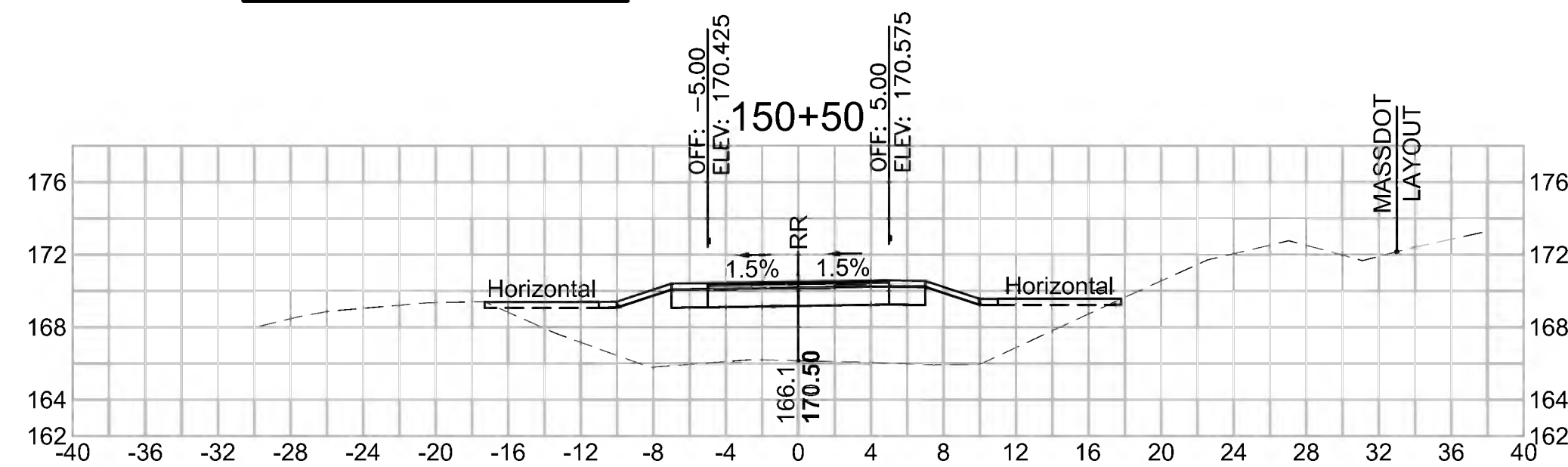

Total Volume at Station 148+50.00

Cut Area (SF)	0.210
Fill Area (SF)	82.557
Cut Vol (CF)	0.4
Fill Vol (CF)	159.3
Cum Cut Vol (CF)	3453.8
Cum Fill Vol (CF)	1997.7
Net Vol (CF)	1456.2

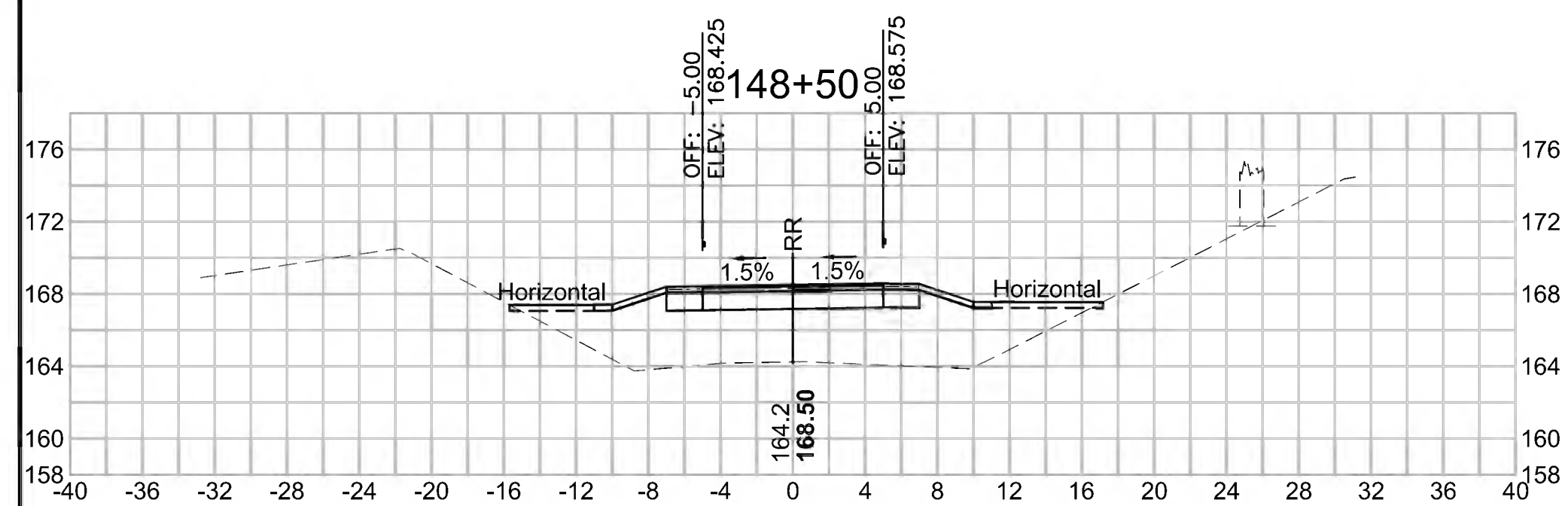

Total Volume at Station 150+00.00

Cut Area (SF)	0.269
Fill Area (SF)	82.543
Cut Vol (CF)	0.5
Fill Vol (CF)	156.2
Cum Cut Vol (CF)	3455.2
Cum Fill Vol (CF)	2463.4
Net Vol (CF)	991.8

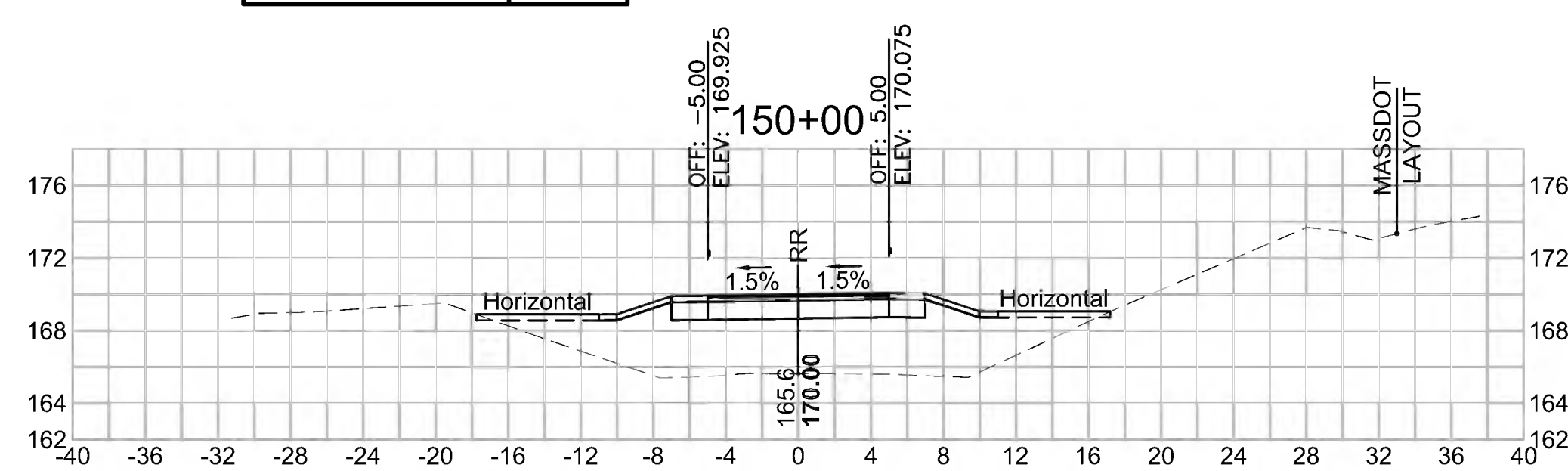

Total Volume at Station 151+50.00

Cut Area (SF)	0.259
Fill Area (SF)	42.987
Cut Vol (CF)	0.4
Fill Vol (CF)	109.5
Cum Cut Vol (CF)	3457.3
Cum Fill Vol (CF)	2876.0
Net Vol (CF)	581.3

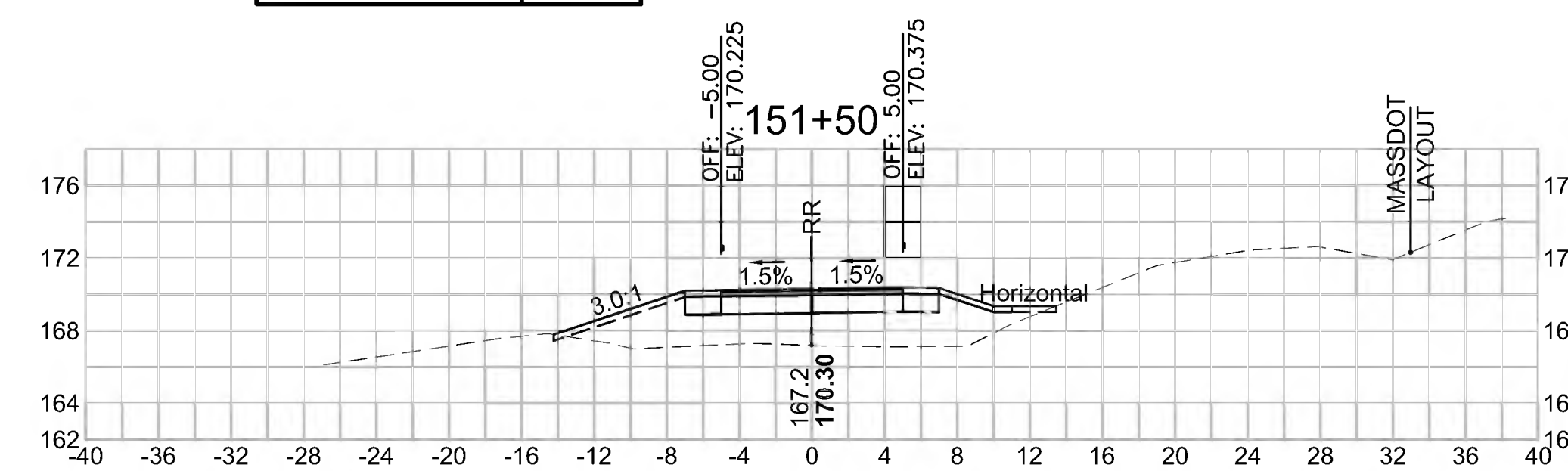

Total Volume at Station 148+00.00

Cut Area (SF)	0.199
Fill Area (SF)	89.527
Cut Vol (CF)	0.4
Fill Vol (CF)	160.8
Cum Cut Vol (CF)	3453.4
Cum Fill Vol (CF)	1838.3
Net Vol (CF)	1615.1

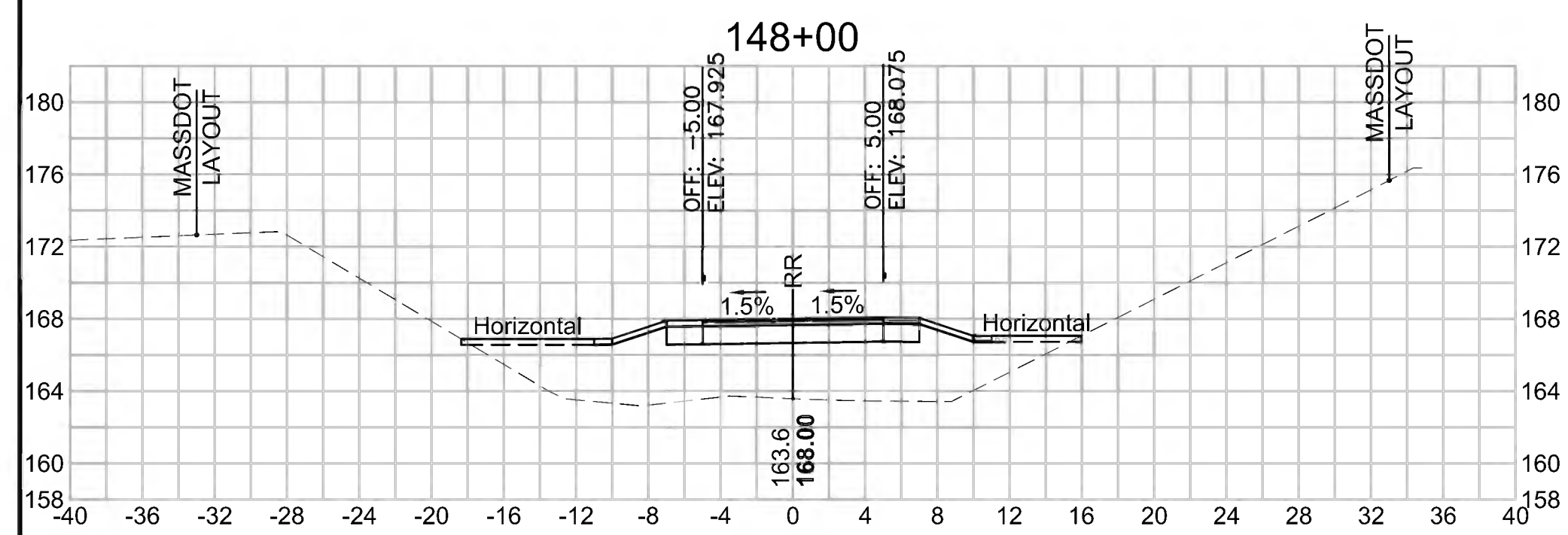

Total Volume at Station 149+50.00

Cut Area (SF)	0.280
Fill Area (SF)	86.165
Cut Vol (CF)	0.5
Fill Vol (CF)	156.4
Cum Cut Vol (CF)	3454.7
Cum Fill Vol (CF)	2307.2
Net Vol (CF)	1147.6

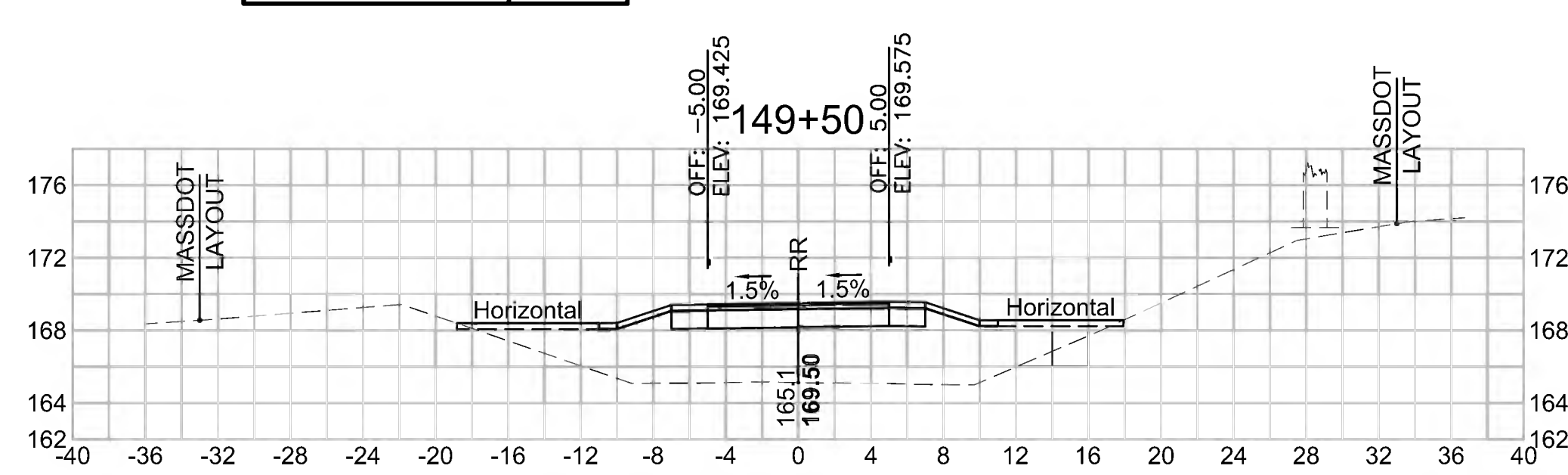

Total Volume at Station 151+00.00

Cut Area (SF)	0.219
Fill Area (SF)	75.223
Cut Vol (CF)	0.8
Fill Vol (CF)	148.2
Cum Cut Vol (CF)	3456.8
Cum Fill Vol (CF)	2766.6
Net Vol (CF)	690.3

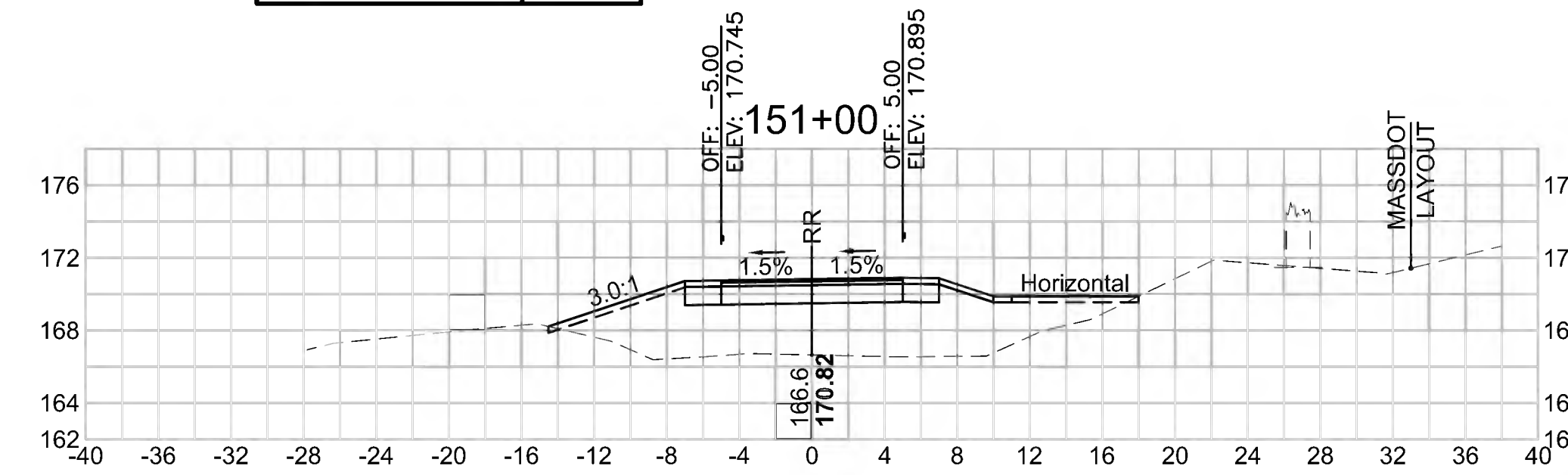

SUDBURY
BRUCE FREEMAN RAIL TRAIL

STATE	FED. AID PROJ. NO.	SHEET NO.	TOTAL SHEETS
MA	XXX-XXX(XXX)X	257	319
PROJECT FILE NO. 608164			

CROSS SECTIONS

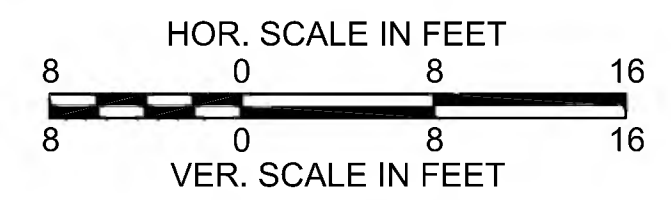

Total Volume at Station 153+00.00

Cut Area (SF)	6.879
Fill Area (SF)	5.832
Cut Vol (CF)	10.3
Fill Vol (CF)	8.4
Cum Cut Vol (CF)	3472.5
Cum Fill Vol (CF)	2953.8
Net Vol (CF)	518.7

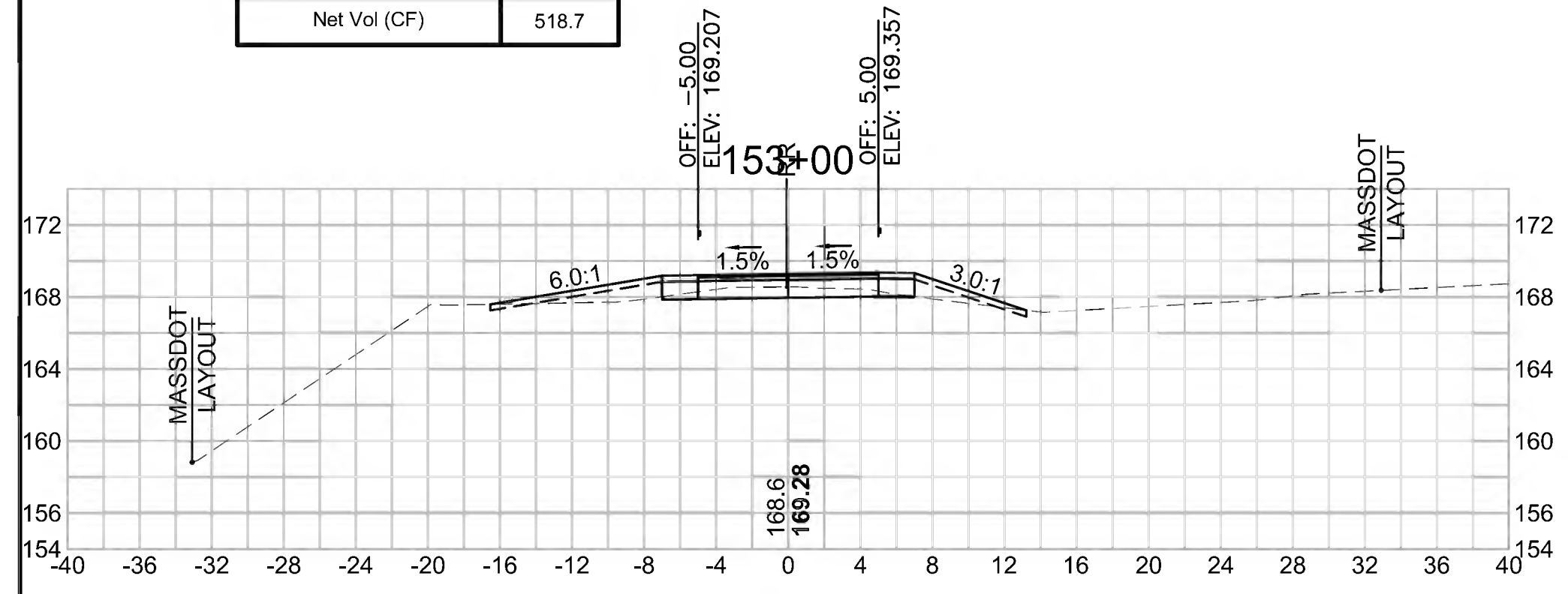

Total Volume at Station 154+50.00

Cut Area (SF)	11.824
Fill Area (SF)	0.877
Cut Vol (CF)	18.9
Fill Vol (CF)	7.7
Cum Cut Vol (CF)	3519.1
Cum Fill Vol (CF)	2990.7
Net Vol (CF)	528.4

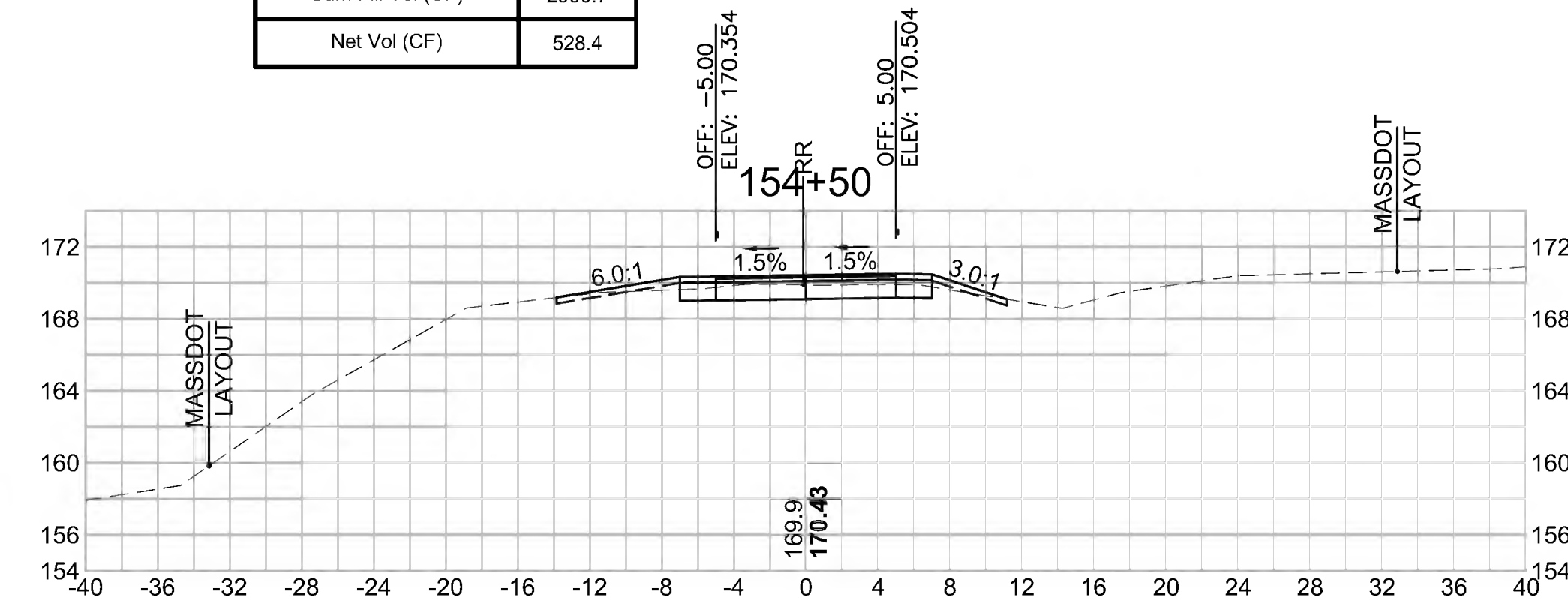

Total Volume at Station 156+00.00

Cut Area (SF)	15.407
Fill Area (SF)	0.672
Cut Vol (CF)	27.4
Fill Vol (CF)	0.7
Cum Cut Vol (CF)	3592.9
Cum Fill Vol (CF)	2993.4
Net Vol (CF)	599.5

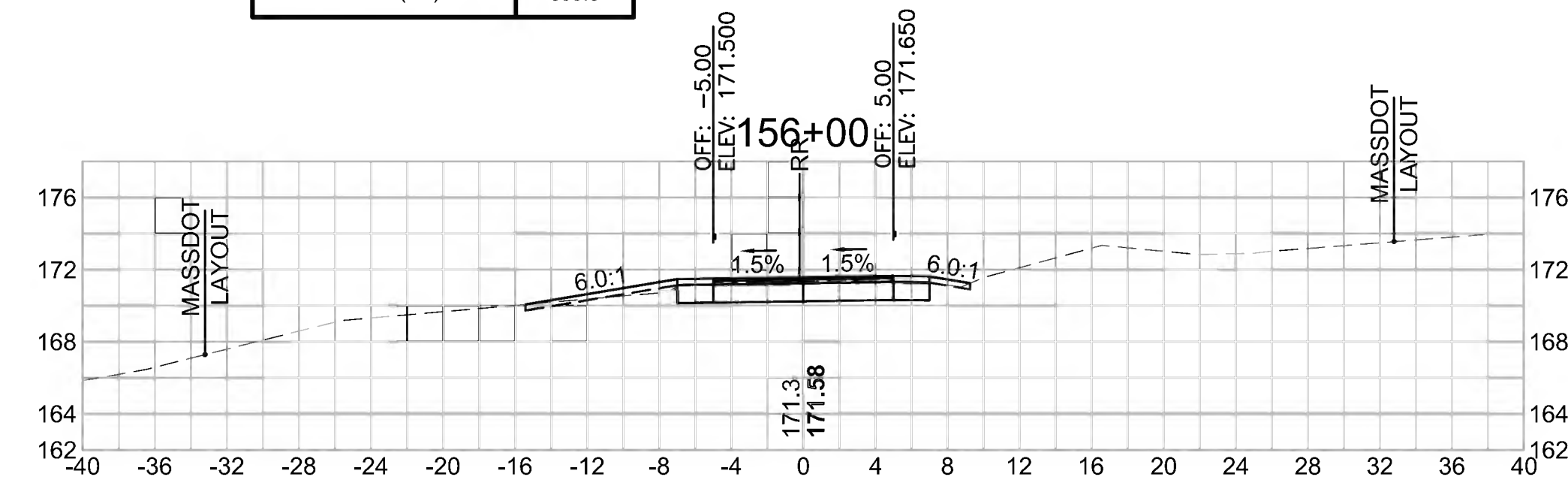

Total Volume at Station 152+50.00

Cut Area (SF)	4.291
Fill Area (SF)	3.199
Cut Vol (CF)	4.3
Fill Vol (CF)	16.3
Cum Cut Vol (CF)	3462.2
Cum Fill Vol (CF)	2945.4
Net Vol (CF)	516.7

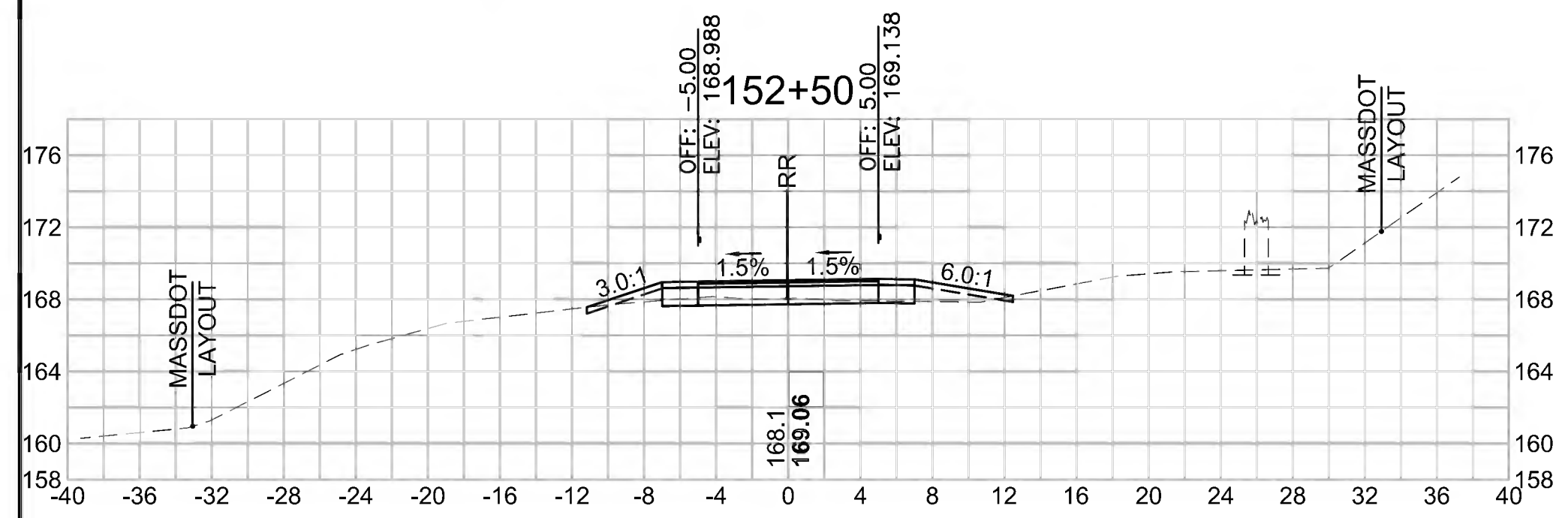

Total Volume at Station 154+00.00

Cut Area (SF)	8.619
Fill Area (SF)	7.408
Cut Vol (CF)	14.6
Fill Vol (CF)	15.3
Cum Cut Vol (CF)	3500.1
Cum Fill Vol (CF)	2983.0
Net Vol (CF)	517.1

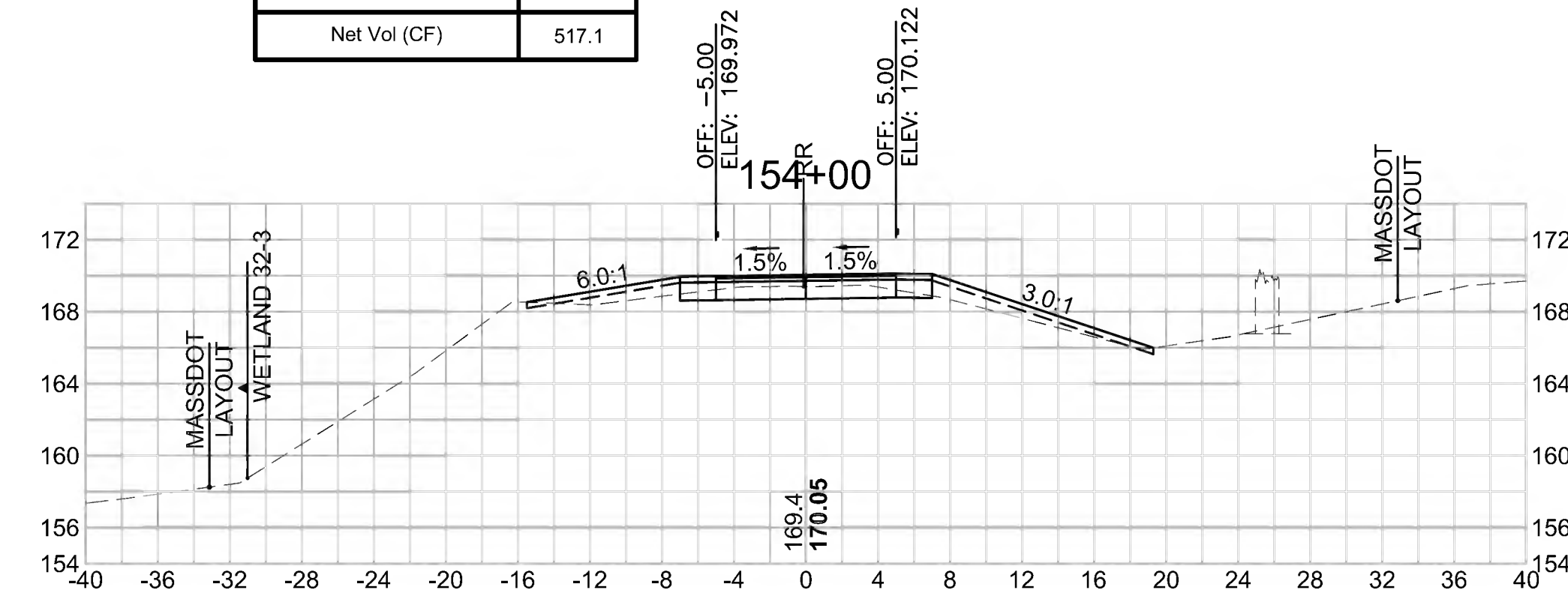

Total Volume at Station 155+50.00

Cut Area (SF)	14.224
Fill Area (SF)	0.060
Cut Vol (CF)	24.3
Fill Vol (CF)	0.6
Cum Cut Vol (CF)	3565.5
Cum Fill Vol (CF)	2992.7
Net Vol (CF)	572.7

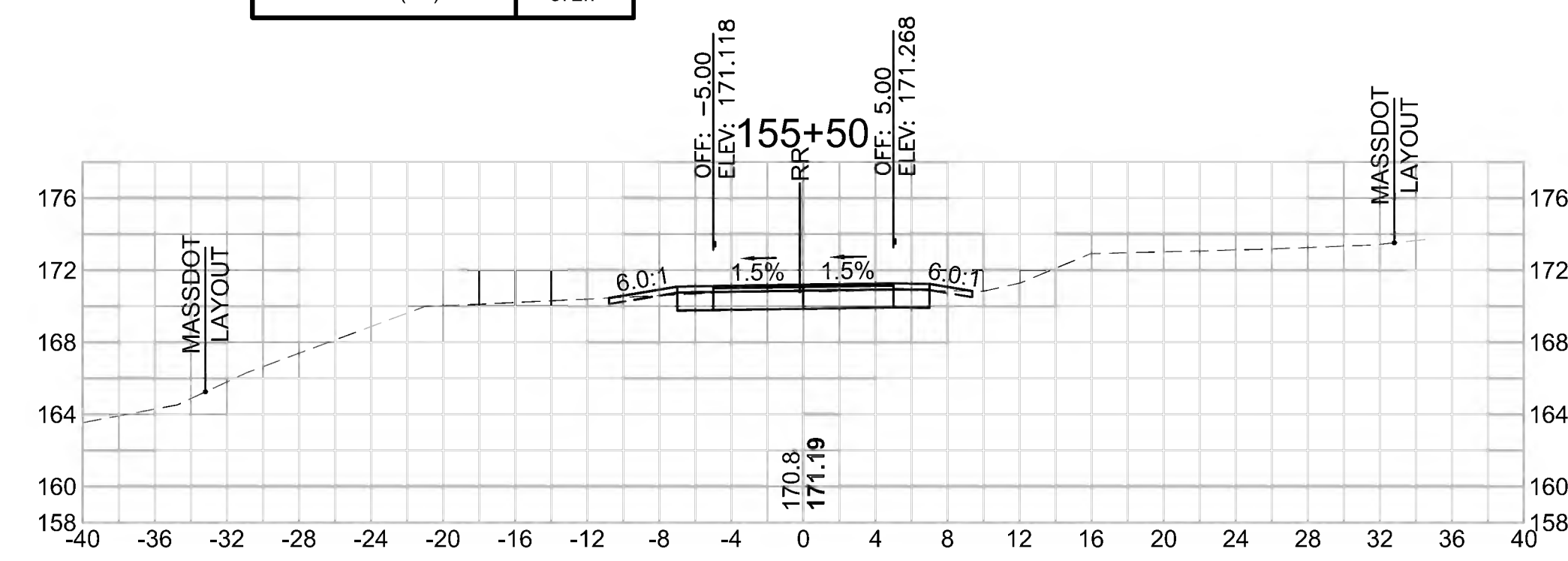

Total Volume at Station 152+00.00

Cut Area (SF)	0.363
Fill Area (SF)	14.405
Cut Vol (CF)	0.6
Fill Vol (CF)	53.1
Cum Cut Vol (CF)	3457.8
Cum Fill Vol (CF)	2929.1
Net Vol (CF)	528.7

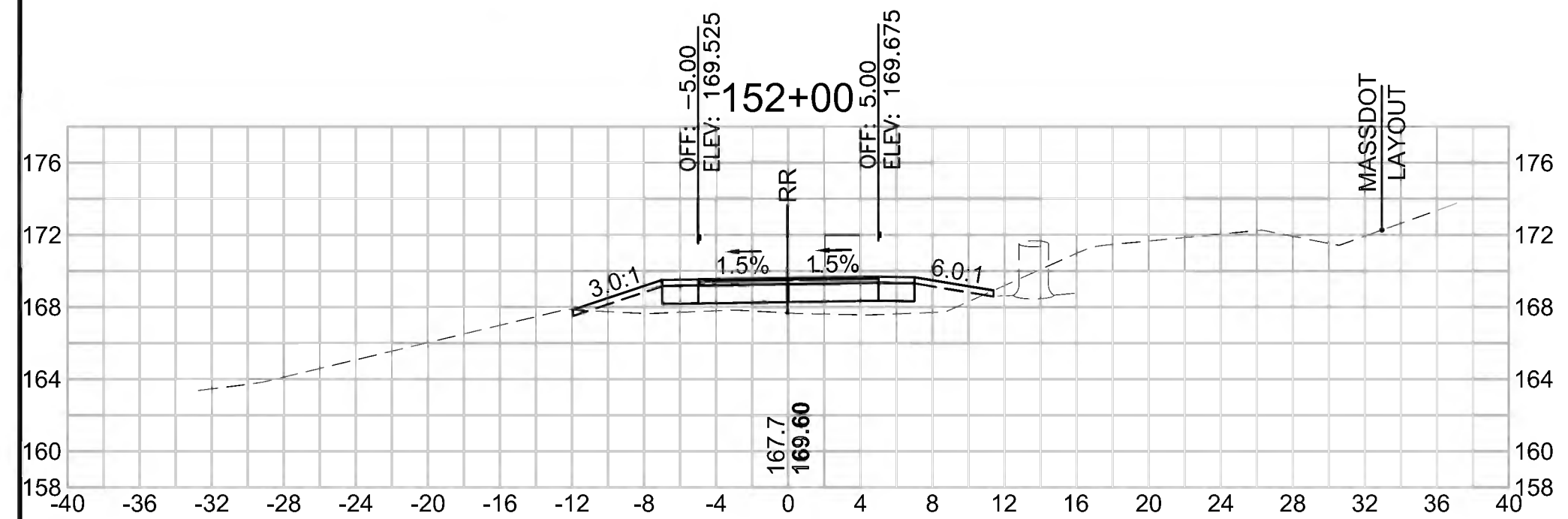

Total Volume at Station 153+50.00

Cut Area (SF)	7.183
Fill Area (SF)	9.162
Cut Vol (CF)	13.0
Fill Vol (CF)	13.9
Cum Cut Vol (CF)	3485.5
Cum Fill Vol (CF)	2967.7
Net Vol (CF)	517.8

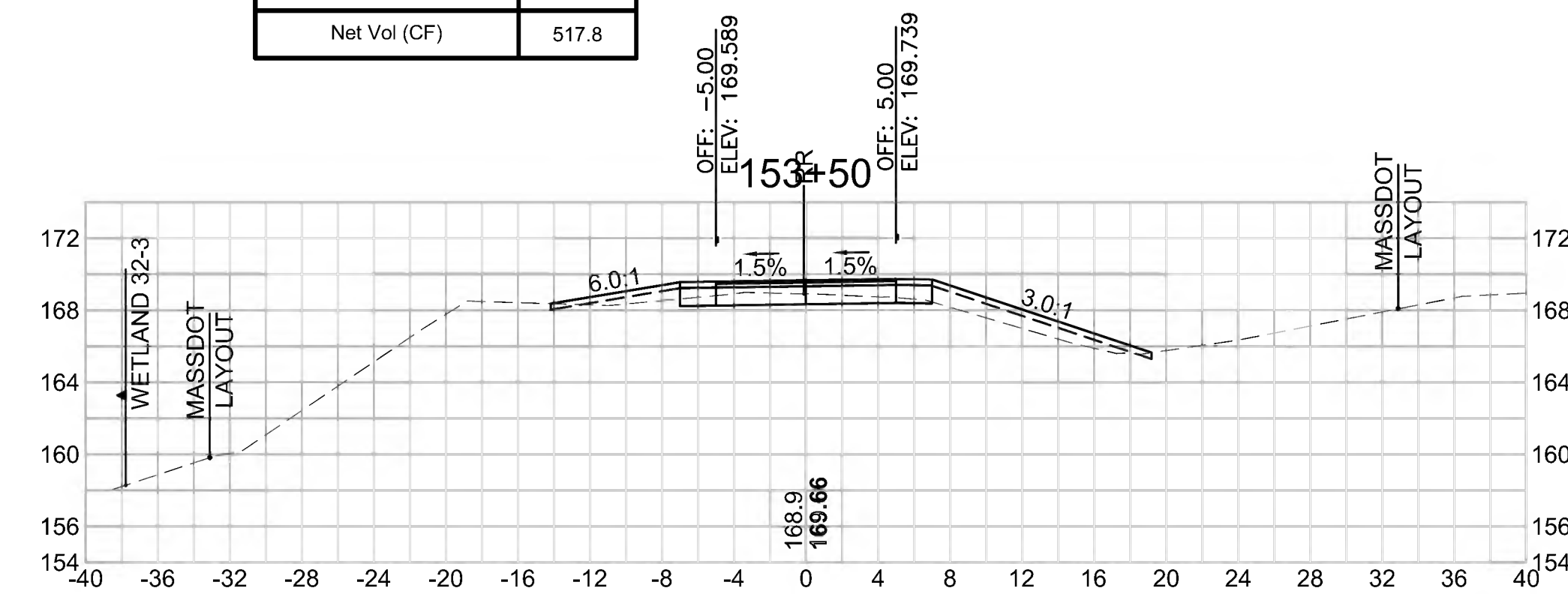

Total Volume at Station 155+00.00

Cut Area (SF)	12.039
Fill Area (SF)	0.631
Cut Vol (CF)	22.1
Fill Vol (CF)	1.4
Cum Cut Vol (CF)	3541.2
Cum Fill Vol (CF)	2992.1
Net Vol (CF)	549.1

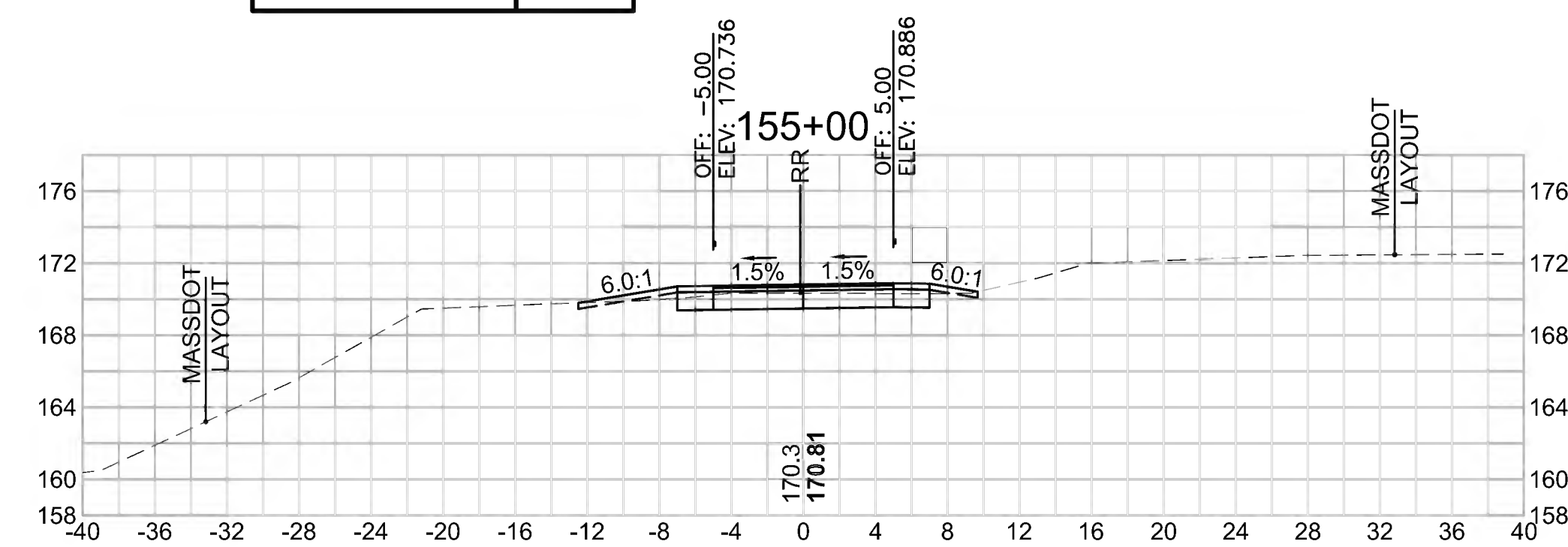

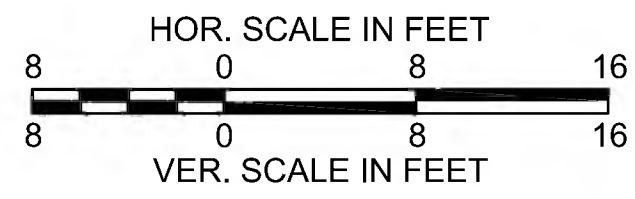

SUDBURY
 BRUCE FREEMAN RAIL TRAIL

STATE	FED. AID PROJ. NO.	SHEET NO.	TOTAL SHEETS
MA	XXX-XXXX(XXX)X	258	319

PROJECT FILE NO. 608164

CROSS SECTIONS

18-Feb-2022 608164_XSEC(CROSS SECTION LAYOUTS).DWG

Total Volume at Station 157+00.00

Cut Area (SF)	19.980
Fill Area (SF)	0.000
Cut Vol (CF)	33.0
Fill Vol (CF)	0.4
Cum Cut Vol (CF)	3654.7
Cum Fill Vol (CF)	2994.9
Net Vol (CF)	659.8

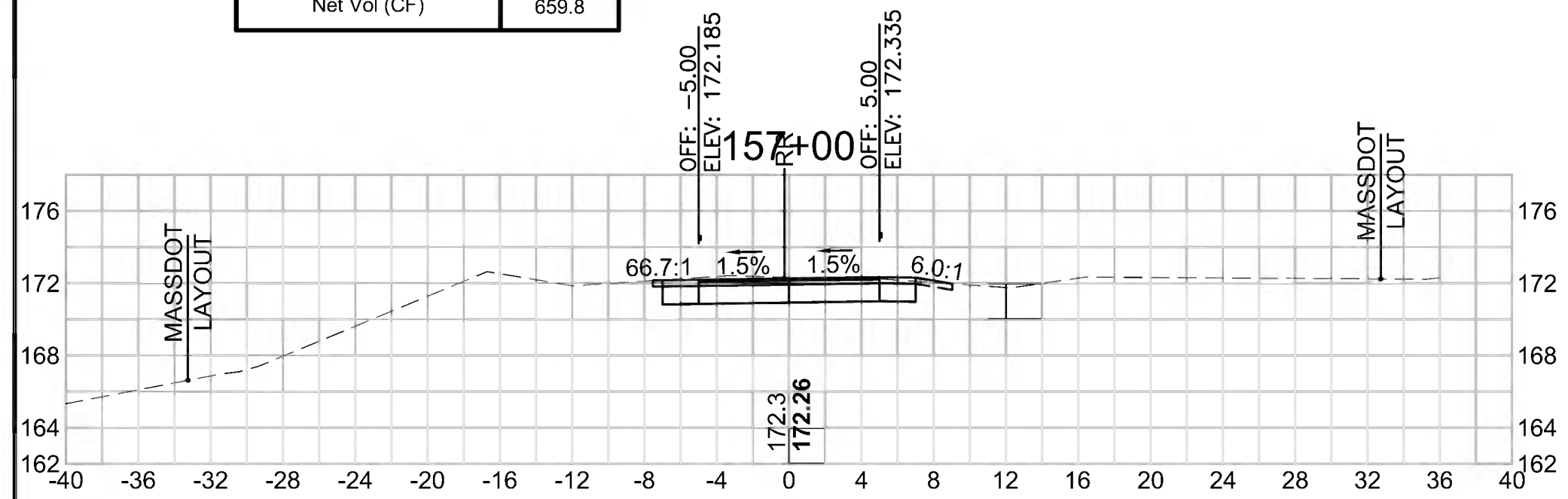

Total Volume at Station 158+00.00

Cut Area (SF)	27.125
Fill Area (SF)	0.000
Cut Vol (CF)	52.4
Fill Vol (CF)	0.0
Cum Cut Vol (CF)	3752.9
Cum Fill Vol (CF)	2994.9
Net Vol (CF)	758.0

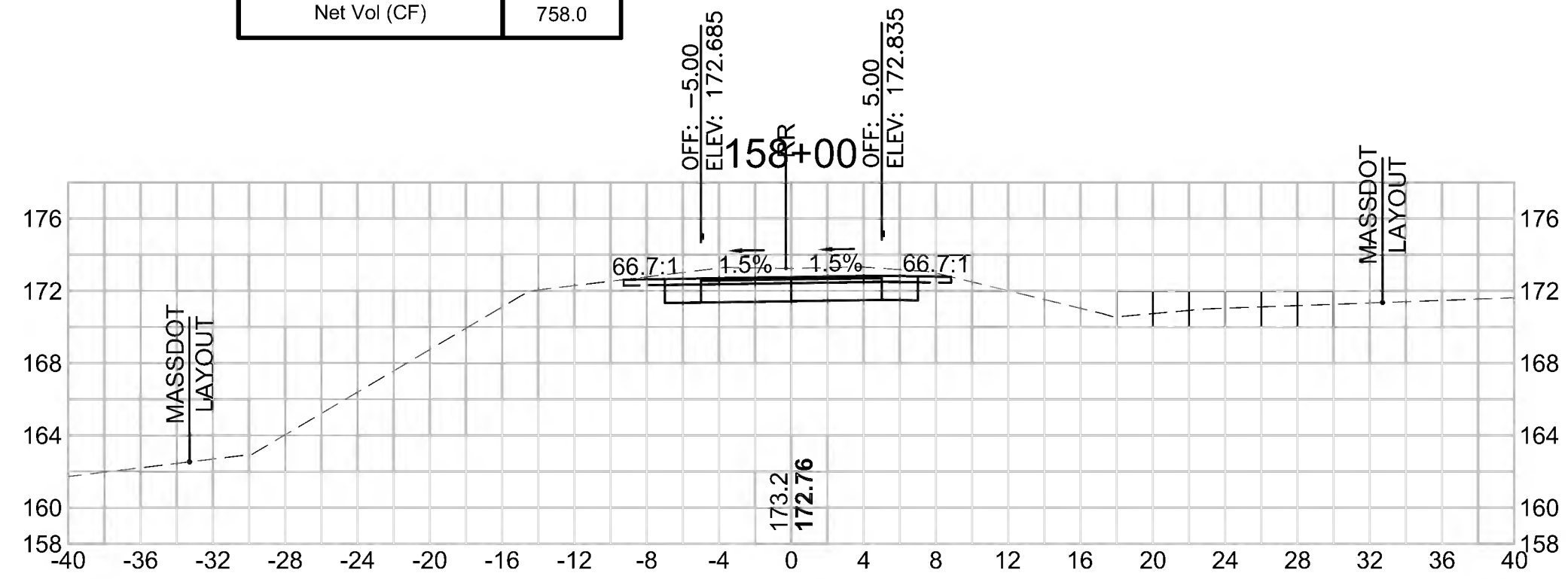

Total Volume at Station 159+00.00

Cut Area (SF)	33.680
Fill Area (SF)	0.000
Cut Vol (CF)	61.6
Fill Vol (CF)	0.0
Cum Cut Vol (CF)	3870.0
Cum Fill Vol (CF)	2994.9
Net Vol (CF)	875.1

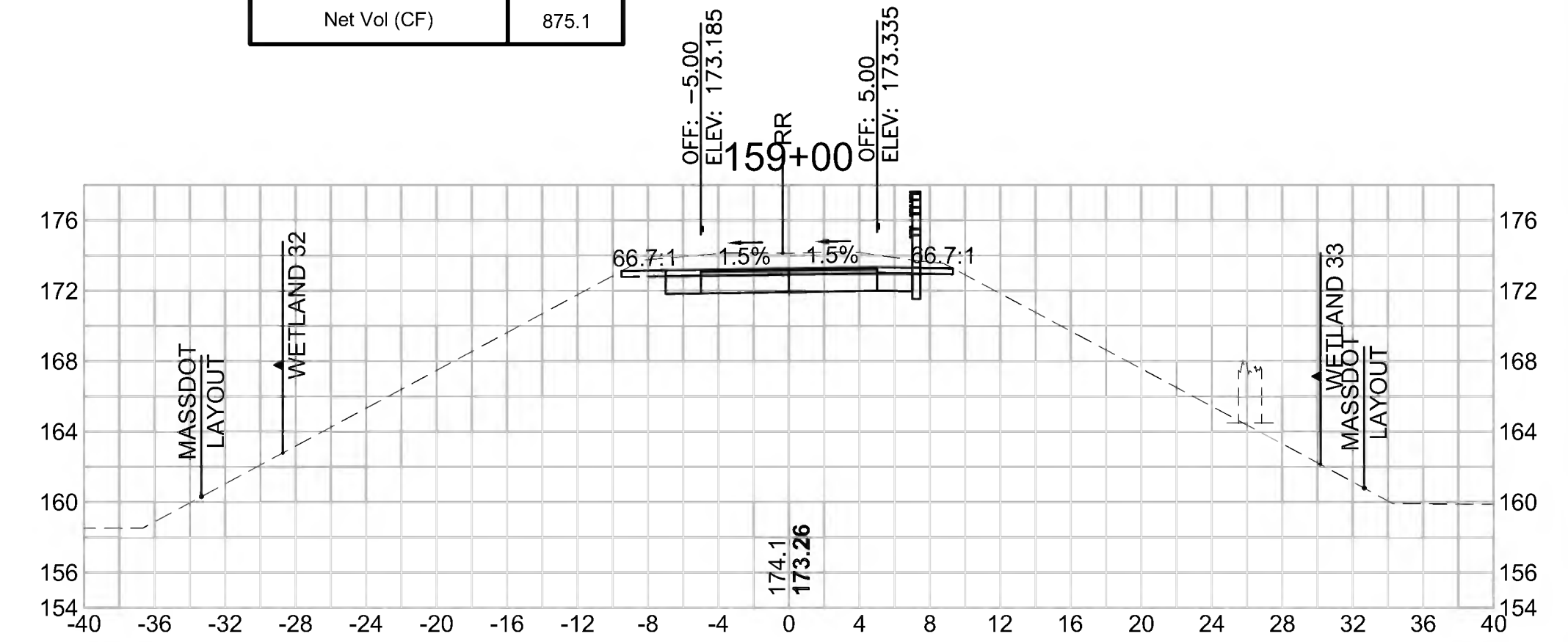

Total Volume at Station 156+50.00

Cut Area (SF)	15.684
Fill Area (SF)	0.452
Cut Vol (CF)	28.8
Fill Vol (CF)	1.0
Cum Cut Vol (CF)	3621.7
Cum Fill Vol (CF)	2994.5
Net Vol (CF)	627.2

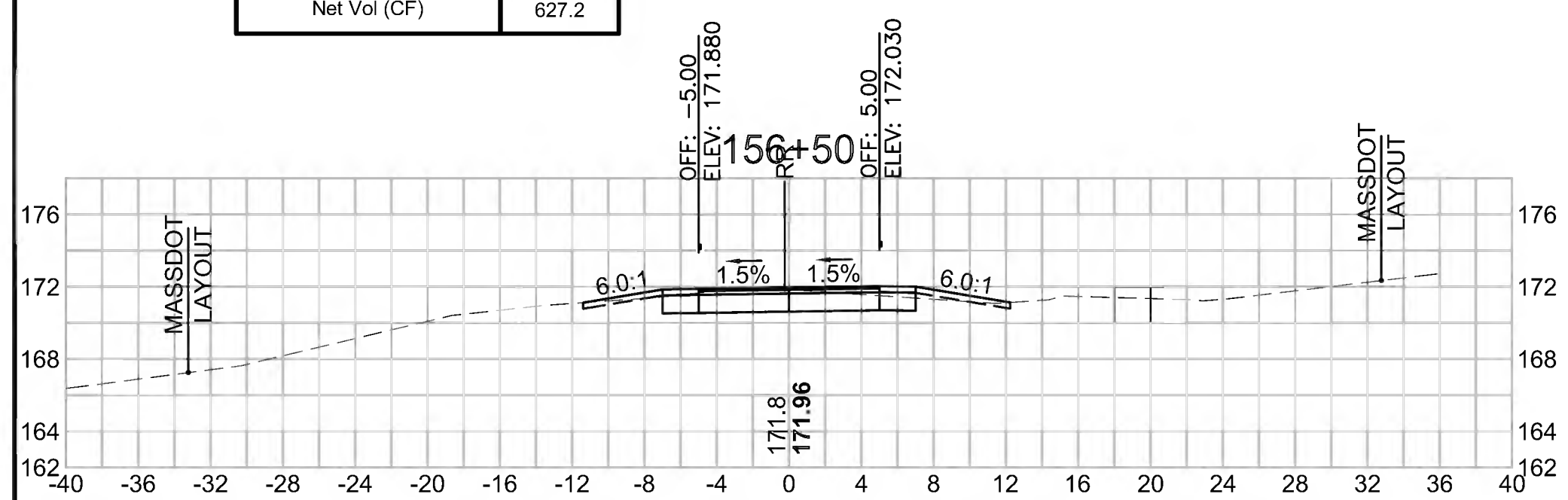

Total Volume at Station 157+50.00

Cut Area (SF)	29.473
Fill Area (SF)	0.000
Cut Vol (CF)	45.8
Fill Vol (CF)	0.0
Cum Cut Vol (CF)	3700.5
Cum Fill Vol (CF)	2994.9
Net Vol (CF)	705.6

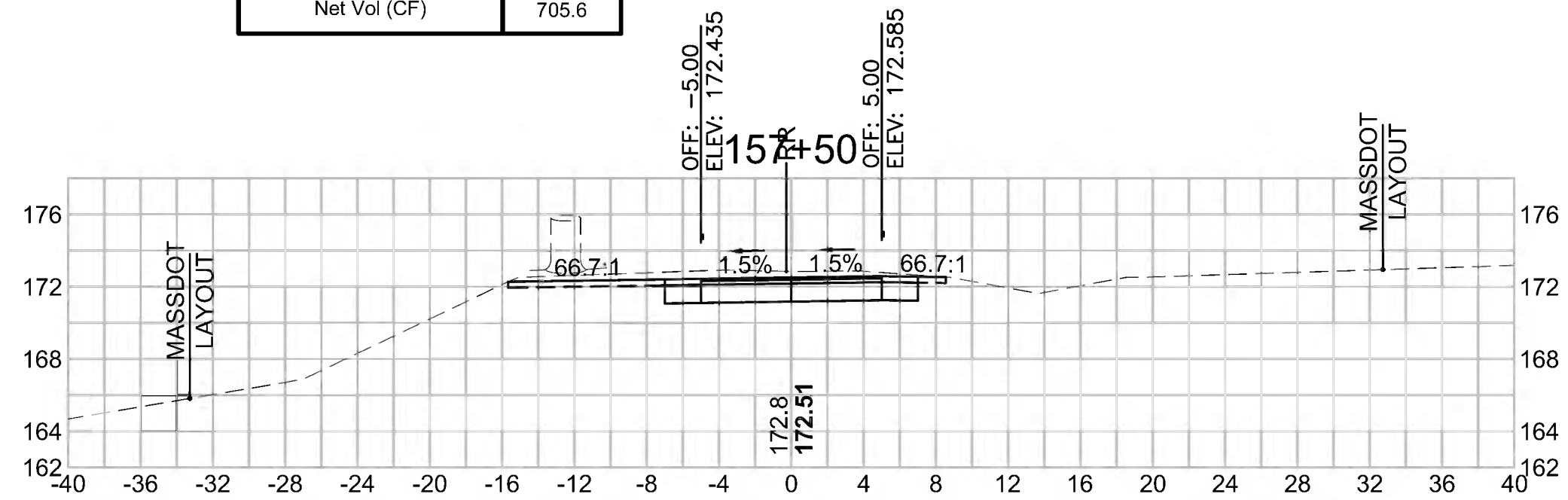

Total Volume at Station 158+50.00

Cut Area (SF)	32.796
Fill Area (SF)	0.000
Cut Vol (CF)	55.5
Fill Vol (CF)	0.0
Cum Cut Vol (CF)	3808.4
Cum Fill Vol (CF)	2994.9
Net Vol (CF)	813.5

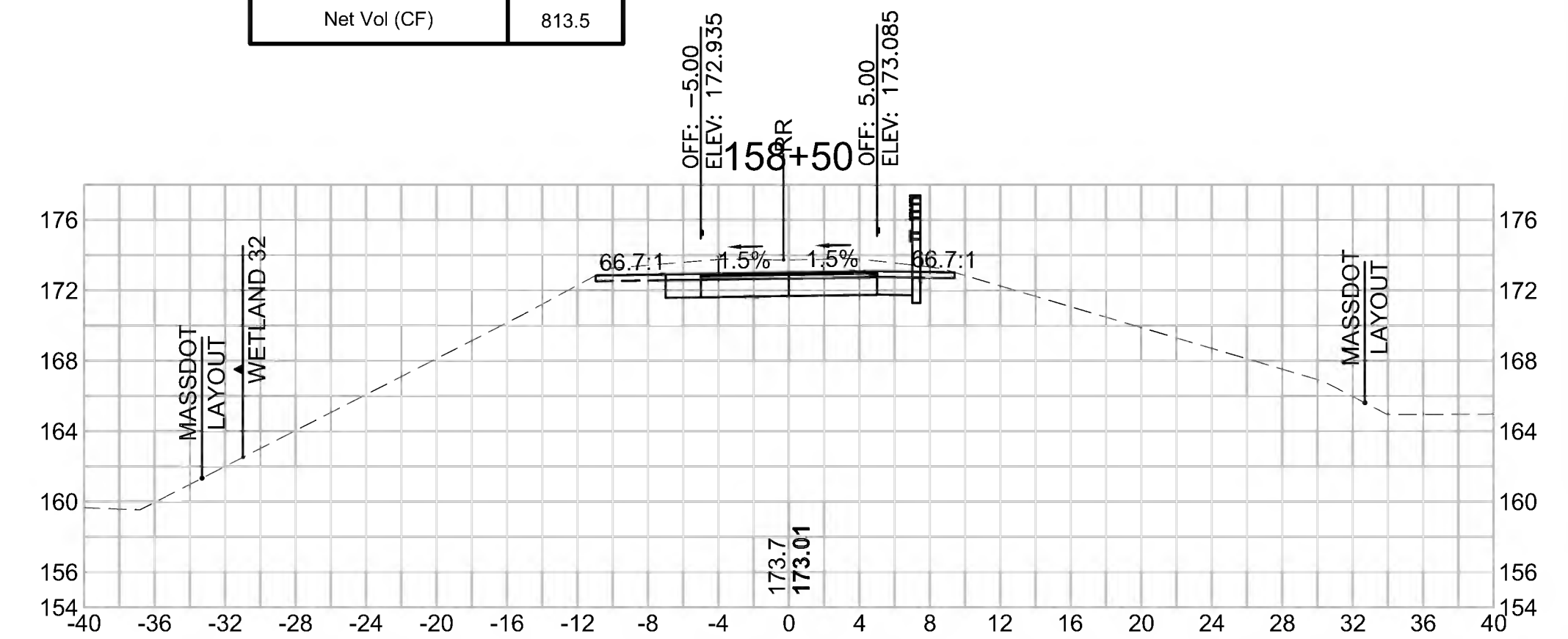

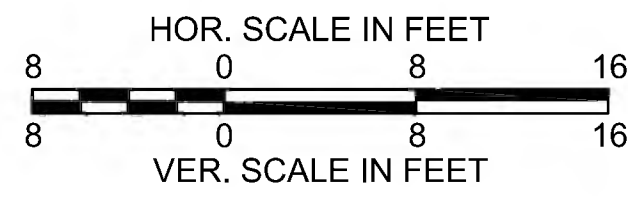

SUDBURY
 BRUCE FREEMAN RAIL TRAIL

STATE	FED. AID PROJ. NO.	SHEET NO.	TOTAL SHEETS
MA	XXX-XXX(XXX)X	259	319

PROJECT FILE NO. 608164

CROSS SECTIONS

Total Volume at Station 160+00.00

Cut Area (SF)	39.189
Fill Area (SF)	0.000
Cut Vol (CF)	72.1
Fill Vol (CF)	0.0
Cum Cut Vol (CF)	4009.1
Cum Fill Vol (CF)	2994.9
Net Vol (CF)	1014.2

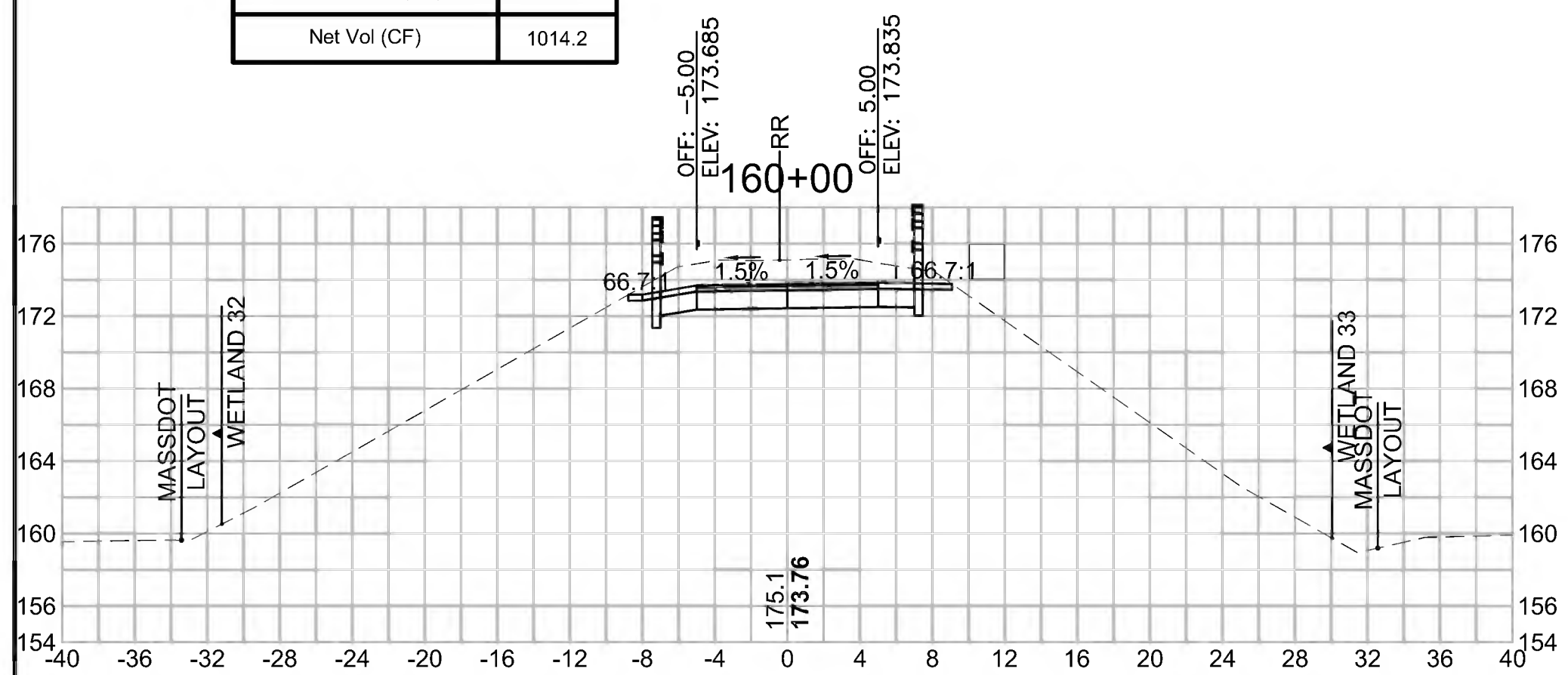

Total Volume at Station 161+00.00

Cut Area (SF)	42.411
Fill Area (SF)	0.000
Cut Vol (CF)	76.6
Fill Vol (CF)	0.0
Cum Cut Vol (CF)	4159.3
Cum Fill Vol (CF)	2994.9
Net Vol (CF)	1164.4

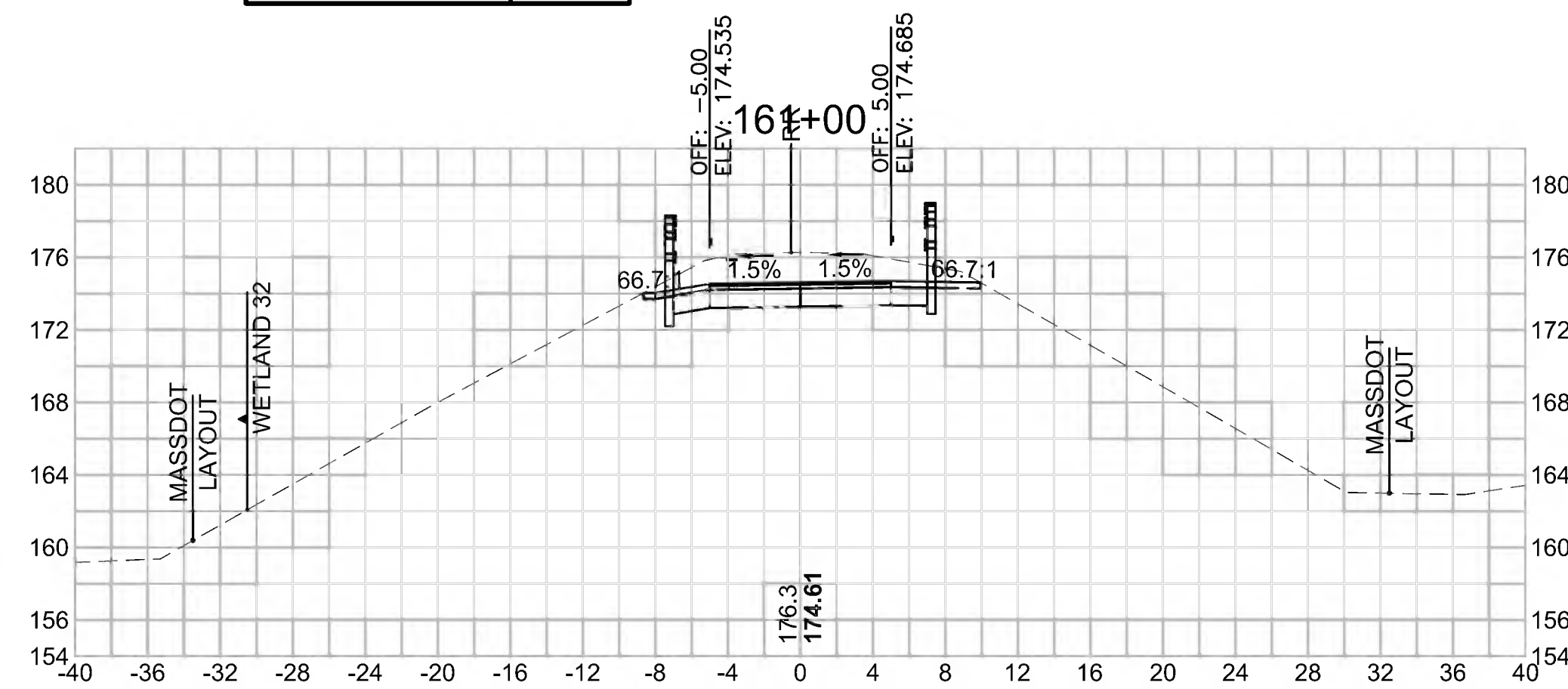

Total Volume at Station 162+00.00

Cut Area (SF)	45.471
Fill Area (SF)	0.000
Cut Vol (CF)	86.2
Fill Vol (CF)	0.0
Cum Cut Vol (CF)	4328.8
Cum Fill Vol (CF)	2994.9
Net Vol (CF)	1333.9

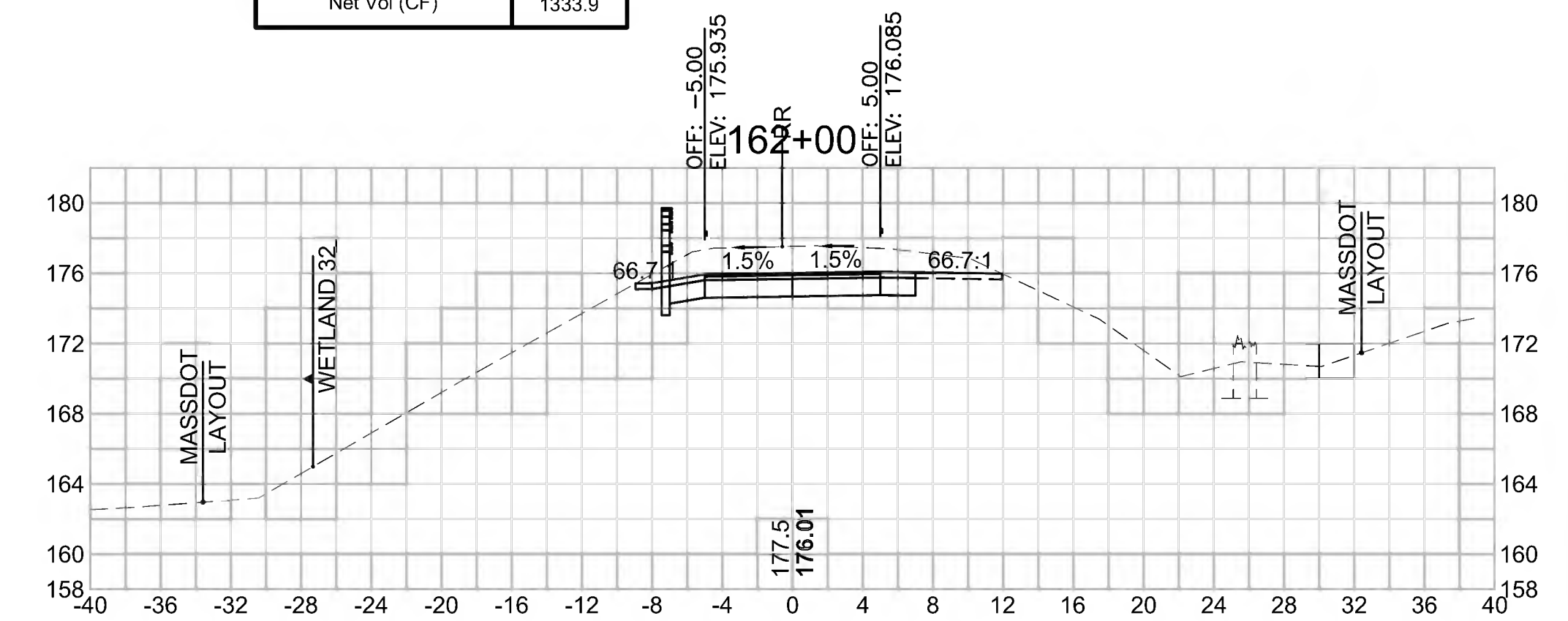

Total Volume at Station 159+50.00

Cut Area (SF)	38.715
Fill Area (SF)	0.000
Cut Vol (CF)	67.0
Fill Vol (CF)	0.0
Cum Cut Vol (CF)	3937.0
Cum Fill Vol (CF)	2994.9
Net Vol (CF)	942.1

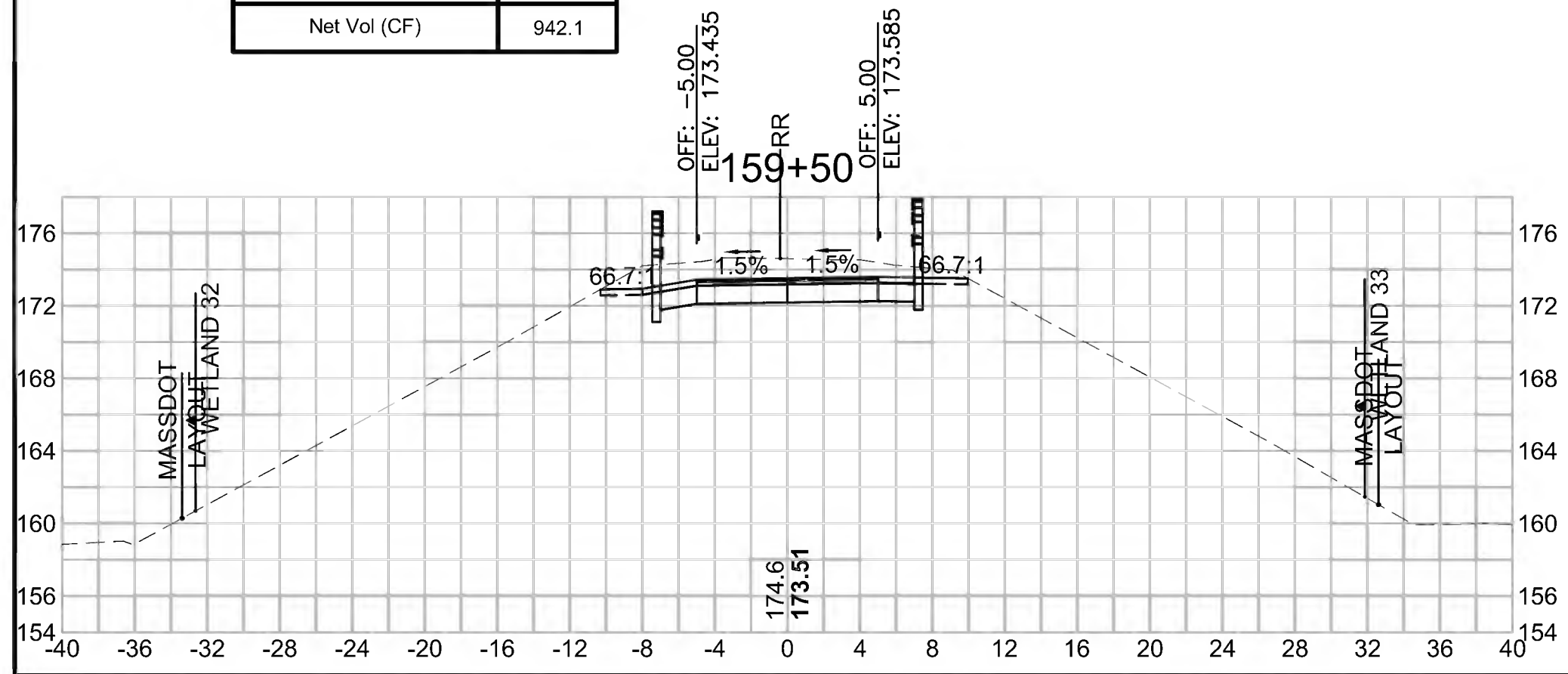

Total Volume at Station 160+50.00

Cut Area (SF)	40.277
Fill Area (SF)	0.000
Cut Vol (CF)	73.6
Fill Vol (CF)	0.0
Cum Cut Vol (CF)	4082.7
Cum Fill Vol (CF)	2994.9
Net Vol (CF)	1087.8

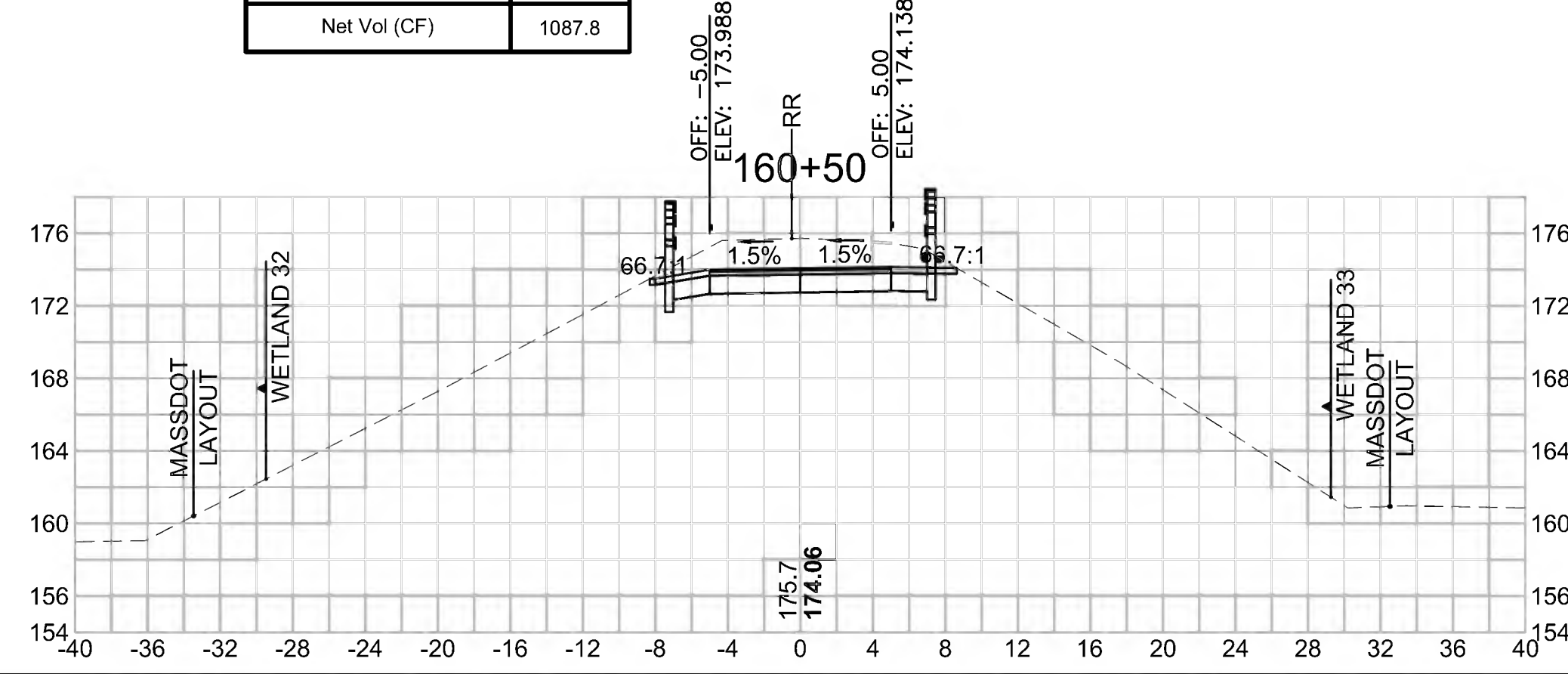

Total Volume at Station 161+50.00

Cut Area (SF)	47.585
Fill Area (SF)	0.000
Cut Vol (CF)	83.3
Fill Vol (CF)	0.0
Cum Cut Vol (CF)	4242.6
Cum Fill Vol (CF)	2994.9
Net Vol (CF)	1247.7

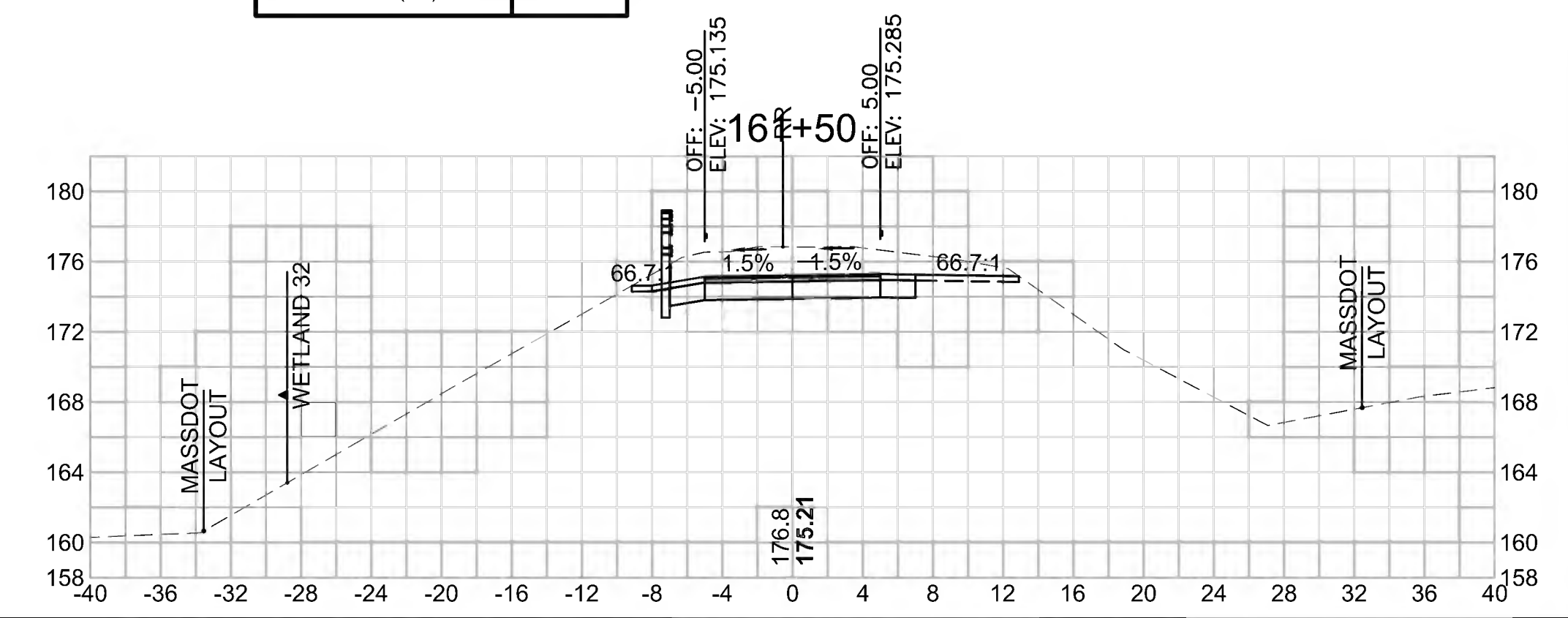

SUDBURY
BRUCE FREEMAN RAIL TRAIL

STATE	FED. AID PROJ. NO.	SHEET NO.	TOTAL SHEETS
MA	XXX-XXX(XXX)X	260	319
PROJECT FILE NO. 608164			

CROSS SECTIONS

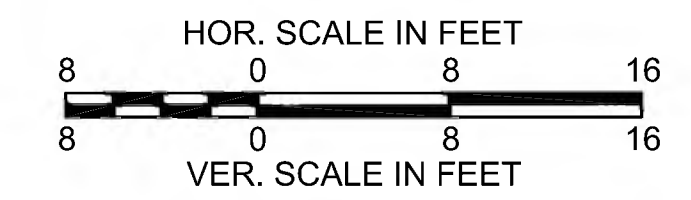

Total Volume at Station 163+50.00	
Cut Area (SF)	29.921
Fill Area (SF)	0.000
Cut Vol (CF)	53.9
Fill Vol (CF)	0.0
Cum Cut Vol (CF)	4519.6
Cum Fill Vol (CF)	2996.9
Net Vol (CF)	1522.8

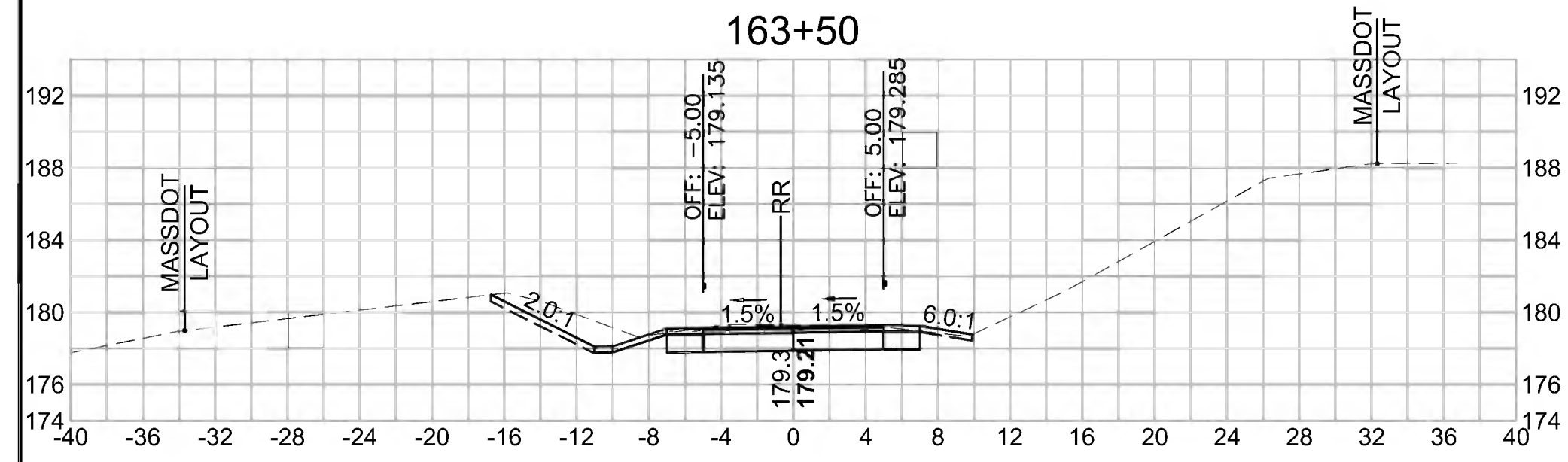

Total Volume at Station 165+00.00	
Cut Area (SF)	0.275
Fill Area (SF)	16.030
Cut Vol (CF)	2.3
Fill Vol (CF)	19.8
Cum Cut Vol (CF)	4585.6
Cum Fill Vol (CF)	3024.8
Net Vol (CF)	1560.8

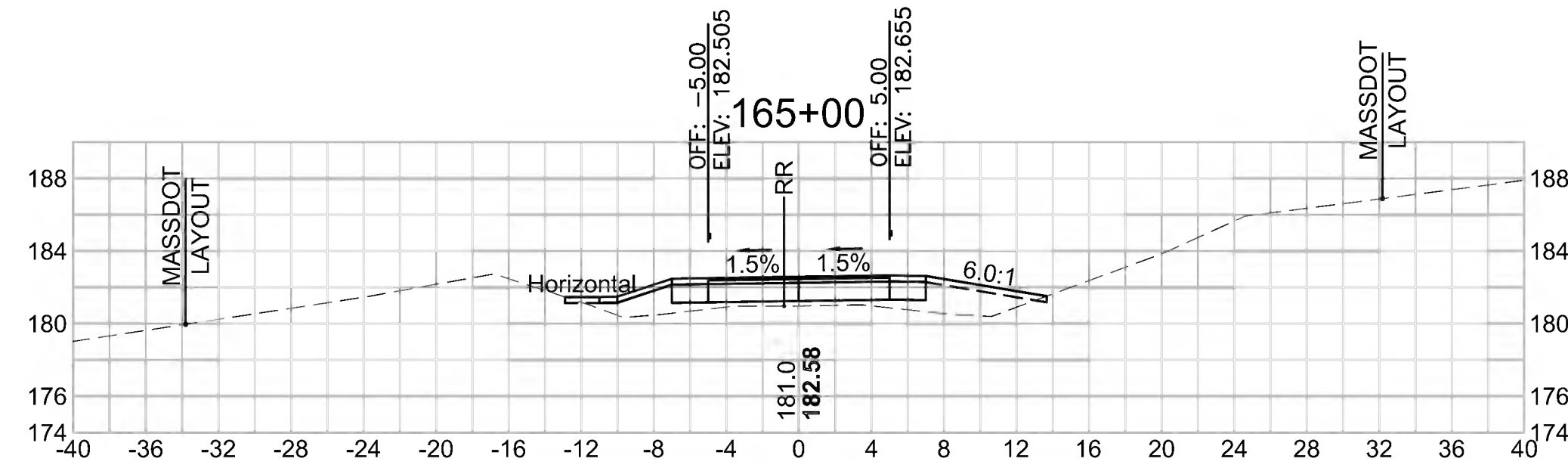

Total Volume at Station 166+50.00	
Cut Area (SF)	0.260
Fill Area (SF)	29.086
Cut Vol (CF)	0.5
Fill Vol (CF)	51.7
Cum Cut Vol (CF)	4587.0
Cum Fill Vol (CF)	3159.7
Net Vol (CF)	1427.3

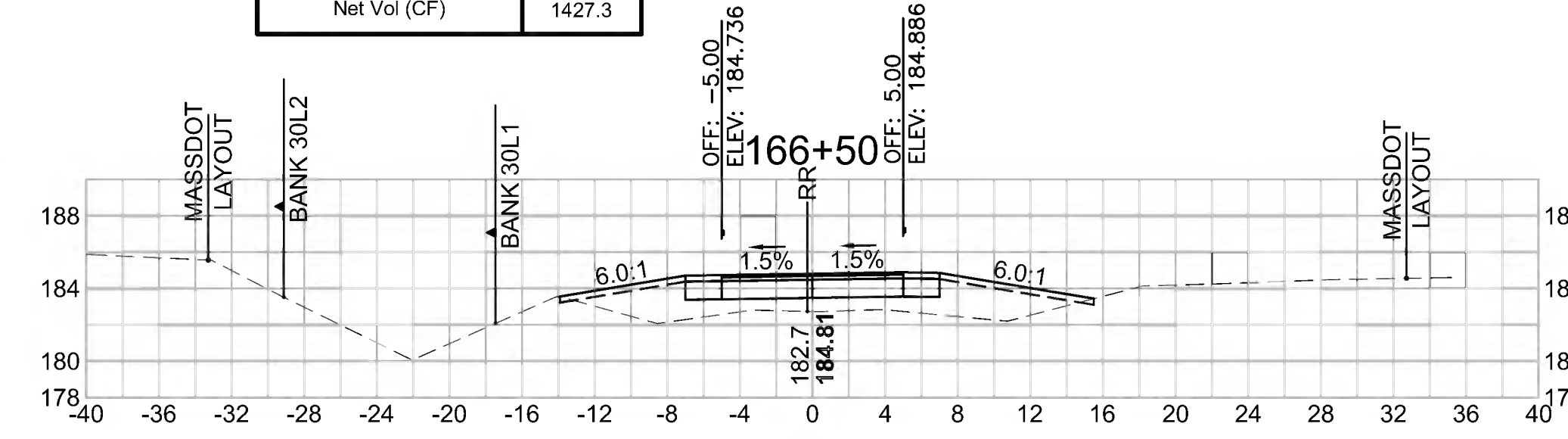

Total Volume at Station 163+00.00	
Cut Area (SF)	28.289
Fill Area (SF)	0.000
Cut Vol (CF)	60.5
Fill Vol (CF)	1.0
Cum Cut Vol (CF)	4465.7
Cum Fill Vol (CF)	2996.9
Net Vol (CF)	1468.9

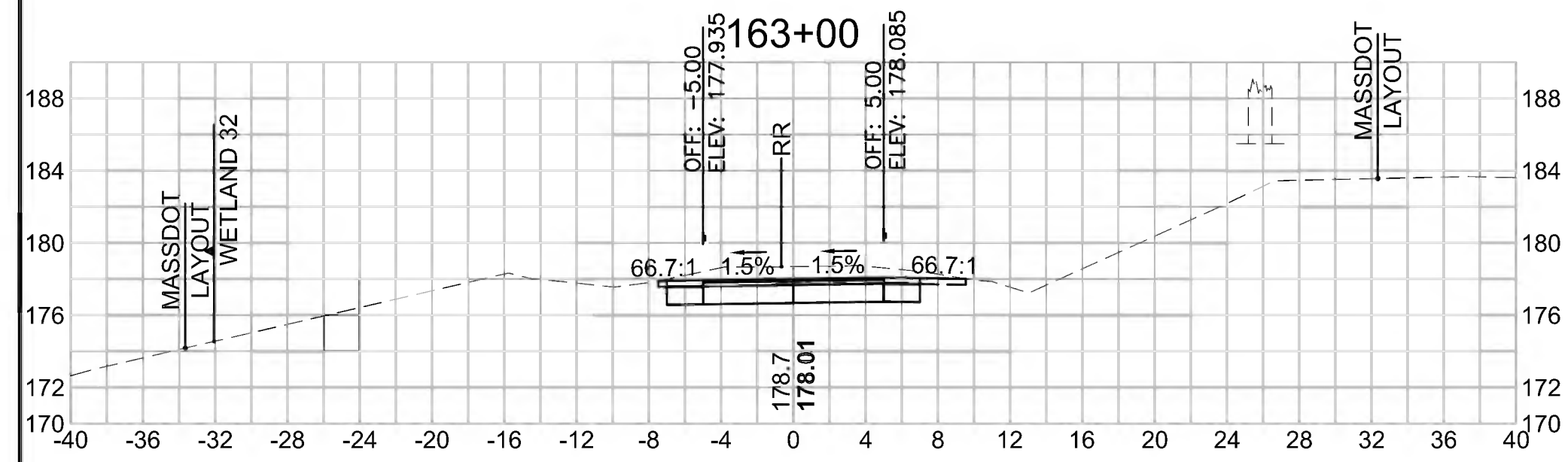

Total Volume at Station 164+50.00	
Cut Area (SF)	2.214
Fill Area (SF)	5.362
Cut Vol (CF)	19.0
Fill Vol (CF)	6.5
Cum Cut Vol (CF)	4583.3
Cum Fill Vol (CF)	3005.0
Net Vol (CF)	1578.3

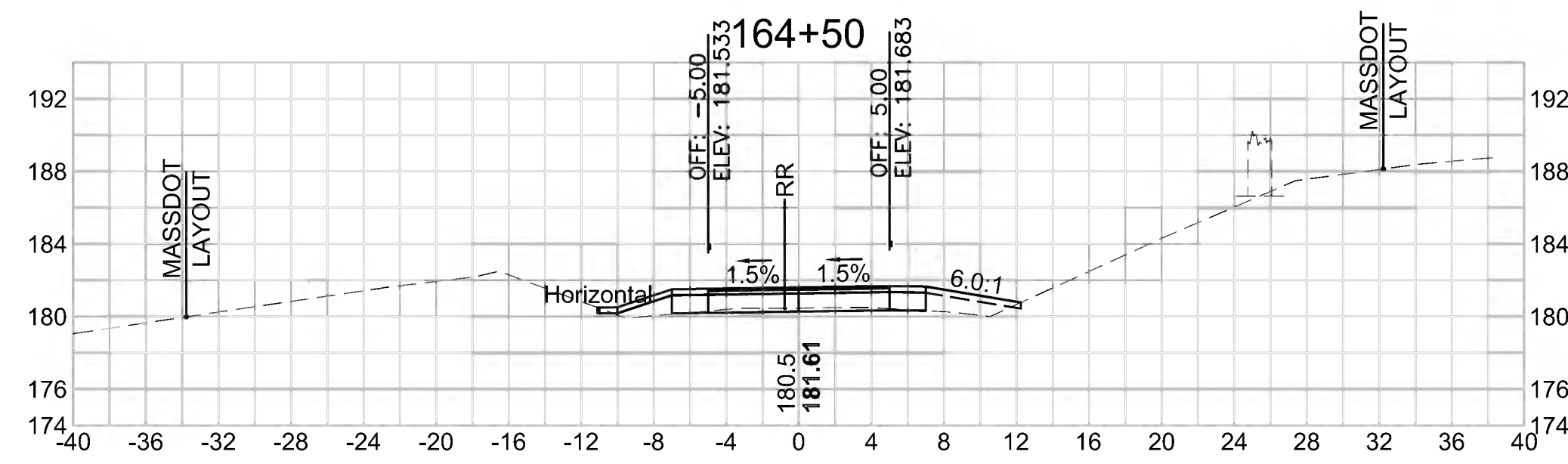

Total Volume at Station 166+00.00	
Cut Area (SF)	0.263
Fill Area (SF)	26.726
Cut Vol (CF)	0.5
Fill Vol (CF)	46.6
Cum Cut Vol (CF)	4586.5
Cum Fill Vol (CF)	3108.1
Net Vol (CF)	1478.5

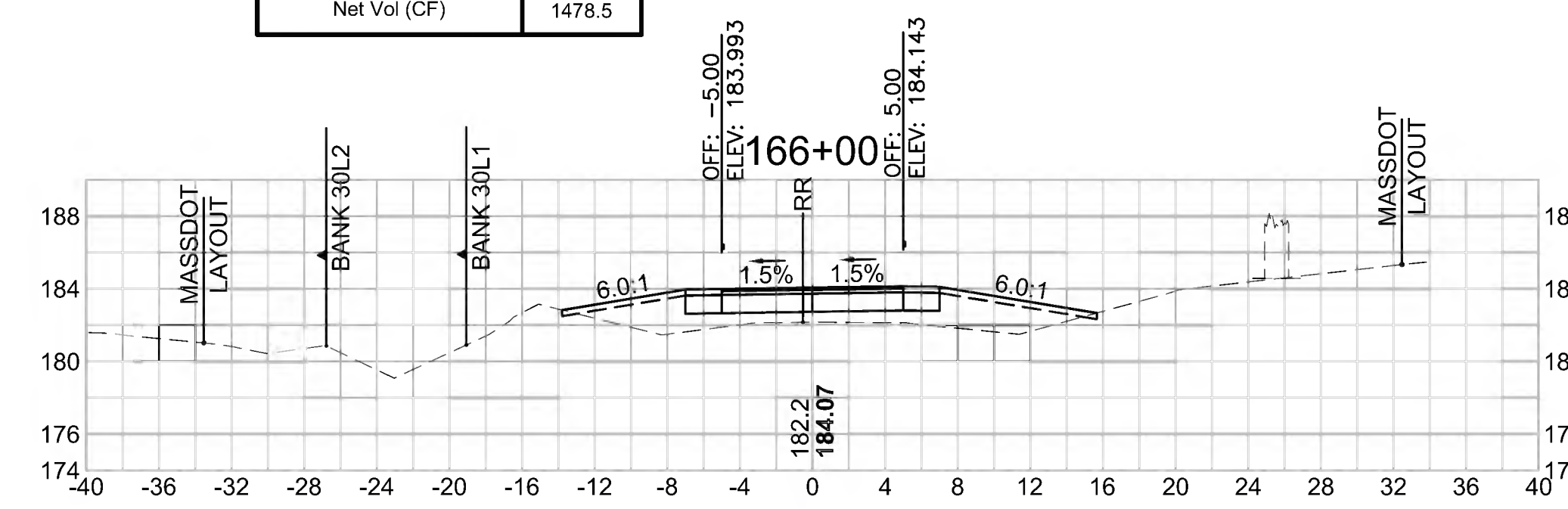

Total Volume at Station 162+50.00	
Cut Area (SF)	37.075
Fill Area (SF)	1.063
Cut Vol (CF)	76.4
Fill Vol (CF)	1.0
Cum Cut Vol (CF)	4405.2
Cum Fill Vol (CF)	2995.9
Net Vol (CF)	1409.3

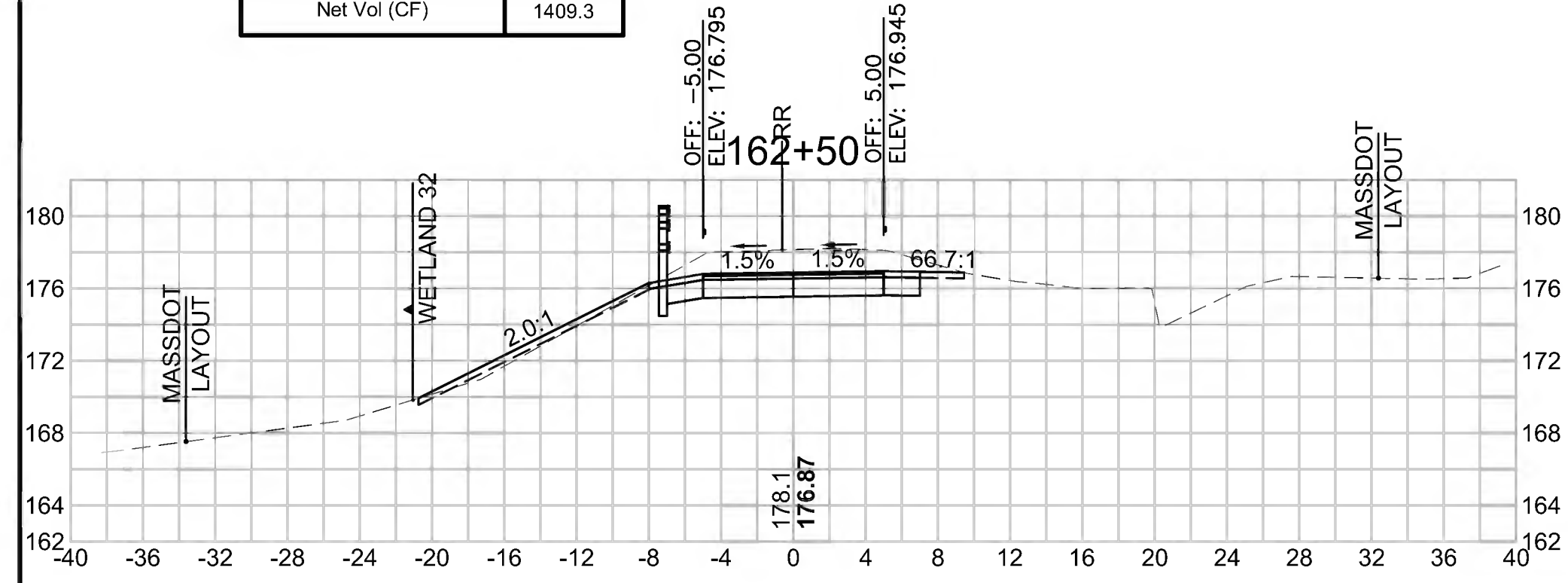

Total Volume at Station 164+00.00	
Cut Area (SF)	18.294
Fill Area (SF)	1.706
Cut Vol (CF)	44.6
Fill Vol (CF)	1.6
Cum Cut Vol (CF)	4564.3
Cum Fill Vol (CF)	2998.4
Net Vol (CF)	1565.8

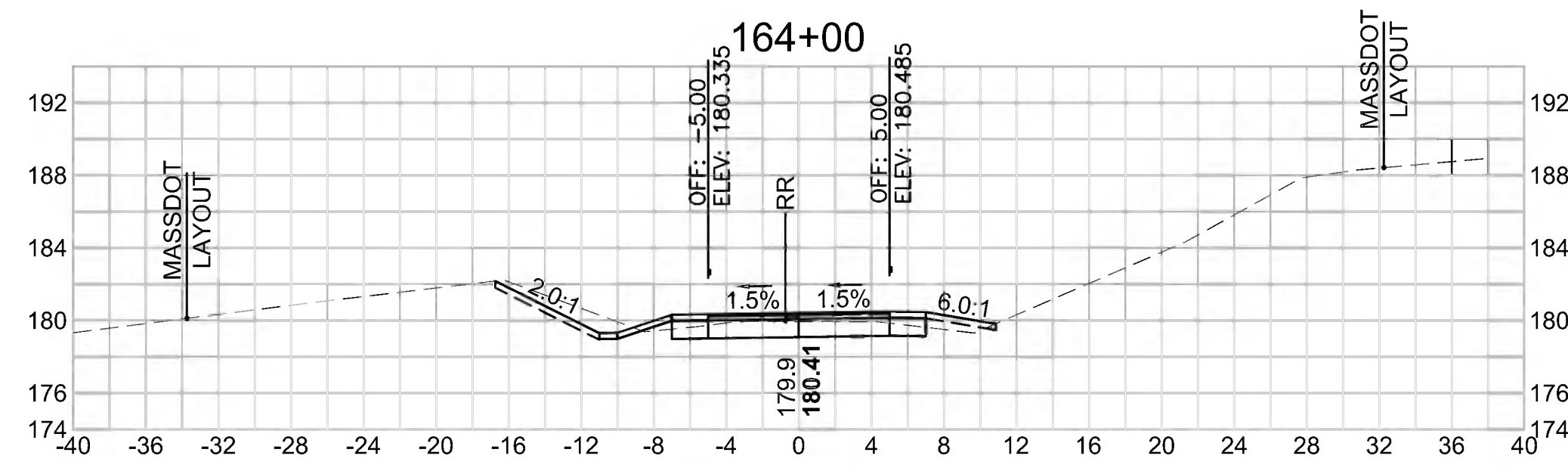

Total Volume at Station 165+50.00	
Cut Area (SF)	0.254
Fill Area (SF)	23.589
Cut Vol (CF)	0.5
Fill Vol (CF)	36.7
Cum Cut Vol (CF)	4586.0
Cum Fill Vol (CF)	3061.5
Net Vol (CF)	1524.6

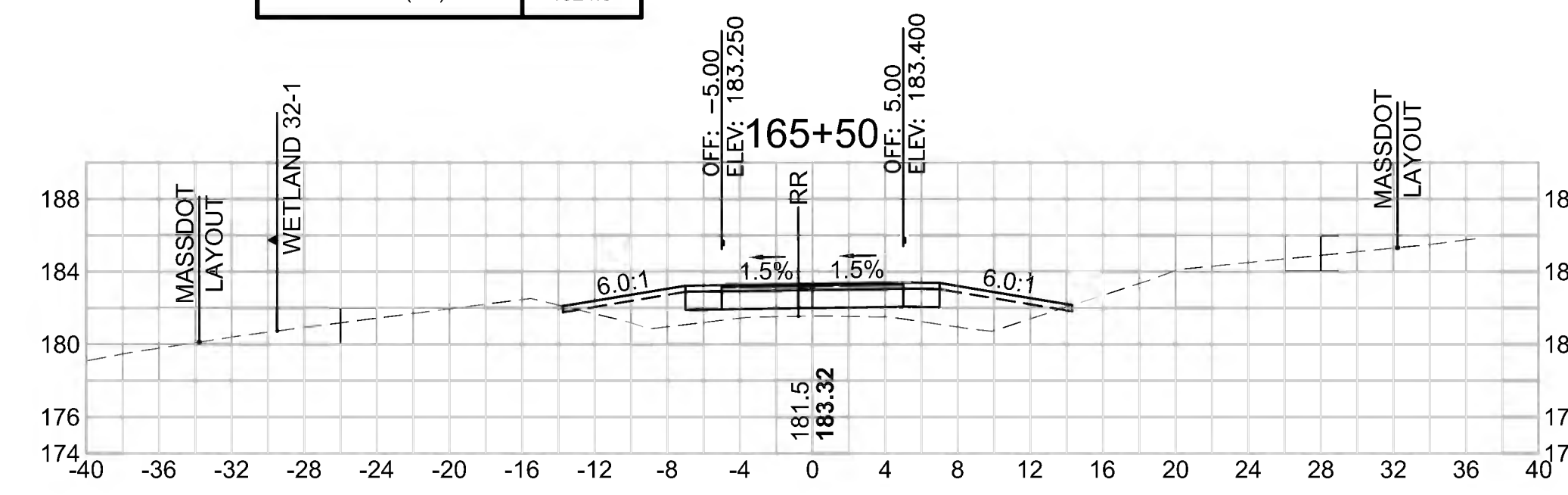

SUDBURY
BRUCE FREEMAN RAIL TRAIL

STATE	FED. AID PROJ. NO.	SHEET NO.	TOTAL SHEETS
MA	XXX-XXXX(XXX)X	261	319
PROJECT FILE NO. 608164			

CROSS SECTIONS

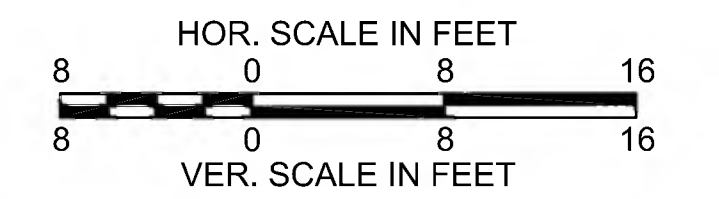

Total Volume at Station 168+00.00	
Cut Area (SF)	0.194
Fill Area (SF)	35.619
Cut Vol (CF)	0.8
Fill Vol (CF)	65.0
Cum Cut Vol (CF)	4589.0
Cum Fill Vol (CF)	3336.3
Net Vol (CF)	1252.7

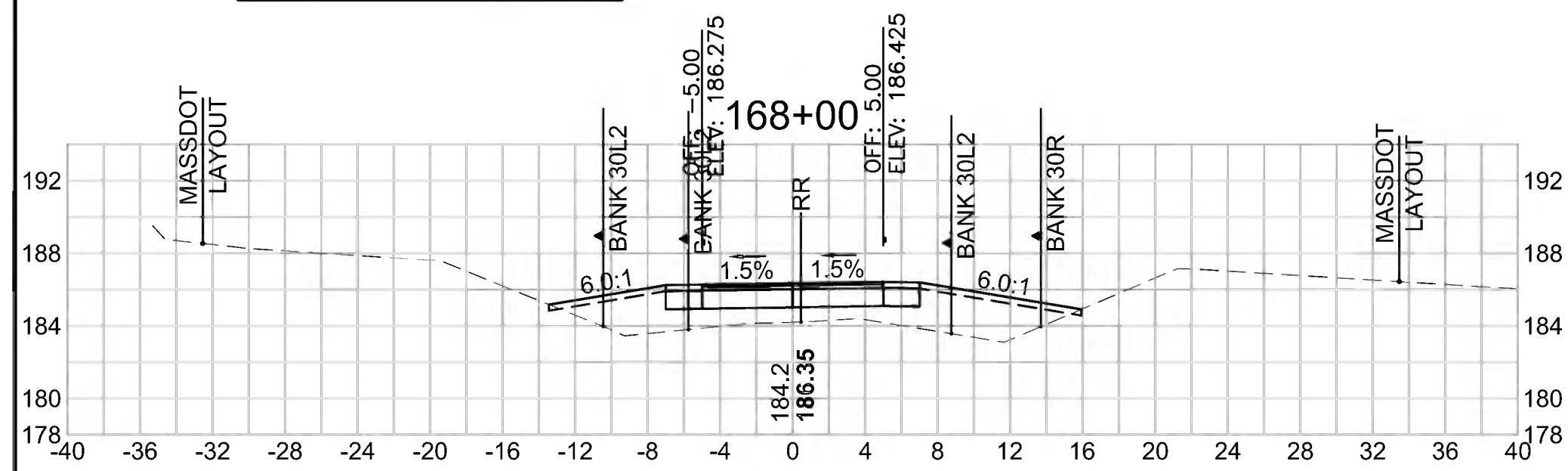

Total Volume at Station 169+50.00	
Cut Area (SF)	0.403
Fill Area (SF)	8.035
Cut Vol (CF)	0.5
Fill Vol (CF)	21.7
Cum Cut Vol (CF)	4590.3
Cum Fill Vol (CF)	3461.8
Net Vol (CF)	1128.5

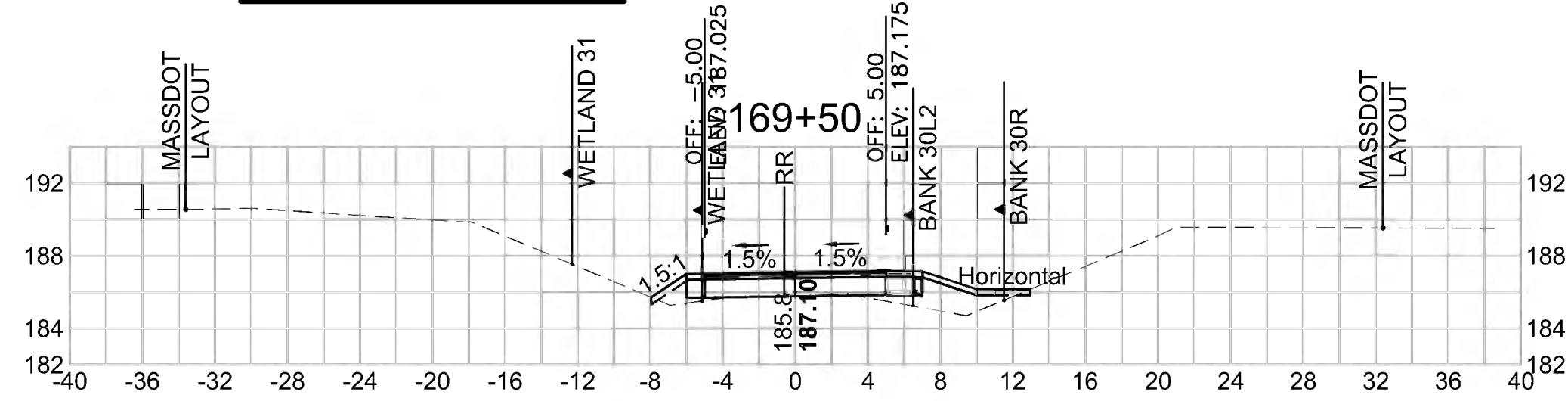

Total Volume at Station 171+00.00	
Cut Area (SF)	18.314
Fill Area (SF)	1.100
Cut Vol (CF)	29.6
Fill Vol (CF)	4.1
Cum Cut Vol (CF)	4651.7
Cum Fill Vol (CF)	3485.8
Net Vol (CF)	1165.8

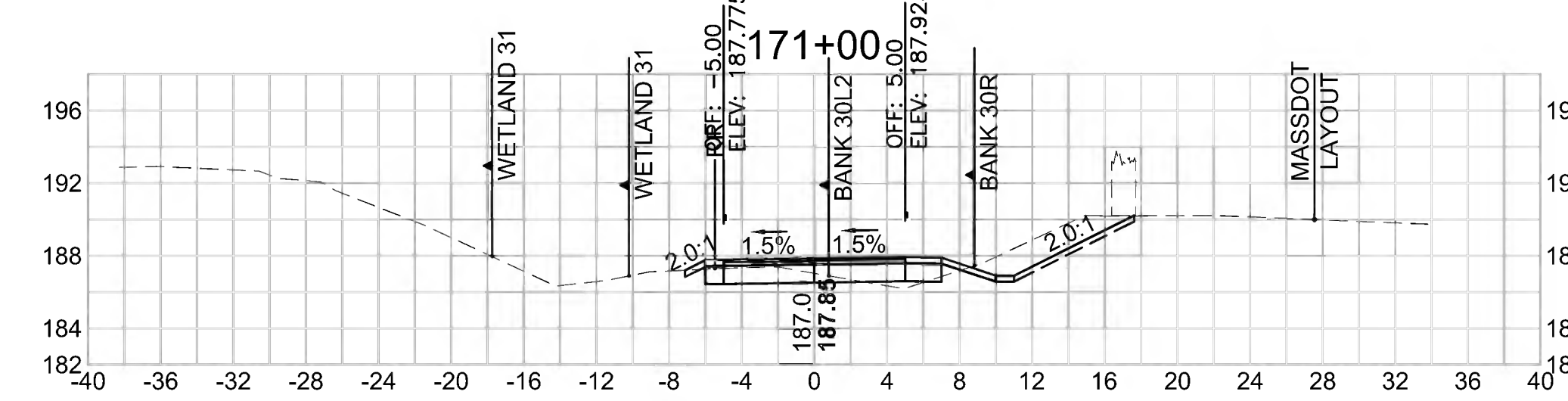

Total Volume at Station 167+50.00	
Cut Area (SF)	0.684
Fill Area (SF)	34.621
Cut Vol (CF)	0.8
Fill Vol (CF)	58.3
Cum Cut Vol (CF)	4588.2
Cum Fill Vol (CF)	3271.3
Net Vol (CF)	1316.9

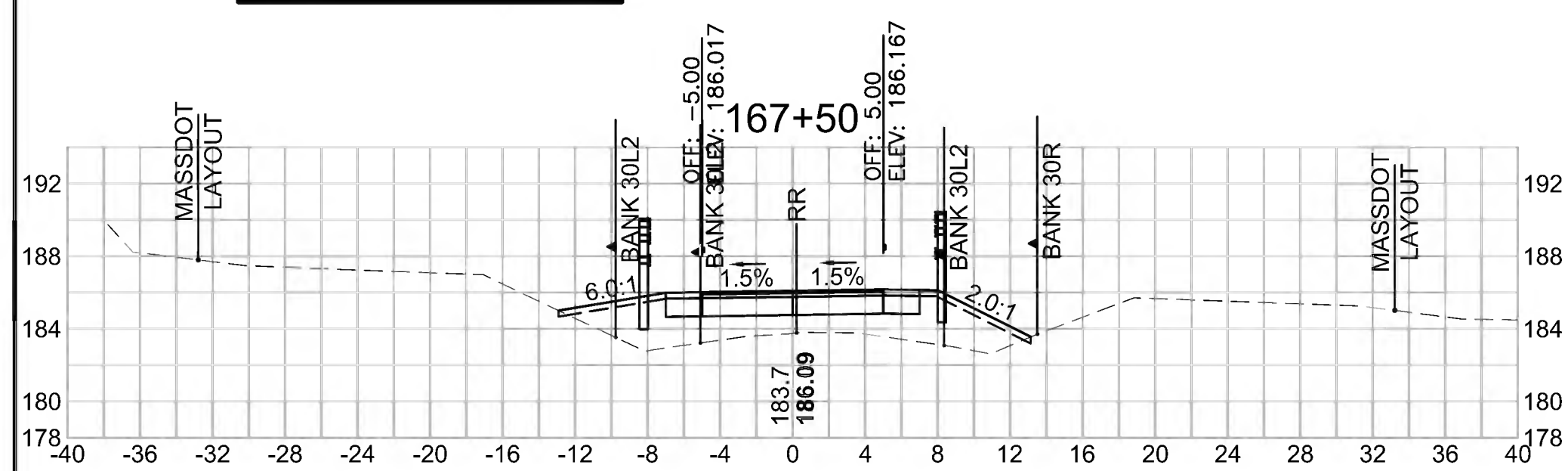

Total Volume at Station 169+00.00	
Cut Area (SF)	0.176
Fill Area (SF)	15.367
Cut Vol (CF)	0.3
Fill Vol (CF)	42.5
Cum Cut Vol (CF)	4589.7
Cum Fill Vol (CF)	3440.1
Net Vol (CF)	1149.6

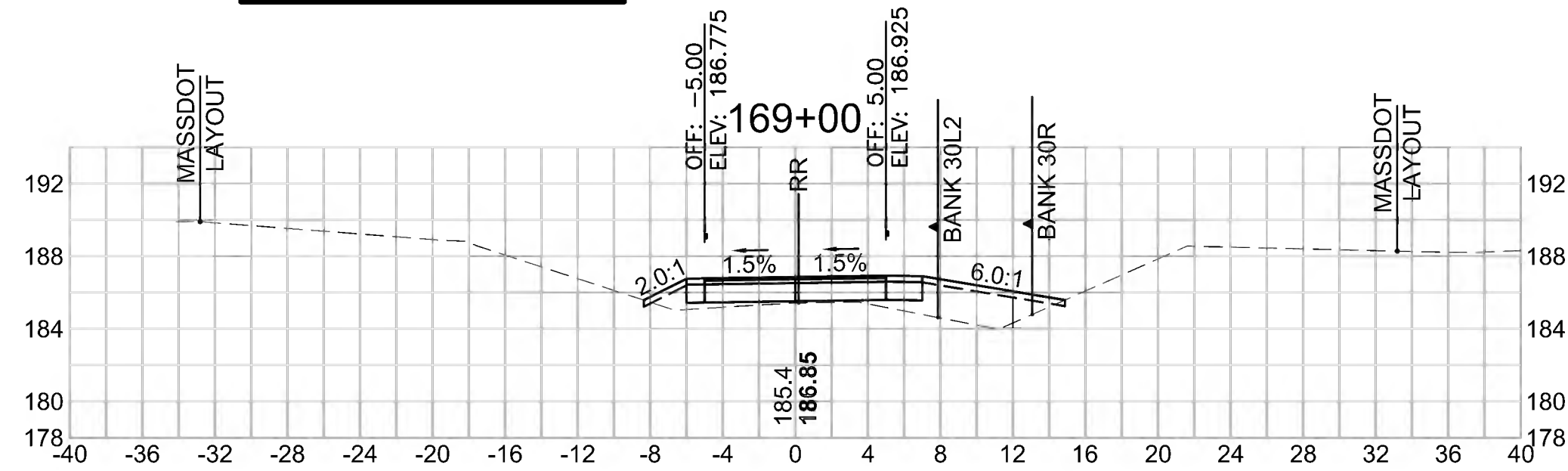

Total Volume at Station 170+50.00	
Cut Area (SF)	13.656
Fill Area (SF)	3.305
Cut Vol (CF)	22.0
Fill Vol (CF)	7.8
Cum Cut Vol (CF)	4622.1
Cum Fill Vol (CF)	3481.7
Net Vol (CF)	1140.3

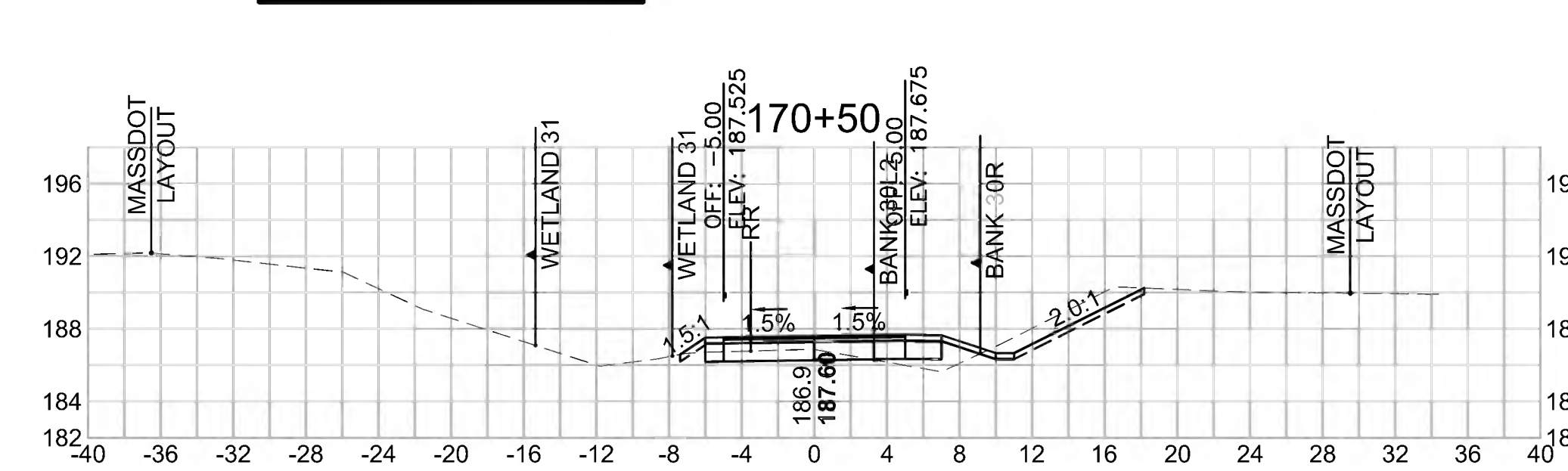

Total Volume at Station 167+00.00	
Cut Area (SF)	0.182
Fill Area (SF)	28.381
Cut Vol (CF)	0.4
Fill Vol (CF)	53.2
Cum Cut Vol (CF)	4587.4
Cum Fill Vol (CF)	3212.9
Net Vol (CF)	1374.5

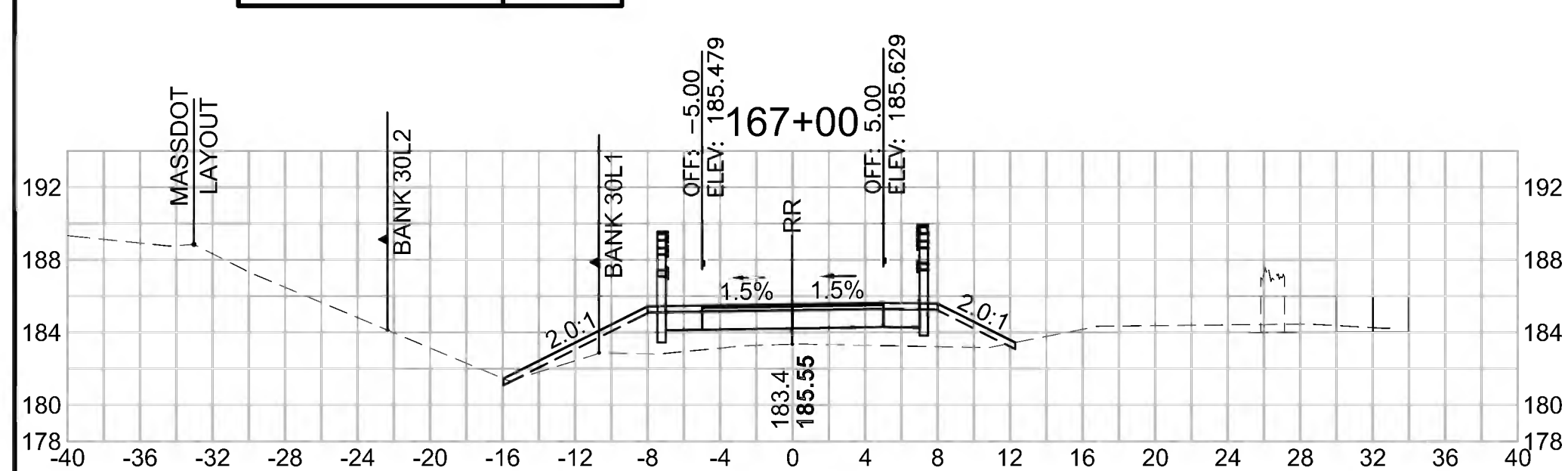

Total Volume at Station 168+50.00	
Cut Area (SF)	0.194
Fill Area (SF)	30.567
Cut Vol (CF)	0.4
Fill Vol (CF)	61.3
Cum Cut Vol (CF)	4589.4
Cum Fill Vol (CF)	3397.6
Net Vol (CF)	1191.8

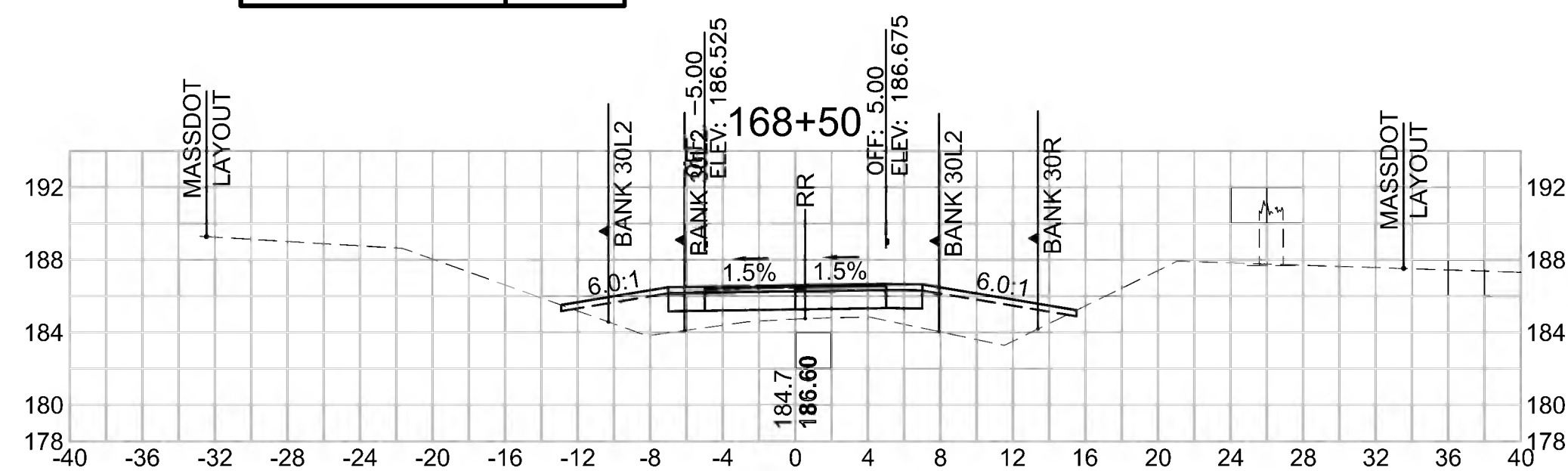

Total Volume at Station 170+00.00	
Cut Area (SF)	10.138
Fill Area (SF)	5.098
Cut Vol (CF)	9.8
Fill Vol (CF)	12.2
Cum Cut Vol (CF)	4600.0
Cum Fill Vol (CF)	3474.0
Net Vol (CF)	1126.1

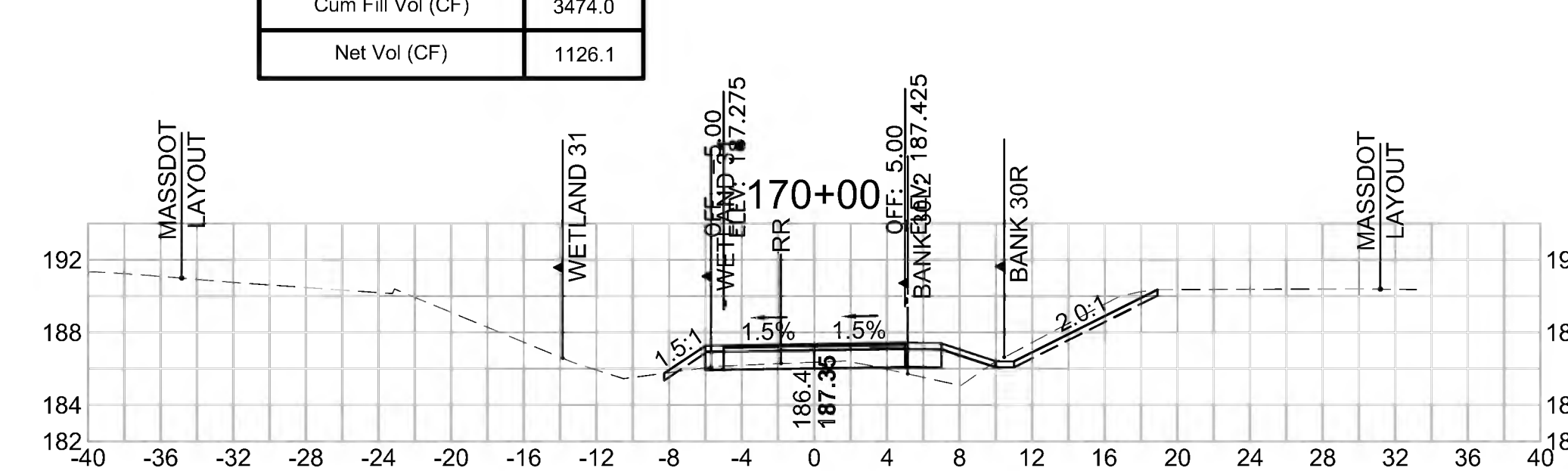

SUDBURY
BRUCE FREEMAN RAIL TRAIL

STATE	FED. AID PROJ. NO.	SHEET NO.	TOTAL SHEETS
MA	XXX-XXXX(XXX)X	262	319
PROJECT FILE NO. 608164			

CROSS SECTIONS

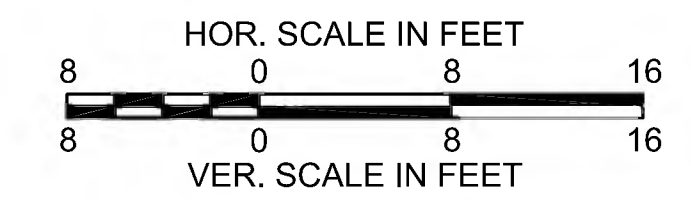

Total Volume at Station 172+50.00

Cut Area (SF)	14.444
Fill Area (SF)	1.856
Cut Vol (CF)	28.7
Fill Vol (CF)	2.4
Cum Cut Vol (CF)	4748.8
Cum Fill Vol (CF)	3491.8
Net Vol (CF)	1257.0

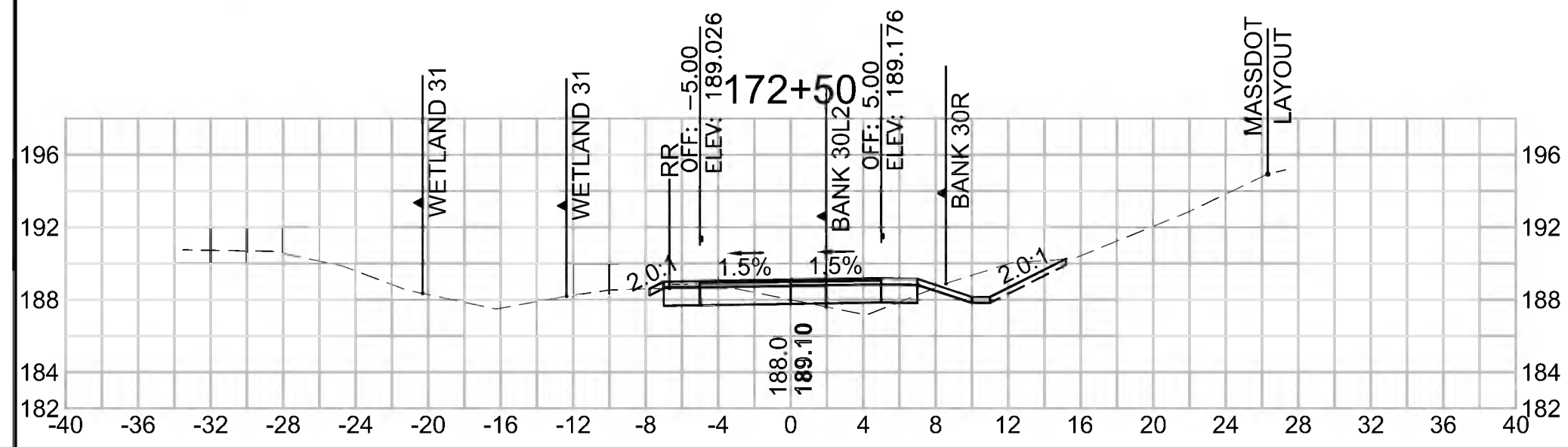

Total Volume at Station 174+00.00

Cut Area (SF)	0.192
Fill Area (SF)	14.826
Cut Vol (CF)	2.1
Fill Vol (CF)	23.5
Cum Cut Vol (CF)	4778.9
Cum Fill Vol (CF)	3537.5
Net Vol (CF)	1241.5

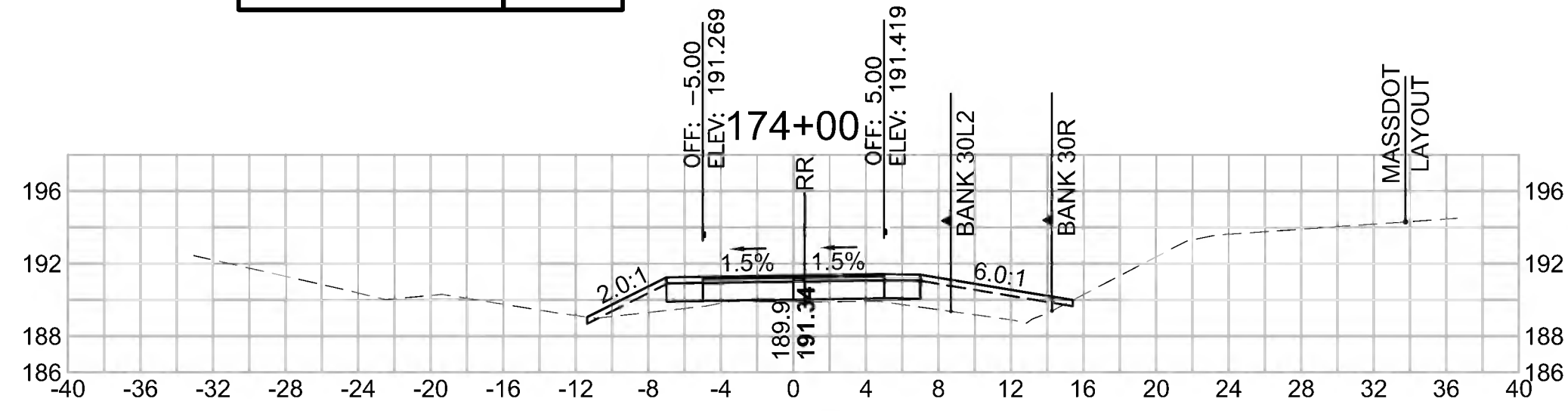

Total Volume at Station 175+50.00

Cut Area (SF)	62.333
Fill Area (SF)	0.000
Cut Vol (CF)	78.3
Fill Vol (CF)	0.0
Cum Cut Vol (CF)	4882.8
Cum Fill Vol (CF)	3556.4
Net Vol (CF)	1326.4

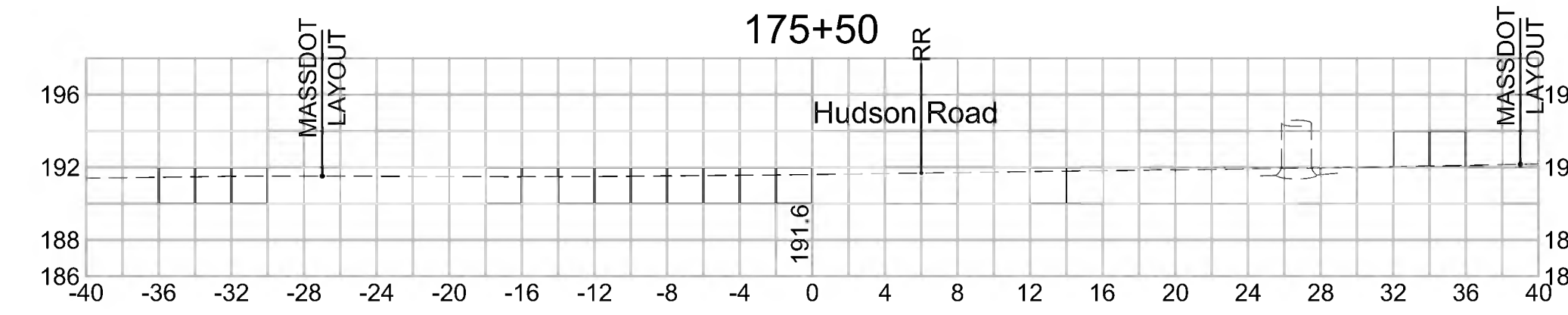

Total Volume at Station 172+00.00

Cut Area (SF)	16.508
Fill Area (SF)	0.728
Cut Vol (CF)	33.4
Fill Vol (CF)	1.6
Cum Cut Vol (CF)	4720.2
Cum Fill Vol (CF)	3489.4
Net Vol (CF)	1230.8

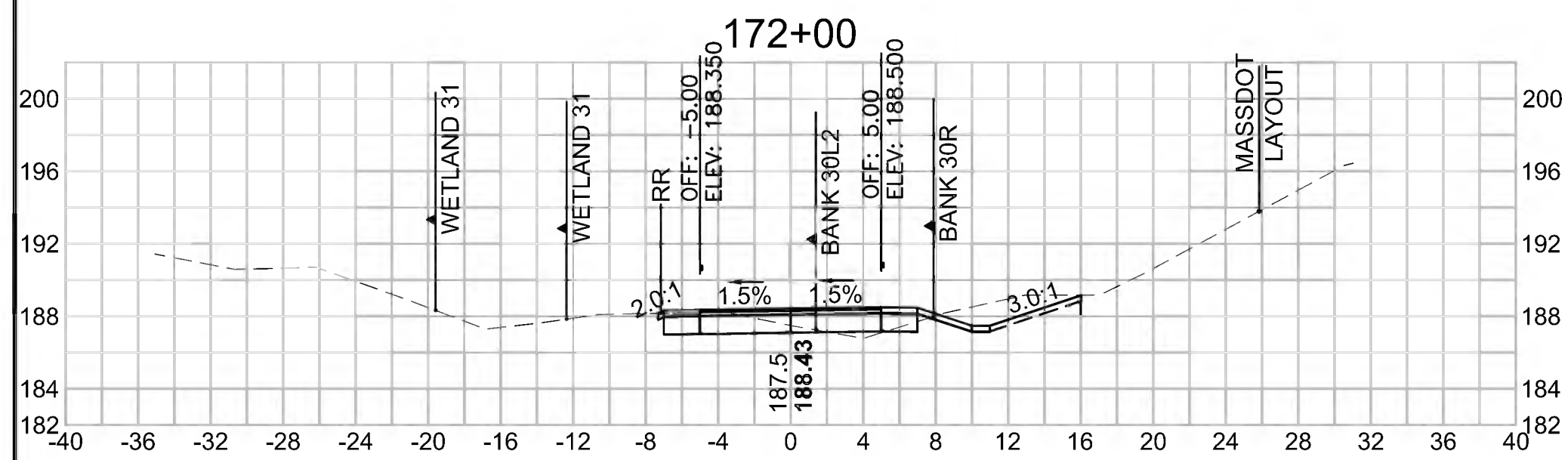

Total Volume at Station 173+50.00

Cut Area (SF)	2.056
Fill Area (SF)	10.538
Cut Vol (CF)	8.3
Fill Vol (CF)	15.1
Cum Cut Vol (CF)	4776.9
Cum Fill Vol (CF)	3514.0
Net Vol (CF)	1262.9

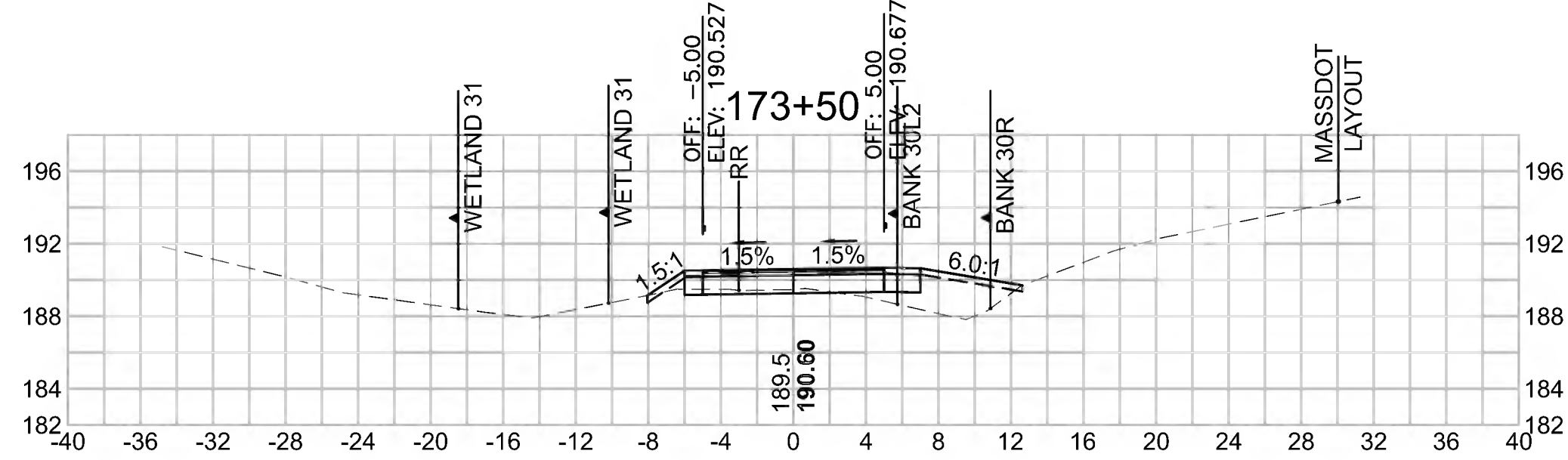

Total Volume at Station 175+00.00

Cut Area (SF)	22.279
Fill Area (SF)	0.000
Cut Vol (CF)	23.0
Fill Vol (CF)	2.6
Cum Cut Vol (CF)	4804.5
Cum Fill Vol (CF)	3556.4
Net Vol (CF)	1248.1

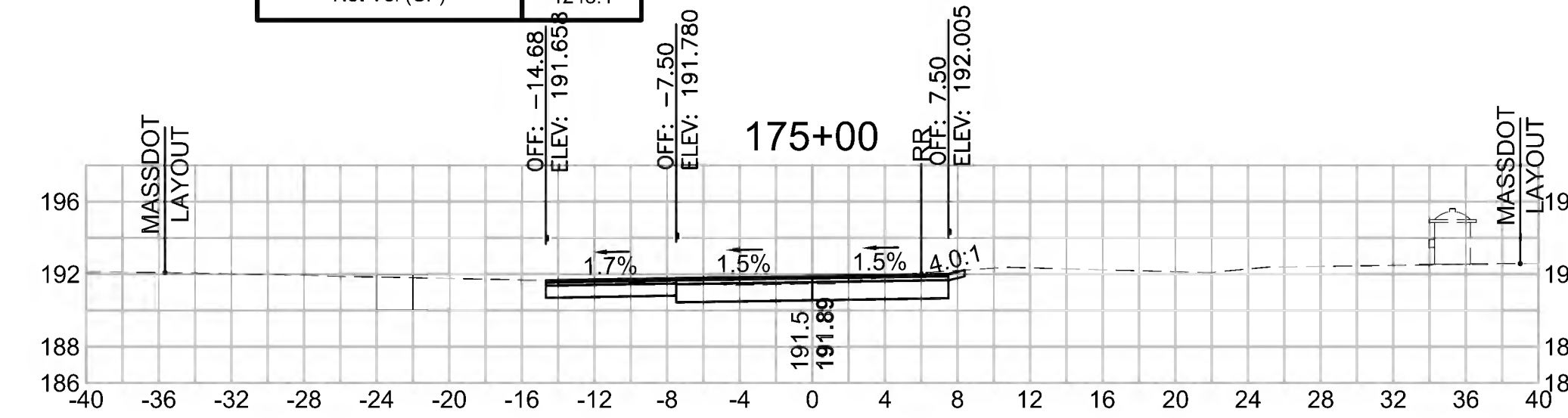

Total Volume at Station 171+50.00

Cut Area (SF)	19.590
Fill Area (SF)	1.028
Cut Vol (CF)	35.1
Fill Vol (CF)	2.0
Cum Cut Vol (CF)	4686.8
Cum Fill Vol (CF)	3487.8
Net Vol (CF)	1199.0

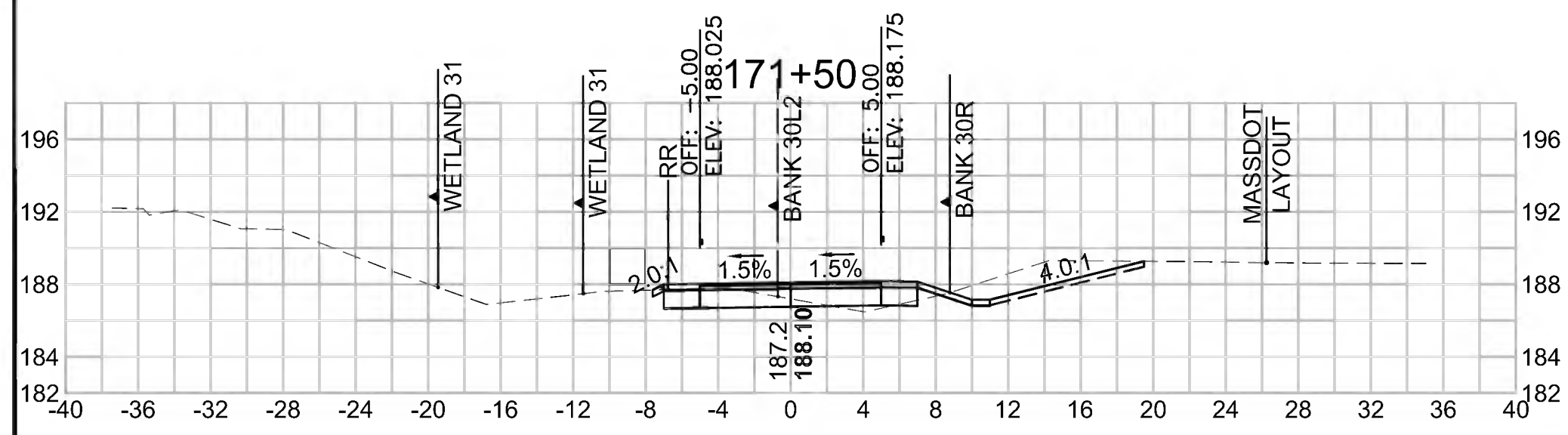

Total Volume at Station 173+00.00

Cut Area (SF)	6.878
Fill Area (SF)	5.789
Cut Vol (CF)	19.7
Fill Vol (CF)	7.1
Cum Cut Vol (CF)	4768.6
Cum Fill Vol (CF)	3498.9
Net Vol (CF)	1269.7

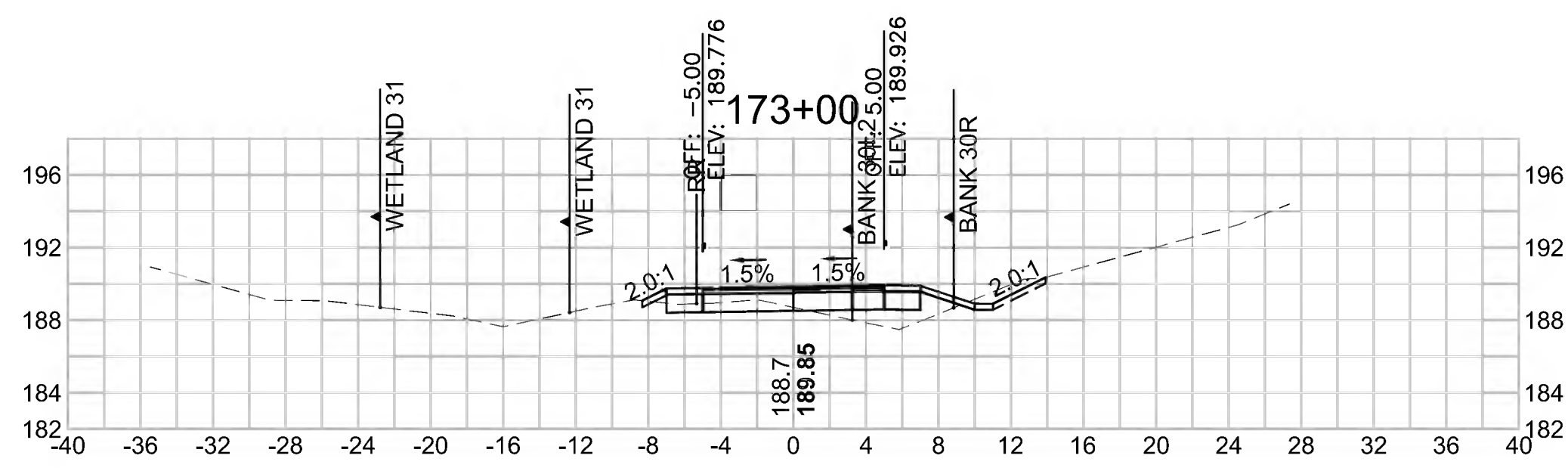

Total Volume at Station 174+50.00

Cut Area (SF)	2.543
Fill Area (SF)	2.778
Cut Vol (CF)	2.5
Fill Vol (CF)	16.3
Cum Cut Vol (CF)	4781.5
Cum Fill Vol (CF)	3553.8
Net Vol (CF)	1227.7

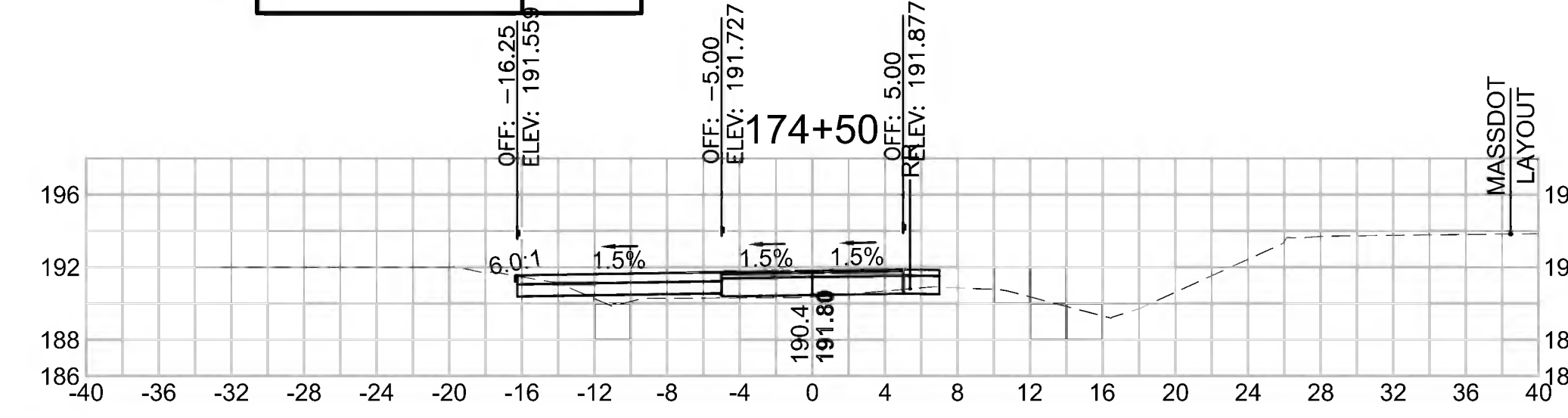

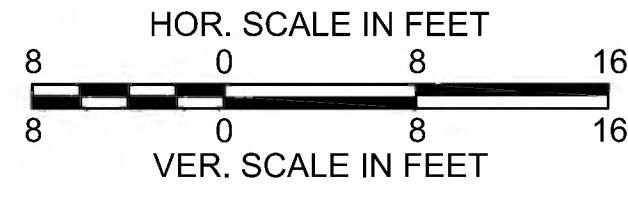

SUDBURY
 BRUCE FREEMAN RAIL TRAIL

STATE	FED. AID PROJ. NO.	SHEET NO.	TOTAL SHEETS
MA	XXX-XXX(XXX)X	263	319

PROJECT FILE NO. 608164

CROSS SECTIONS

Total Volume at Station 177+00.00

Cut Area (SF)	19.799
Fill Area (SF)	5.793
Cut Vol (CF)	47.2
Fill Vol (CF)	6.1
Cum Cut Vol (CF)	5094.1
Cum Fill Vol (CF)	3563.4
Net Vol (CF)	1530.8

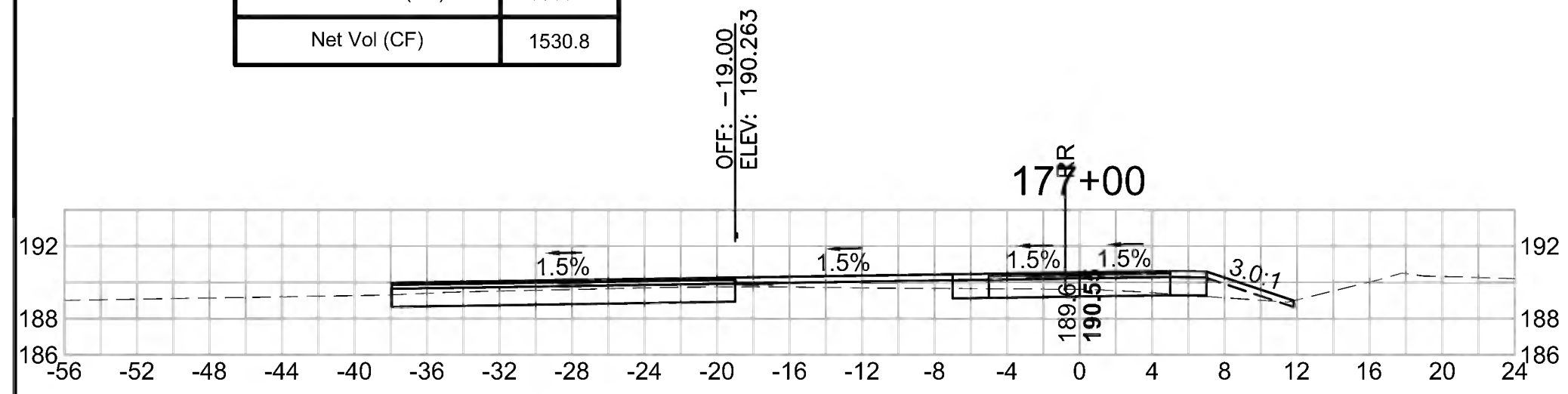

Total Volume at Station 178+50.00

Cut Area (SF)	3.447
Fill Area (SF)	7.054
Cut Vol (CF)	7.8
Fill Vol (CF)	11.3
Cum Cut Vol (CF)	5134.5
Cum Fill Vol (CF)	3593.0
Net Vol (CF)	1541.5

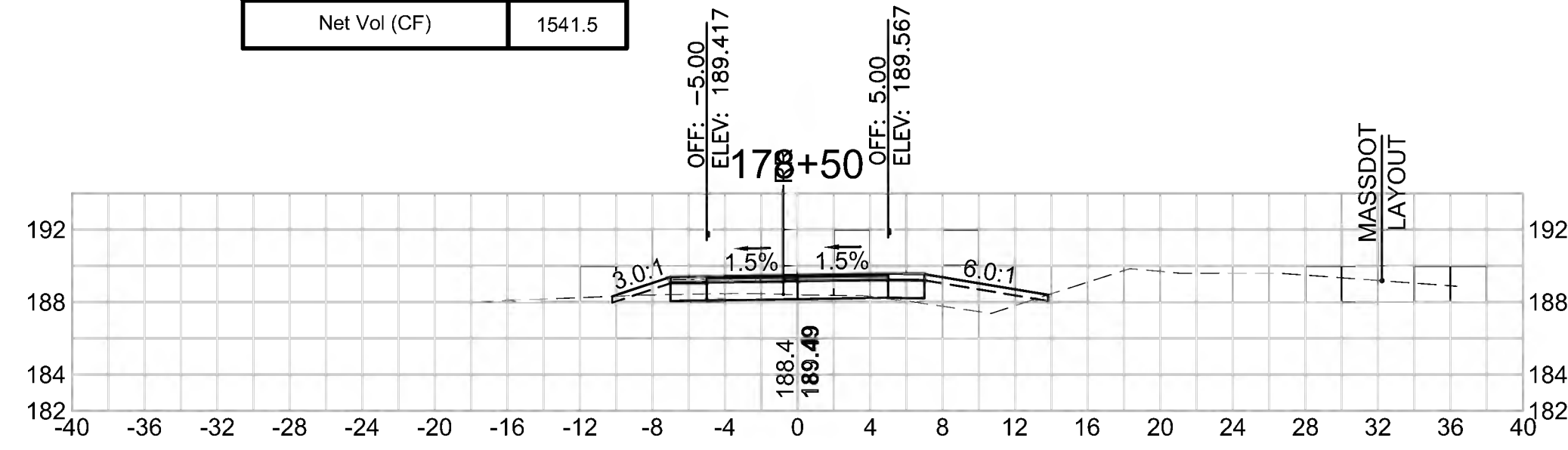

Total Volume at Station 180+00.00

Cut Area (SF)	0.426
Fill Area (SF)	16.145
Cut Vol (CF)	1.9
Fill Vol (CF)	21.0
Cum Cut Vol (CF)	5146.1
Cum Fill Vol (CF)	3643.1
Net Vol (CF)	1503.0

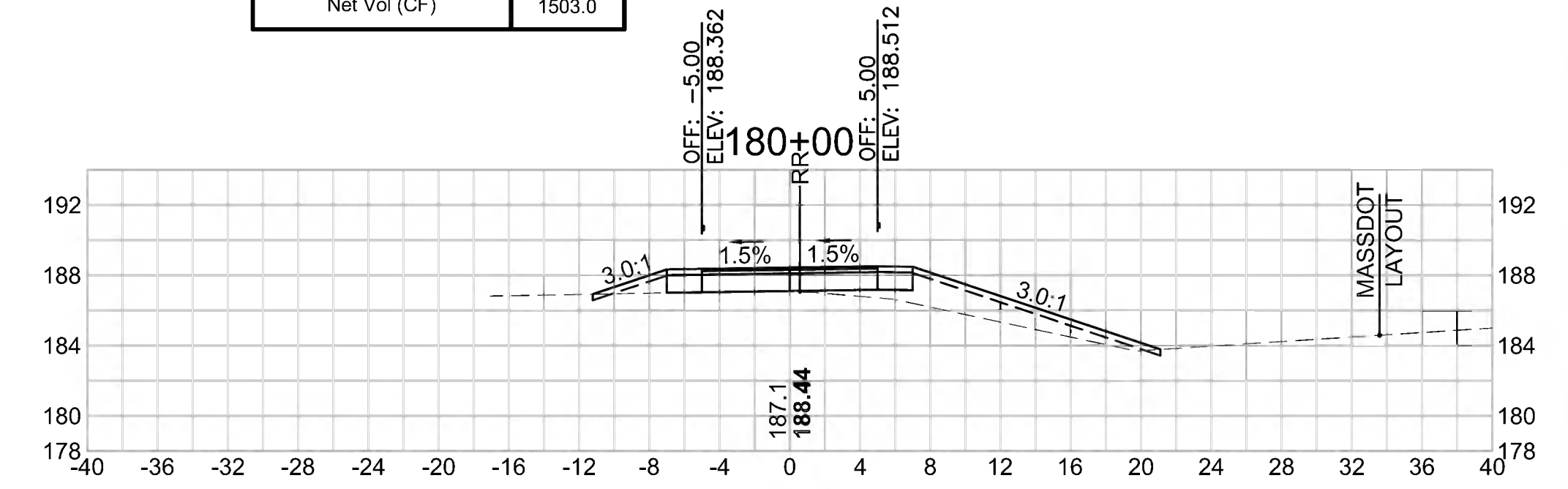

Total Volume at Station 176+50.00

Cut Area (SF)	31.157
Fill Area (SF)	0.745
Cut Vol (CF)	67.6
Fill Vol (CF)	0.8
Cum Cut Vol (CF)	5047.0
Cum Fill Vol (CF)	3557.3
Net Vol (CF)	1489.6

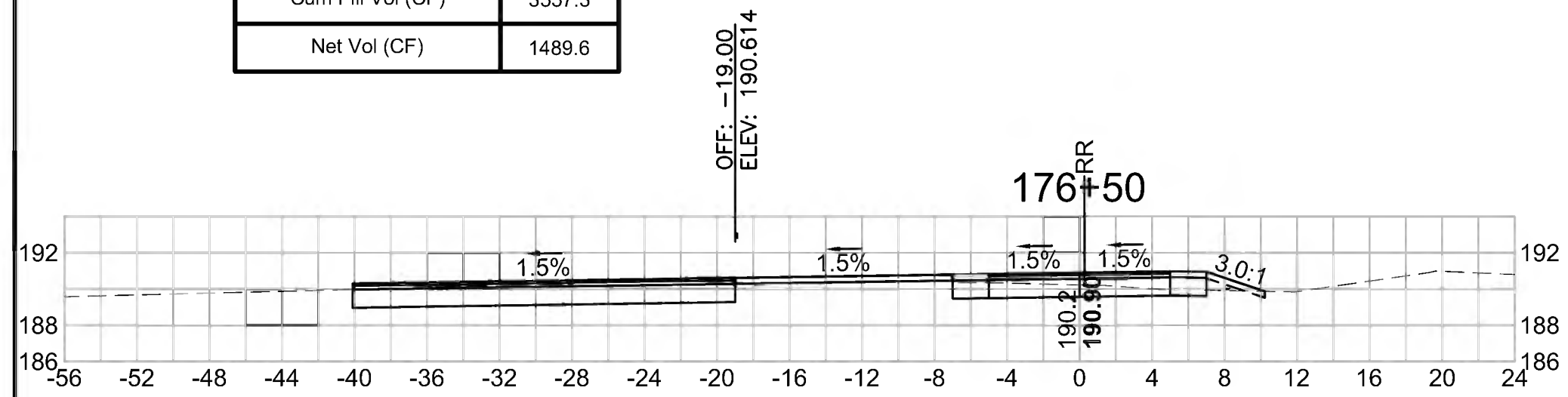

Total Volume at Station 178+00.00

Cut Area (SF)	5.000
Fill Area (SF)	5.132
Cut Vol (CF)	9.4
Fill Vol (CF)	8.9
Cum Cut Vol (CF)	5126.6
Cum Fill Vol (CF)	3581.7
Net Vol (CF)	1544.9

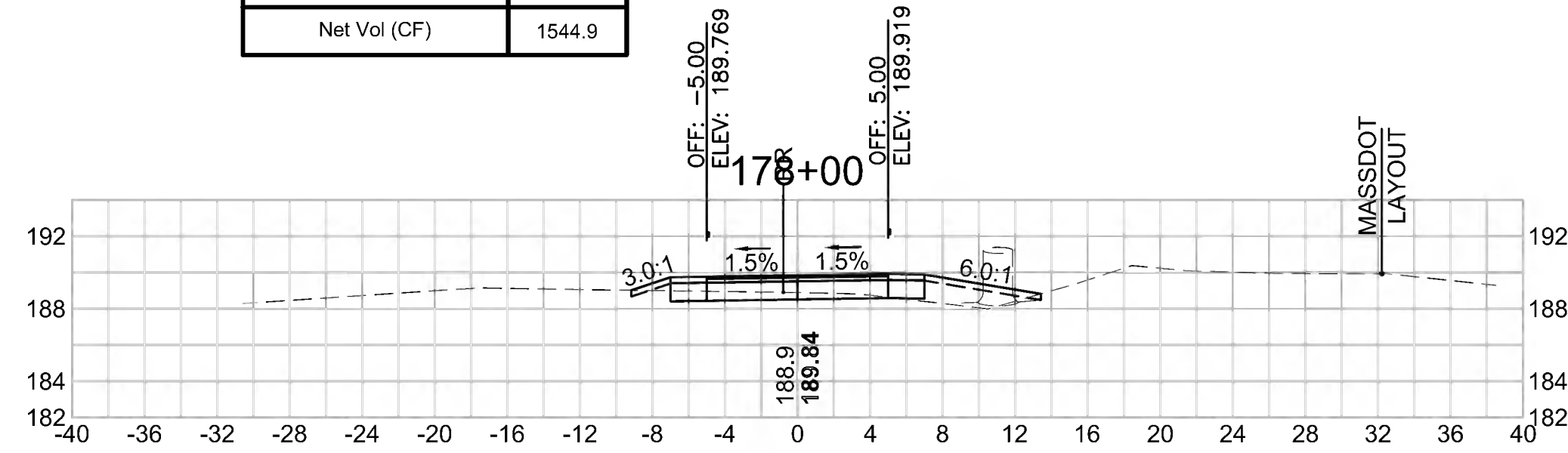

Total Volume at Station 179+50.00

Cut Area (SF)	1.604
Fill Area (SF)	6.535
Cut Vol (CF)	4.0
Fill Vol (CF)	14.3
Cum Cut Vol (CF)	5144.2
Cum Fill Vol (CF)	3622.1
Net Vol (CF)	1522.1

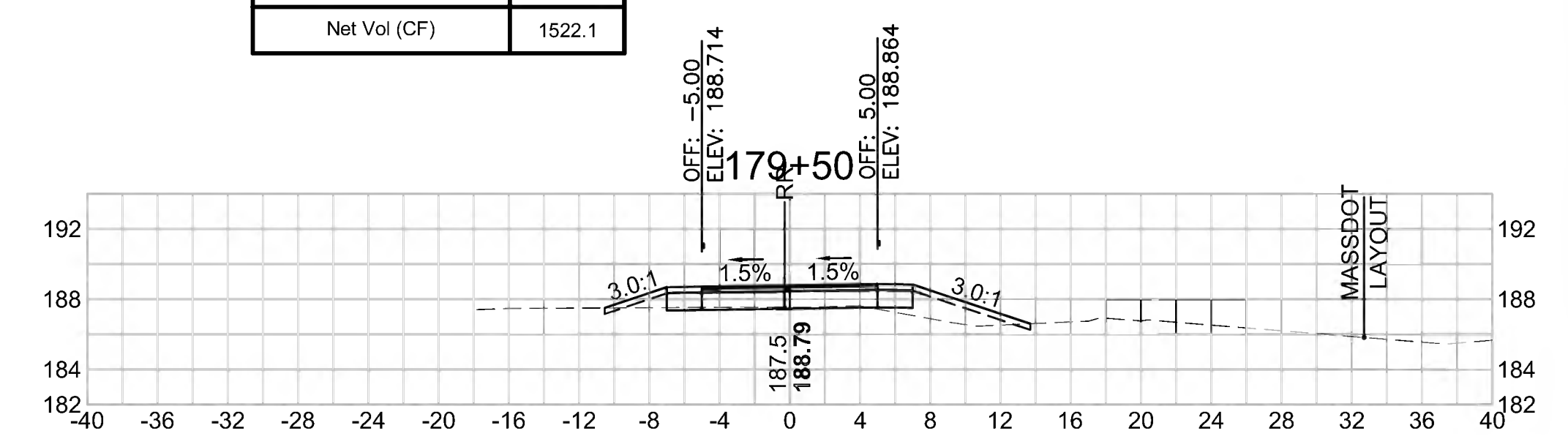

Total Volume at Station 176+00.00

Cut Area (SF)	41.902
Fill Area (SF)	0.153
Cut Vol (CF)	96.5
Fill Vol (CF)	0.1
Cum Cut Vol (CF)	4979.3
Cum Fill Vol (CF)	3556.5
Net Vol (CF)	1422.8

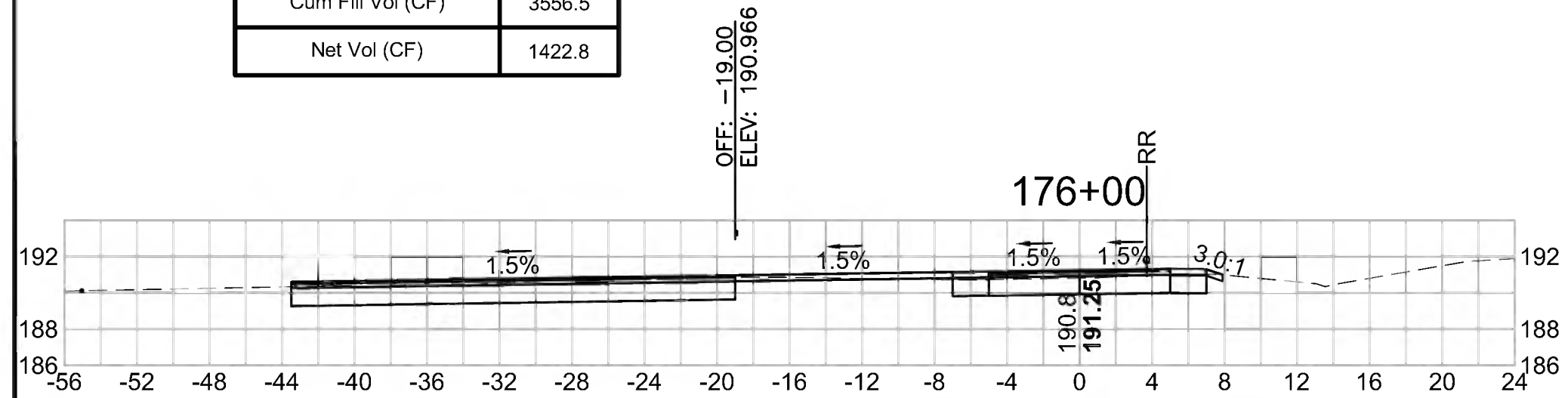

Total Volume at Station 177+50.00

Cut Area (SF)	5.150
Fill Area (SF)	4.434
Cut Vol (CF)	23.1
Fill Vol (CF)	9.5
Cum Cut Vol (CF)	5117.2
Cum Fill Vol (CF)	3572.9
Net Vol (CF)	1544.4

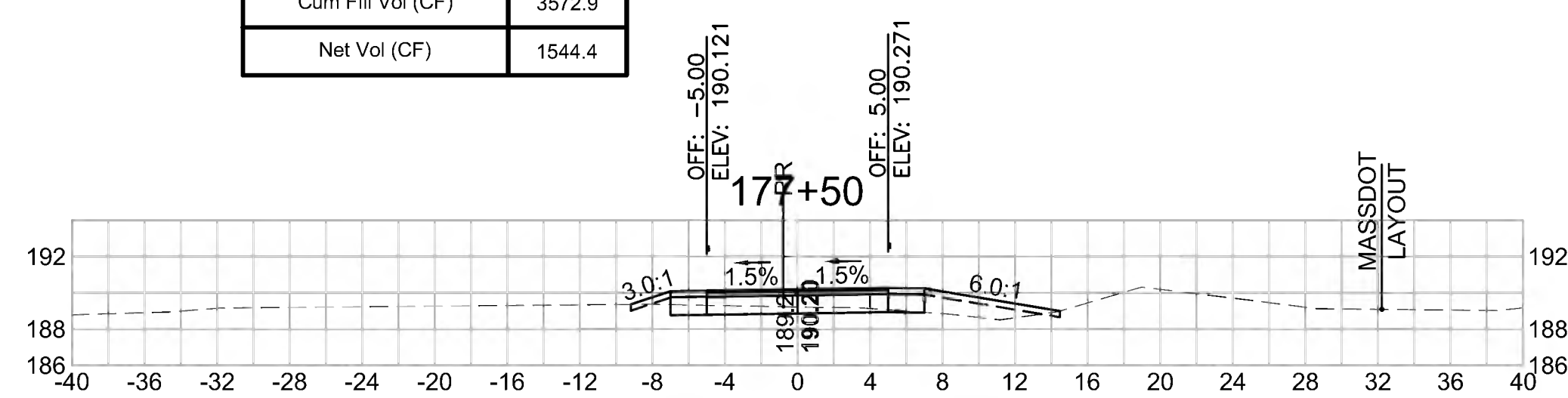

Total Volume at Station 179+00.00

Cut Area (SF)	2.731
Fill Area (SF)	8.930
Cut Vol (CF)	5.7
Fill Vol (CF)	14.8
Cum Cut Vol (CF)	5140.2
Cum Fill Vol (CF)	3607.8
Net Vol (CF)	1532.4

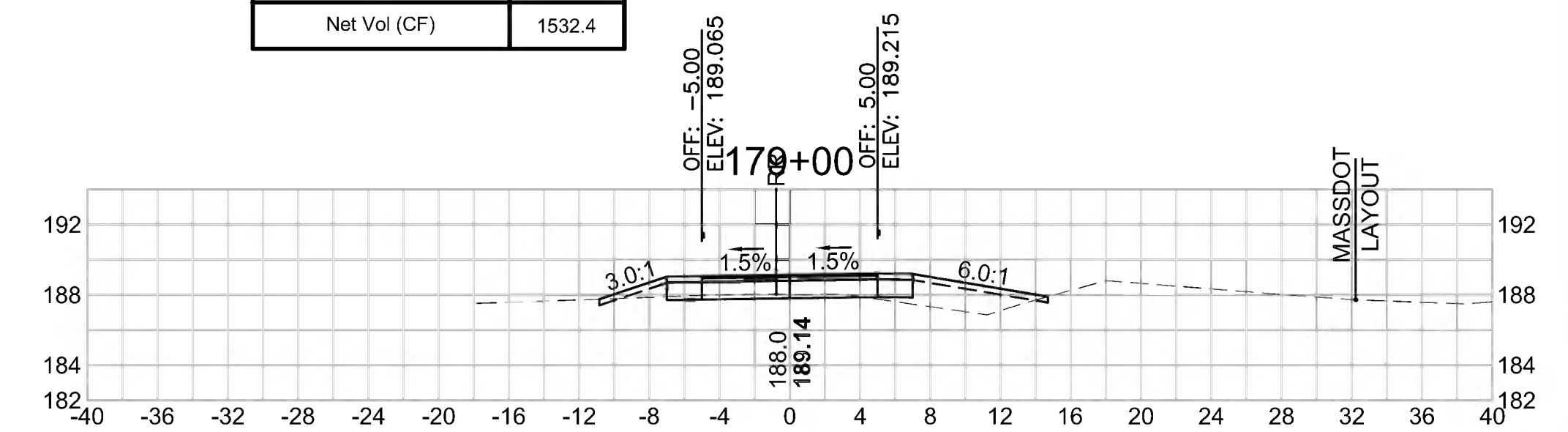

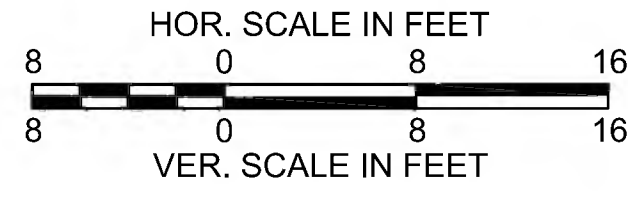

**SUDBURY
BRUCE FREEMAN RAIL TRAIL**

STATE	FED. AID PROJ. NO.	SHEET NO.	TOTAL SHEETS
MA	XXX-XXXX(XXX)X	264	319

PROJECT FILE NO. 608164

CROSS SECTIONS

Total Volume at Station 181+50.00

Cut Area (SF)	0.278
Fill Area (SF)	6.999
Cut Vol (CF)	0.6
Fill Vol (CF)	16.1
Cum Cut Vol (CF)	5148.0
Cum Fill Vol (CF)	3698.8
Net Vol (CF)	1449.1

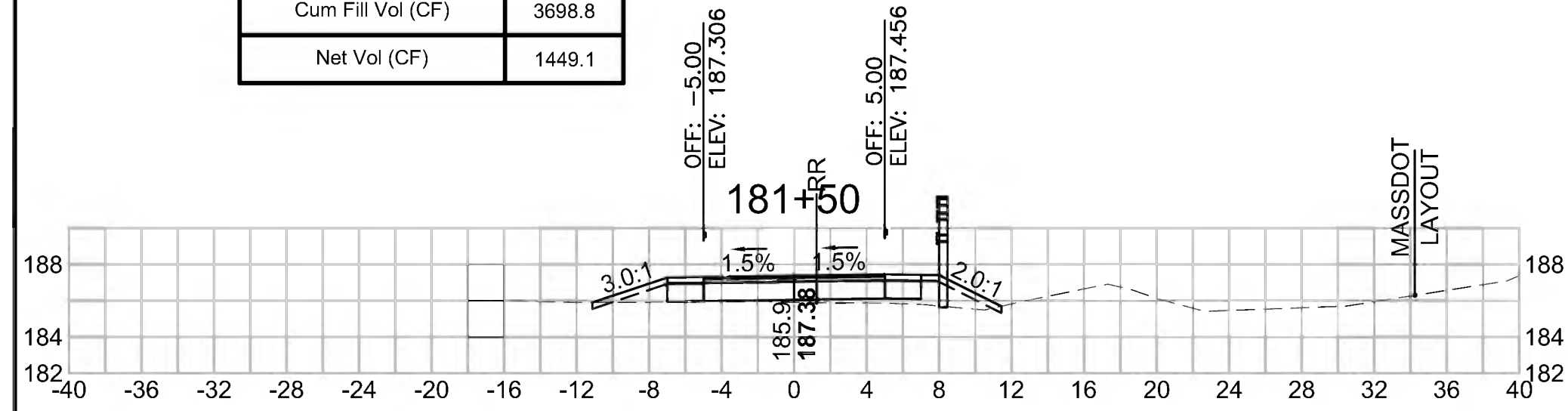

Total Volume at Station 183+00.00

Cut Area (SF)	0.791
Fill Area (SF)	5.820
Cut Vol (CF)	2.0
Fill Vol (CF)	10.3
Cum Cut Vol (CF)	5152.8
Cum Fill Vol (CF)	3732.4
Net Vol (CF)	1420.4

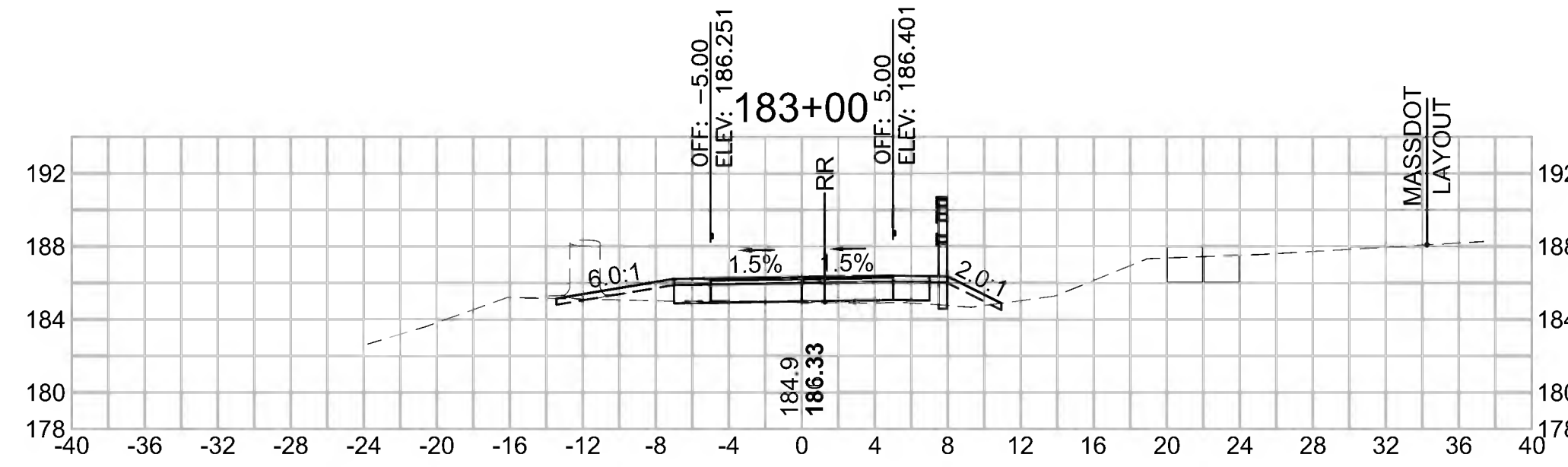

Total Volume at Station 184+50.00

Cut Area (SF)	1.145
Fill Area (SF)	3.314
Cut Vol (CF)	2.0
Fill Vol (CF)	8.8
Cum Cut Vol (CF)	5158.5
Cum Fill Vol (CF)	3763.1
Net Vol (CF)	1395.4

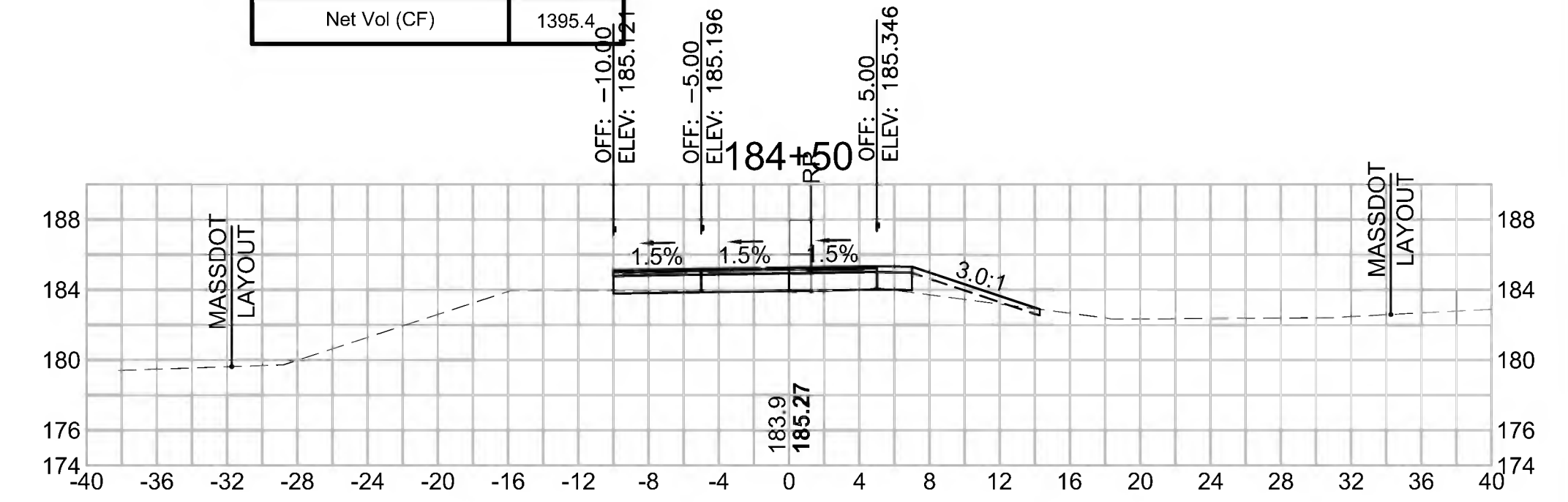

Total Volume at Station 181+00.00

Cut Area (SF)	0.334
Fill Area (SF)	10.418
Cut Vol (CF)	0.6
Fill Vol (CF)	17.1
Cum Cut Vol (CF)	5147.4
Cum Fill Vol (CF)	3682.7
Net Vol (CF)	1464.7

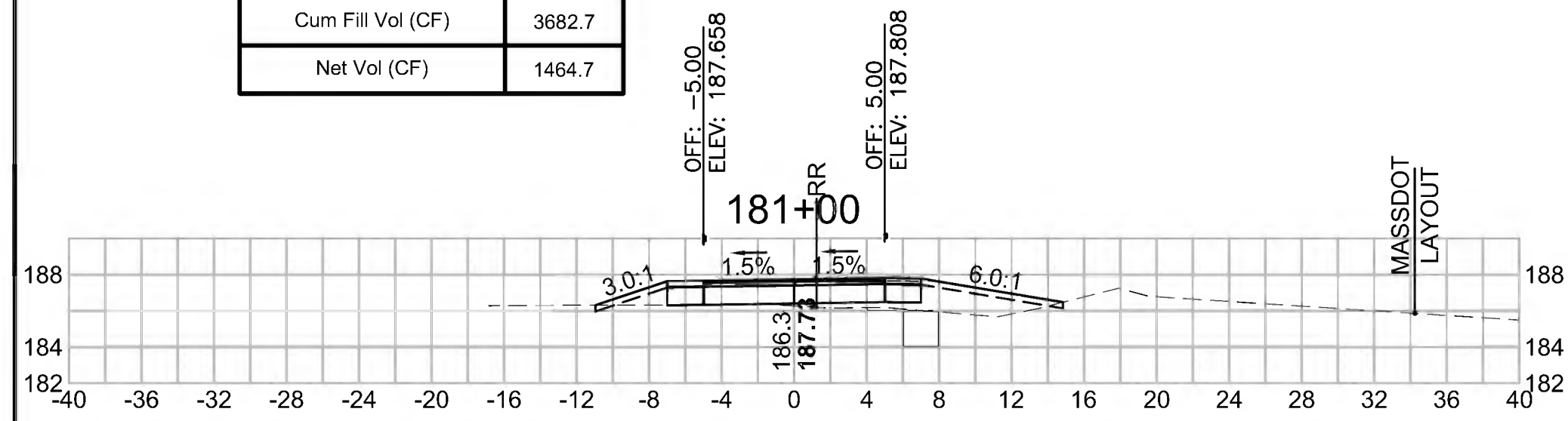

Total Volume at Station 182+50.00

Cut Area (SF)	1.337
Fill Area (SF)	5.296
Cut Vol (CF)	1.9
Fill Vol (CF)	10.9
Cum Cut Vol (CF)	5150.8
Cum Fill Vol (CF)	3722.2
Net Vol (CF)	1428.7

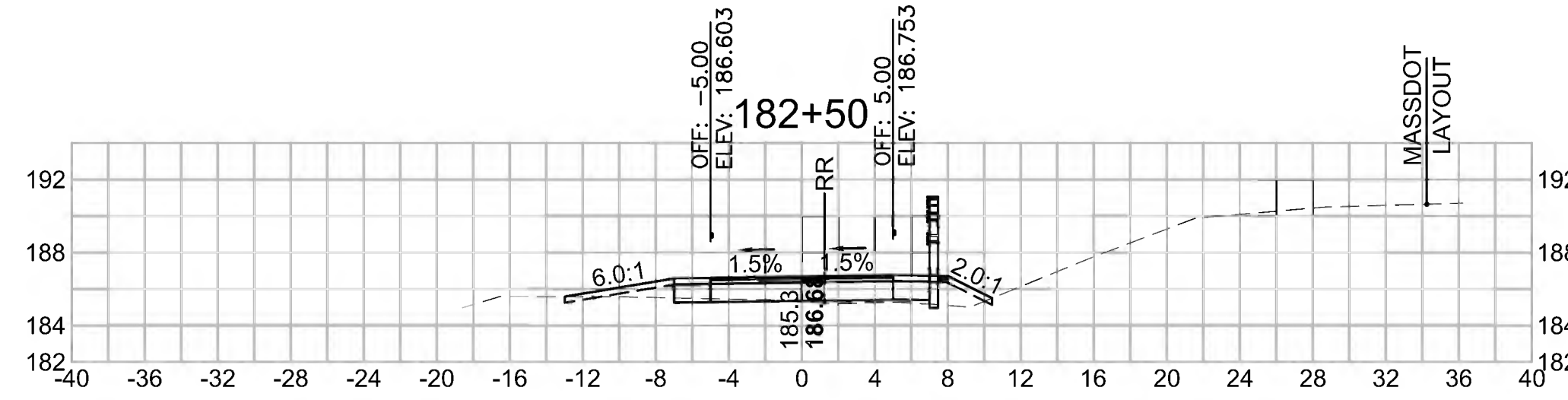

Total Volume at Station 184+00.00

Cut Area (SF)	1.053
Fill Area (SF)	6.216
Cut Vol (CF)	2.0
Fill Vol (CF)	11.1
Cum Cut Vol (CF)	5156.5
Cum Fill Vol (CF)	3754.3
Net Vol (CF)	1402.2

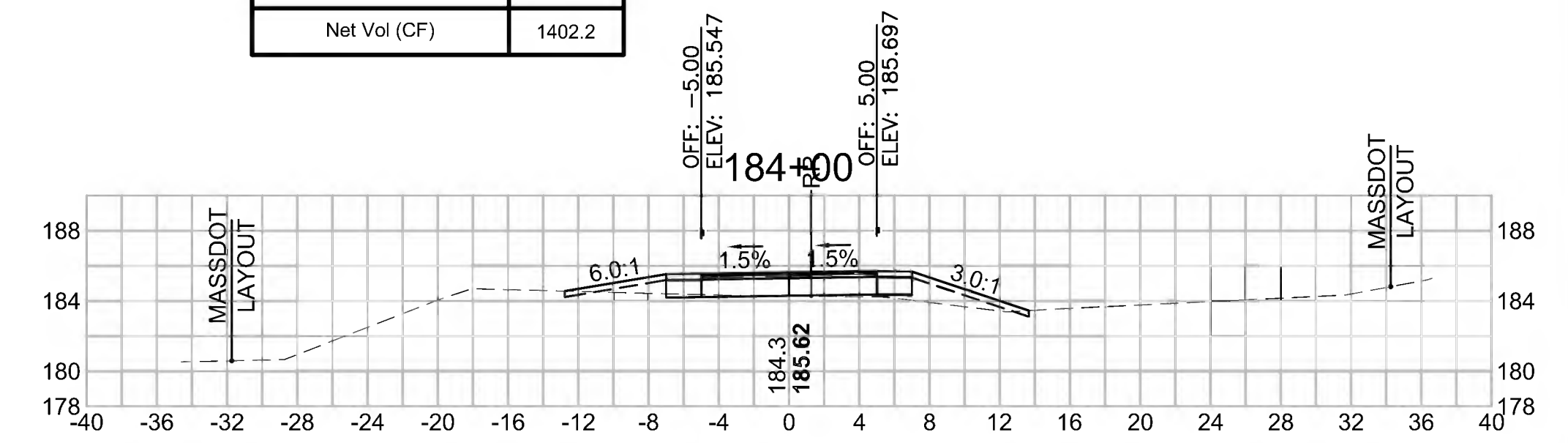

Total Volume at Station 180+50.00

Cut Area (SF)	0.335
Fill Area (SF)	8.098
Cut Vol (CF)	0.7
Fill Vol (CF)	22.4
Cum Cut Vol (CF)	5146.8
Cum Fill Vol (CF)	3665.6
Net Vol (CF)	1481.2

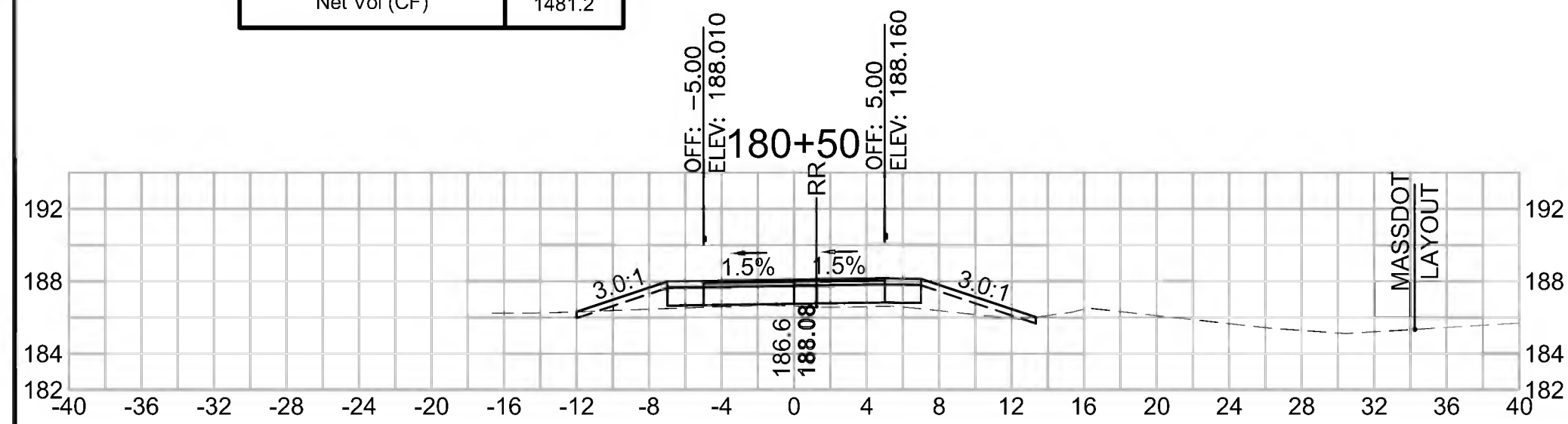

Total Volume at Station 182+00.00

Cut Area (SF)	0.744
Fill Area (SF)	6.447
Cut Vol (CF)	0.9
Fill Vol (CF)	12.4
Cum Cut Vol (CF)	5148.9
Cum Fill Vol (CF)	3711.3
Net Vol (CF)	1437.6

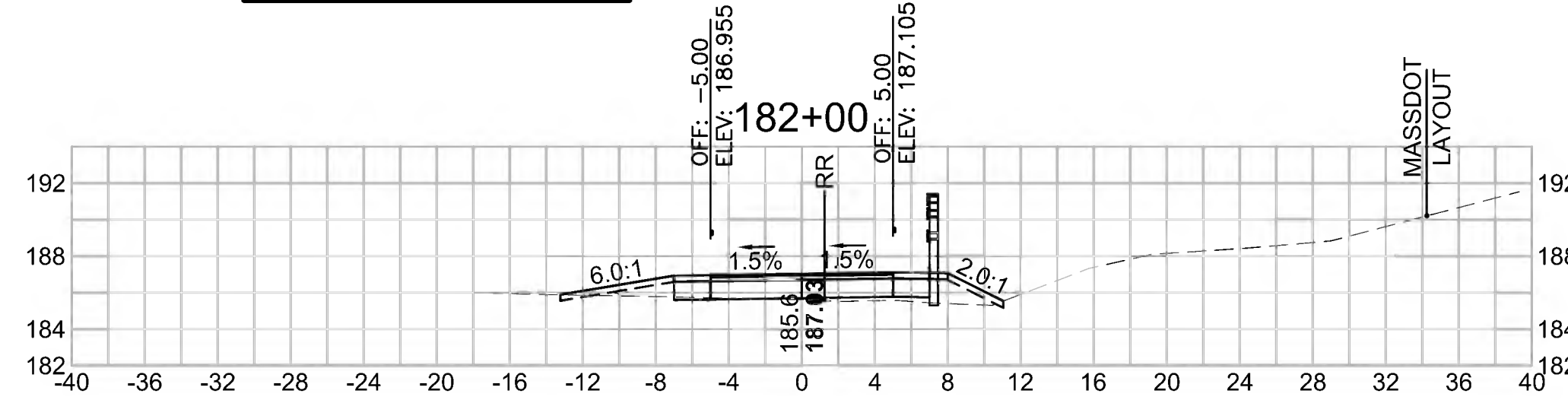

Total Volume at Station 183+50.00

Cut Area (SF)	1.072
Fill Area (SF)	5.768
Cut Vol (CF)	1.7
Fill Vol (CF)	10.7
Cum Cut Vol (CF)	5154.5
Cum Fill Vol (CF)	3743.2
Net Vol (CF)	1411.4

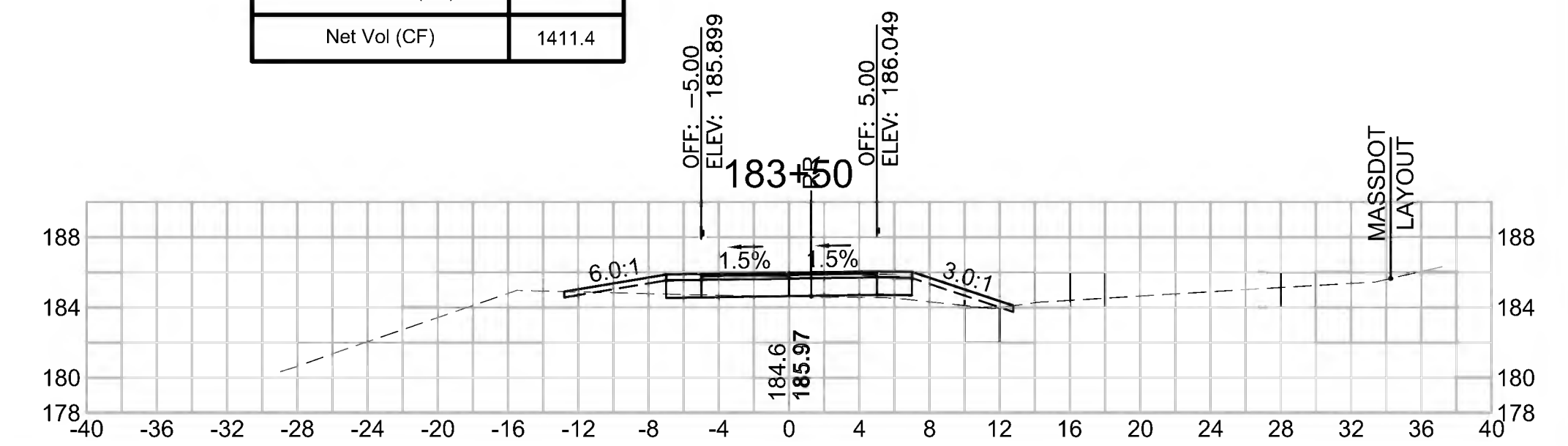

SUDBURY
BRUCE FREEMAN RAIL TRAIL

STATE	FED. AID PROJ. NO.	SHEET NO.	TOTAL SHEETS
MA	XXX-XXXX(XXX)X	265	319
PROJECT FILE NO. 608164			

CROSS SECTIONS

Total Volume at Station 186+00.00

Cut Area (SF)	0.462
Fill Area (SF)	4.352
Cut Vol (CF)	1.6
Fill Vol (CF)	10.0
Cum Cut Vol (CF)	5166.0
Cum Fill Vol (CF)	3801.8
Net Vol (CF)	1364.2

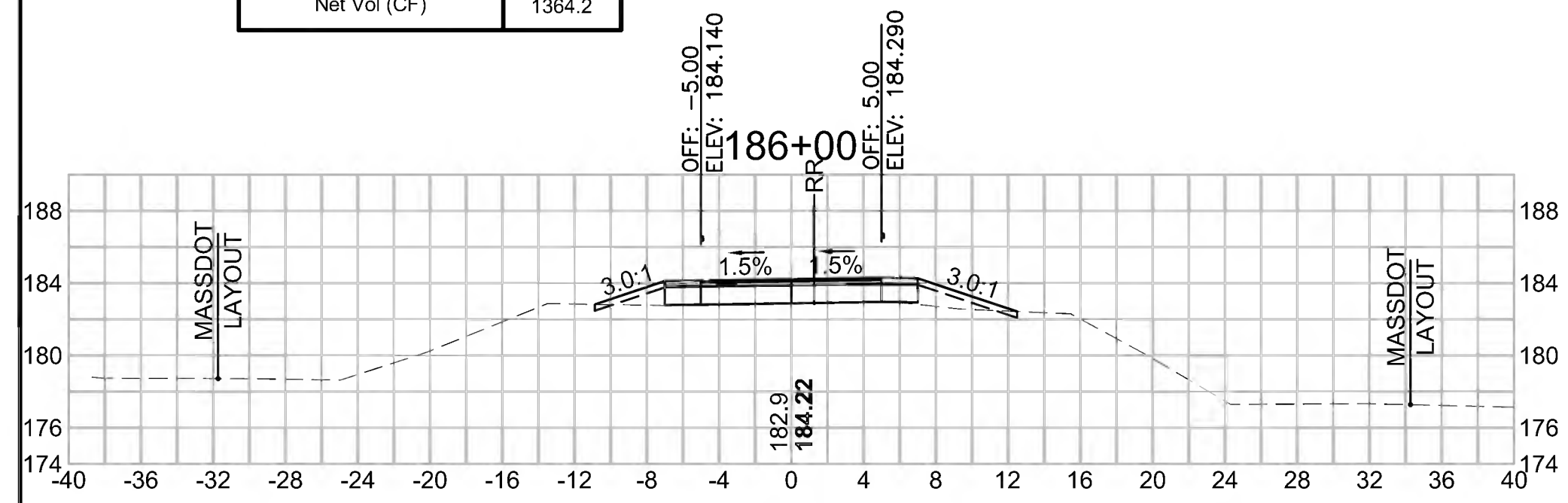

Total Volume at Station 187+50.00

Cut Area (SF)	3.419
Fill Area (SF)	7.150
Cut Vol (CF)	4.6
Fill Vol (CF)	16.3
Cum Cut Vol (CF)	5173.3
Cum Fill Vol (CF)	3861.1
Net Vol (CF)	1312.2

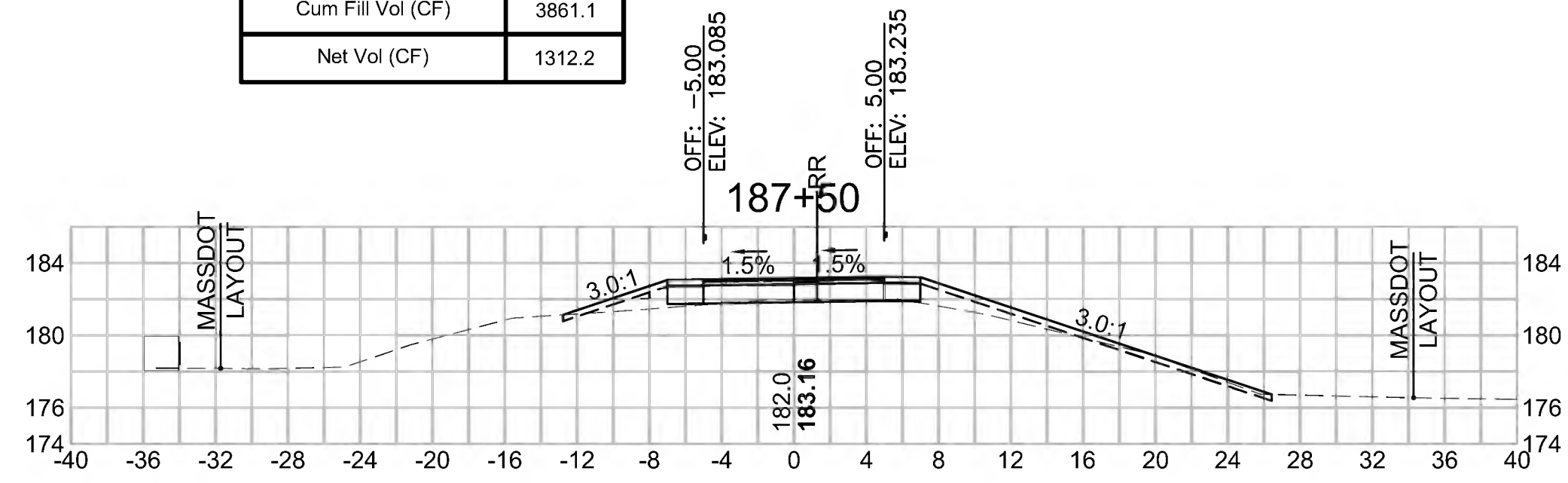

Total Volume at Station 189+00.00

Cut Area (SF)	1.251
Fill Area (SF)	13.957
Cut Vol (CF)	2.2
Fill Vol (CF)	19.4
Cum Cut Vol (CF)	5182.5
Cum Fill Vol (CF)	3904.9
Net Vol (CF)	1277.6

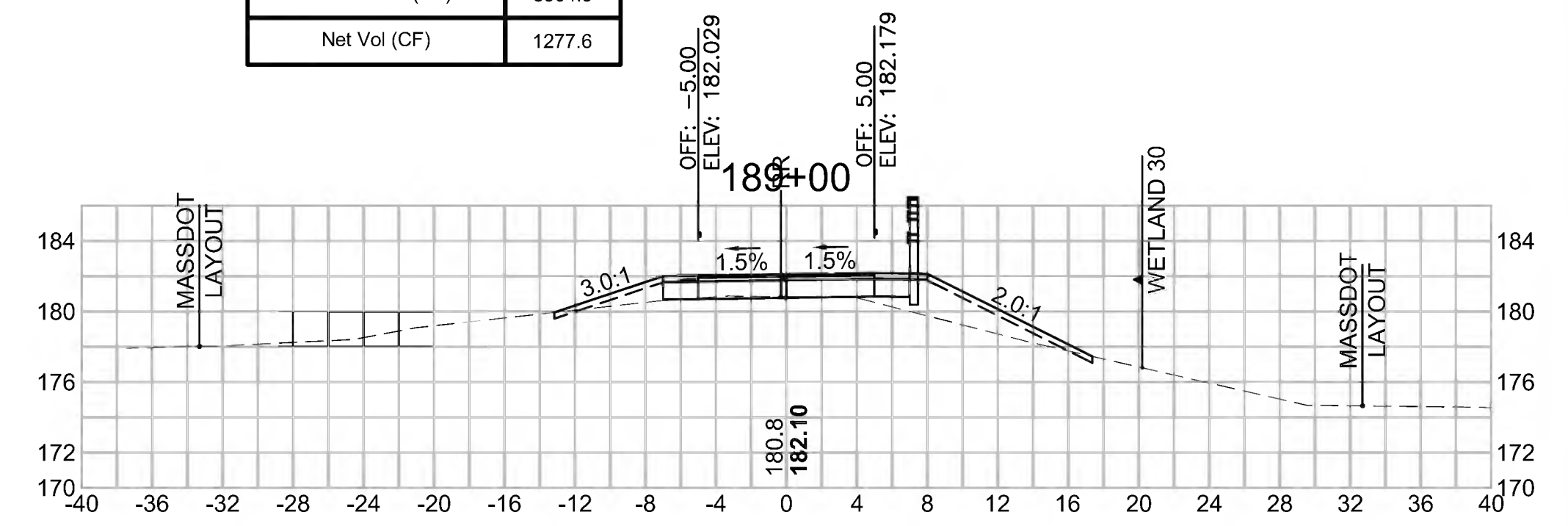

Total Volume at Station 185+50.00

Cut Area (SF)	1.227
Fill Area (SF)	6.499
Cut Vol (CF)	3.0
Fill Vol (CF)	15.8
Cum Cut Vol (CF)	5164.4
Cum Fill Vol (CF)	3791.7
Net Vol (CF)	1372.7

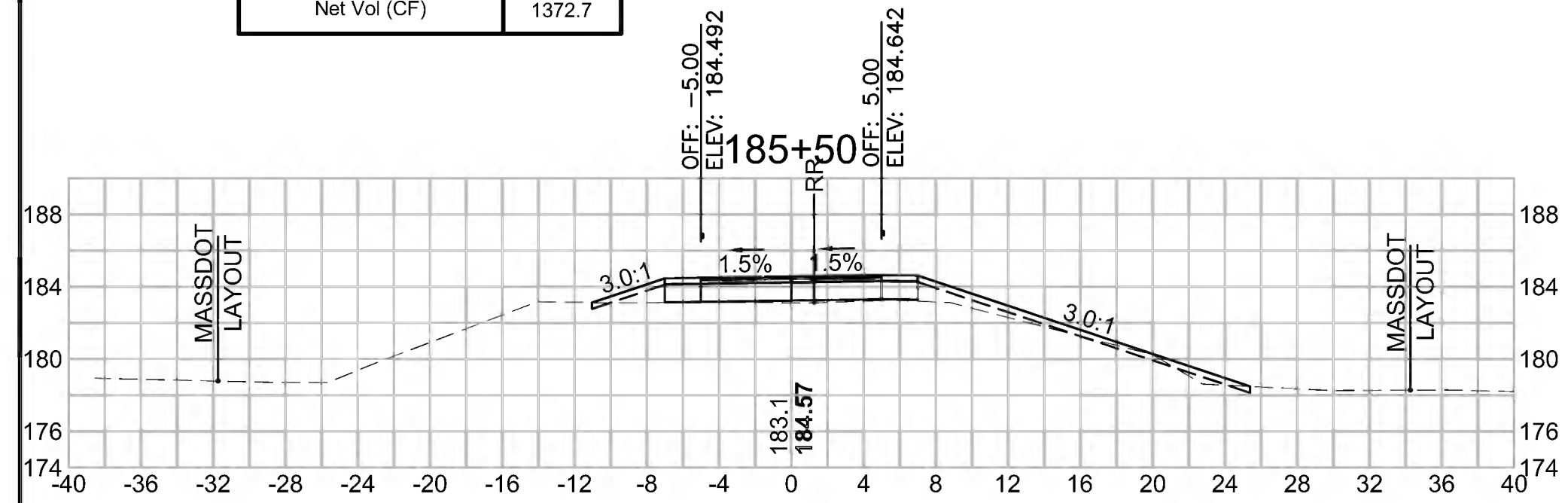

Total Volume at Station 187+00.00

Cut Area (SF)	1.507
Fill Area (SF)	10.401
Cut Vol (CF)	1.9
Fill Vol (CF)	24.3
Cum Cut Vol (CF)	5168.8
Cum Fill Vol (CF)	3844.9
Net Vol (CF)	1323.9

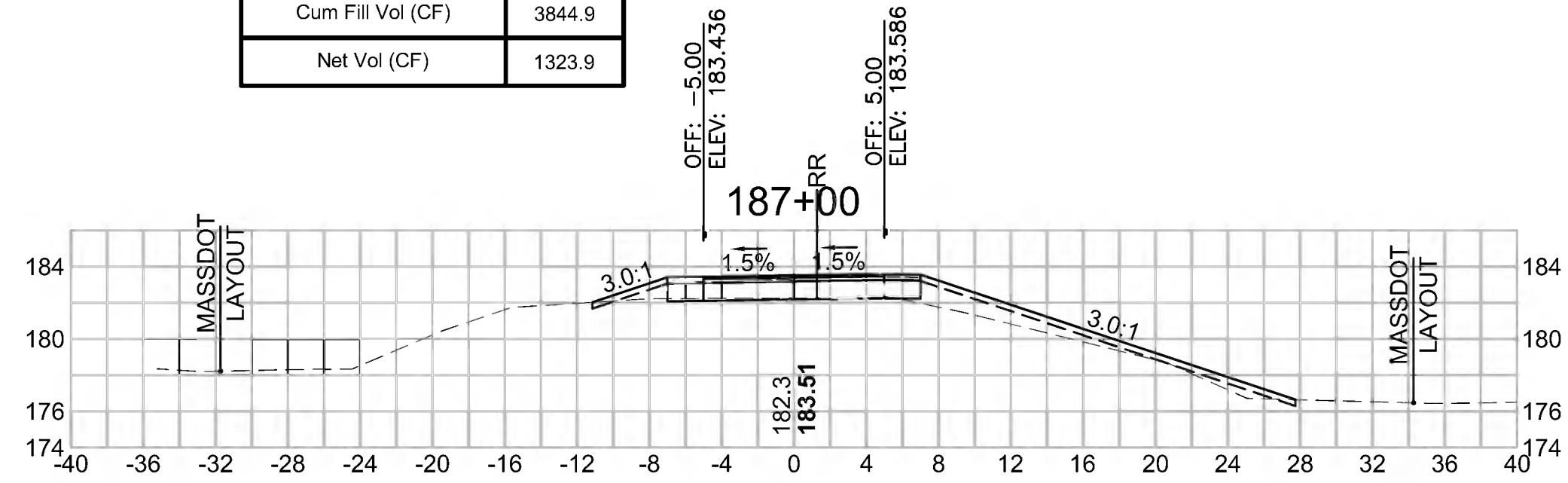

Total Volume at Station 188+50.00

Cut Area (SF)	1.109
Fill Area (SF)	6.981
Cut Vol (CF)	2.4
Fill Vol (CF)	12.1
Cum Cut Vol (CF)	5180.4
Cum Fill Vol (CF)	3885.5
Net Vol (CF)	1294.8

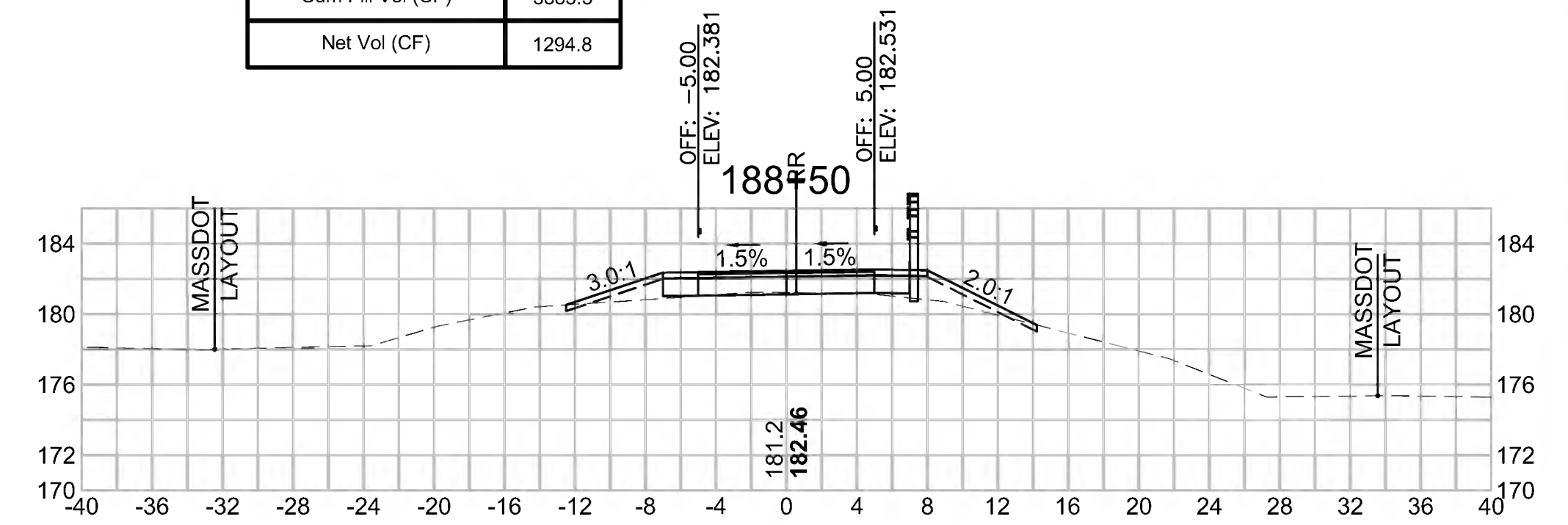

Total Volume at Station 185+00.00

Cut Area (SF)	1.999
Fill Area (SF)	10.564
Cut Vol (CF)	2.9
Fill Vol (CF)	12.9
Cum Cut Vol (CF)	5161.4
Cum Fill Vol (CF)	3775.9
Net Vol (CF)	1385.5

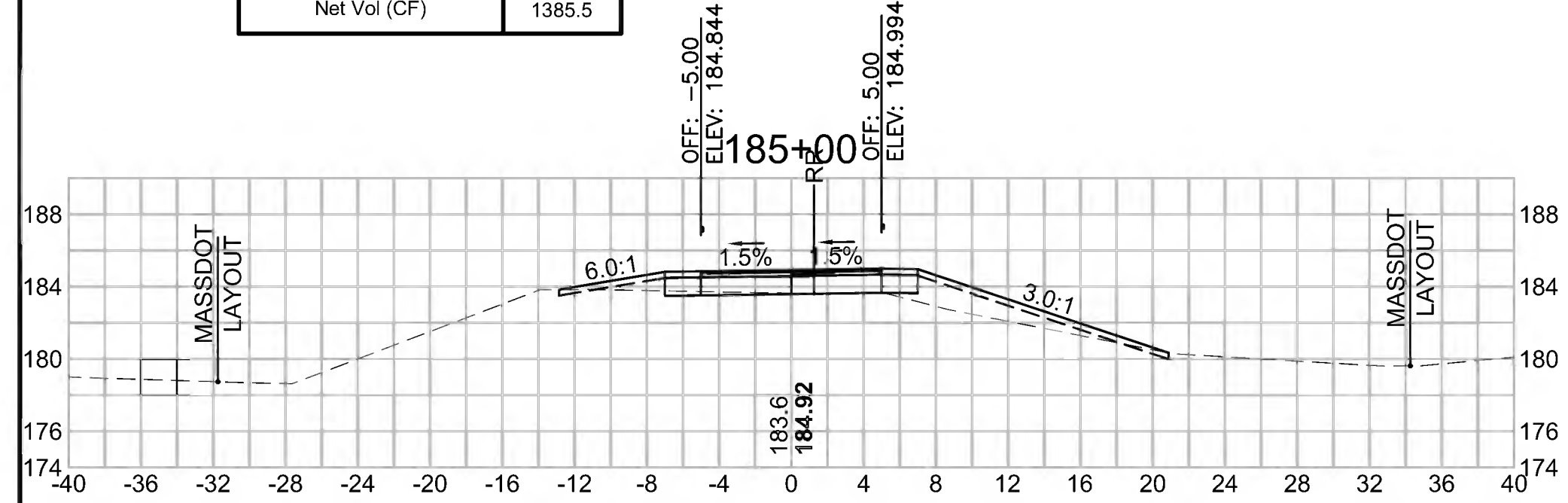

Total Volume at Station 186+50.00

Cut Area (SF)	0.508
Fill Area (SF)	15.875
Cut Vol (CF)	0.9
Fill Vol (CF)	18.7
Cum Cut Vol (CF)	5166.9
Cum Fill Vol (CF)	3820.5
Net Vol (CF)	1346.4

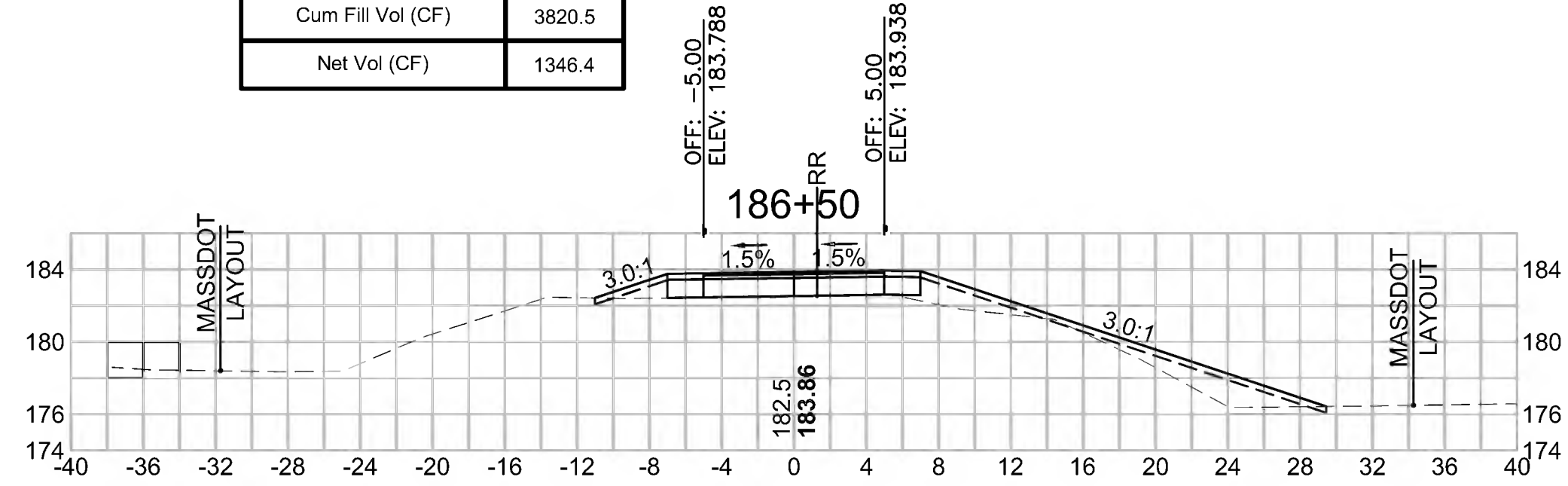

Total Volume at Station 188+00.00

Cut Area (SF)	1.534
Fill Area (SF)	6.123
Cut Vol (CF)	4.6
Fill Vol (CF)	12.3
Cum Cut Vol (CF)	5177.9
Cum Fill Vol (CF)	3873.4
Net Vol (CF)	1304.5

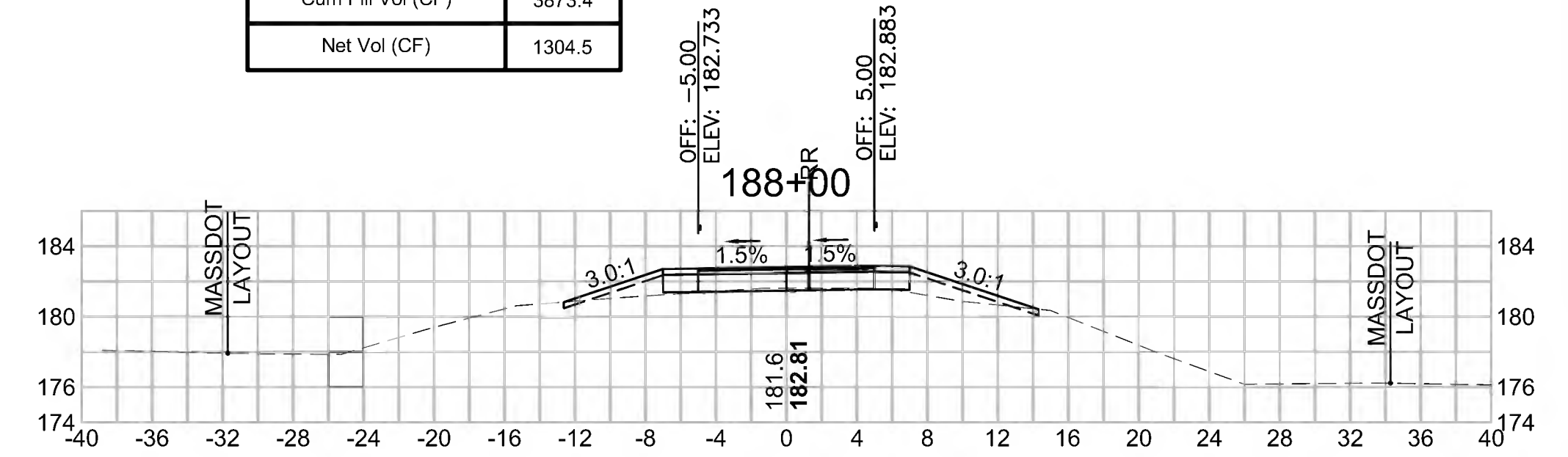

SUDBURY
BRUCE FREEMAN RAIL TRAIL

STATE	FED. AID PROJ. NO.	SHEET NO.	TOTAL SHEETS
MA	XXX-XXXX(XXX)X	266	319
PROJECT FILE NO. 608164			

CROSS SECTIONS

Total Volume at Station 190+50.00	
Cut Area (SF)	1.044
Fill Area (SF)	21.744
Cut Vol (CF)	1.9
Fill Vol (CF)	36.0
Cum Cut Vol (CF)	5188.8
Cum Fill Vol (CF)	4000.5
Net Vol (CF)	1188.4

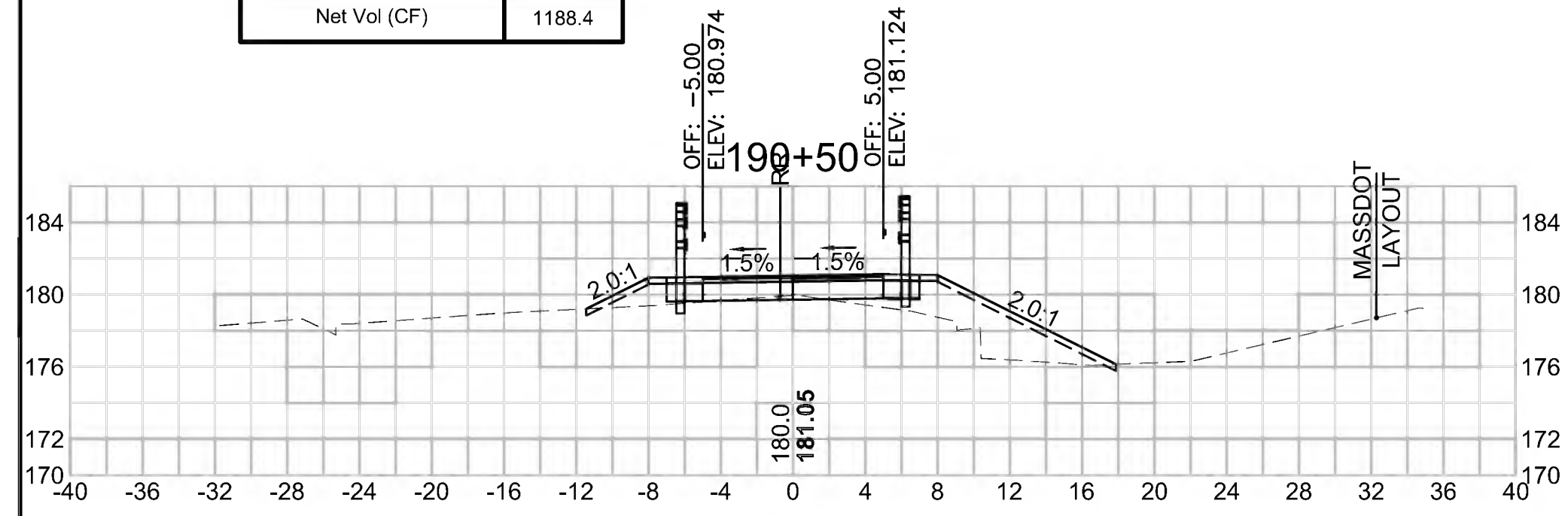

Total Volume at Station 192+00.00	
Cut Area (SF)	2.351
Fill Area (SF)	8.757
Cut Vol (CF)	4.1
Fill Vol (CF)	20.9
Cum Cut Vol (CF)	5199.7
Cum Fill Vol (CF)	4085.8
Net Vol (CF)	1113.8

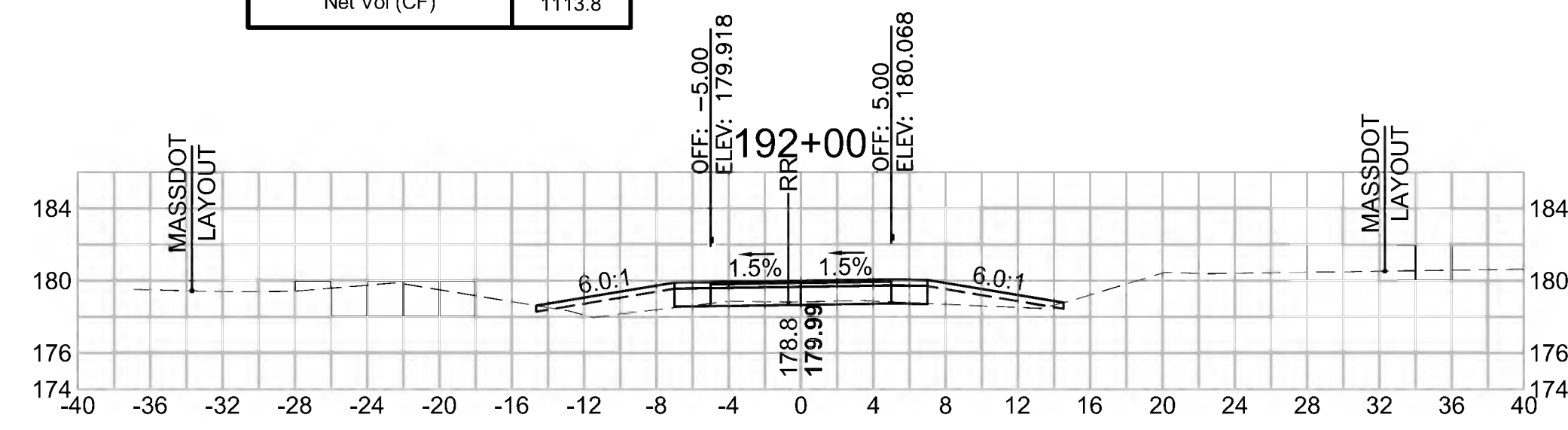

Total Volume at Station 193+50.00	
Cut Area (SF)	5.195
Fill Area (SF)	9.553
Cut Vol (CF)	8.1
Fill Vol (CF)	20.9
Cum Cut Vol (CF)	5220.0
Cum Fill Vol (CF)	4143.2
Net Vol (CF)	1076.8

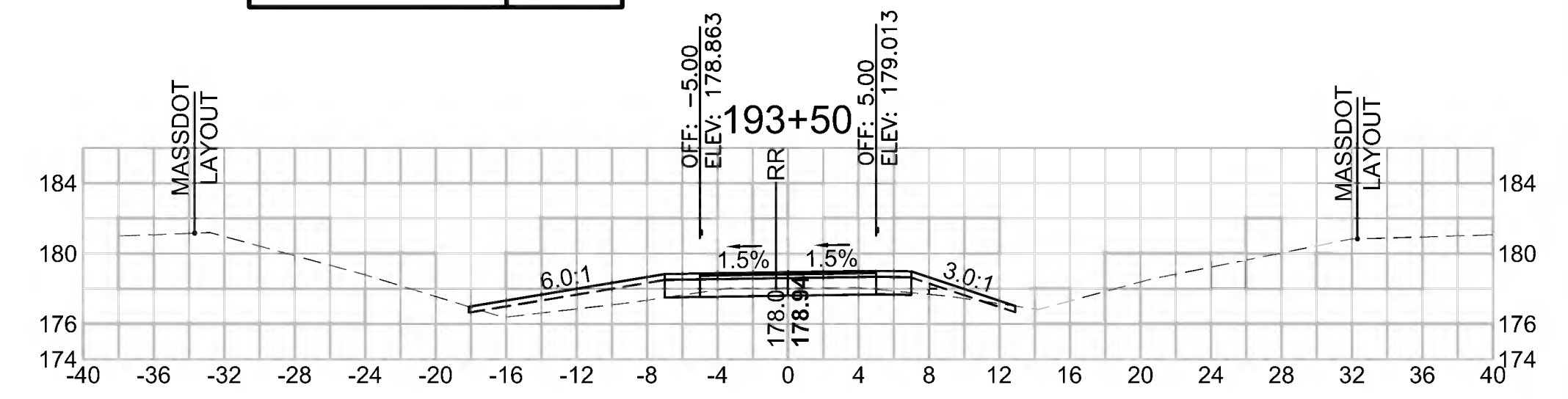

Total Volume at Station 190+00.00	
Cut Area (SF)	0.993
Fill Area (SF)	17.137
Cut Vol (CF)	2.1
Fill Vol (CF)	31.2
Cum Cut Vol (CF)	5186.9
Cum Fill Vol (CF)	3964.5
Net Vol (CF)	1222.5

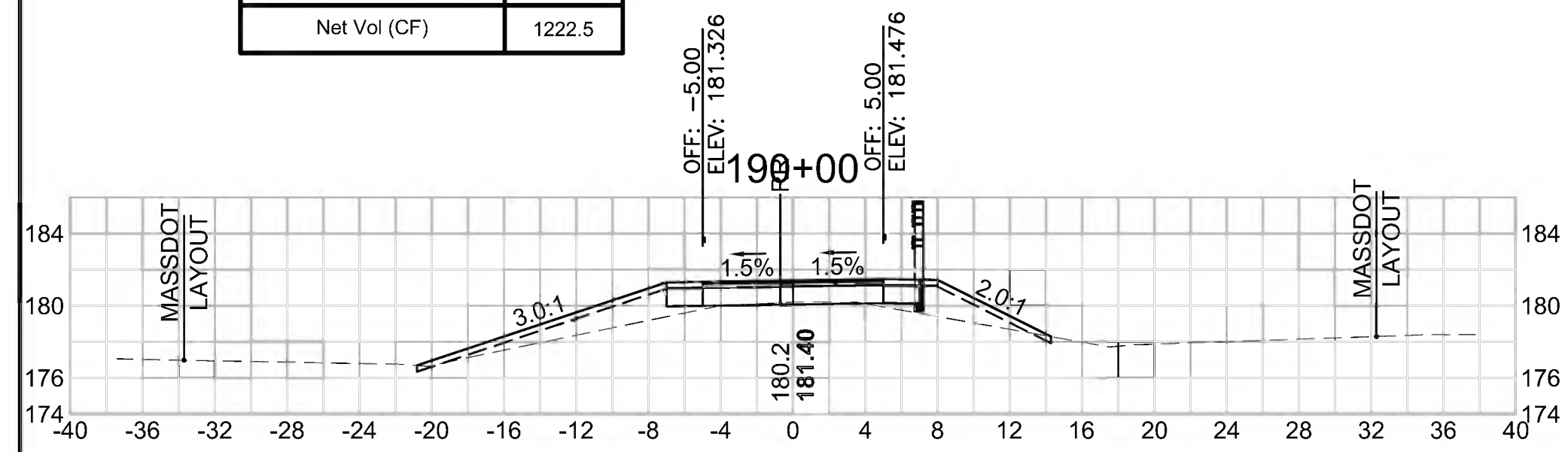

Total Volume at Station 191+50.00	
Cut Area (SF)	2.027
Fill Area (SF)	13.777
Cut Vol (CF)	3.9
Fill Vol (CF)	28.6
Cum Cut Vol (CF)	5195.6
Cum Fill Vol (CF)	4065.0
Net Vol (CF)	1130.7

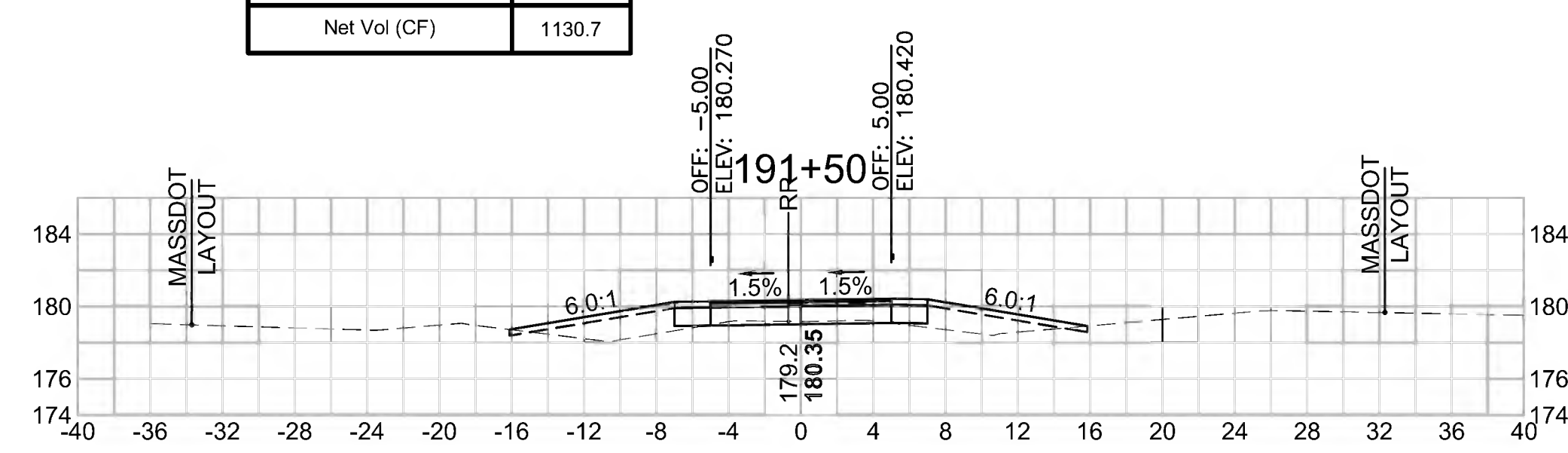

Total Volume at Station 193+00.00	
Cut Area (SF)	3.586
Fill Area (SF)	13.067
Cut Vol (CF)	6.7
Fill Vol (CF)	20.2
Cum Cut Vol (CF)	5211.9
Cum Fill Vol (CF)	4122.2
Net Vol (CF)	1089.7

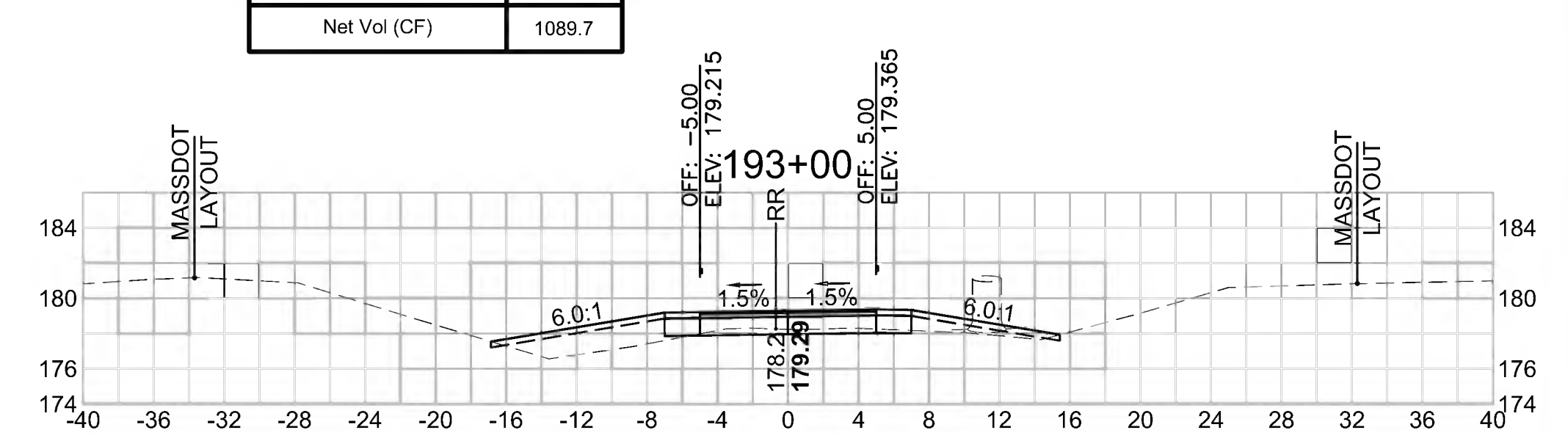

Total Volume at Station 189+50.00	
Cut Area (SF)	1.247
Fill Area (SF)	16.603
Cut Vol (CF)	2.3
Fill Vol (CF)	28.3
Cum Cut Vol (CF)	5184.9
Cum Fill Vol (CF)	3933.2
Net Vol (CF)	1251.6

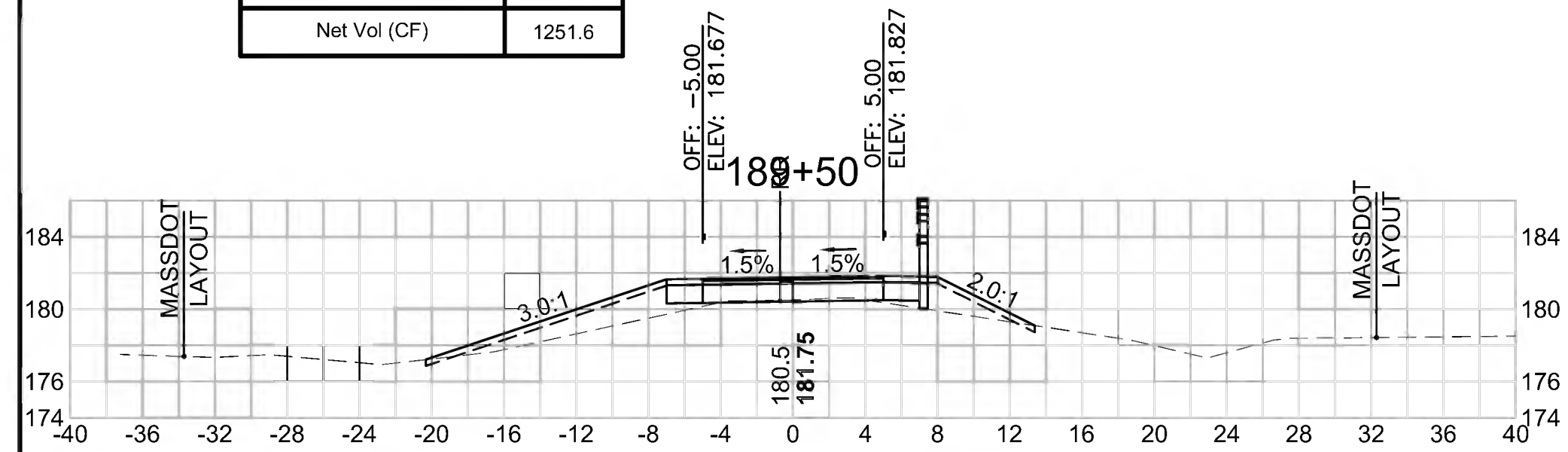

Total Volume at Station 191+00.00	
Cut Area (SF)	2.143
Fill Area (SF)	17.079
Cut Vol (CF)	3.0
Fill Vol (CF)	35.9
Cum Cut Vol (CF)	5191.8
Cum Fill Vol (CF)	4036.4
Net Vol (CF)	1155.4

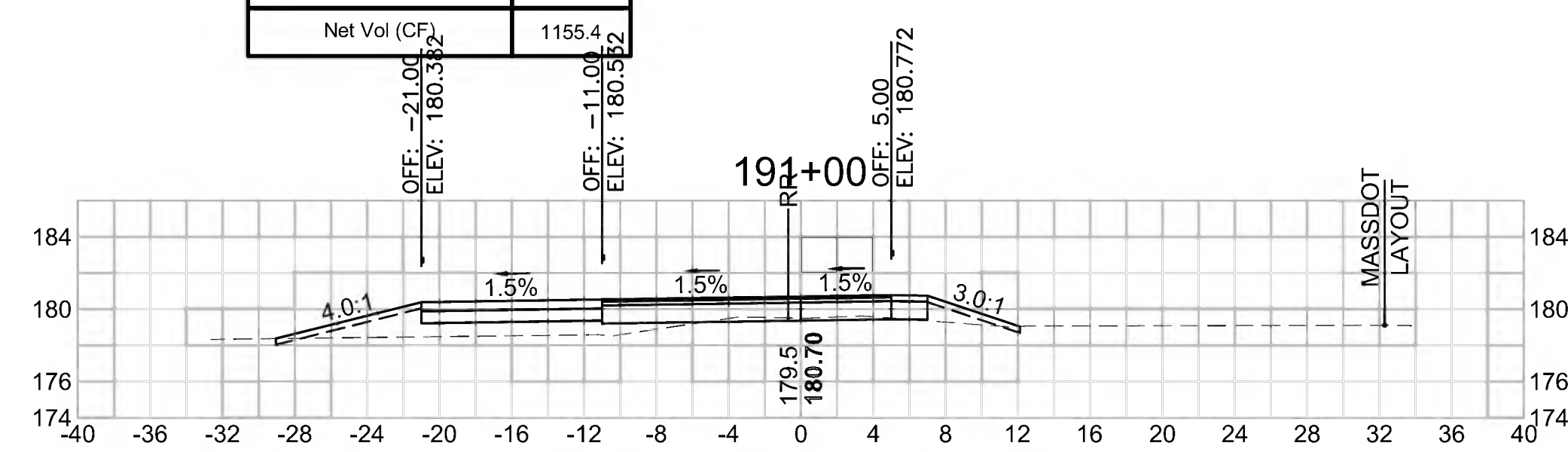

Total Volume at Station 192+50.00	
Cut Area (SF)	3.617
Fill Area (SF)	8.735
Cut Vol (CF)	5.5
Fill Vol (CF)	16.2
Cum Cut Vol (CF)	5205.2
Cum Fill Vol (CF)	4102.0
Net Vol (CF)	1103.2

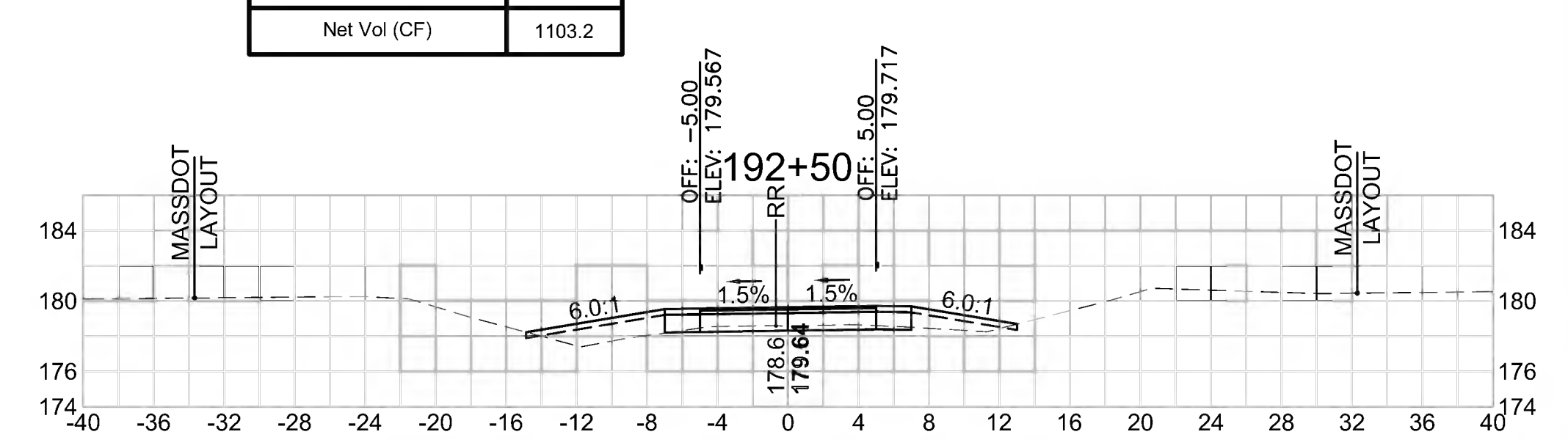

CROSS SECTIONS

Total Volume at Station 195+00.00

Cut Area (SF)	10.625
Fill Area (SF)	1.877
Cut Vol (CF)	15.3
Fill Vol (CF)	11.2
Cum Cut Vol (CF)	5257.8
Cum Fill Vol (CF)	4185.8
Net Vol (CF)	1072.0

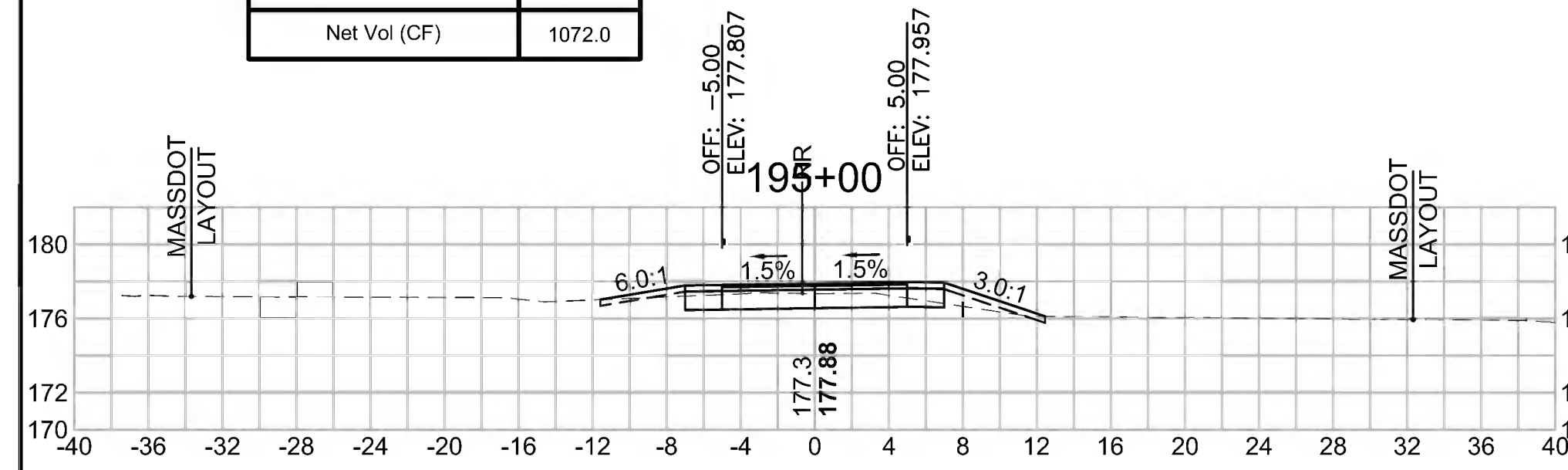

Total Volume at Station 196+50.00

Cut Area (SF)	31.301
Fill Area (SF)	0.000
Cut Vol (CF)	47.3
Fill Vol (CF)	0.0
Cum Cut Vol (CF)	5354.8
Cum Fill Vol (CF)	4191.7
Net Vol (CF)	1163.1

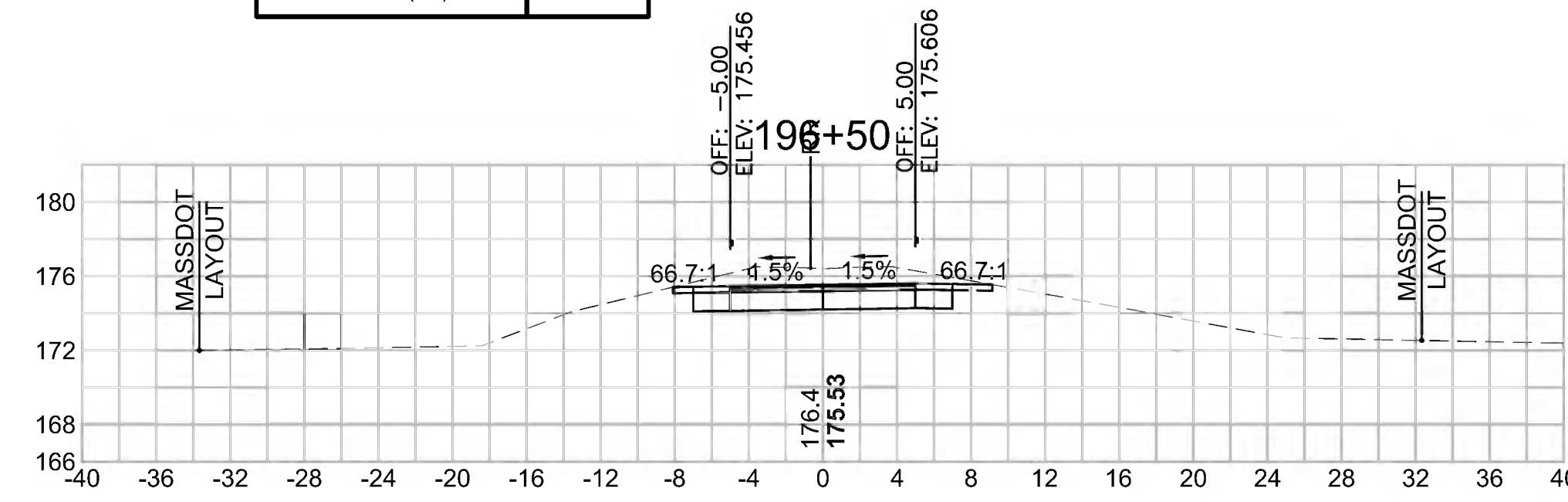

Total Volume at Station 198+00.00

Cut Area (SF)	32.247
Fill Area (SF)	0.000
Cut Vol (CF)	62.7
Fill Vol (CF)	0.0
Cum Cut Vol (CF)	5548.6
Cum Fill Vol (CF)	4191.7
Net Vol (CF)	1356.9

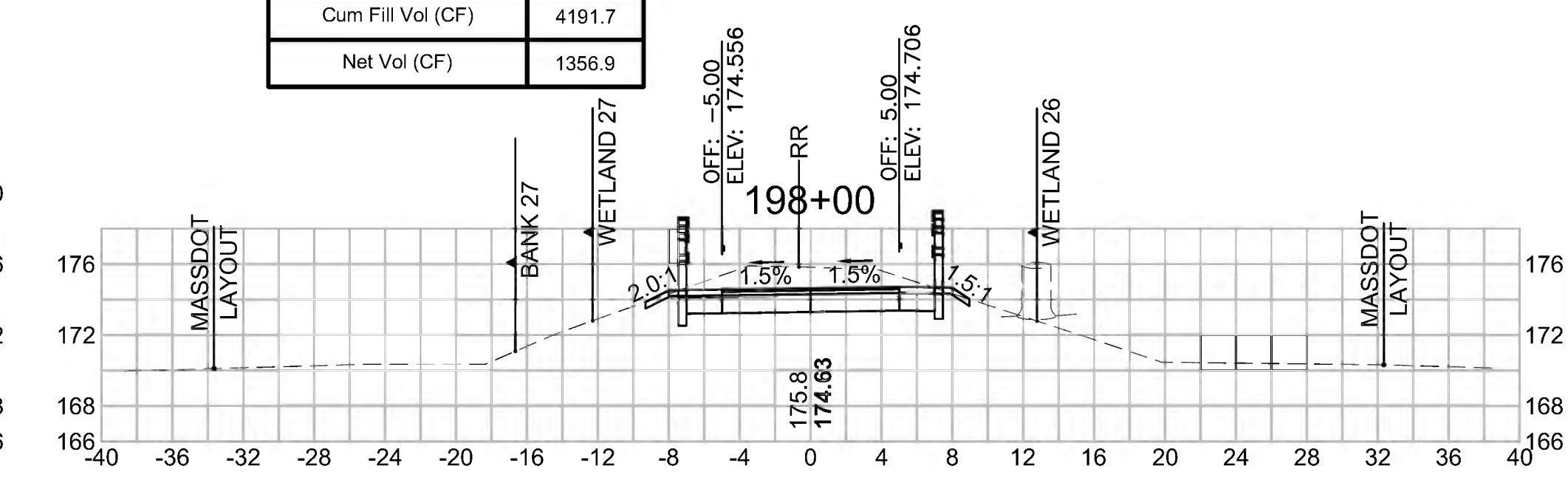

Total Volume at Station 194+50.00

Cut Area (SF)	5.936
Fill Area (SF)	10.223
Cut Vol (CF)	11.6
Fill Vol (CF)	16.0
Cum Cut Vol (CF)	5242.4
Cum Fill Vol (CF)	4174.6
Net Vol (CF)	1067.9

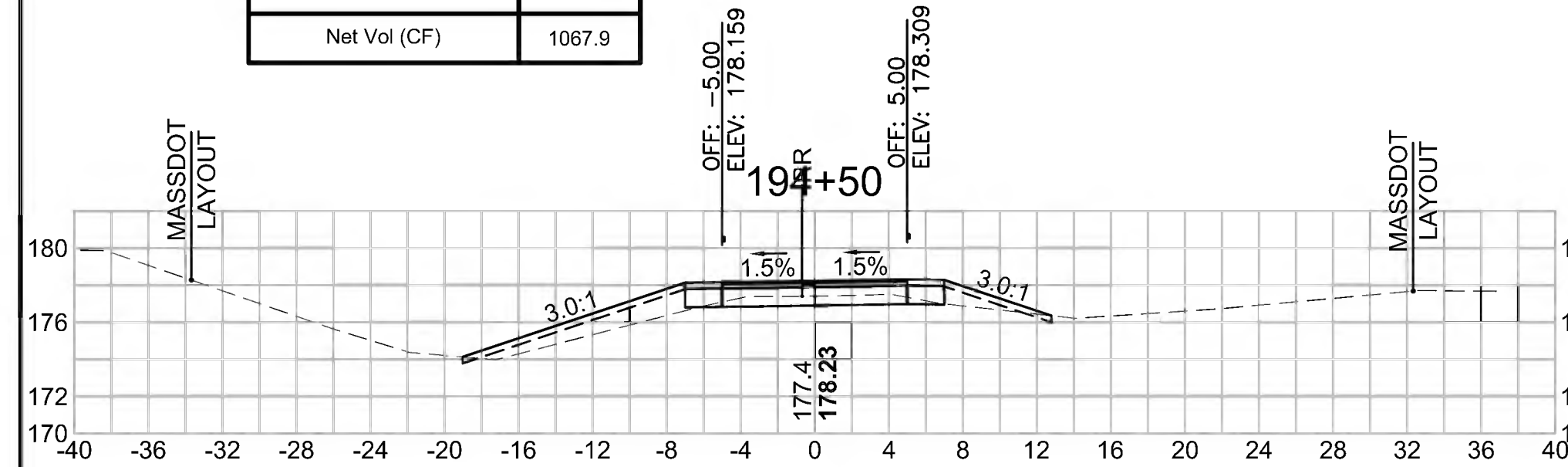

Total Volume at Station 196+00.00

Cut Area (SF)	19.737
Fill Area (SF)	0.012
Cut Vol (CF)	29.1
Fill Vol (CF)	2.1
Cum Cut Vol (CF)	5307.5
Cum Fill Vol (CF)	4191.7
Net Vol (CF)	1115.8

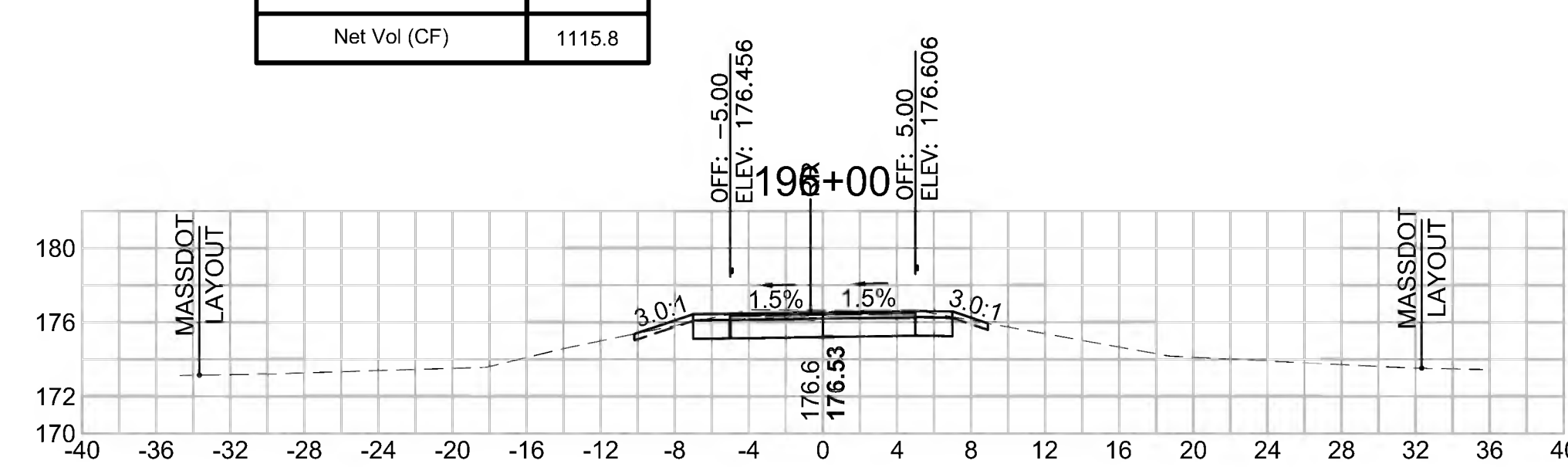

Total Volume at Station 197+50.00

Cut Area (SF)	35.520
Fill Area (SF)	0.012
Cut Vol (CF)	67.5
Fill Vol (CF)	0.0
Cum Cut Vol (CF)	5485.9
Cum Fill Vol (CF)	4191.7
Net Vol (CF)	1294.2

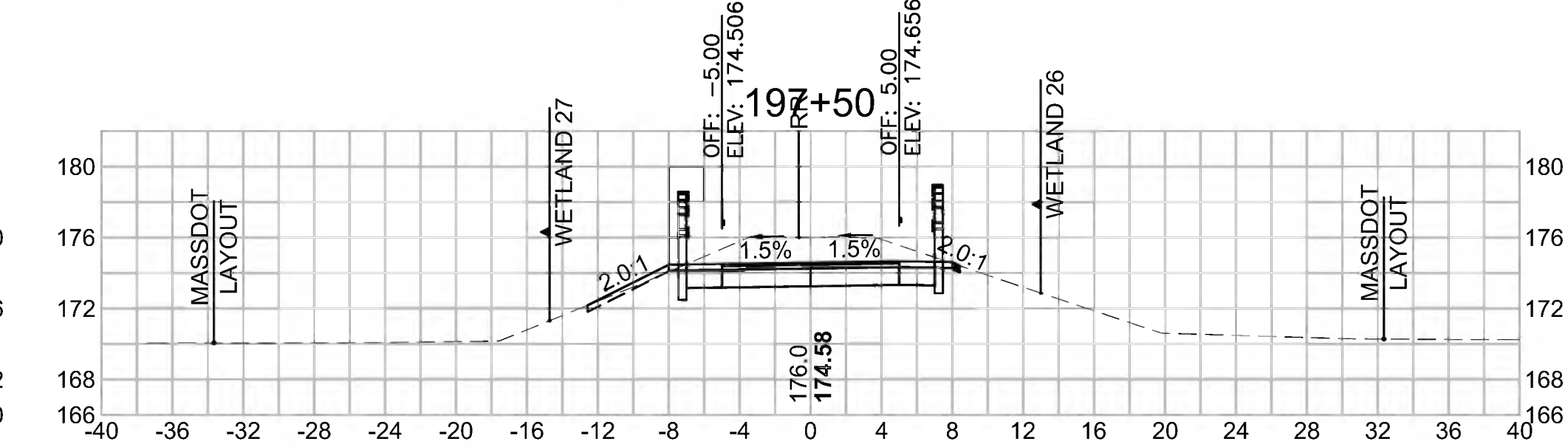

Total Volume at Station 194+00.00

Cut Area (SF)	6.552
Fill Area (SF)	7.062
Cut Vol (CF)	10.9
Fill Vol (CF)	15.4
Cum Cut Vol (CF)	5230.9
Cum Fill Vol (CF)	4158.5
Net Vol (CF)	1072.3

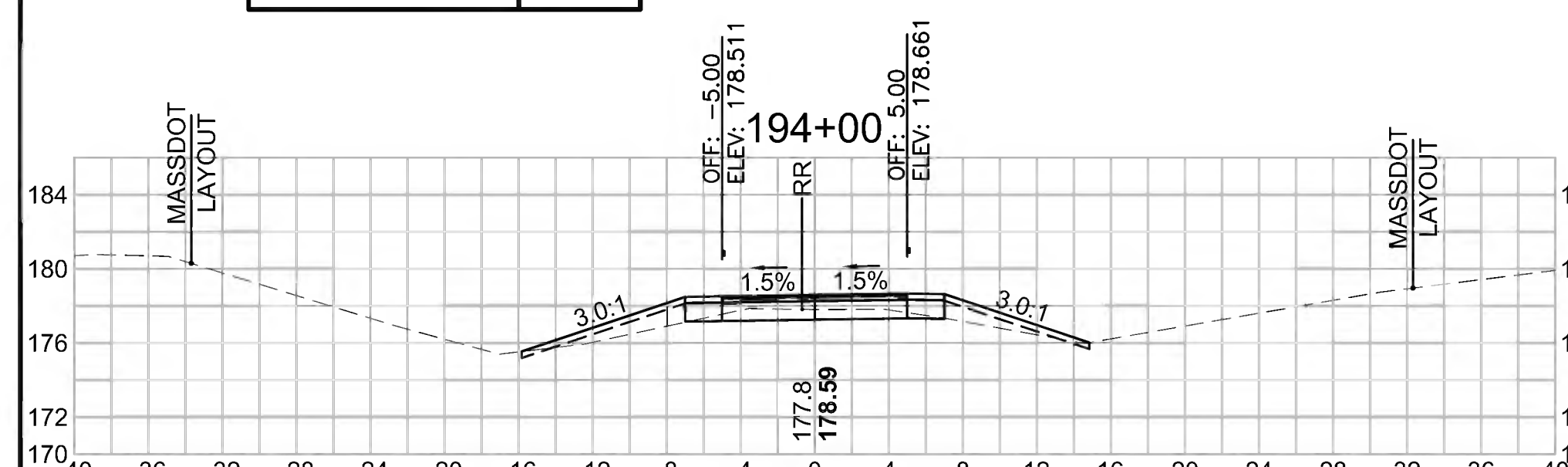

Total Volume at Station 195+50.00

Cut Area (SF)	11.672
Fill Area (SF)	2.250
Cut Vol (CF)	20.6
Fill Vol (CF)	3.8
Cum Cut Vol (CF)	5278.4
Cum Fill Vol (CF)	4189.6
Net Vol (CF)	1088.9

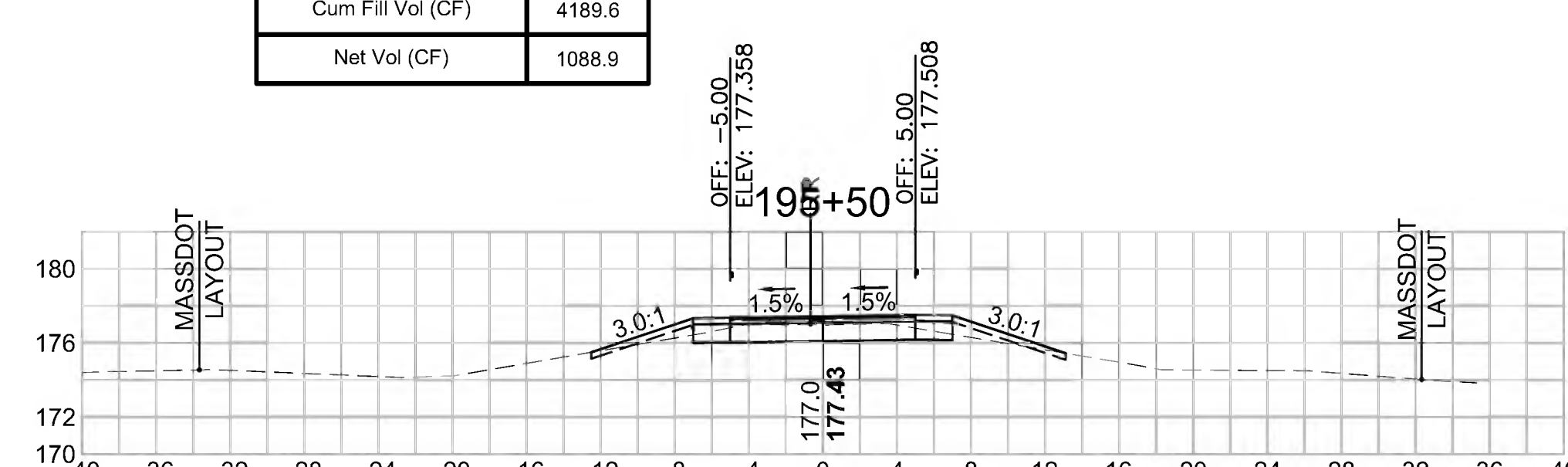

Total Volume at Station 197+00.00

Cut Area (SF)	37.377
Fill Area (SF)	0.000
Cut Vol (CF)	63.6
Fill Vol (CF)	0.0
Cum Cut Vol (CF)	5418.4
Cum Fill Vol (CF)	4191.7
Net Vol (CF)	1226.7

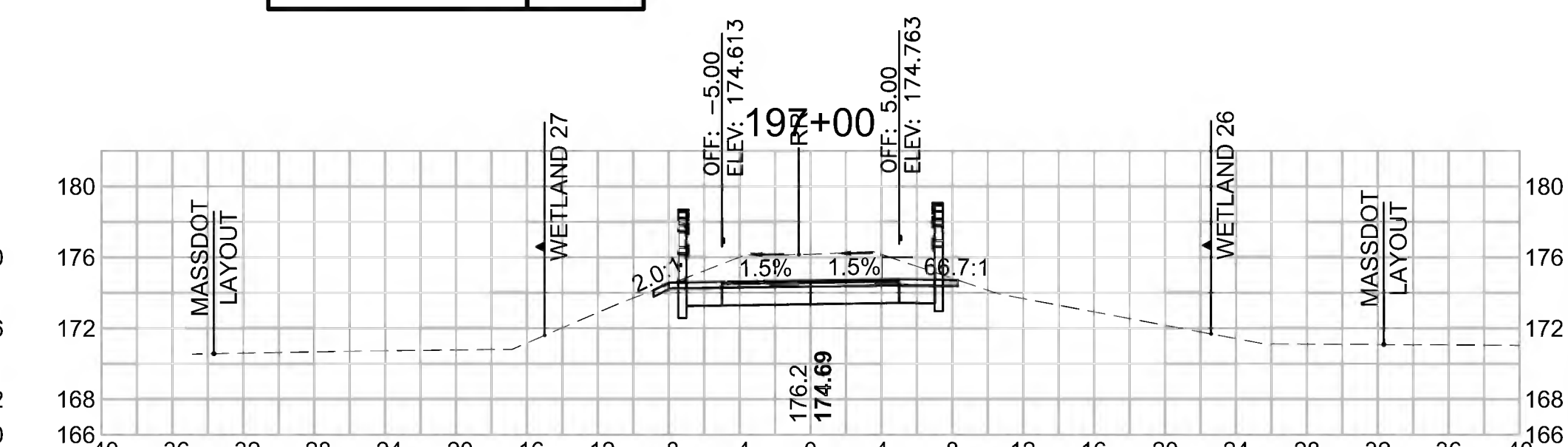

SUDBURY
BRUCE FREEMAN RAIL TRAIL

STATE	FED. AID PROJ. NO.	SHEET NO.	TOTAL SHEETS
MA	XXX-XXXX(XXX)X	268	319

PROJECT FILE NO. 608164

CROSS SECTIONS

608164_XSEC(CROSS SECTION LAYOUTS).DWG 18-Feb-2022

Total Volume at Station 199+50.00	
Cut Area (SF)	28.820
Fill Area (SF)	0.000
Cut Vol (CF)	52.5
Fill Vol (CF)	0.1
Cum Cut Vol (CF)	5712.9
Cum Fill Vol (CF)	4192.2
Net Vol (CF)	1520.6

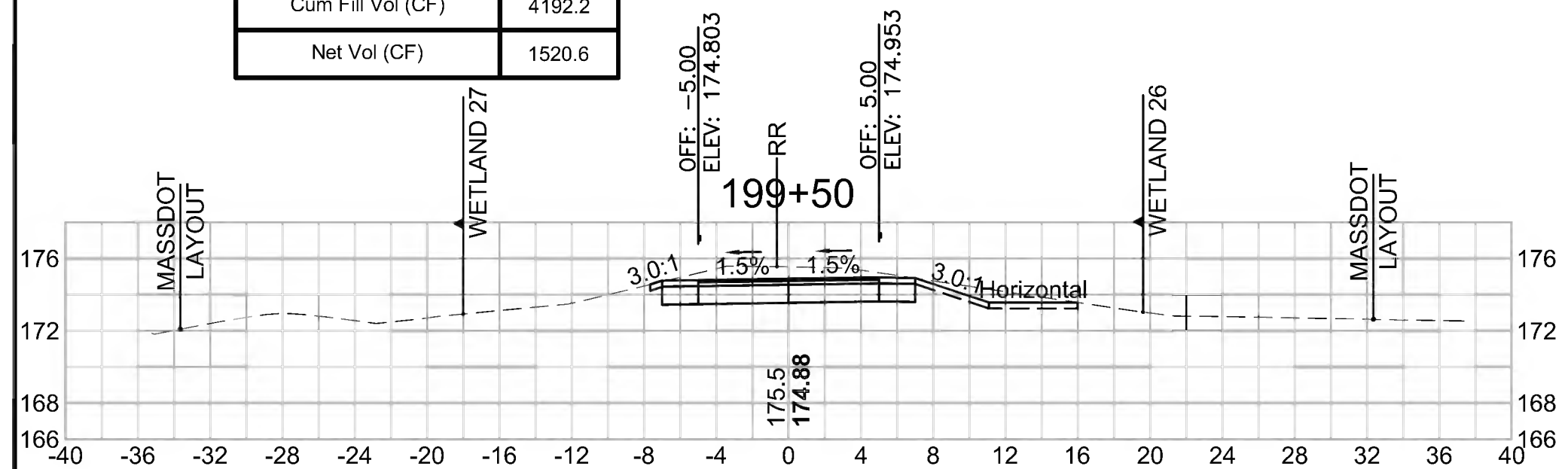

Total Volume at Station 201+00.00	
Cut Area (SF)	0.342
Fill Area (SF)	18.524
Cut Vol (CF)	6.7
Fill Vol (CF)	20.8
Cum Cut Vol (CF)	5794.2
Cum Fill Vol (CF)	4218.3
Net Vol (CF)	1575.9

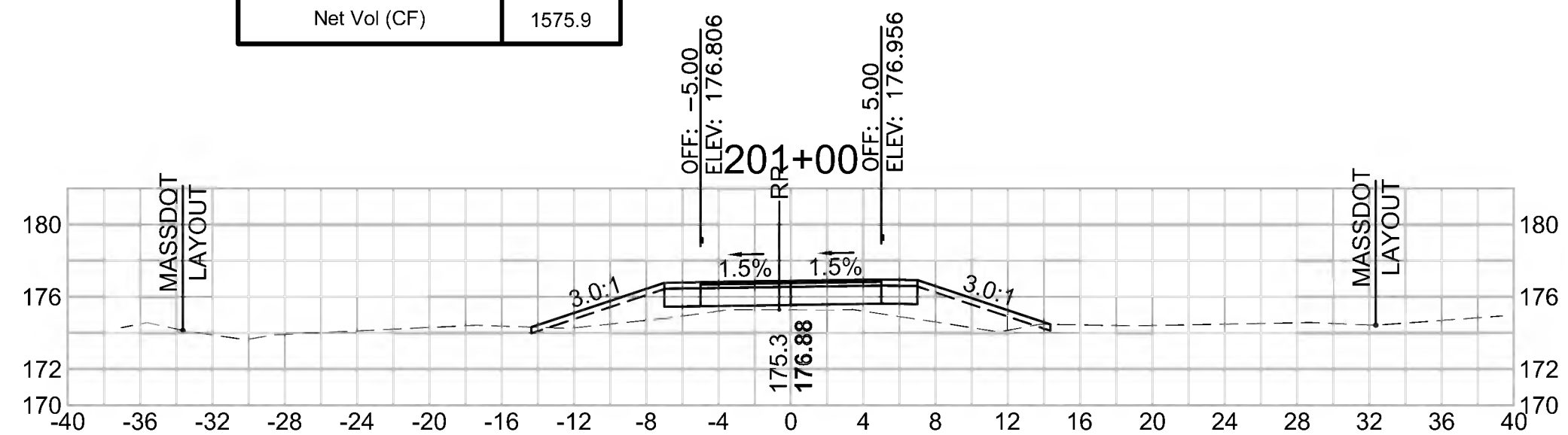

Total Volume at Station 202+50.00	
Cut Area (SF)	0.271
Fill Area (SF)	40.025
Cut Vol (CF)	0.5
Fill Vol (CF)	76.3
Cum Cut Vol (CF)	5795.9
Cum Fill Vol (CF)	4423.8
Net Vol (CF)	1372.0

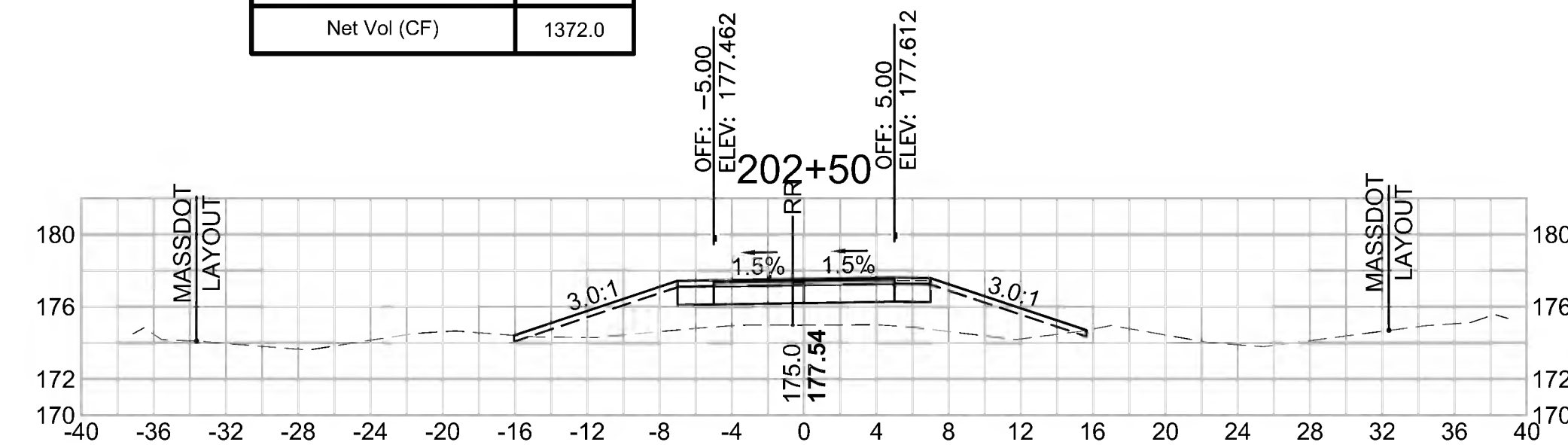

Total Volume at Station 199+00.00	
Cut Area (SF)	27.859
Fill Area (SF)	0.092
Cut Vol (CF)	53.9
Fill Vol (CF)	0.3
Cum Cut Vol (CF)	5660.4
Cum Fill Vol (CF)	4192.1
Net Vol (CF)	1468.2

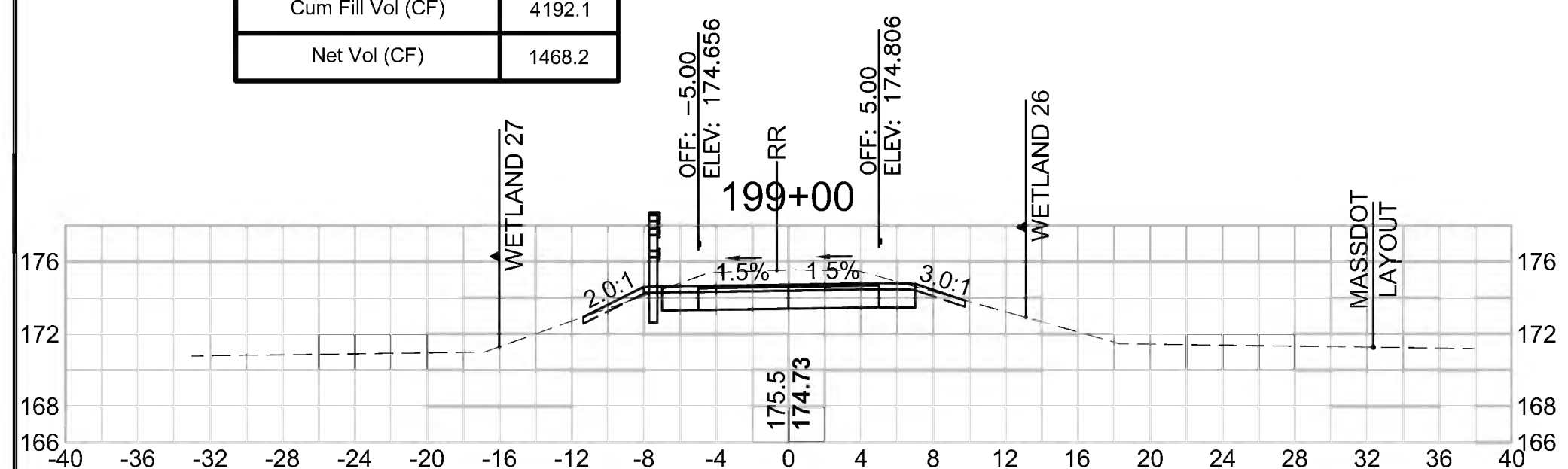

Total Volume at Station 200+50.00	
Cut Area (SF)	6.947
Fill Area (SF)	3.966
Cut Vol (CF)	27.2
Fill Vol (CF)	4.5
Cum Cut Vol (CF)	5787.5
Cum Fill Vol (CF)	4197.5
Net Vol (CF)	1590.0

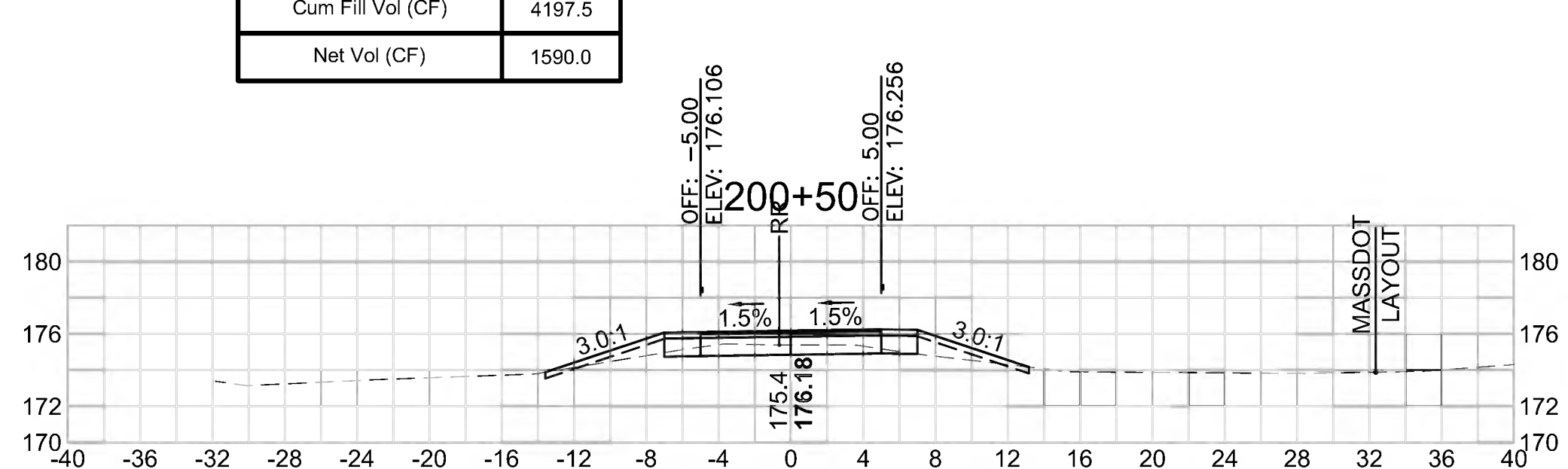

Total Volume at Station 202+00.00	
Cut Area (SF)	0.293
Fill Area (SF)	42.344
Cut Vol (CF)	0.5
Fill Vol (CF)	75.6
Cum Cut Vol (CF)	5795.3
Cum Fill Vol (CF)	4347.6
Net Vol (CF)	1447.8

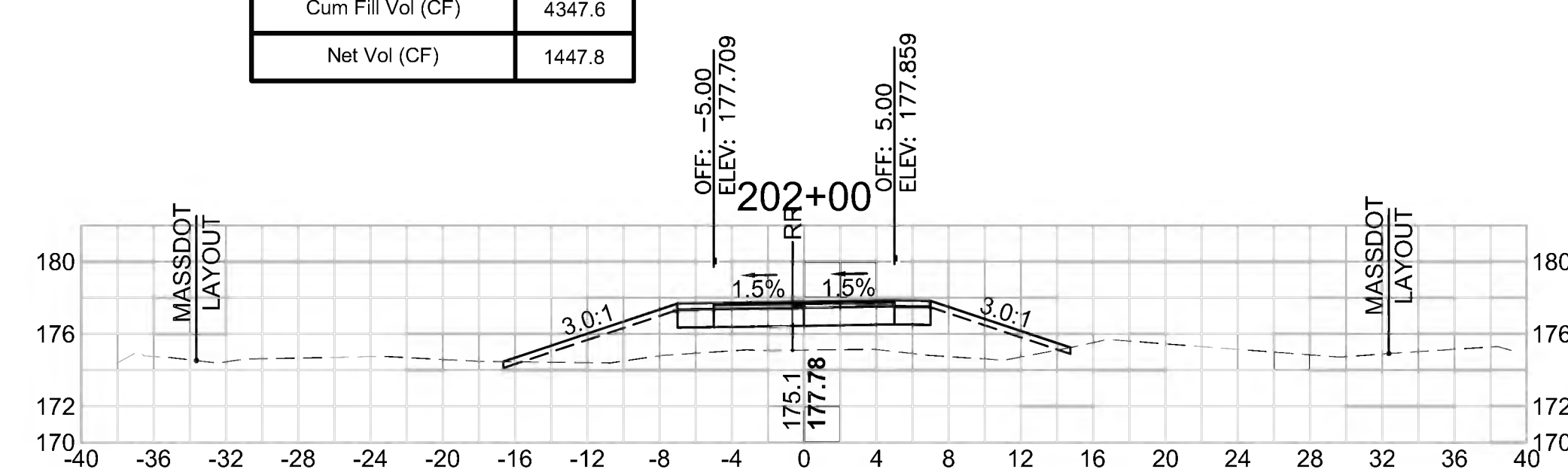

Total Volume at Station 198+50.00	
Cut Area (SF)	30.312
Fill Area (SF)	0.190
Cut Vol (CF)	57.9
Fill Vol (CF)	0.2
Cum Cut Vol (CF)	5606.5
Cum Fill Vol (CF)	4191.9
Net Vol (CF)	1414.6

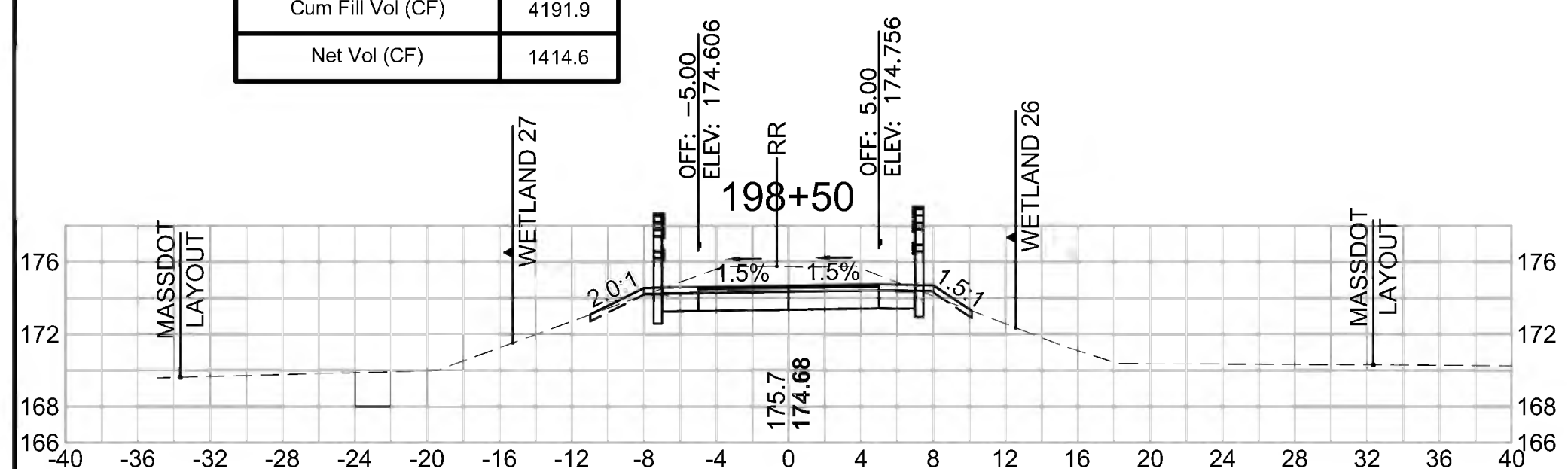

Total Volume at Station 200+00.00	
Cut Area (SF)	22.409
Fill Area (SF)	0.868
Cut Vol (CF)	47.4
Fill Vol (CF)	0.8
Cum Cut Vol (CF)	5760.3
Cum Fill Vol (CF)	4193.0
Net Vol (CF)	1567.3

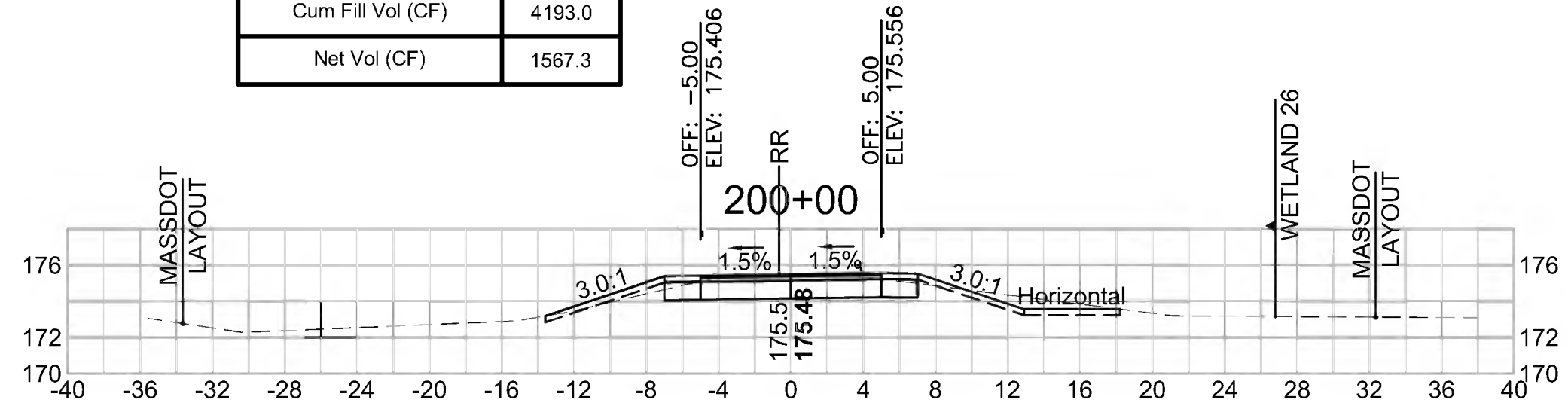

Total Volume at Station 201+50.00	
Cut Area (SF)	0.275
Fill Area (SF)	39.345
Cut Vol (CF)	0.6
Fill Vol (CF)	53.6
Cum Cut Vol (CF)	5794.8
Cum Fill Vol (CF)	4271.9
Net Vol (CF)	1522.9

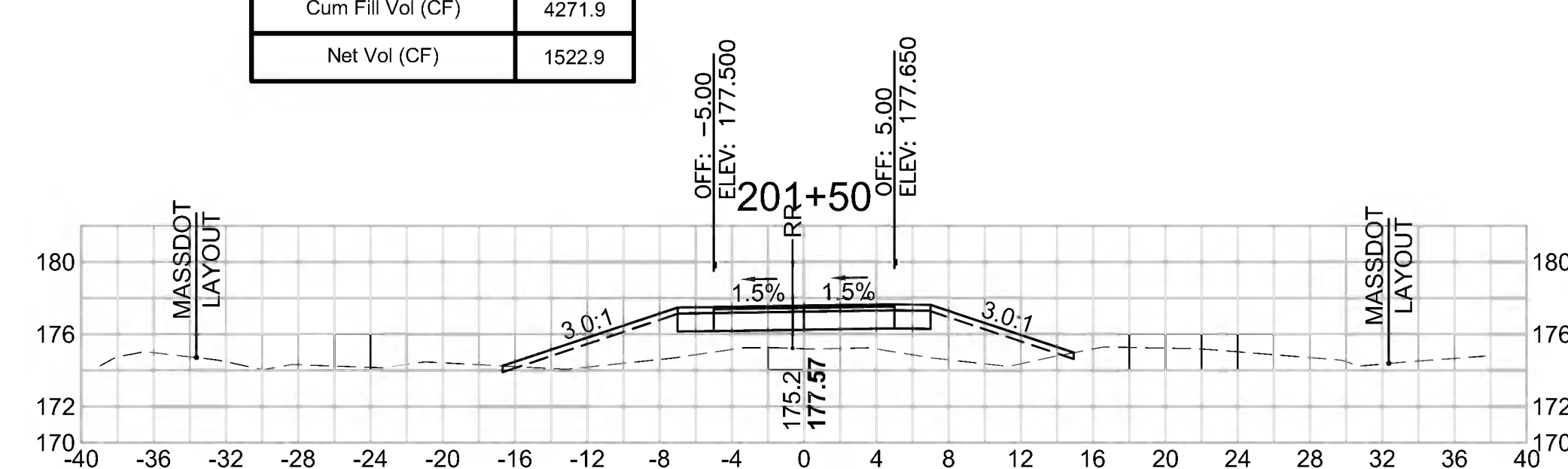

SUDBURY
BRUCE FREEMAN RAIL TRAIL

STATE	FED. AID PROJ. NO.	SHEET NO.	TOTAL SHEETS
MA	XXX-XXXX(XXX)X	269	319

CROSS SECTIONS

Total Volume at Station 204+00.00	
Cut Area (SF)	0.258
Fill Area (SF)	28.304
Cut Vol (CF)	0.5
Fill Vol (CF)	56.4
Cum Cut Vol (CF)	5797.6
Cum Fill Vol (CF)	4615.8
Net Vol (CF)	1181.9

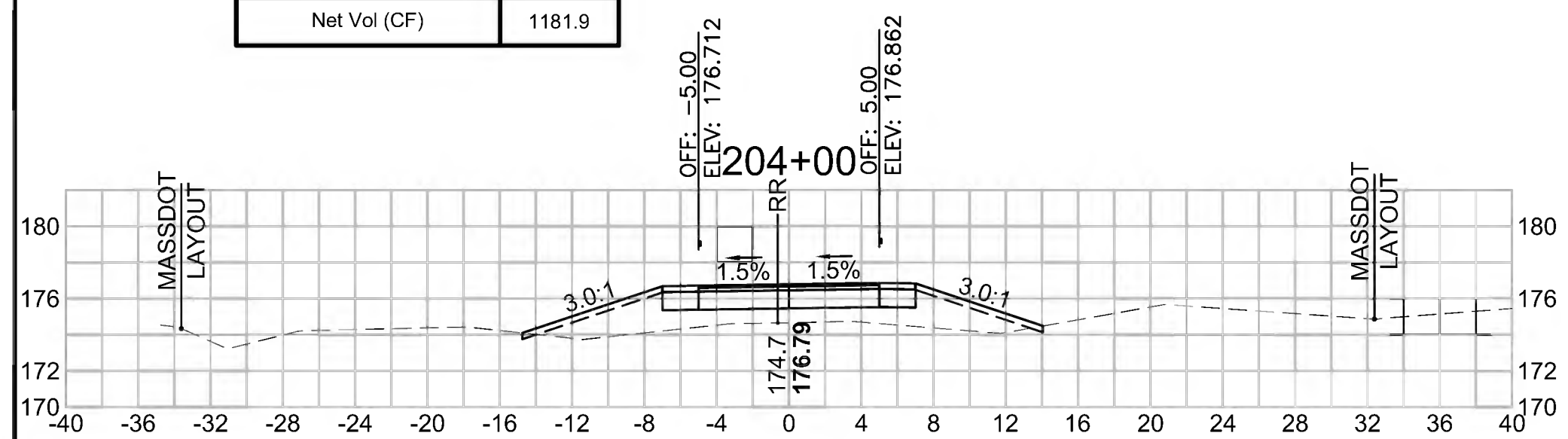

Total Volume at Station 205+50.00	
Cut Area (SF)	0.375
Fill Area (SF)	21.699
Cut Vol (CF)	0.7
Fill Vol (CF)	41.8
Cum Cut Vol (CF)	5799.4
Cum Fill Vol (CF)	4757.7
Net Vol (CF)	1041.7

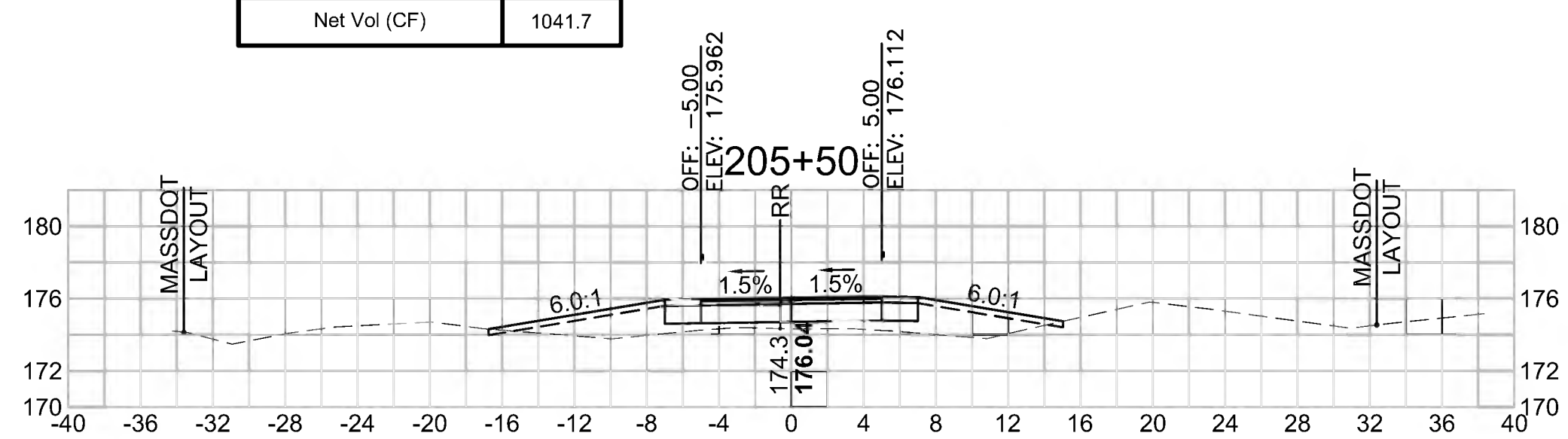

Total Volume at Station 207+00.00	
Cut Area (SF)	0.486
Fill Area (SF)	13.526
Cut Vol (CF)	0.8
Fill Vol (CF)	23.9
Cum Cut Vol (CF)	5801.5
Cum Fill Vol (CF)	4840.4
Net Vol (CF)	961.2

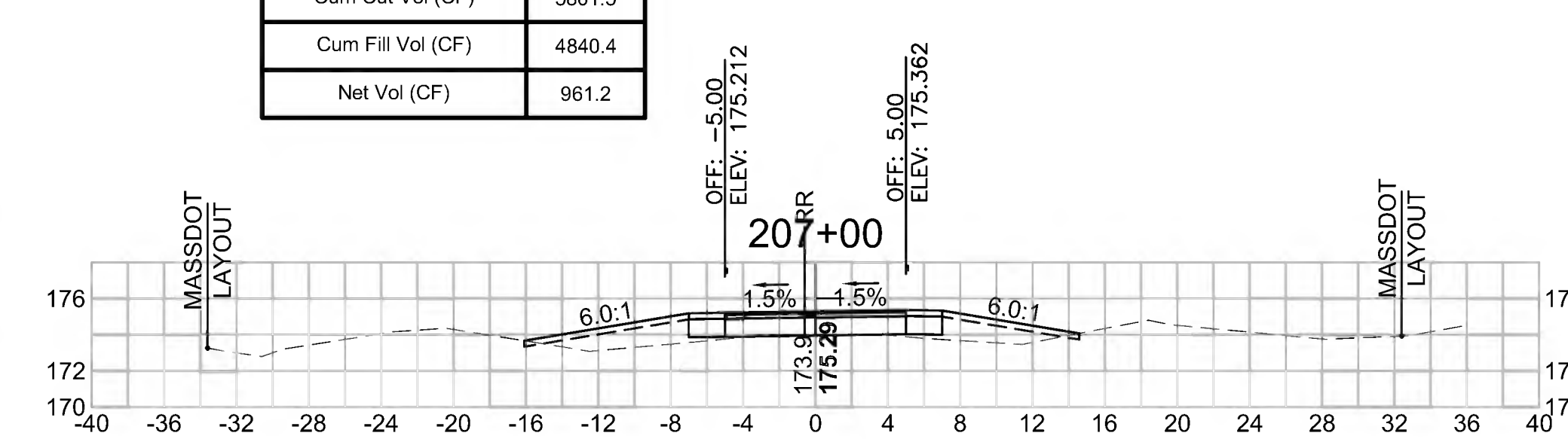

Total Volume at Station 203+50.00	
Cut Area (SF)	0.272
Fill Area (SF)	32.630
Cut Vol (CF)	0.6
Fill Vol (CF)	64.3
Cum Cut Vol (CF)	5797.1
Cum Fill Vol (CF)	4559.3
Net Vol (CF)	1237.8

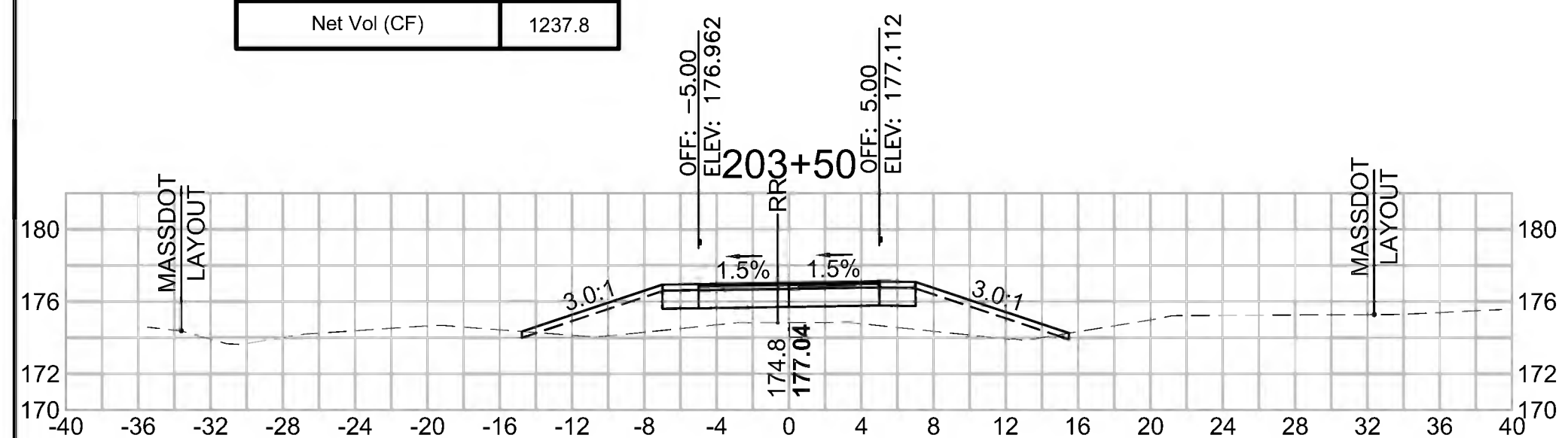

Total Volume at Station 205+00.00	
Cut Area (SF)	0.335
Fill Area (SF)	23.445
Cut Vol (CF)	0.6
Fill Vol (CF)	47.8
Cum Cut Vol (CF)	5798.7
Cum Fill Vol (CF)	4715.9
Net Vol (CF)	1082.8

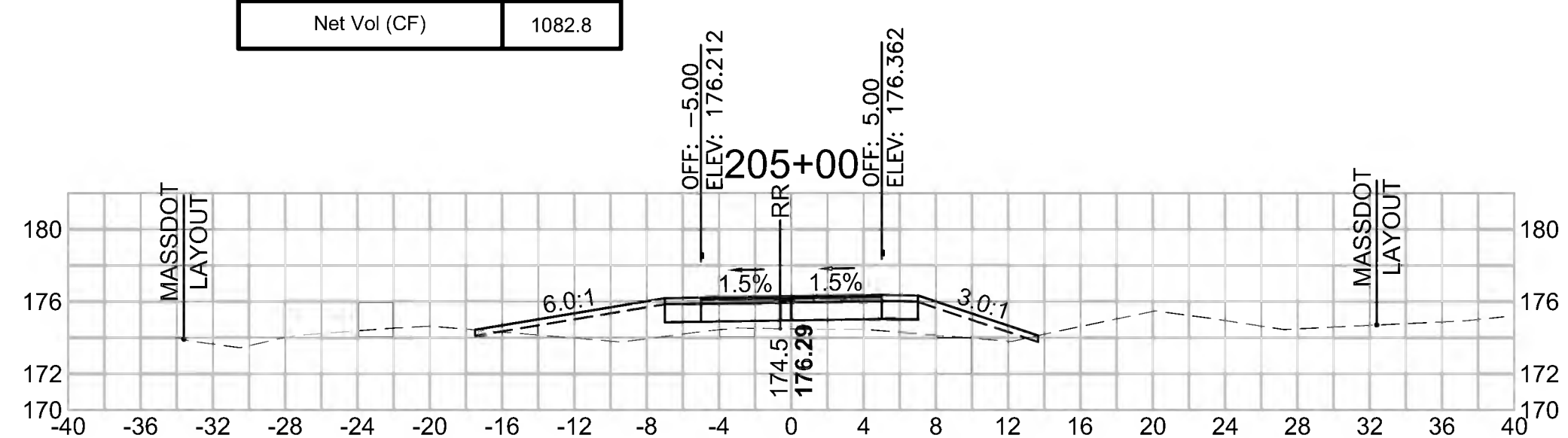

Total Volume at Station 206+50.00	
Cut Area (SF)	0.406
Fill Area (SF)	12.314
Cut Vol (CF)	0.7
Fill Vol (CF)	25.0
Cum Cut Vol (CF)	5800.7
Cum Fill Vol (CF)	4816.4
Net Vol (CF)	984.3

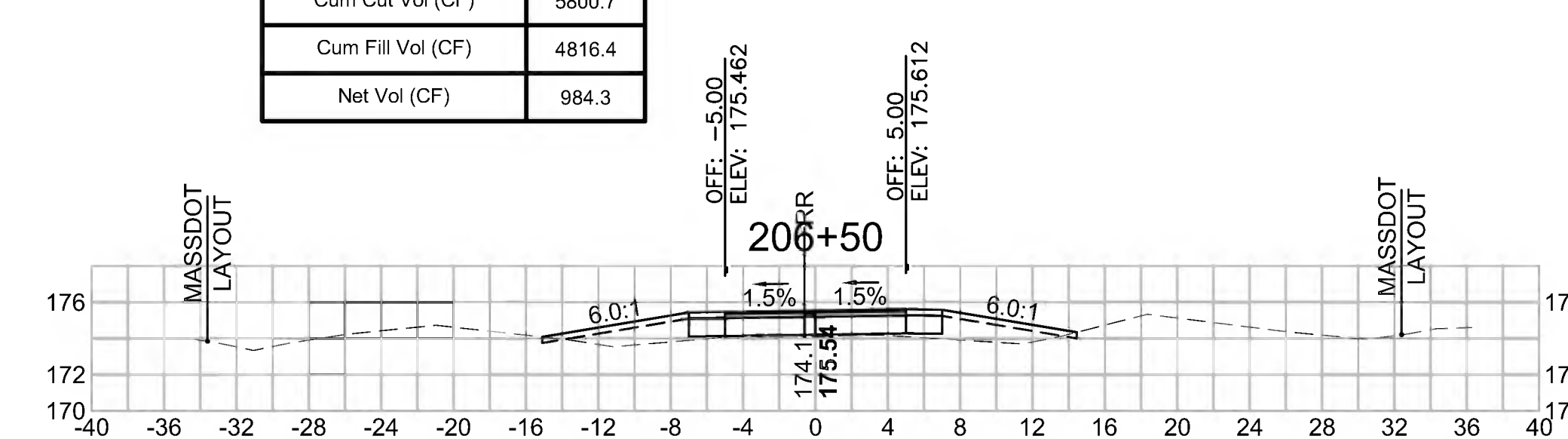

Total Volume at Station 203+00.00	
Cut Area (SF)	0.424
Fill Area (SF)	36.854
Cut Vol (CF)	0.6
Fill Vol (CF)	71.2
Cum Cut Vol (CF)	5796.5
Cum Fill Vol (CF)	4495.0
Net Vol (CF)	1301.5

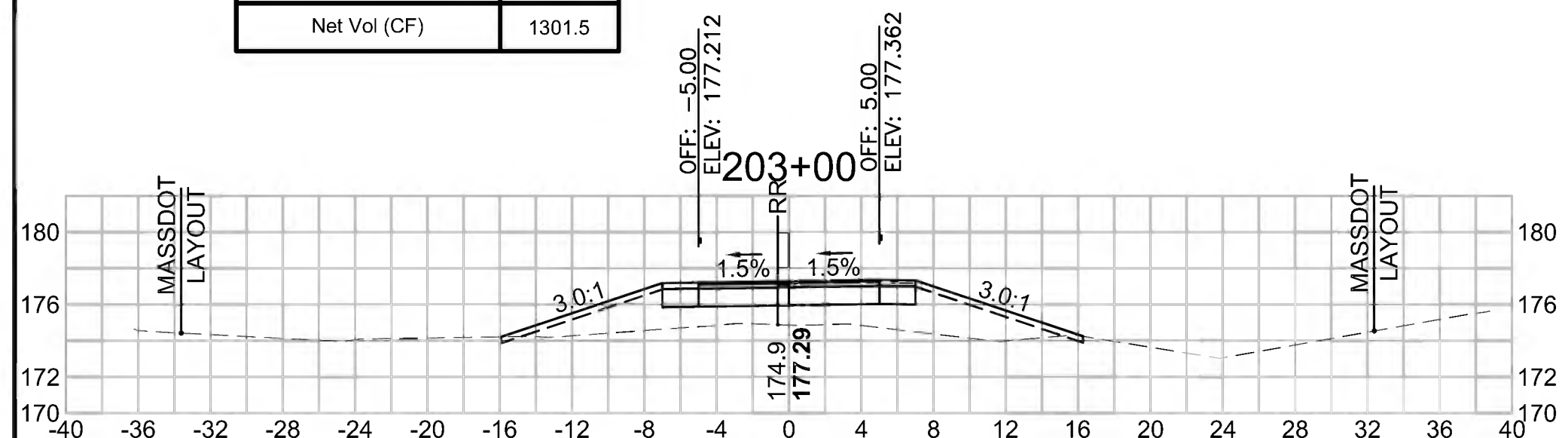

Total Volume at Station 204+50.00	
Cut Area (SF)	0.298
Fill Area (SF)	28.213
Cut Vol (CF)	0.5
Fill Vol (CF)	52.3
Cum Cut Vol (CF)	5798.1
Cum Fill Vol (CF)	4668.1
Net Vol (CF)	1130.1

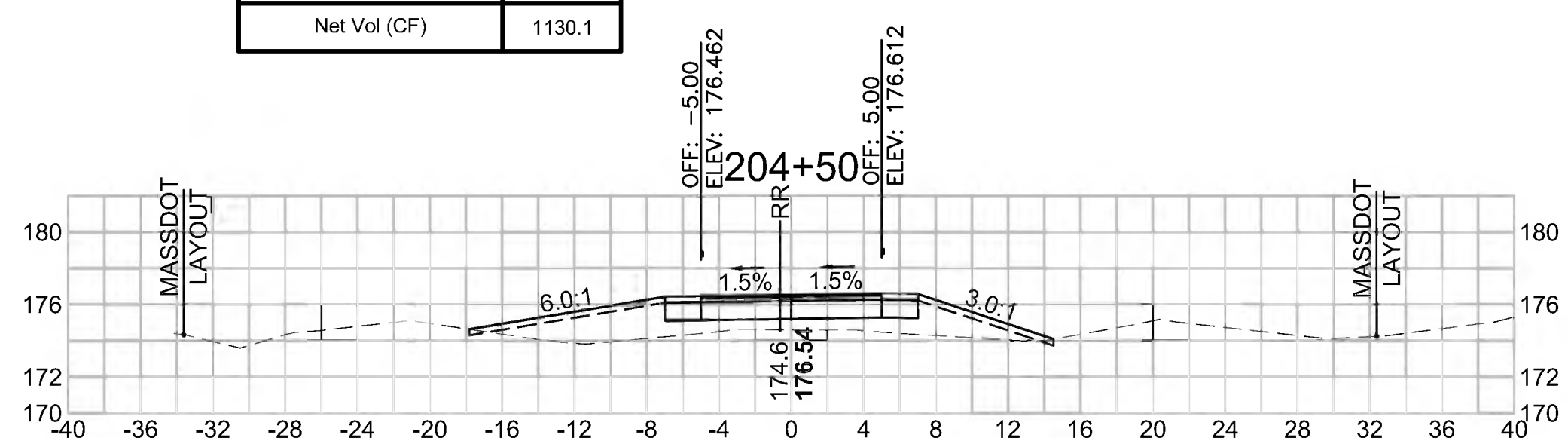

Total Volume at Station 206+00.00	
Cut Area (SF)	0.331
Fill Area (SF)	14.701
Cut Vol (CF)	0.7
Fill Vol (CF)	33.7
Cum Cut Vol (CF)	5800.0
Cum Fill Vol (CF)	4791.4
Net Vol (CF)	1008.6

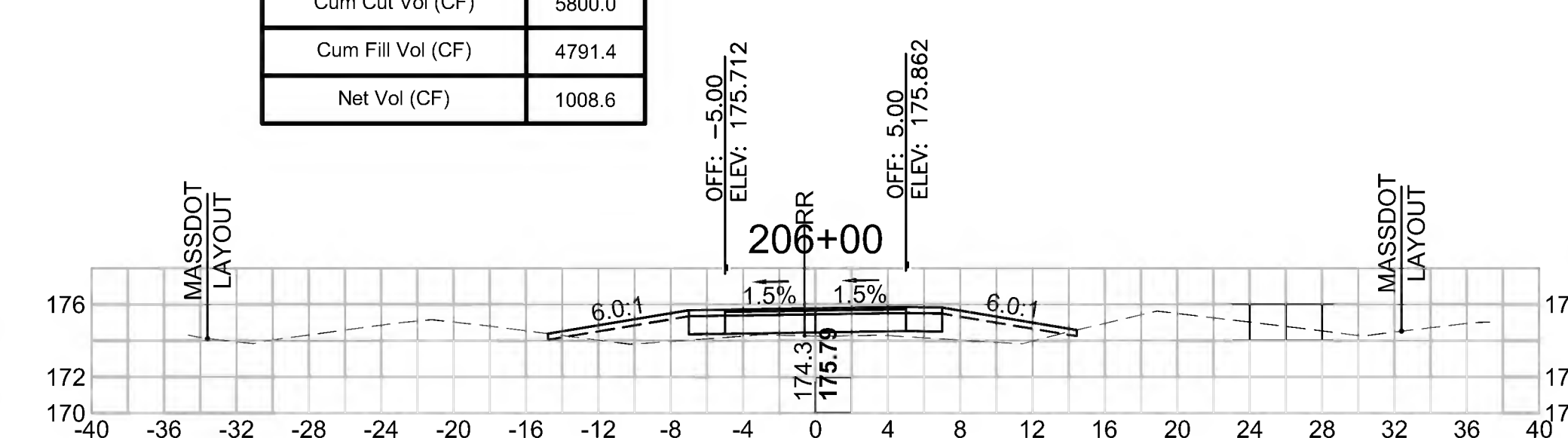

SUDBURY
BRUCE FREEMAN RAIL TRAIL

STATE	FED. AID PROJ. NO.	SHEET NO.	TOTAL SHEETS
MA	XXX-XXXX(XXX)X	270	319
PROJECT FILE NO. 608164			

CROSS SECTIONS

608164_XSEC(CROSS SECTION LAYOUTS).DWG 18-Feb-2022

Total Volume at Station 208+50.00	
Cut Area (SF)	9.191
Fill Area (SF)	2.229
Cut Vol (CF)	11.7
Fill Vol (CF)	8.2
Cum Cut Vol (CF)	5818.5
Cum Fill Vol (CF)	4887.7
Net Vol (CF)	930.8

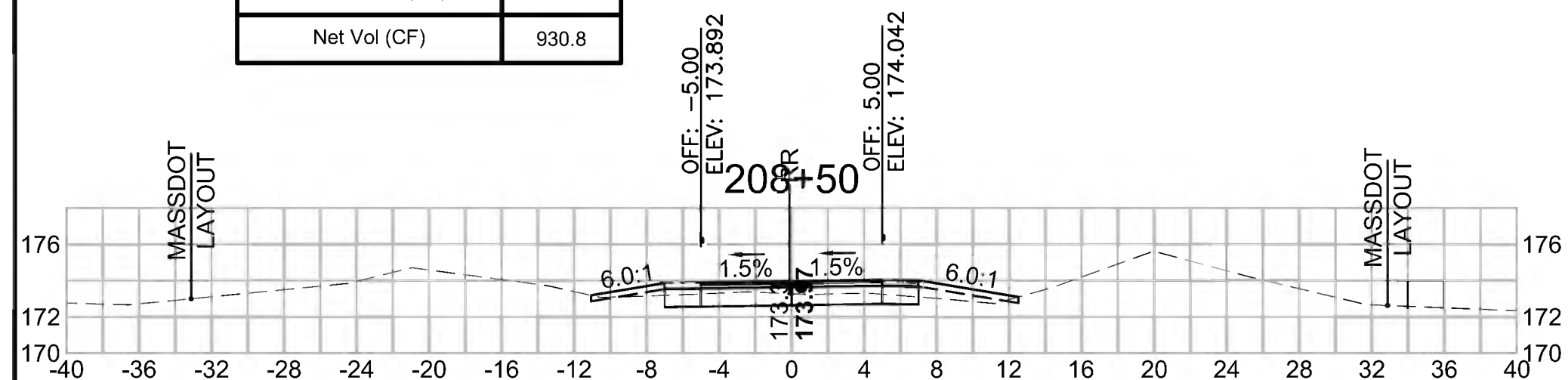

Total Volume at Station 210+00.00	
Cut Area (SF)	21.922
Fill Area (SF)	0.211
Cut Vol (CF)	37.4
Fill Vol (CF)	0.2
Cum Cut Vol (CF)	5908.0
Cum Fill Vol (CF)	4890.6
Net Vol (CF)	1017.4

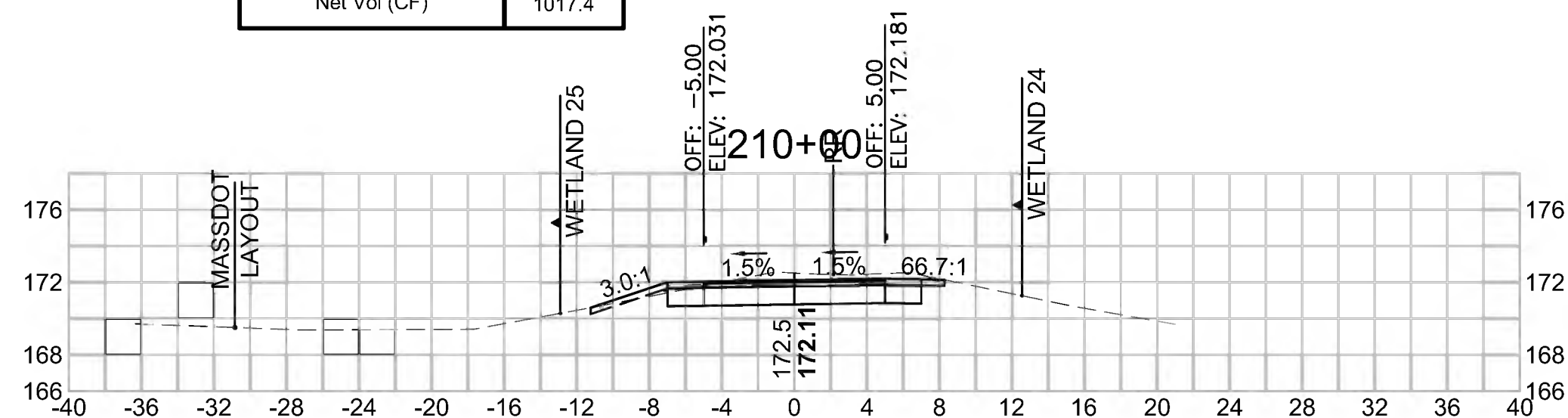

Total Volume at Station 211+50.00	
Cut Area (SF)	18.770
Fill Area (SF)	0.179
Cut Vol (CF)	38.1
Fill Vol (CF)	0.3
Cum Cut Vol (CF)	6030.3
Cum Fill Vol (CF)	4891.4
Net Vol (CF)	1138.9

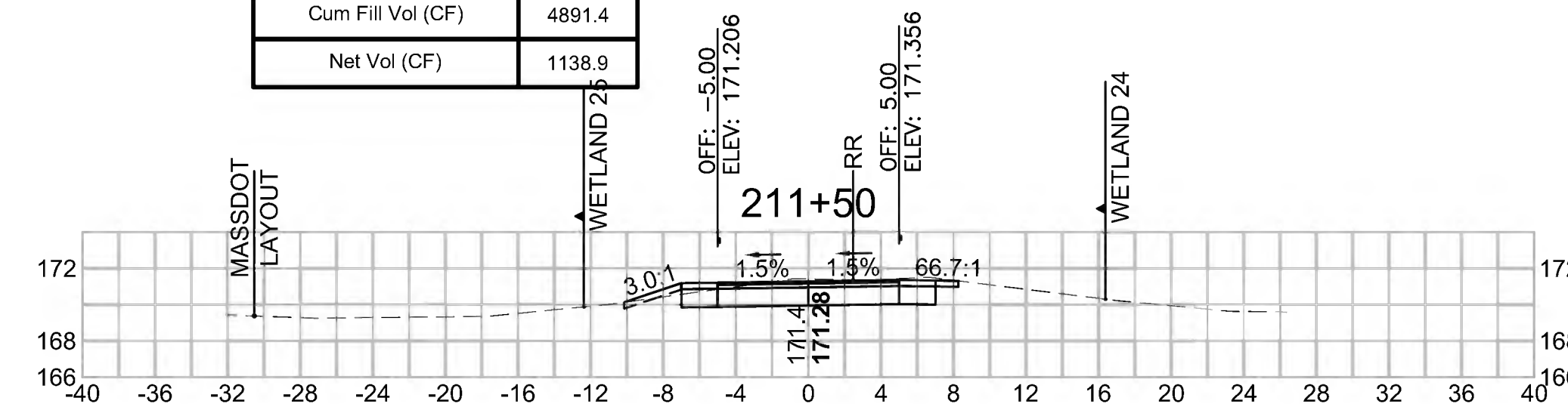

Total Volume at Station 208+00.00	
Cut Area (SF)	3.446
Fill Area (SF)	6.676
Cut Vol (CF)	4.0
Fill Vol (CF)	16.4
Cum Cut Vol (CF)	5806.8
Cum Fill Vol (CF)	4879.5
Net Vol (CF)	927.4

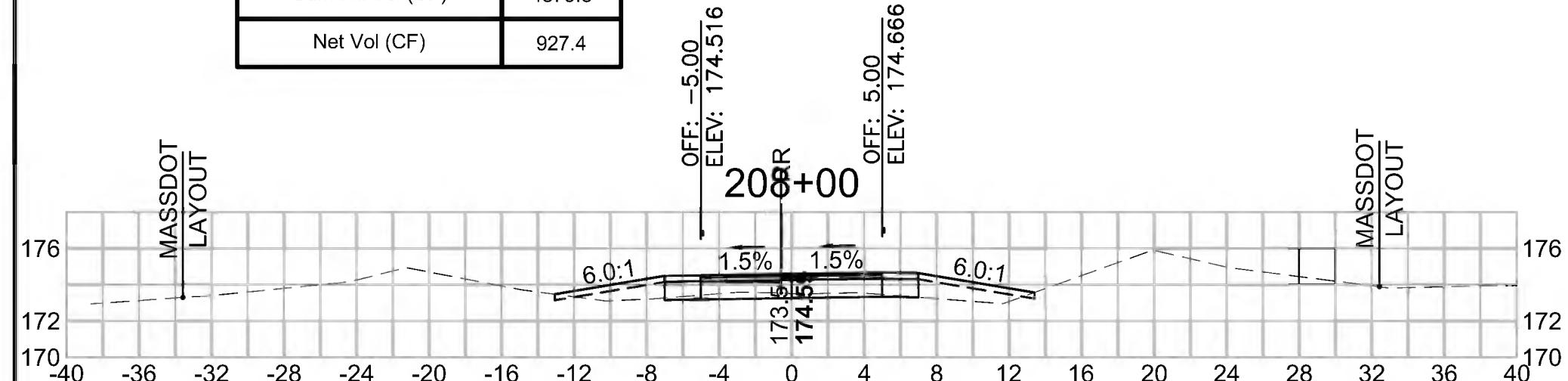

Total Volume at Station 209+50.00	
Cut Area (SF)	18.433
Fill Area (SF)	0.029
Cut Vol (CF)	30.3
Fill Vol (CF)	0.3
Cum Cut Vol (CF)	5870.6
Cum Fill Vol (CF)	4890.4
Net Vol (CF)	980.3

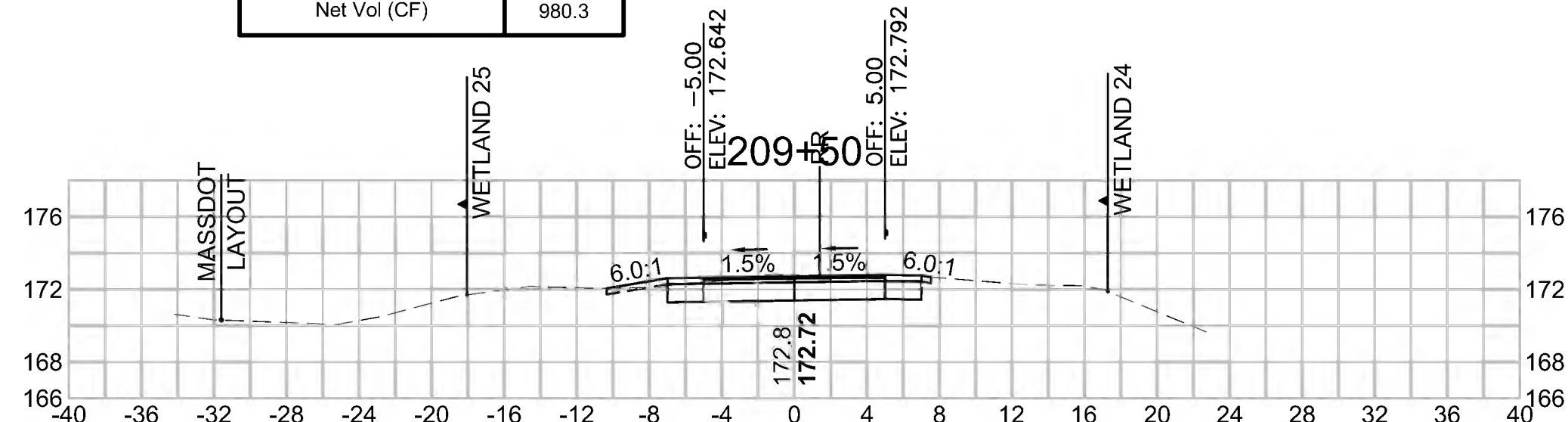

Total Volume at Station 211+00.00	
Cut Area (SF)	22.329
Fill Area (SF)	0.185
Cut Vol (CF)	42.3
Fill Vol (CF)	0.2
Cum Cut Vol (CF)	5992.2
Cum Fill Vol (CF)	4891.1
Net Vol (CF)	1101.2

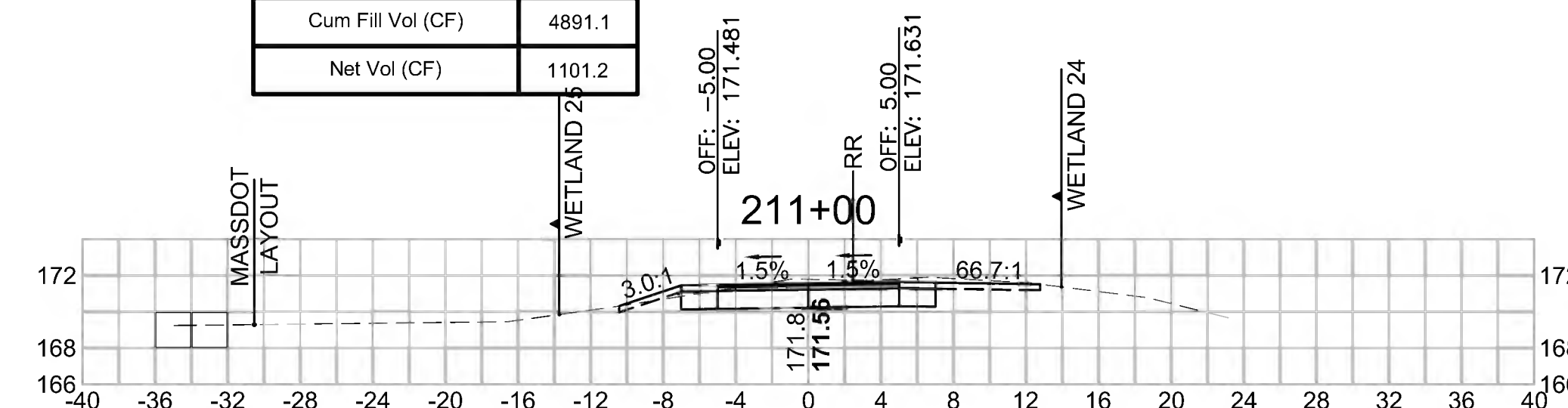

Total Volume at Station 207+50.00	
Cut Area (SF)	0.895
Fill Area (SF)	11.006
Cut Vol (CF)	1.3
Fill Vol (CF)	22.7
Cum Cut Vol (CF)	5802.8
Cum Fill Vol (CF)	4863.1
Net Vol (CF)	939.7

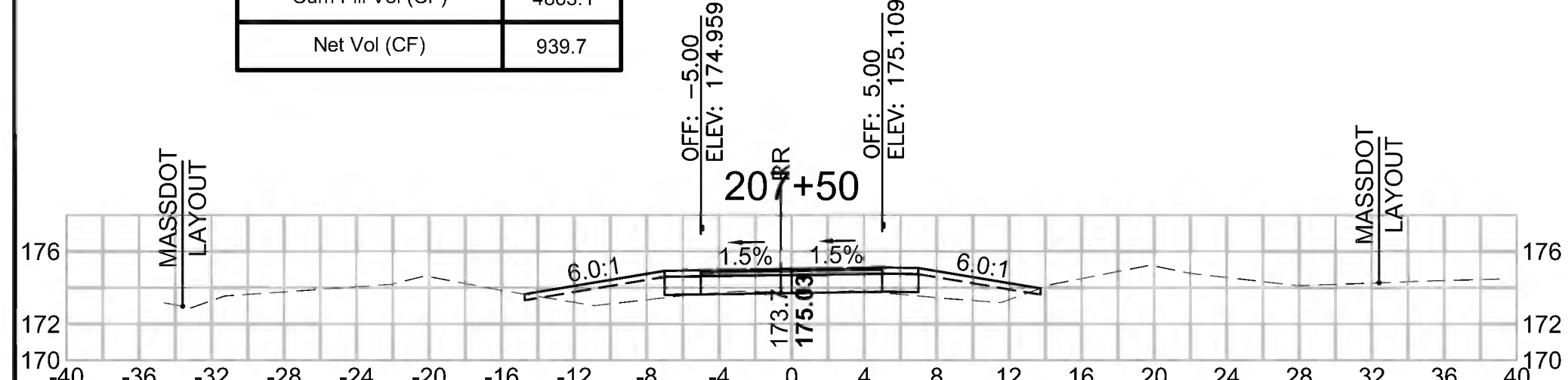

Total Volume at Station 209+00.00	
Cut Area (SF)	14.314
Fill Area (SF)	0.317
Cut Vol (CF)	21.8
Fill Vol (CF)	2.4
Cum Cut Vol (CF)	5840.3
Cum Fill Vol (CF)	4890.1
Net Vol (CF)	950.3

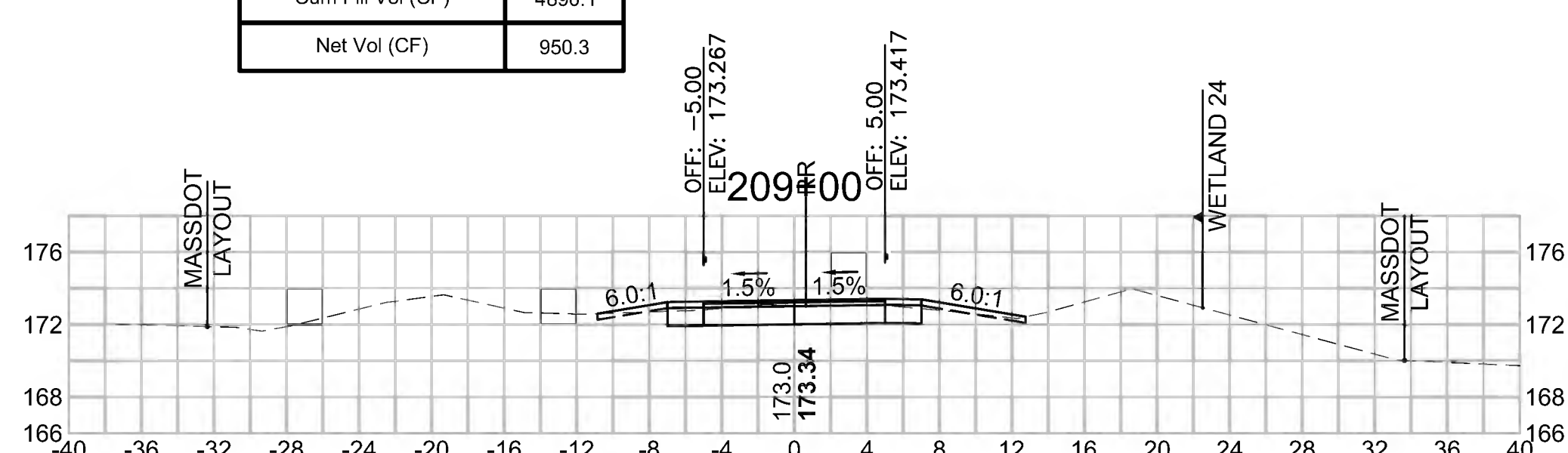

Total Volume at Station 210+50.00	
Cut Area (SF)	23.362
Fill Area (SF)	0.053
Cut Vol (CF)	41.9
Fill Vol (CF)	0.2
Cum Cut Vol (CF)	5949.9
Cum Fill Vol (CF)	4890.8
Net Vol (CF)	1059.1

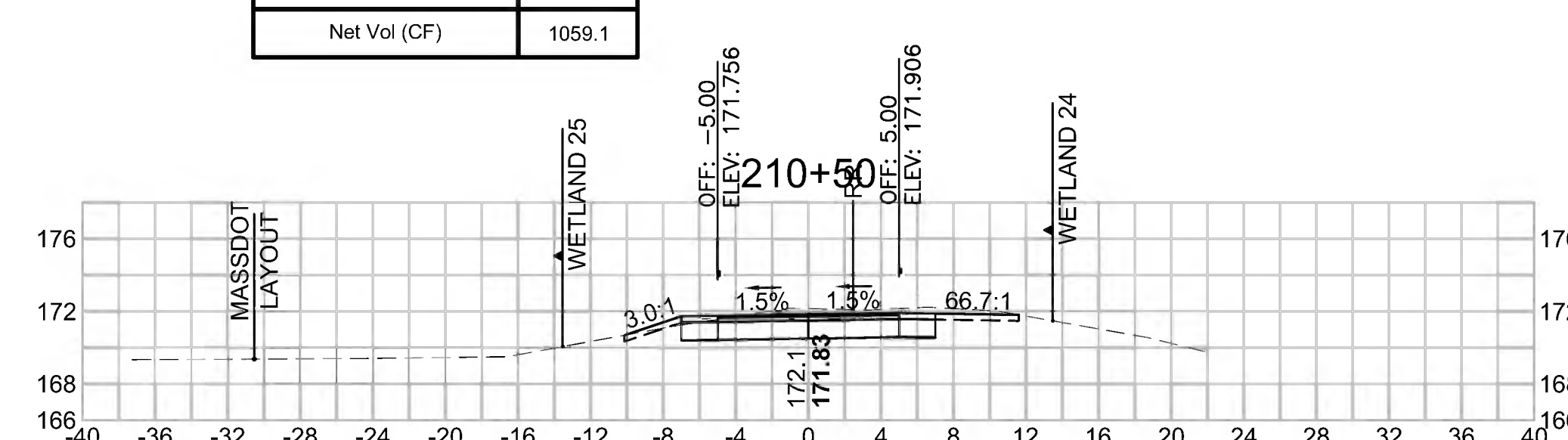

SUDBURY
BRUCE FREEMAN RAIL TRAIL

STATE	FED. AID PROJ. NO.	SHEET NO.	TOTAL SHEETS
MA	XXX-XXX(XXX)X	271	319

PROJECT FILE NO. 608164

CROSS SECTIONS

Total Volume at Station 213+00.00

Cut Area (SF)	14.065
Fill Area (SF)	0.000
Cut Vol (CF)	28.4
Fill Vol (CF)	0.0
Cum Cut Vol (CF)	6124.6
Cum Fill Vol (CF)	4891.6
Net Vol (CF)	1233.0

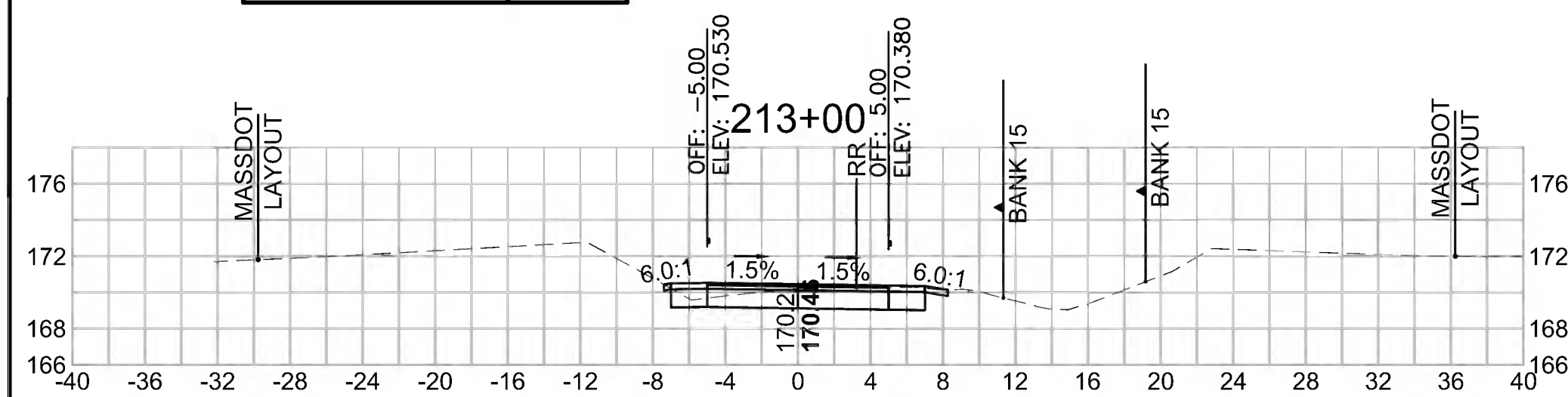

Total Volume at Station 214+50.00

Cut Area (SF)	14.677
Fill Area (SF)	0.356
Cut Vol (CF)	33.4
Fill Vol (CF)	0.3
Cum Cut Vol (CF)	6225.6
Cum Fill Vol (CF)	4891.9
Net Vol (CF)	1333.7

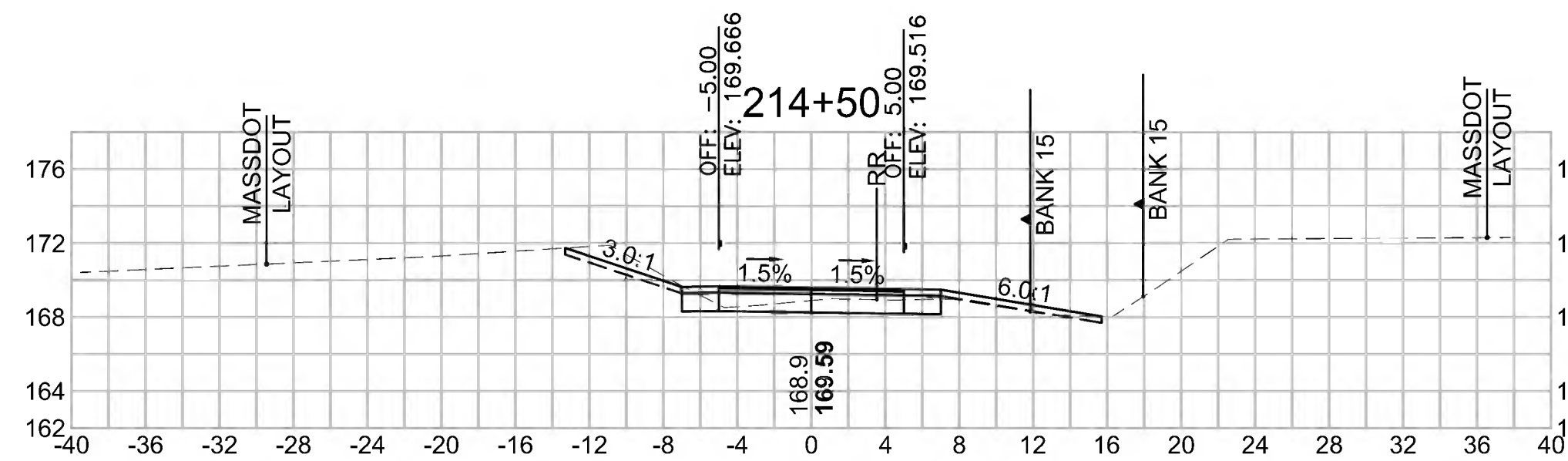

Total Volume at Station 216+00.00

Cut Area (SF)	24.110
Fill Area (SF)	0.000
Cut Vol (CF)	30.6
Fill Vol (CF)	0.1
Cum Cut Vol (CF)	6292.3
Cum Fill Vol (CF)	4892.7
Net Vol (CF)	1399.6

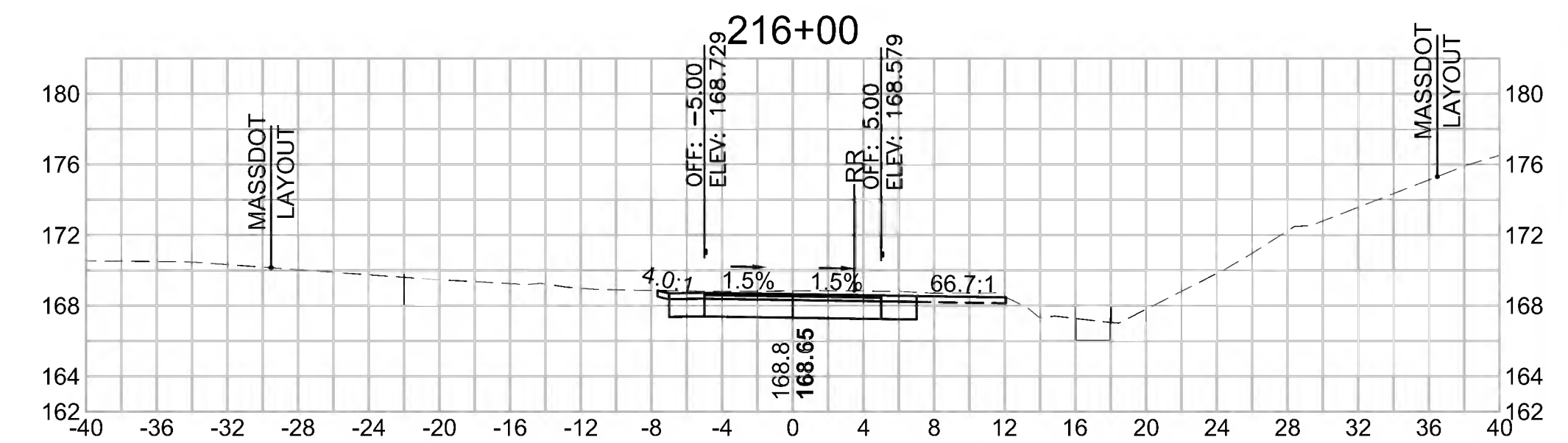

Total Volume at Station 212+50.00

Cut Area (SF)	16.643
Fill Area (SF)	0.000
Cut Vol (CF)	32.0
Fill Vol (CF)	0.0
Cum Cut Vol (CF)	6096.2
Cum Fill Vol (CF)	4891.6
Net Vol (CF)	1204.6

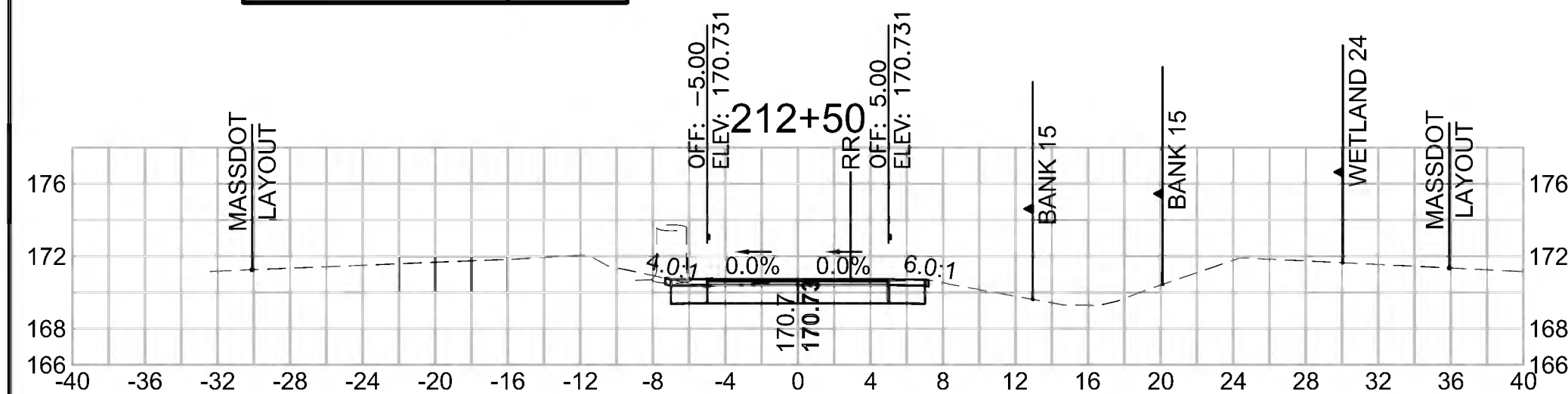

Total Volume at Station 214+00.00

Cut Area (SF)	21.365
Fill Area (SF)	0.000
Cut Vol (CF)	37.2
Fill Vol (CF)	0.0
Cum Cut Vol (CF)	6192.2
Cum Fill Vol (CF)	4891.6
Net Vol (CF)	1300.6

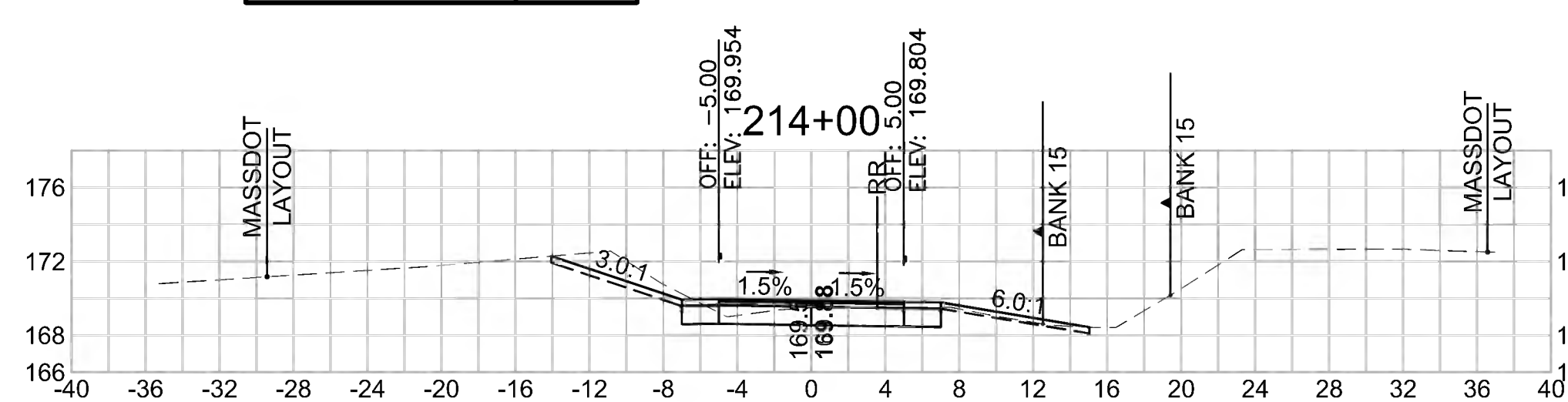

Total Volume at Station 215+50.00

Cut Area (SF)	8.933
Fill Area (SF)	0.083
Cut Vol (CF)	15.4
Fill Vol (CF)	0.2
Cum Cut Vol (CF)	6261.7
Cum Fill Vol (CF)	4892.6
Net Vol (CF)	1369.1

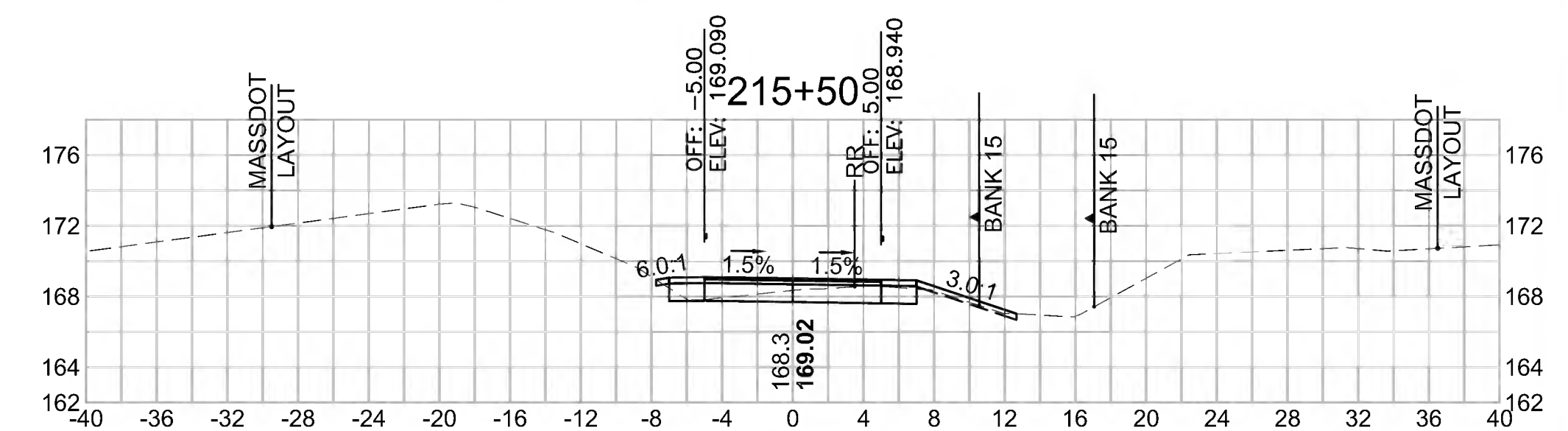

Total Volume at Station 212+00.00

Cut Area (SF)	17.865
Fill Area (SF)	0.014
Cut Vol (CF)	33.9
Fill Vol (CF)	0.2
Cum Cut Vol (CF)	6064.2
Cum Fill Vol (CF)	4891.6
Net Vol (CF)	1172.6

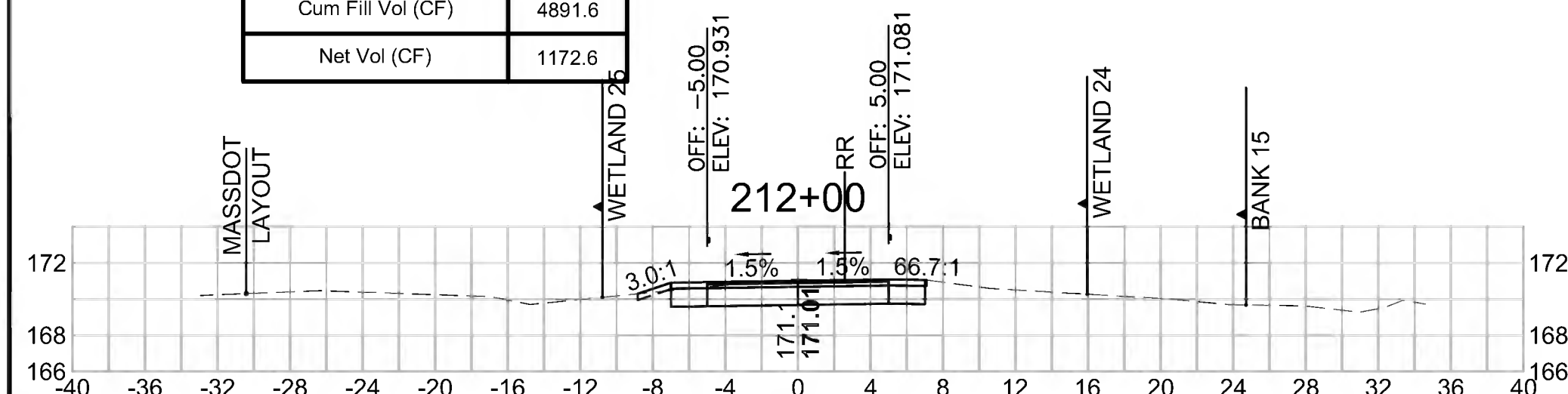

Total Volume at Station 213+50.00

Cut Area (SF)	18.793
Fill Area (SF)	0.000
Cut Vol (CF)	30.4
Fill Vol (CF)	0.0
Cum Cut Vol (CF)	6155.0
Cum Fill Vol (CF)	4891.6
Net Vol (CF)	1263.4

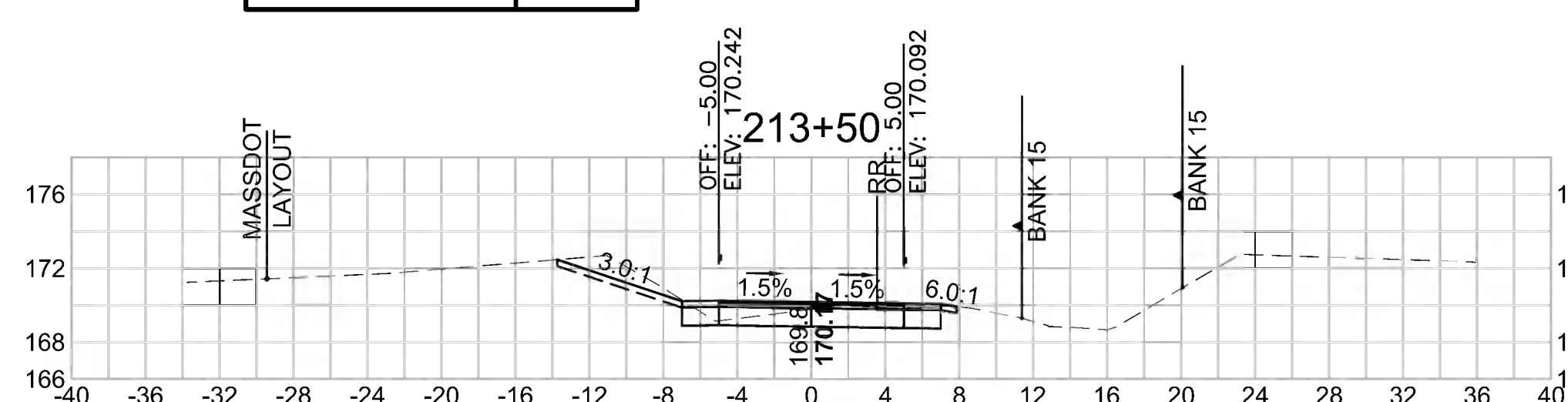

Total Volume at Station 215+00.00

Cut Area (SF)	7.704
Fill Area (SF)	0.152
Cut Vol (CF)	20.7
Fill Vol (CF)	0.5
Cum Cut Vol (CF)	6246.3
Cum Fill Vol (CF)	4892.4
Net Vol (CF)	1353.9

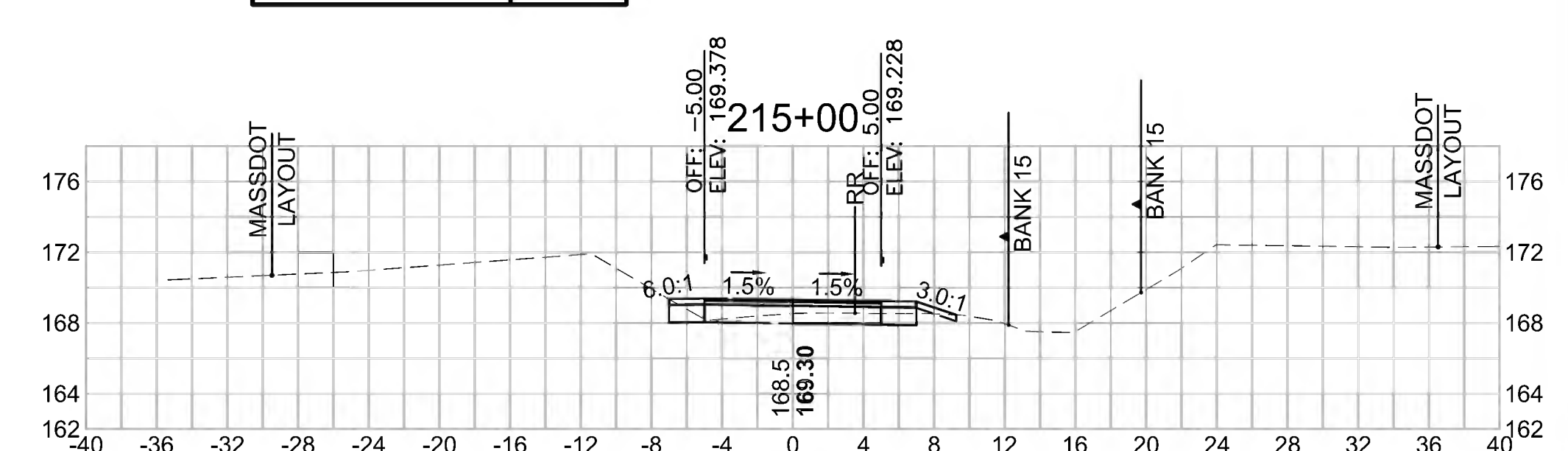

SUDBURY
BRUCE FREEMAN RAIL TRAIL

STATE	FED. AID PROJ. NO.	SHEET NO.	TOTAL SHEETS
MA	XXX-XXXX(XXX)X	272	319
PROJECT FILE NO. 608164			

CROSS SECTIONS

Total Volume at Station 217+50.00	
Cut Area (SF)	5.141
Fill Area (SF)	0.179
Cut Vol (CF)	48.7
Fill Vol (CF)	1.2
Cum Cut Vol (CF)	6417.7
Cum Fill Vol (CF)	4895.7
Net Vol (CF)	1521.9

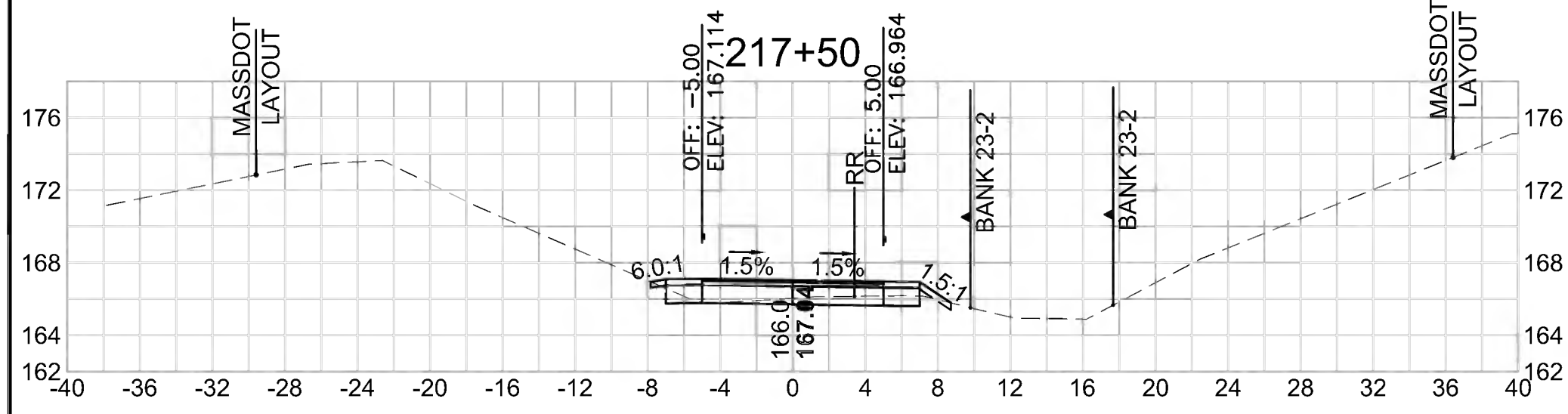

Total Volume at Station 217+00.00	
Cut Area (SF)	47.403
Fill Area (SF)	1.077
Cut Vol (CF)	49.1
Fill Vol (CF)	1.4
Cum Cut Vol (CF)	6369.0
Cum Fill Vol (CF)	4894.6
Net Vol (CF)	1474.4

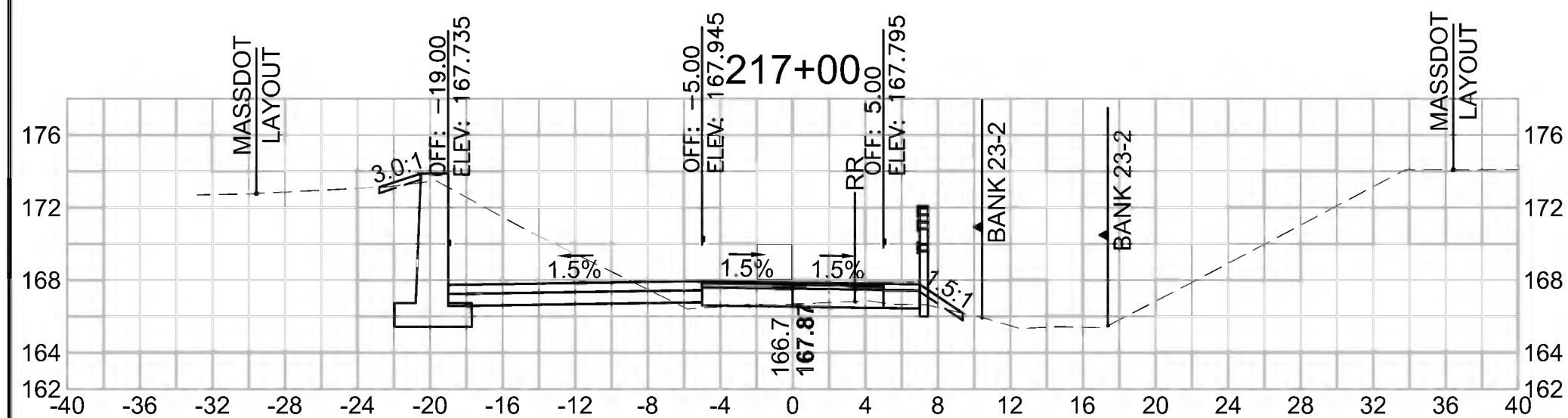

Total Volume at Station 216+50.00	
Cut Area (SF)	5.672
Fill Area (SF)	0.482
Cut Vol (CF)	27.6
Fill Vol (CF)	0.4
Cum Cut Vol (CF)	6319.9
Cum Fill Vol (CF)	4893.1
Net Vol (CF)	1426.7

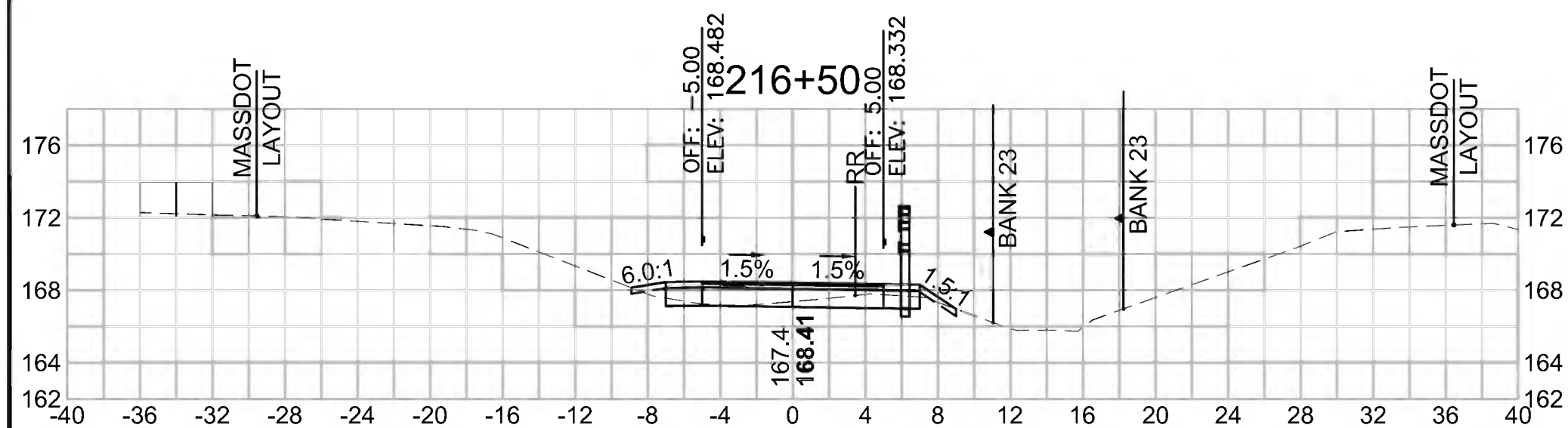

SUDBURY
BRUCE FREEMAN RAIL TRAIL

STATE	FED. AID PROJ. NO.	SHEET NO.	TOTAL SHEETS
MA	XXX-XXX(XXX)X	273	319
PROJECT FILE NO. 608164			

CROSS SECTIONS

608164_XSEC(CROSS SECTION LAYOUTS).DWG 18-Feb-2022

Total Volume at Station 219+00.00	
Cut Area (SF)	13.950
Fill Area (SF)	0.005
Cut Vol (CF)	22.5
Fill Vol (CF)	0.0
Cum Cut Vol (CF)	6463.8
Cum Fill Vol (CF)	4896.1
Net Vol (CF)	1567.7

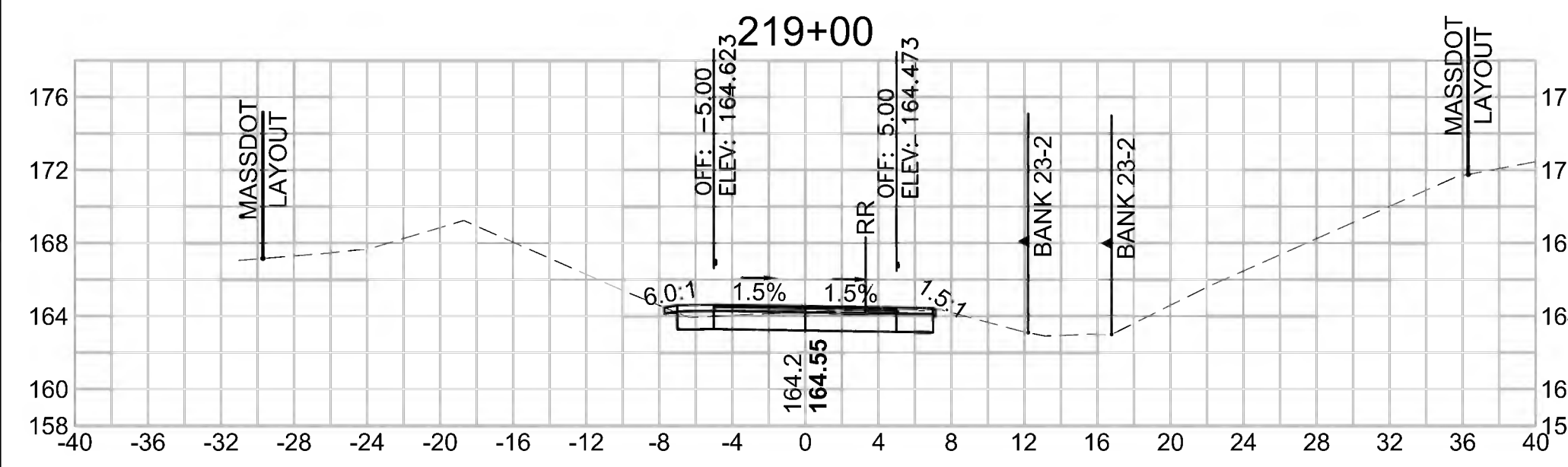

Total Volume at Station 220+50.00	
Cut Area (SF)	20.886
Fill Area (SF)	0.009
Cut Vol (CF)	38.0
Fill Vol (CF)	0.0
Cum Cut Vol (CF)	6566.7
Cum Fill Vol (CF)	4896.2
Net Vol (CF)	1670.5

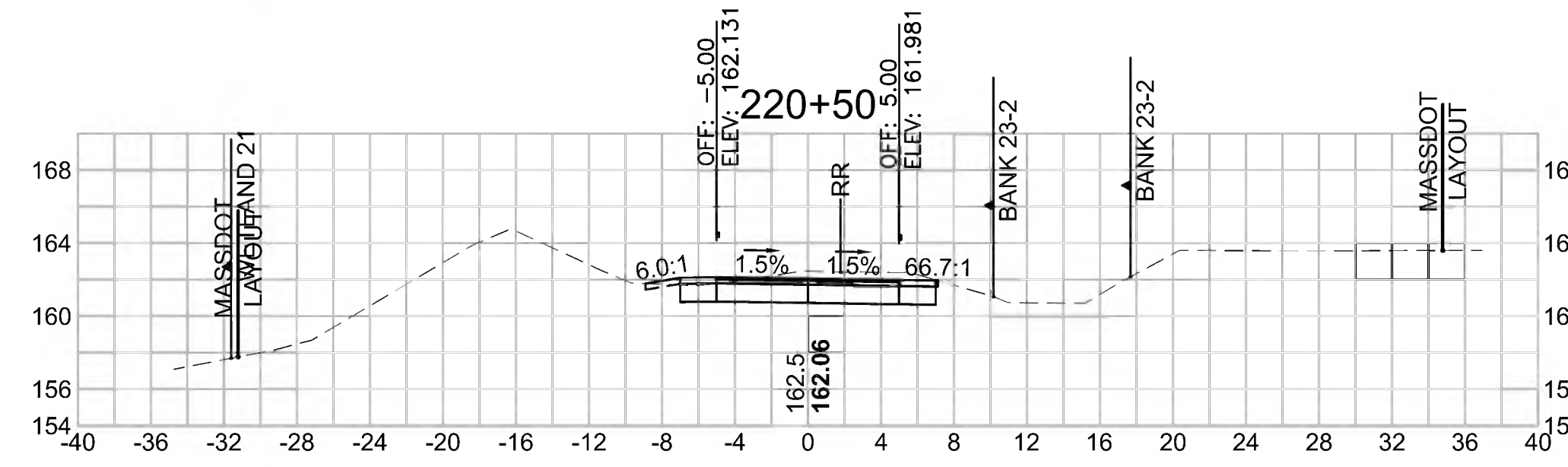

Total Volume at Station 222+00.00	
Cut Area (SF)	36.279
Fill Area (SF)	0.043
Cut Vol (CF)	60.3
Fill Vol (CF)	0.0
Cum Cut Vol (CF)	6720.3
Cum Fill Vol (CF)	4896.2
Net Vol (CF)	1824.1

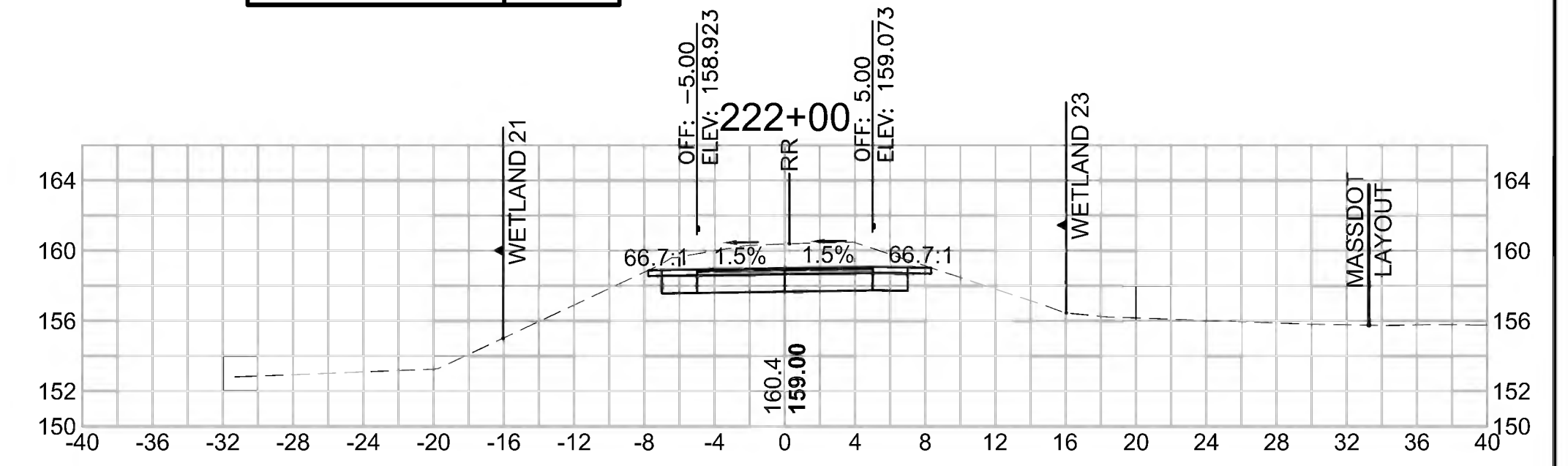

Total Volume at Station 218+50.00	
Cut Area (SF)	10.300
Fill Area (SF)	0.030
Cut Vol (CF)	17.8
Fill Vol (CF)	0.1
Cum Cut Vol (CF)	6441.4
Cum Fill Vol (CF)	4896.1
Net Vol (CF)	1545.3

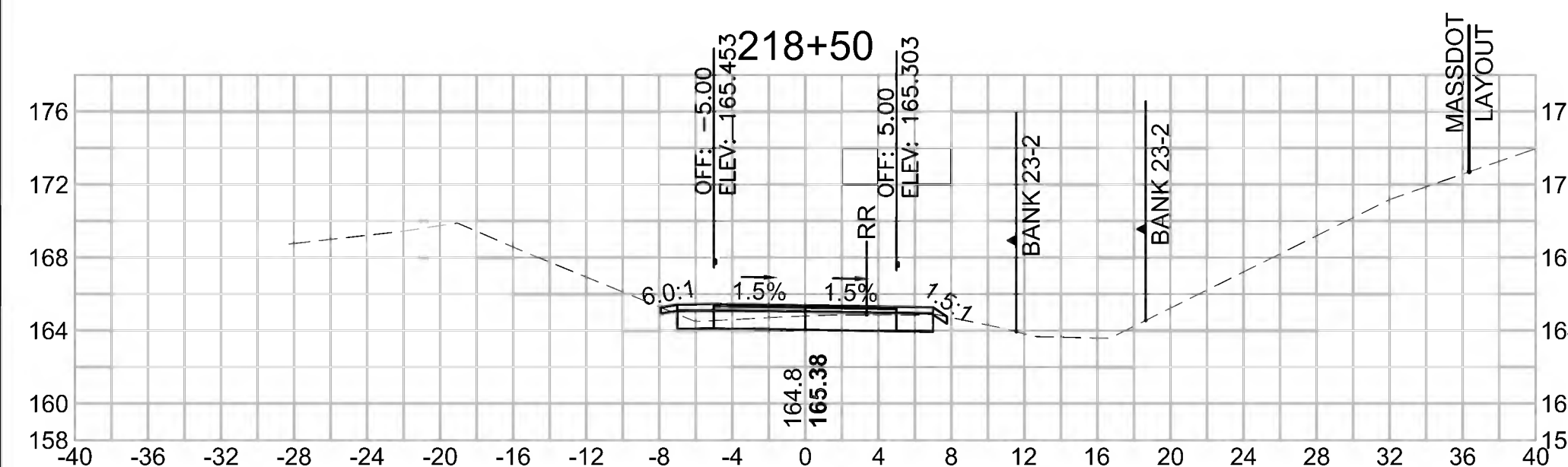

Total Volume at Station 220+00.00	
Cut Area (SF)	20.136
Fill Area (SF)	0.001
Cut Vol (CF)	35.3
Fill Vol (CF)	0.0
Cum Cut Vol (CF)	6528.7
Cum Fill Vol (CF)	4896.2
Net Vol (CF)	1632.5

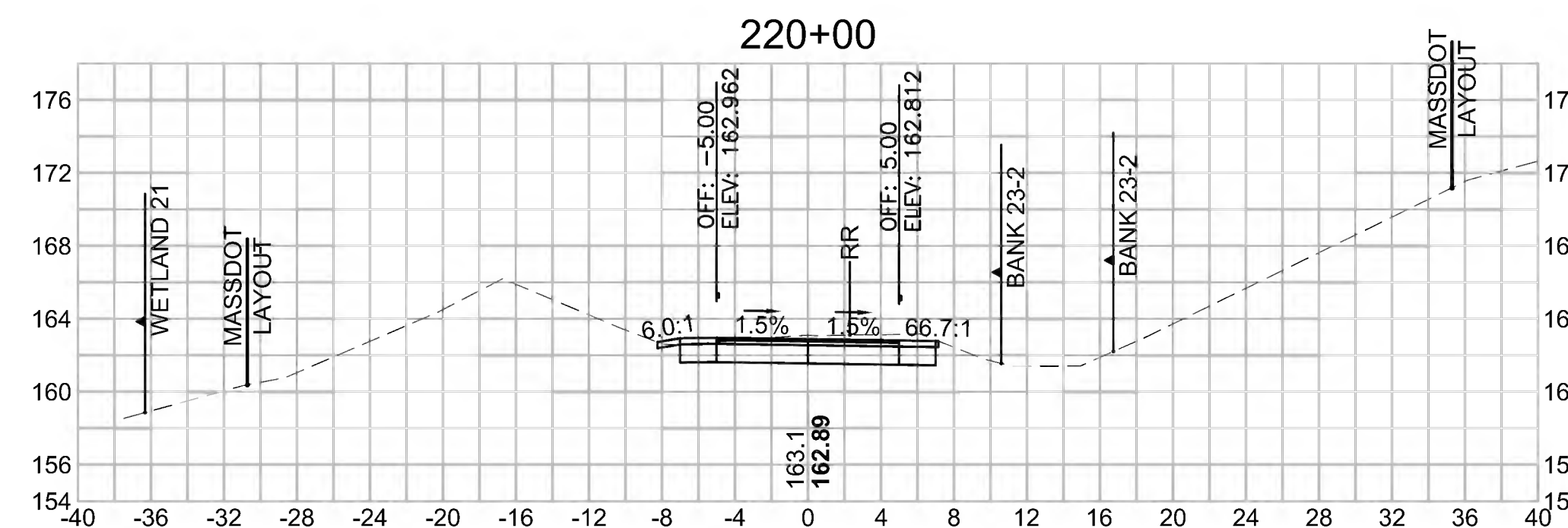

Total Volume at Station 221+50.00	
Cut Area (SF)	28.856
Fill Area (SF)	0.000
Cut Vol (CF)	50.3
Fill Vol (CF)	0.0
Cum Cut Vol (CF)	6660.0
Cum Fill Vol (CF)	4896.2
Net Vol (CF)	1763.8

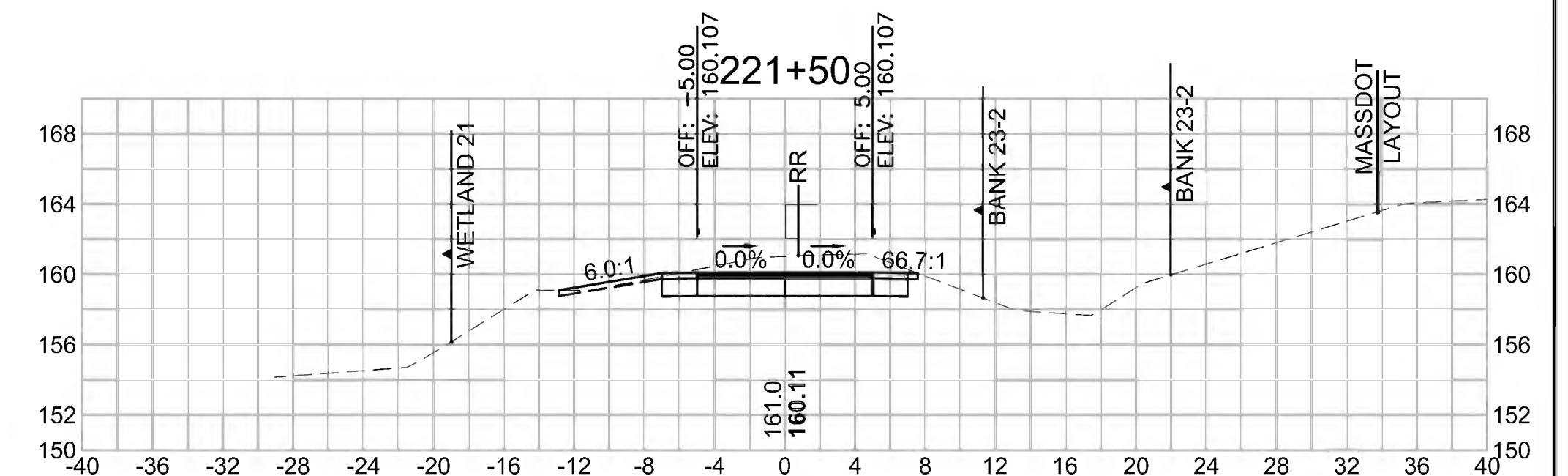

Total Volume at Station 218+00.00	
Cut Area (SF)	8.908
Fill Area (SF)	0.096
Cut Vol (CF)	13.0
Fill Vol (CF)	0.3
Cum Cut Vol (CF)	6423.6
Cum Fill Vol (CF)	4896.0
Net Vol (CF)	1527.6

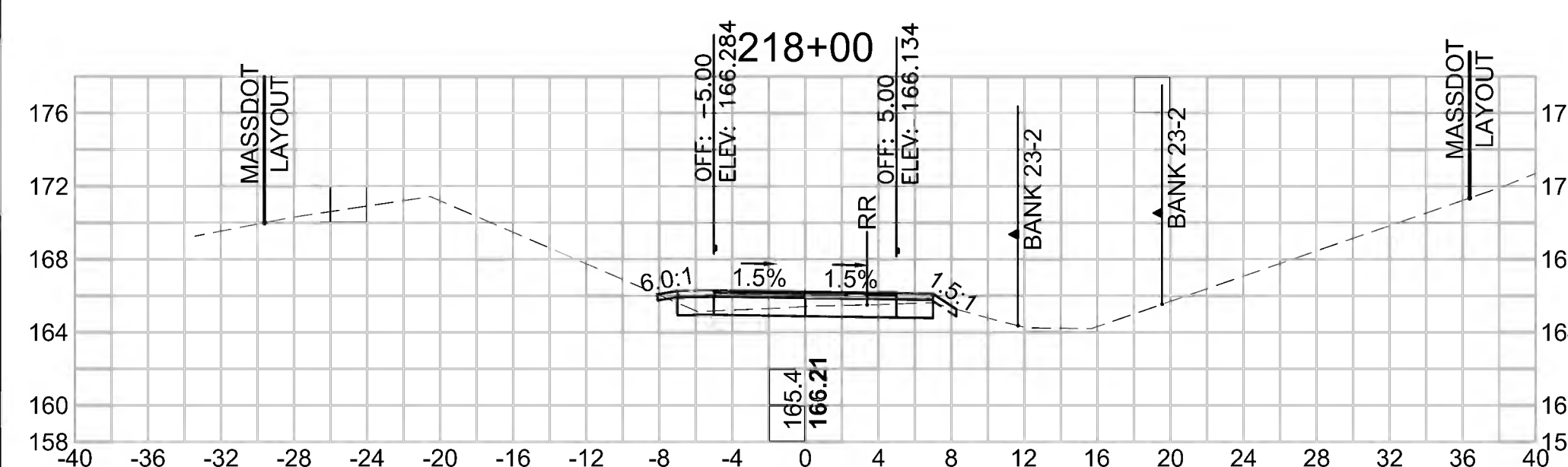

Total Volume at Station 219+50.00	
Cut Area (SF)	17.969
Fill Area (SF)	0.000
Cut Vol (CF)	29.6
Fill Vol (CF)	0.0
Cum Cut Vol (CF)	6493.4
Cum Fill Vol (CF)	4896.2
Net Vol (CF)	1597.2

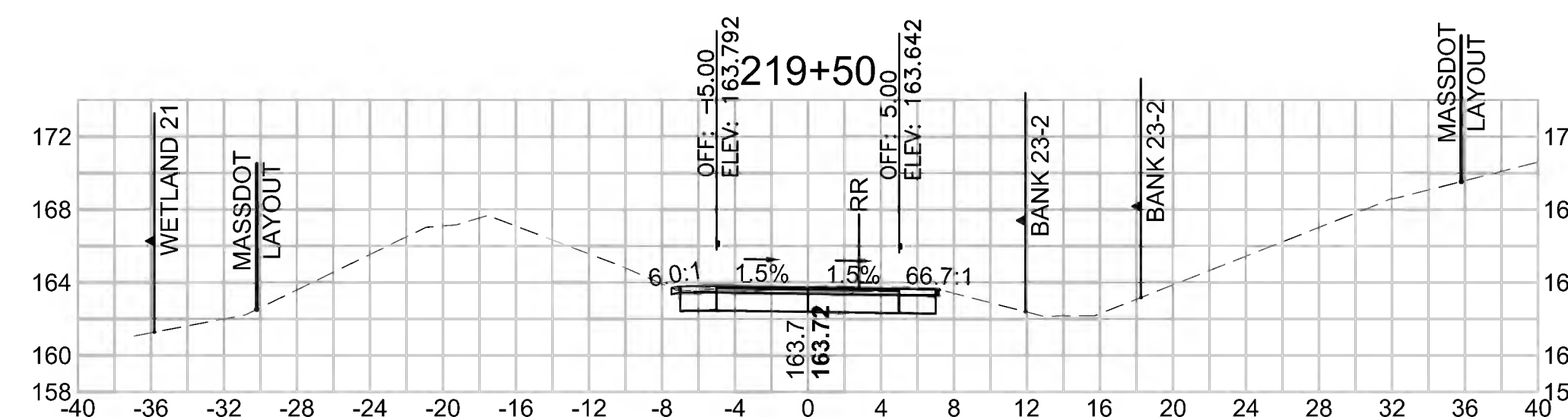

Total Volume at Station 221+00.00	
Cut Area (SF)	25.513
Fill Area (SF)	0.000
Cut Vol (CF)	43.0
Fill Vol (CF)	0.0
Cum Cut Vol (CF)	6609.6
Cum Fill Vol (CF)	4896.2
Net Vol (CF)	1713.5

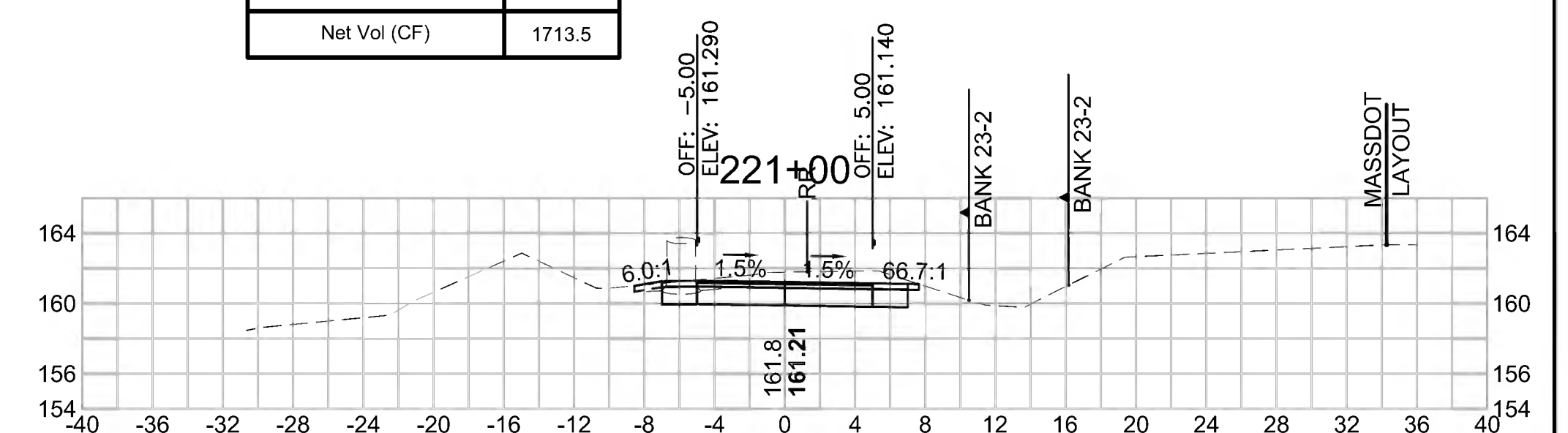

SUDBURY
BRUCE FREEMAN RAIL TRAIL

STATE	FED. AID PROJ. NO.	SHEET NO.	TOTAL SHEETS
MA	XXX-XXXX(XXX)X	274	319

CROSS SECTIONS

Total Volume at Station 223+50.00

Cut Area (SF)	43.892
Fill Area (SF)	0.000
Cut Vol (CF)	76.7
Fill Vol (CF)	0.0
Cum Cut Vol (CF)	6935.3
Cum Fill Vol (CF)	4896.7
Net Vol (CF)	2038.5

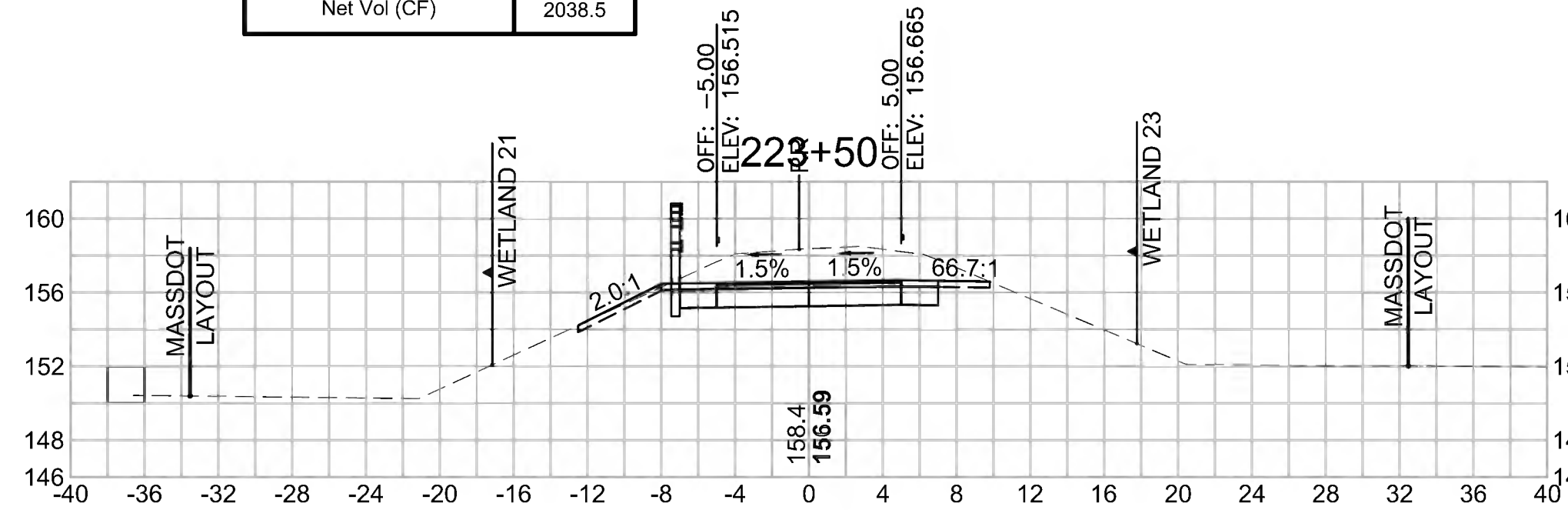

Total Volume at Station 225+00.00

Cut Area (SF)	37.322
Fill Area (SF)	0.005
Cut Vol (CF)	69.9
Fill Vol (CF)	0.0
Cum Cut Vol (CF)	7150.5
Cum Fill Vol (CF)	4896.7
Net Vol (CF)	2253.8

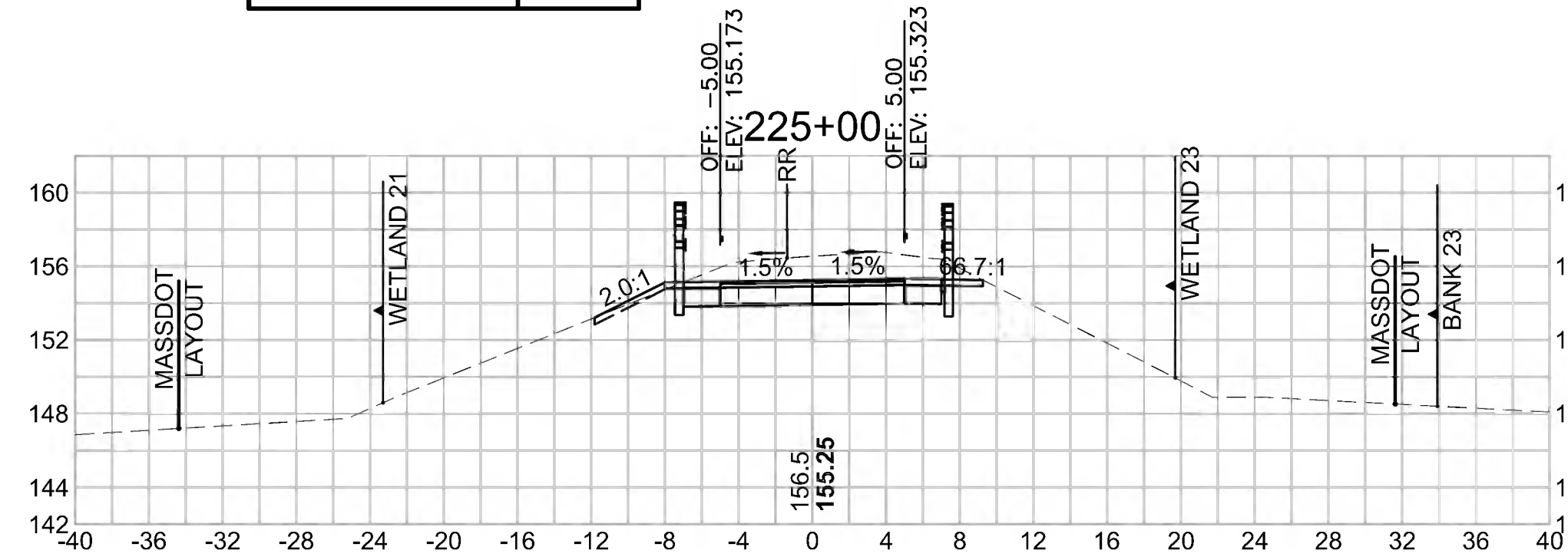

Total Volume at Station 226+50.00

Cut Area (SF)	37.298
Fill Area (SF)	0.000
Cut Vol (CF)	68.5
Fill Vol (CF)	0.0
Cum Cut Vol (CF)	7359.2
Cum Fill Vol (CF)	4896.7
Net Vol (CF)	2462.5

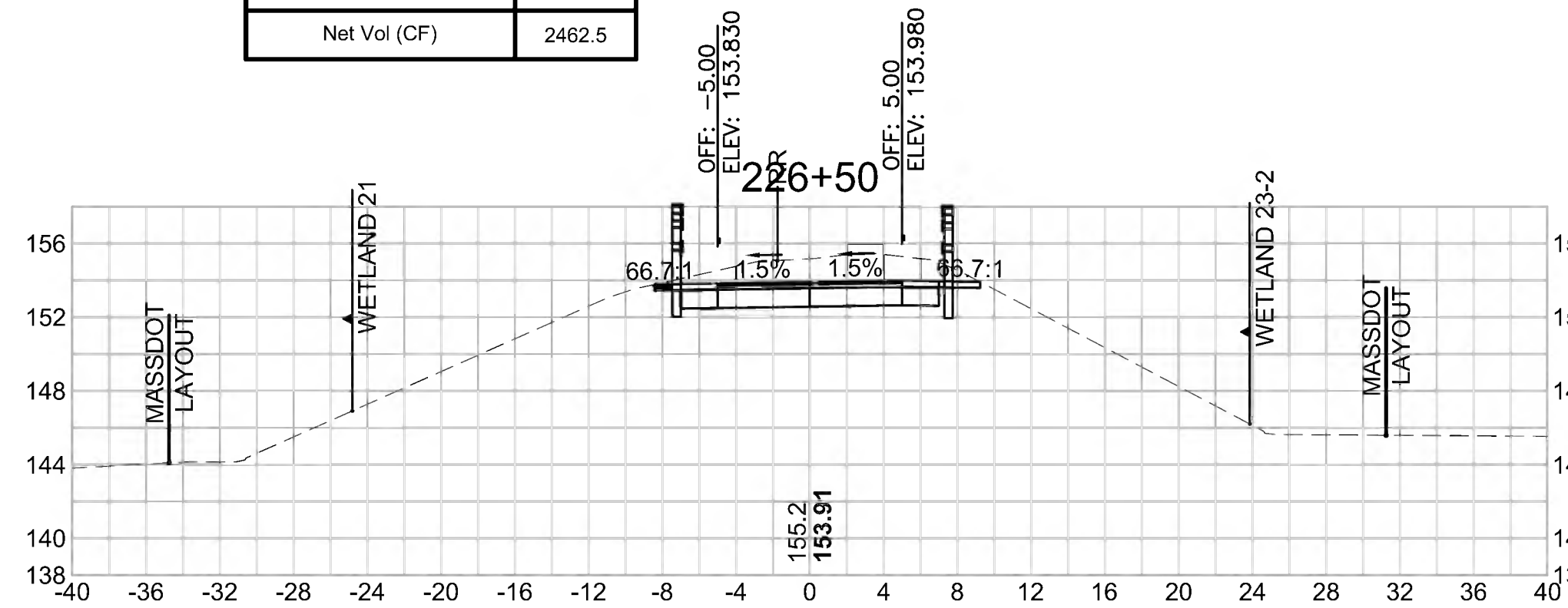

Total Volume at Station 223+00.00

Cut Area (SF)	38.930
Fill Area (SF)	0.000
Cut Vol (CF)	70.4
Fill Vol (CF)	0.2
Cum Cut Vol (CF)	6858.6
Cum Fill Vol (CF)	4896.7
Net Vol (CF)	1961.9

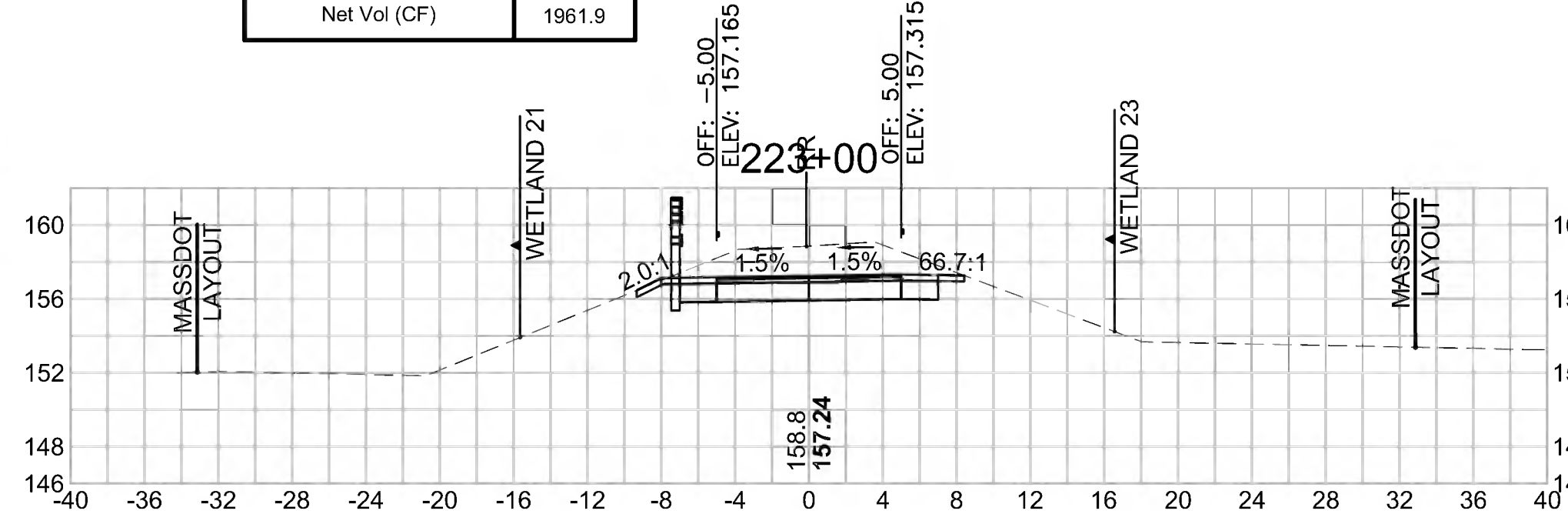

Total Volume at Station 224+50.00

Cut Area (SF)	38.133
Fill Area (SF)	0.000
Cut Vol (CF)	70.0
Fill Vol (CF)	0.0
Cum Cut Vol (CF)	7080.7
Cum Fill Vol (CF)	4896.7
Net Vol (CF)	2183.9

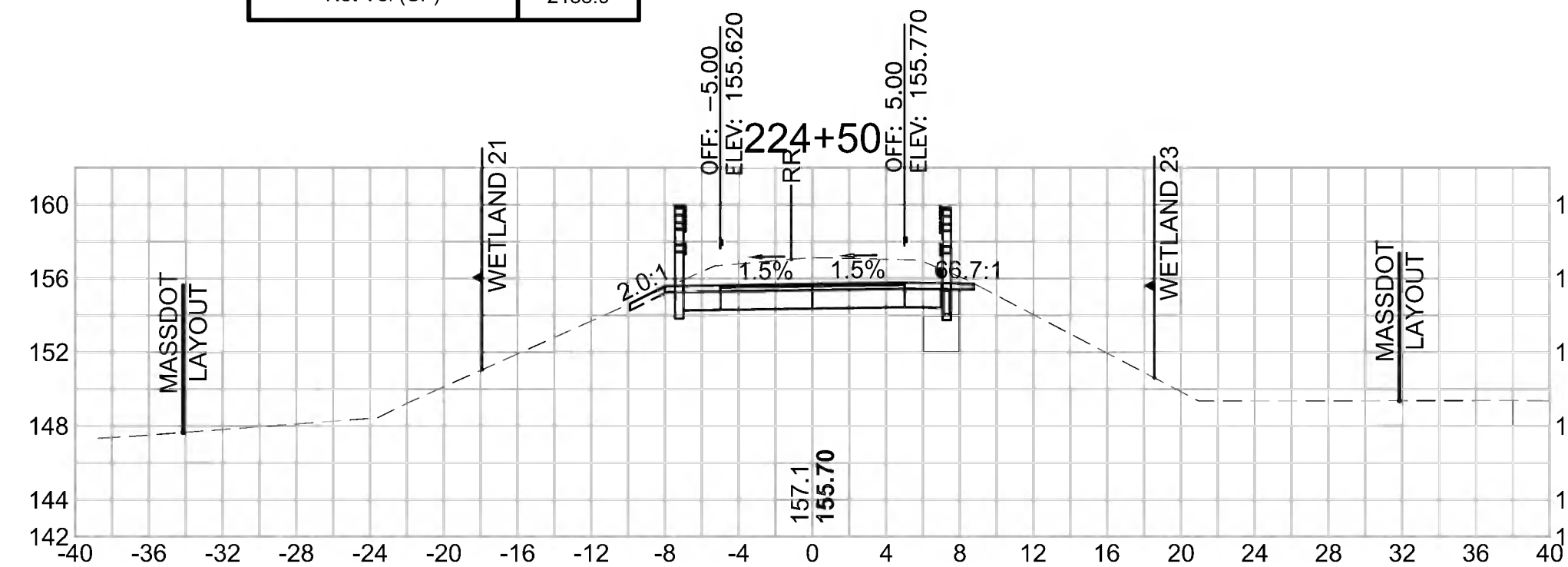

Total Volume at Station 226+00.00

Cut Area (SF)	36.682
Fill Area (SF)	0.000
Cut Vol (CF)	69.8
Fill Vol (CF)	0.0
Cum Cut Vol (CF)	7290.7
Cum Fill Vol (CF)	4896.7
Net Vol (CF)	2394.0

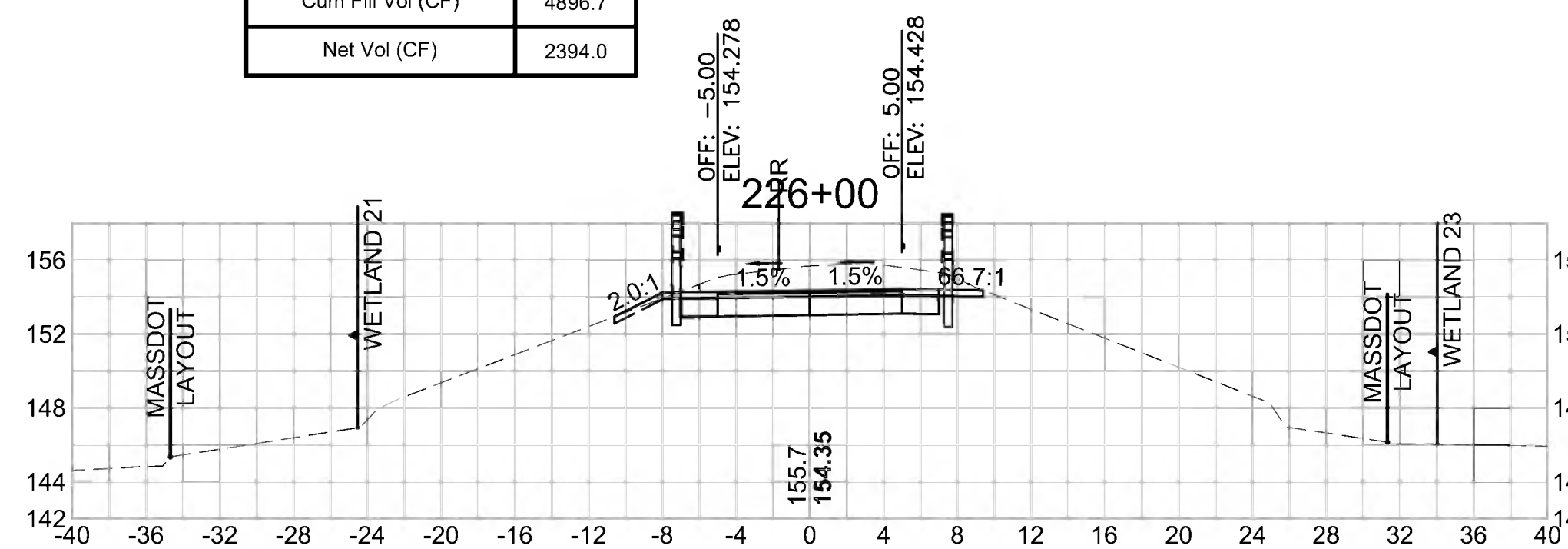

Total Volume at Station 222+50.00

Cut Area (SF)	37.086
Fill Area (SF)	0.261
Cut Vol (CF)	67.9
Fill Vol (CF)	0.3
Cum Cut Vol (CF)	6788.2
Cum Fill Vol (CF)	4896.5
Net Vol (CF)	1891.7

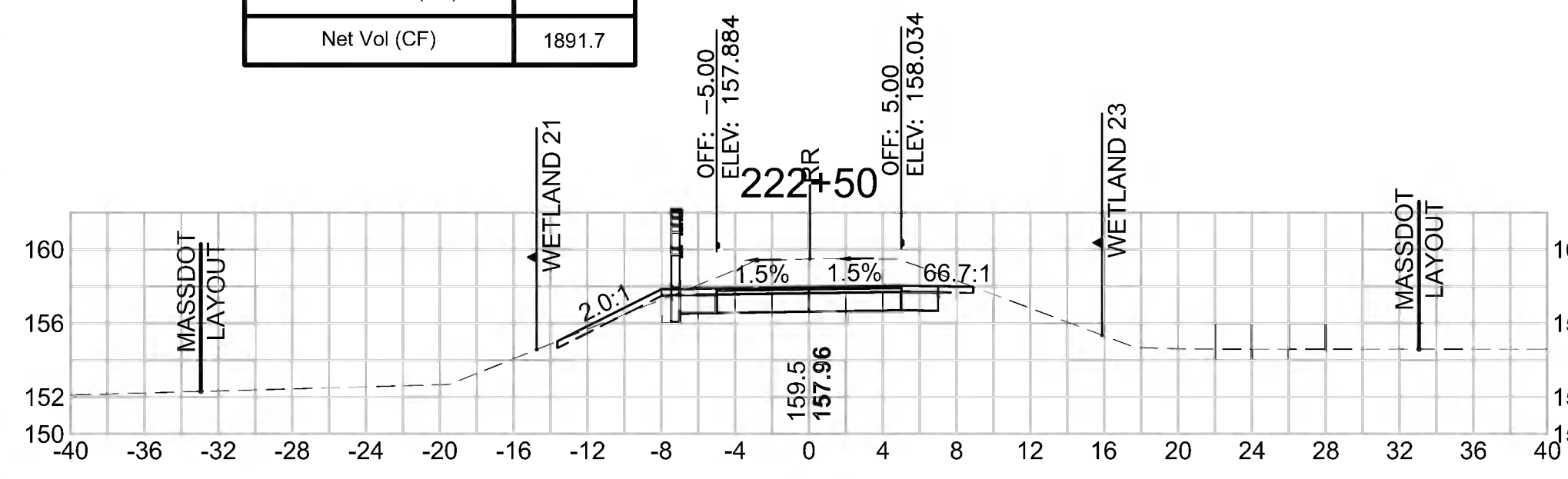

Total Volume at Station 224+00.00

Cut Area (SF)	37.492
Fill Area (SF)	0.000
Cut Vol (CF)	75.4
Fill Vol (CF)	0.0
Cum Cut Vol (CF)	7010.6
Cum Fill Vol (CF)	4896.7
Net Vol (CF)	2113.9

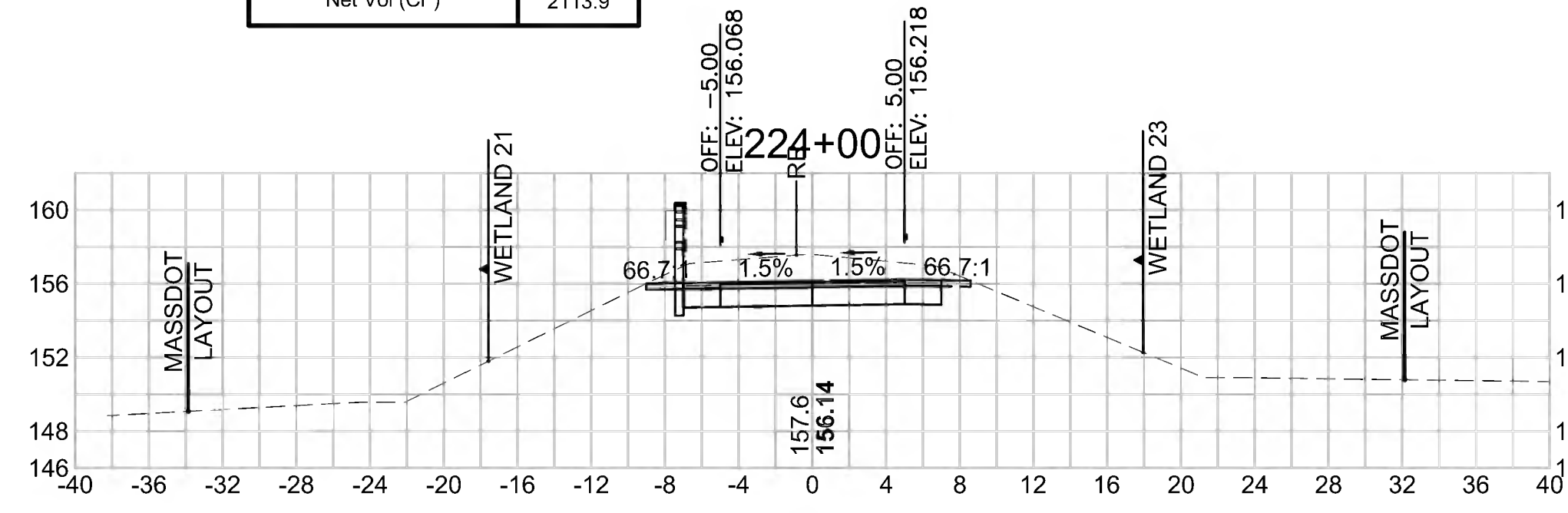

Total Volume at Station 225+50.00

Cut Area (SF)	38.695
Fill Area (SF)	0.000
Cut Vol (CF)	70.4
Fill Vol (CF)	0.0
Cum Cut Vol (CF)	7220.9
Cum Fill Vol (CF)	4896.7
Net Vol (CF)	2324.2

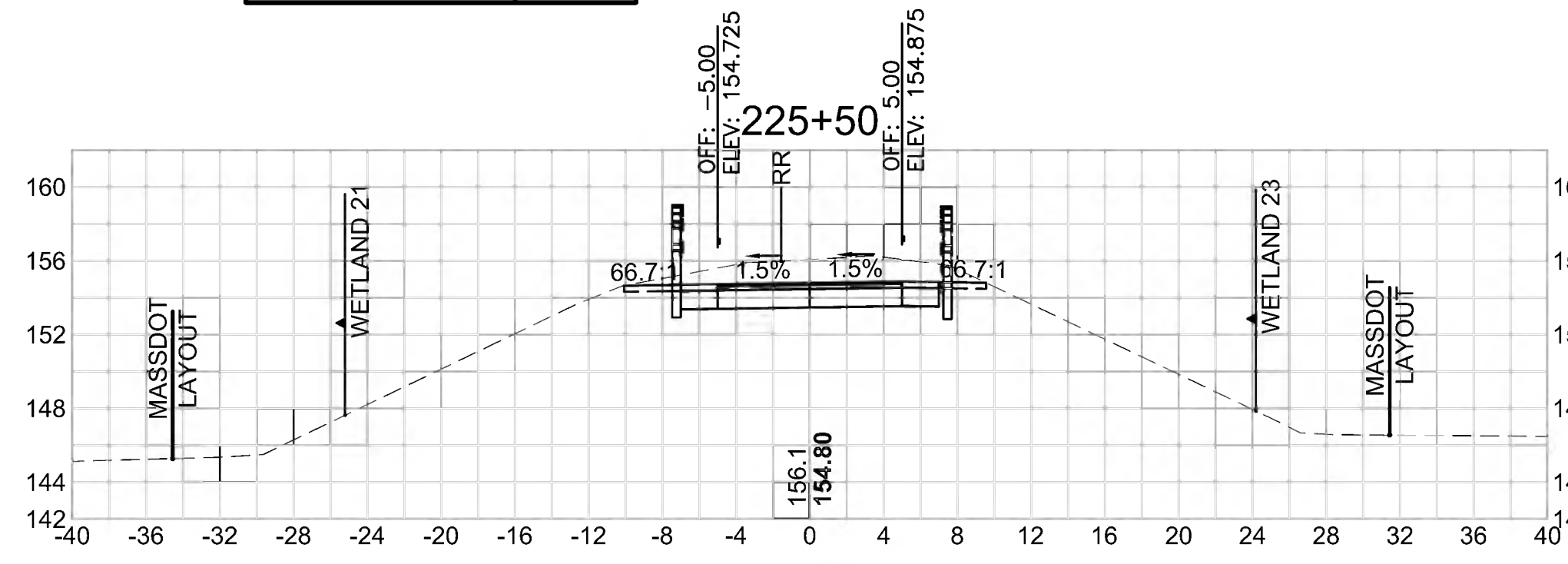

SUDBURY
BRUCE FREEMAN RAIL TRAIL

STATE	FED. AID PROJ. NO.	SHEET NO.	TOTAL SHEETS
MA	XXX-XXXX(XXX)X	275	319
PROJECT FILE NO. 608164			

CROSS SECTIONS

Total Volume at Station 228+00.00	
Cut Area (SF)	34.618
Fill Area (SF)	0.000
Cut Vol (CF)	66.5
Fill Vol (CF)	0.0
Cum Cut Vol (CF)	7567.6
Cum Fill Vol (CF)	4896.7
Net Vol (CF)	2670.8

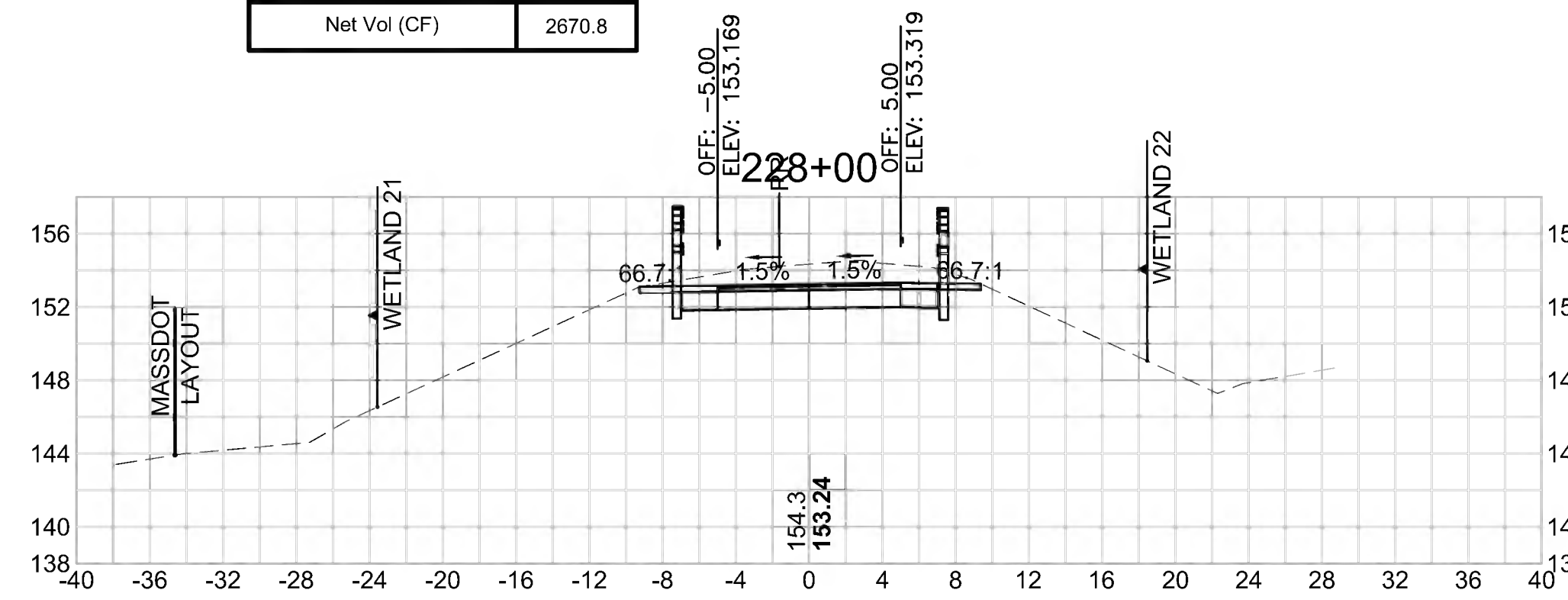

Total Volume at Station 229+50.00	
Cut Area (SF)	34.762
Fill Area (SF)	0.000
Cut Vol (CF)	58.5
Fill Vol (CF)	0.0
Cum Cut Vol (CF)	7740.0
Cum Fill Vol (CF)	4896.7
Net Vol (CF)	2843.2

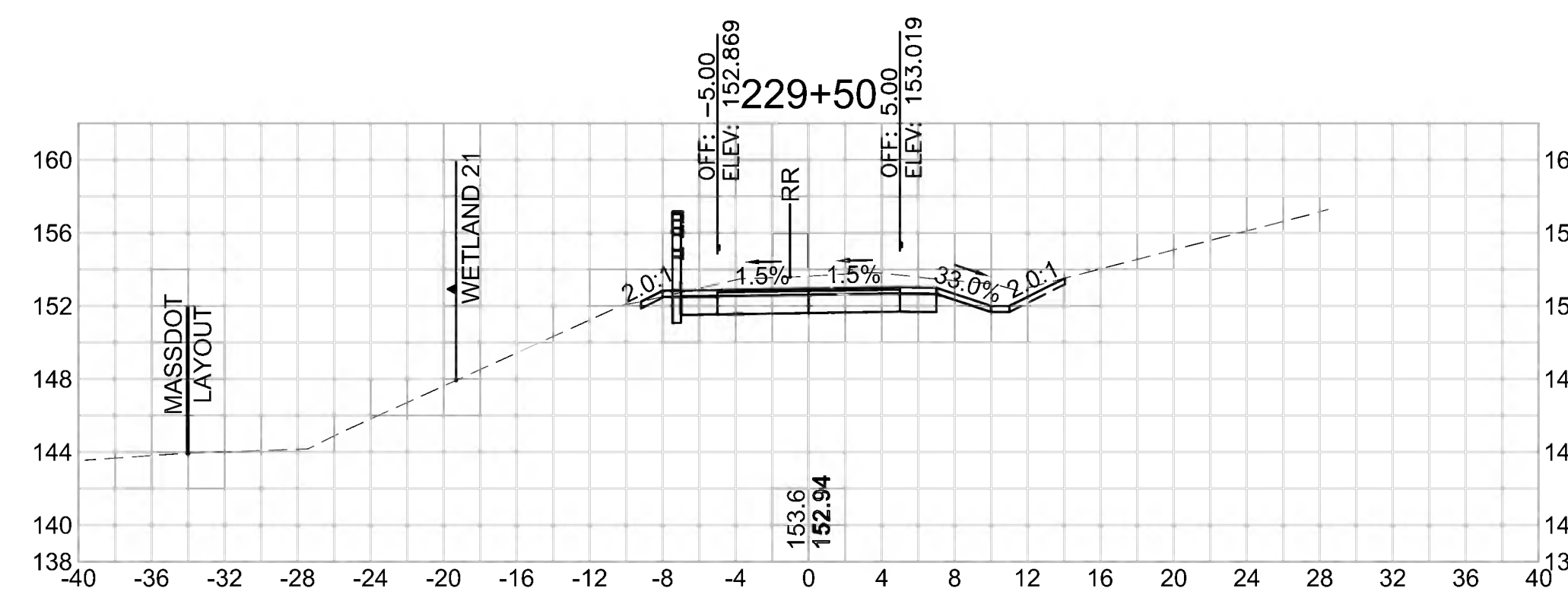

Total Volume at Station 227+50.00	
Cut Area (SF)	37.191
Fill Area (SF)	0.000
Cut Vol (CF)	70.9
Fill Vol (CF)	0.0
Cum Cut Vol (CF)	7501.1
Cum Fill Vol (CF)	4896.7
Net Vol (CF)	2604.3

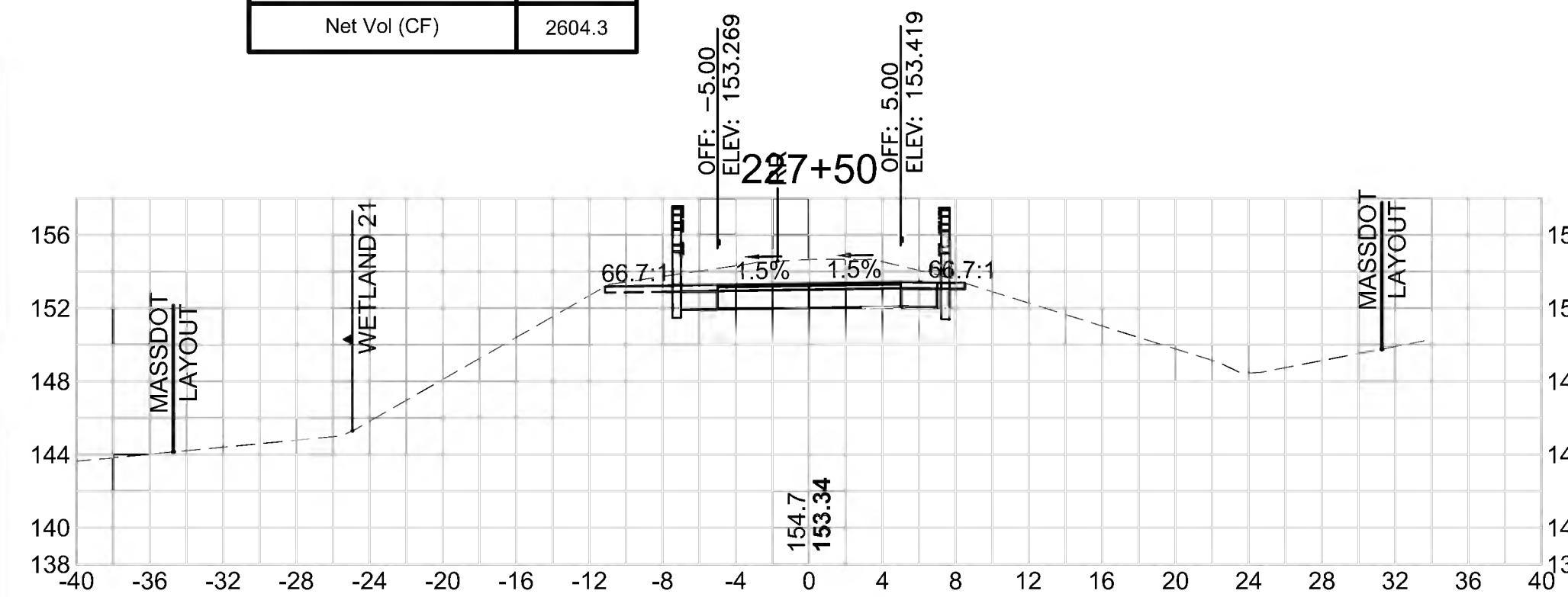

Total Volume at Station 229+00.00	
Cut Area (SF)	28.437
Fill Area (SF)	0.000
Cut Vol (CF)	54.1
Fill Vol (CF)	0.0
Cum Cut Vol (CF)	7681.5
Cum Fill Vol (CF)	4896.7
Net Vol (CF)	2784.7

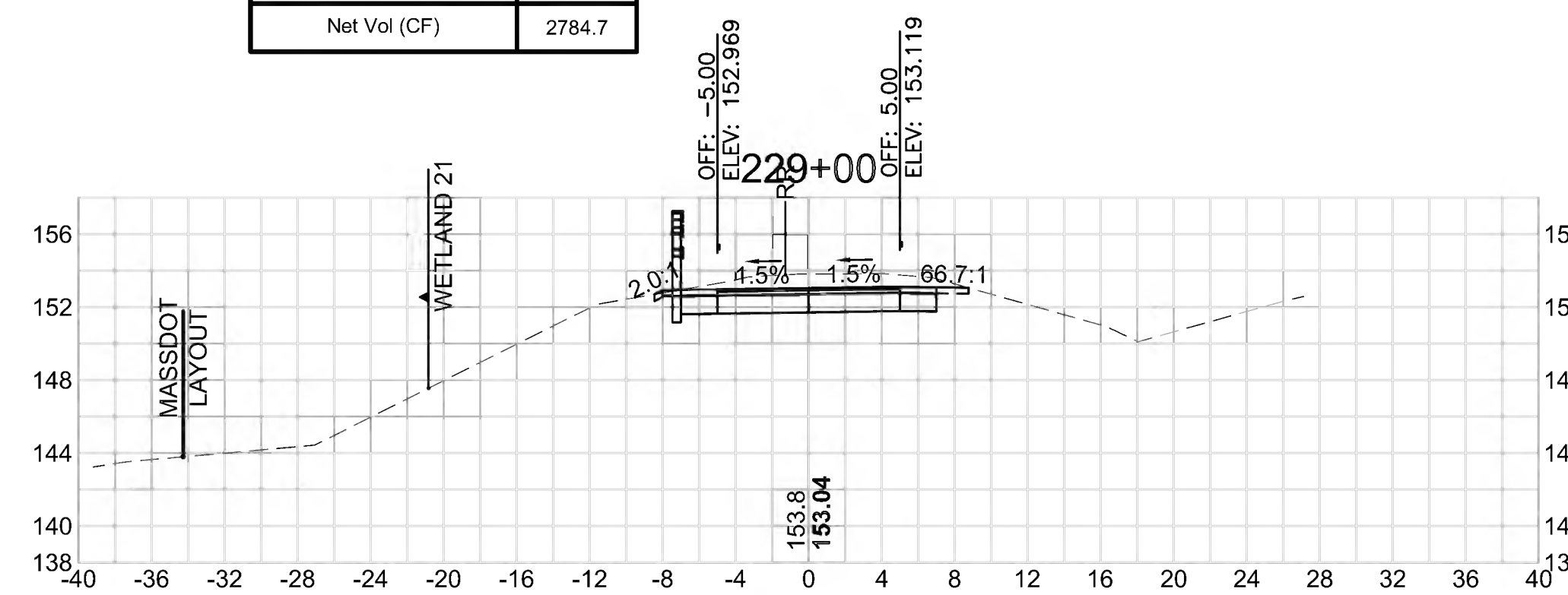

Total Volume at Station 227+00.00	
Cut Area (SF)	39.361
Fill Area (SF)	0.000
Cut Vol (CF)	71.0
Fill Vol (CF)	0.0
Cum Cut Vol (CF)	7430.2
Cum Fill Vol (CF)	4896.7
Net Vol (CF)	2533.4

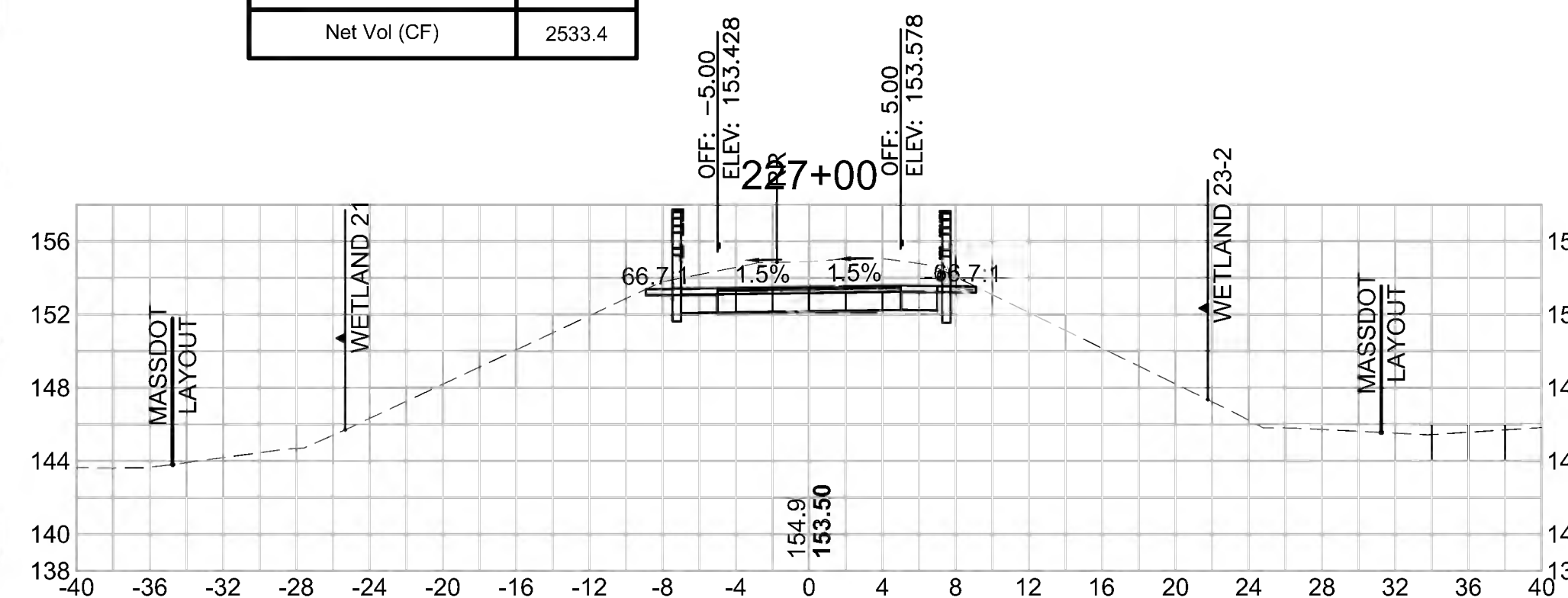

Total Volume at Station 228+50.00	
Cut Area (SF)	29.980
Fill Area (SF)	0.000
Cut Vol (CF)	59.8
Fill Vol (CF)	0.0
Cum Cut Vol (CF)	7627.4
Cum Fill Vol (CF)	4896.7
Net Vol (CF)	2730.6

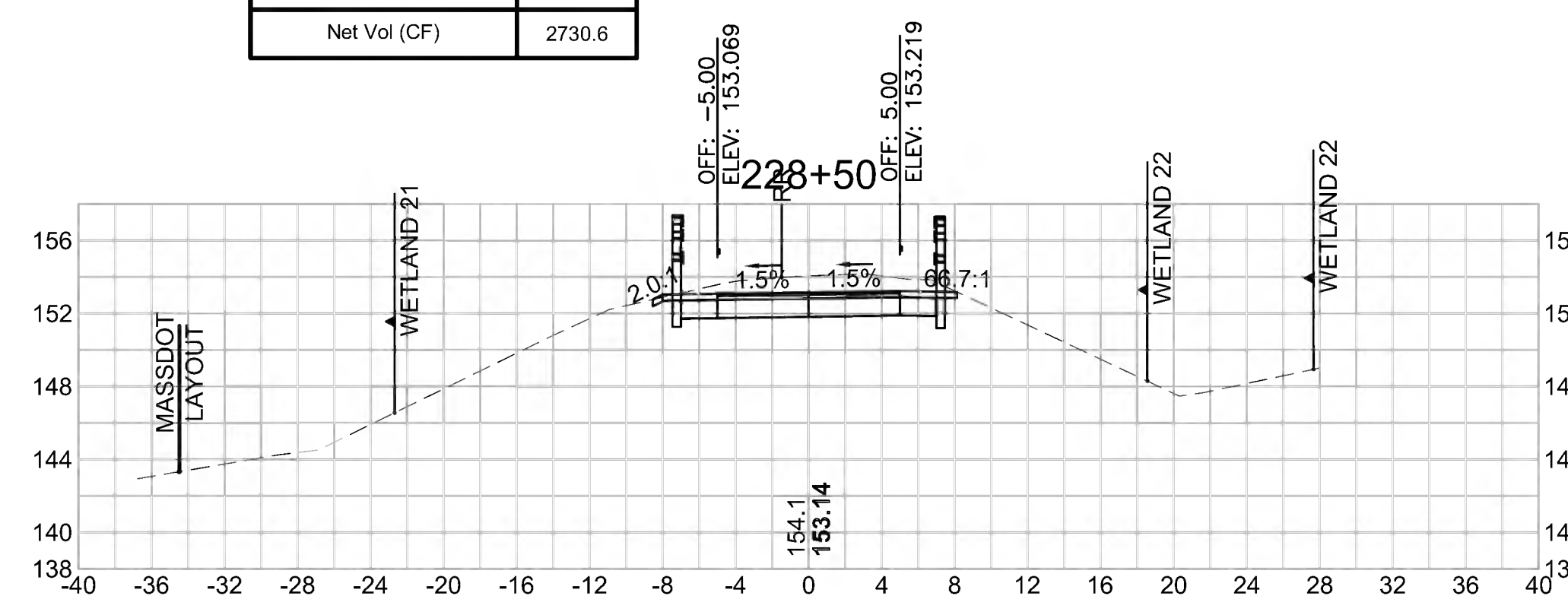

SUDBURY
BRUCE FREEMAN RAIL TRAIL

STATE	FED. AID PROJ. NO.	SHEET NO.	TOTAL SHEETS
MA	XXX-XXXX(XXX)X	276	319
PROJECT FILE NO. 608164			

CROSS SECTIONS

Total Volume at Station 230+50.00

Cut Area (SF)	42.910
Fill Area (SF)	0.000
Cut Vol (CF)	79.0
Fill Vol (CF)	0.2
Cum Cut Vol (CF)	7890.3
Cum Fill Vol (CF)	4897.2
Net Vol (CF)	2993.2

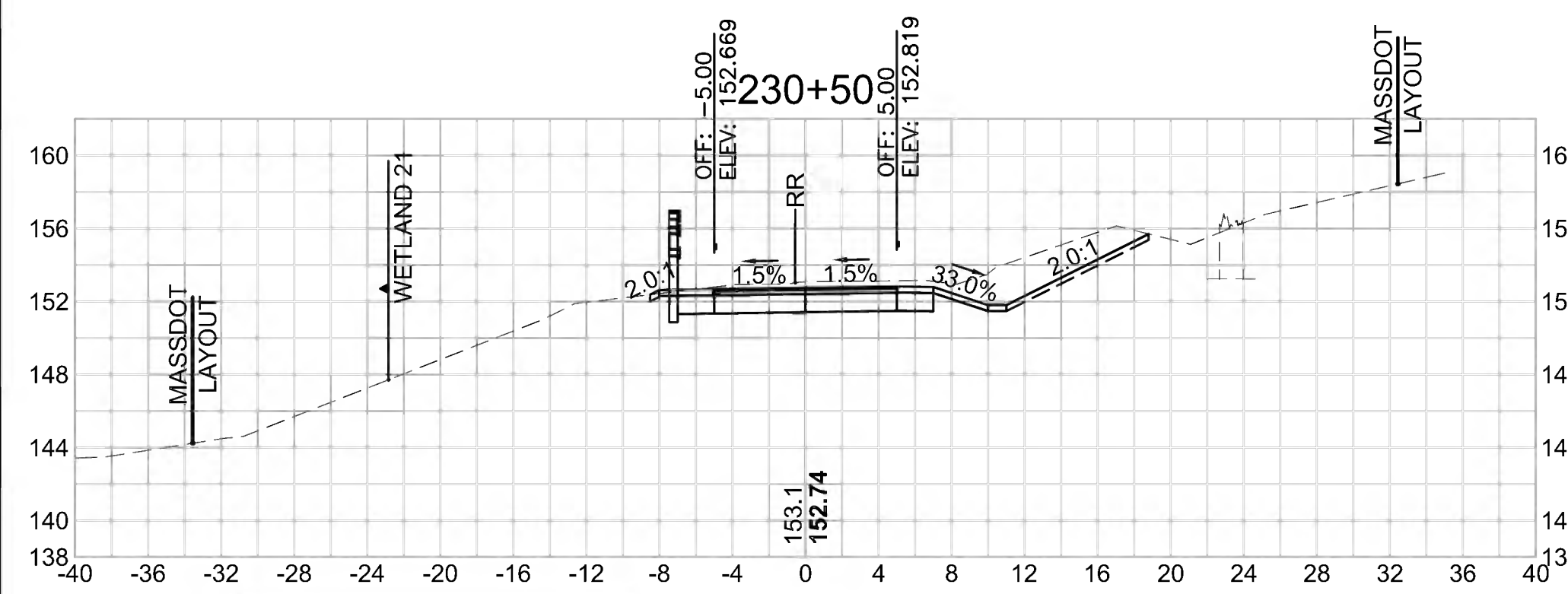

Total Volume at Station 230+00.00

Cut Area (SF)	42.357
Fill Area (SF)	0.240
Cut Vol (CF)	71.4
Fill Vol (CF)	0.2
Cum Cut Vol (CF)	7811.4
Cum Fill Vol (CF)	4897.0
Net Vol (CF)	2914.4

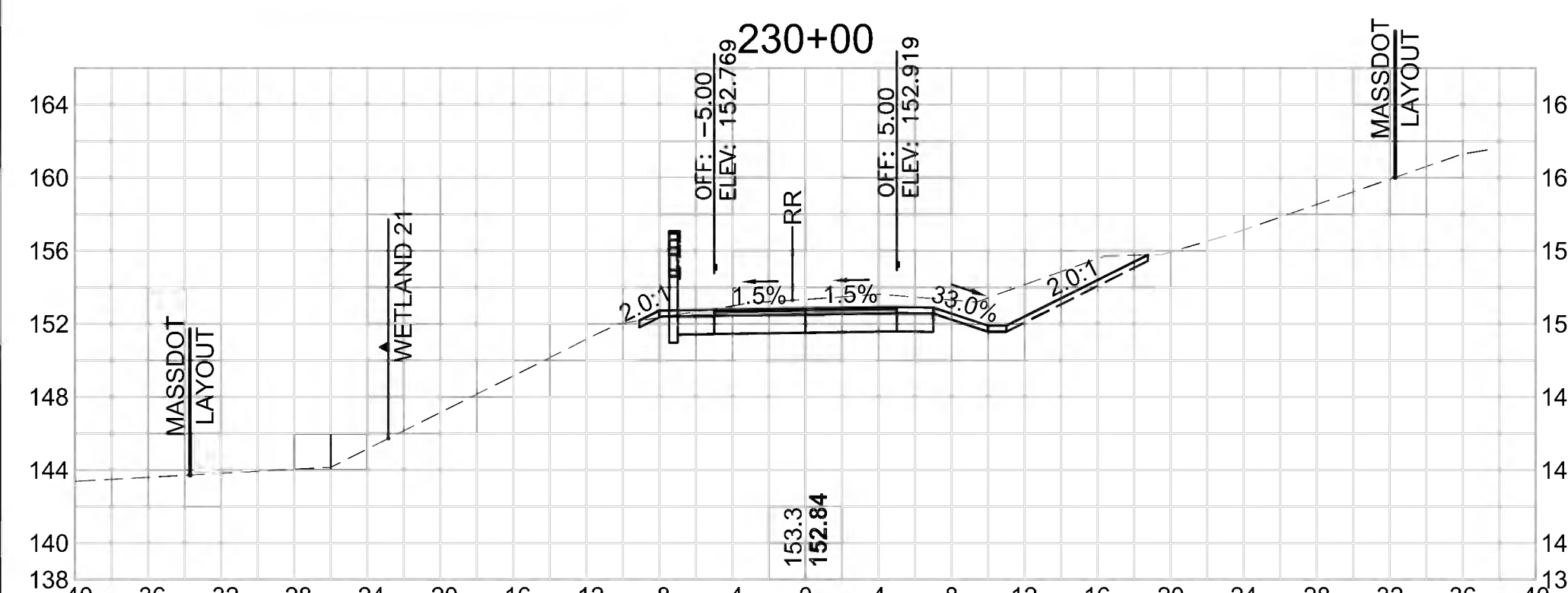

Total Volume at Station 231+50.00

Cut Area (SF)	15.865
Fill Area (SF)	0.944
Cut Vol (CF)	35.9
Fill Vol (CF)	0.9
Cum Cut Vol (CF)	7987.3
Cum Fill Vol (CF)	4898.1
Net Vol (CF)	3089.2

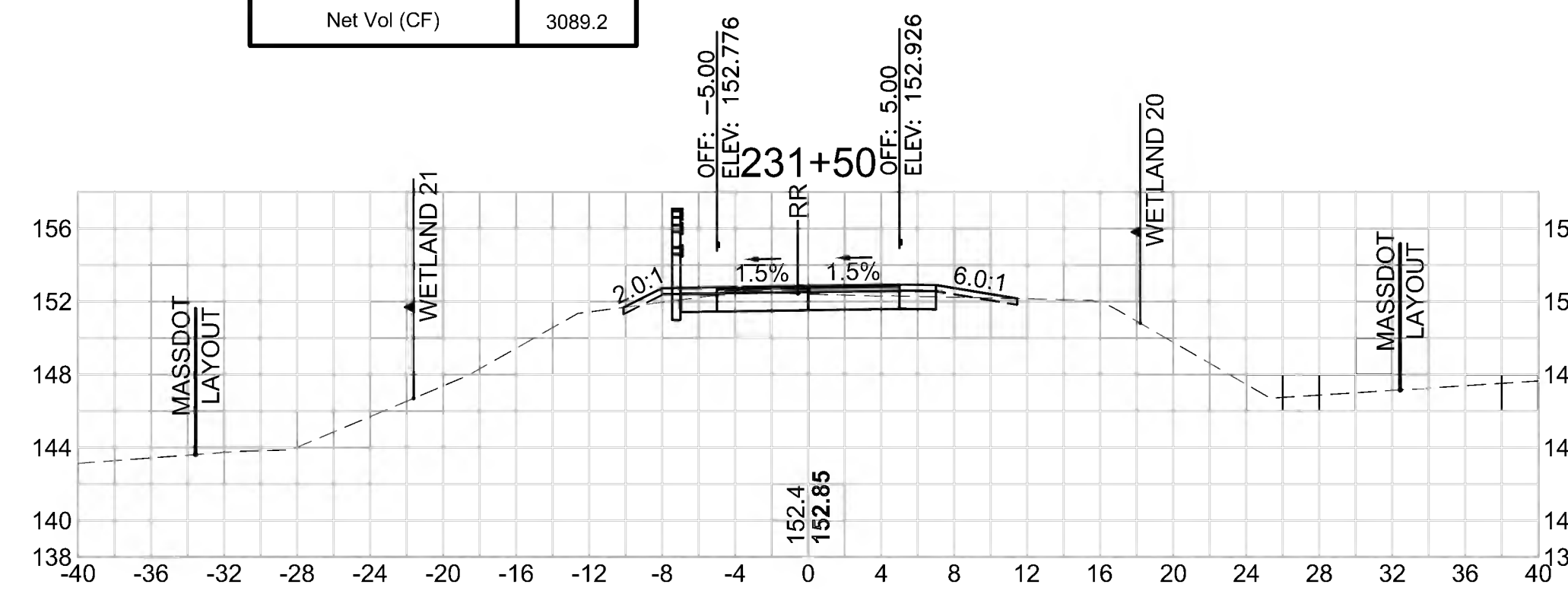

Total Volume at Station 231+00.00

Cut Area (SF)	22.956
Fill Area (SF)	0.022
Cut Vol (CF)	61.0
Fill Vol (CF)	0.0
Cum Cut Vol (CF)	7951.3
Cum Fill Vol (CF)	4897.2
Net Vol (CF)	3054.1

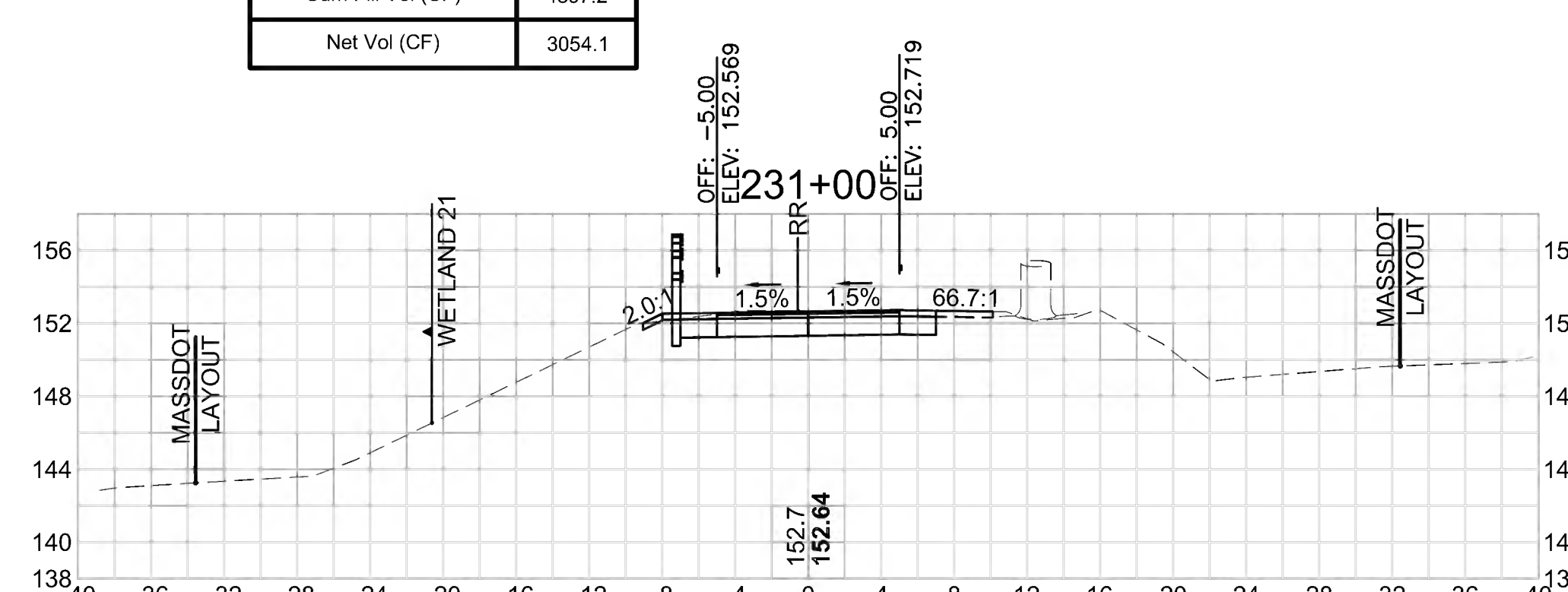

Total Volume at Station 232+50.00

Cut Area (SF)	0.170
Fill Area (SF)	84.794
Cut Vol (CF)	1.8
Fill Vol (CF)	107.0
Cum Cut Vol (CF)	8005.5
Cum Fill Vol (CF)	5034.5
Net Vol (CF)	2971.0

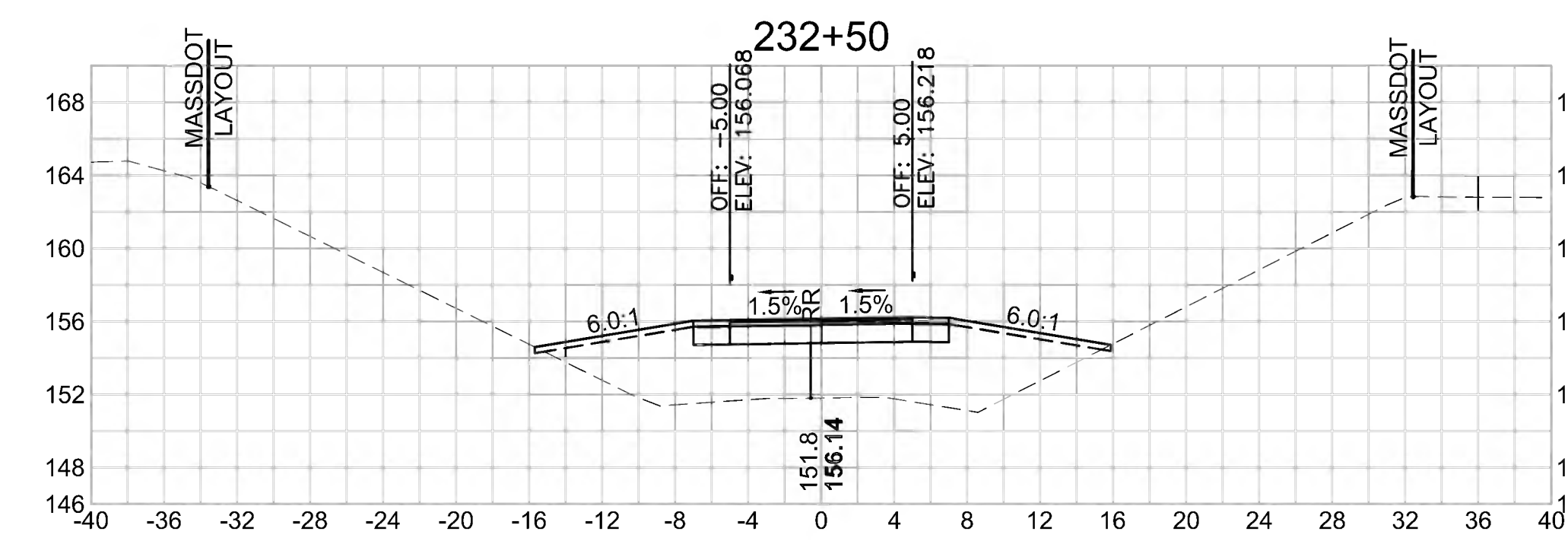

Total Volume at Station 232+00.00

Cut Area (SF)	1.819
Fill Area (SF)	30.775
Cut Vol (CF)	16.4
Fill Vol (CF)	29.4
Cum Cut Vol (CF)	8003.6
Cum Fill Vol (CF)	4927.5
Net Vol (CF)	3076.2

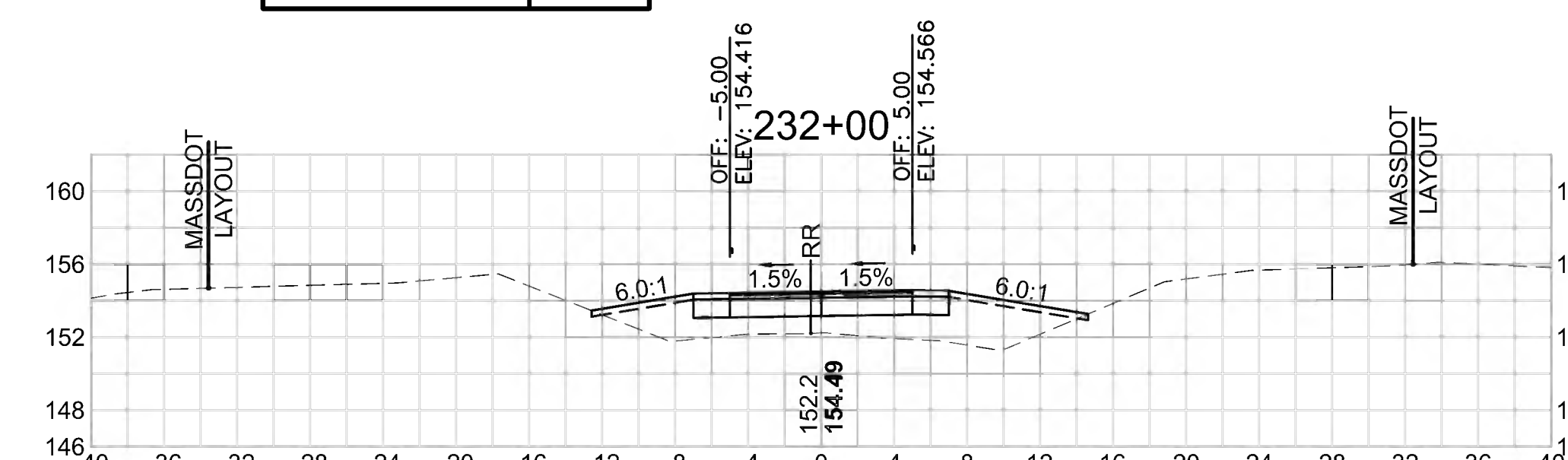

SUDBURY
BRUCE FREEMAN RAIL TRAIL

STATE	FED. AID PROJ. NO.	SHEET NO.	TOTAL SHEETS
MA	XXX-XXX(XXX)X	277	319

PROJECT FILE NO. 608164

CROSS SECTIONS

Total Volume at Station 234+00.00

Cut Area (SF)	0.204
Fill Area (SF)	63.421
Cut Vol (CF)	0.6
Fill Vol (CF)	129.1
Cum Cut Vol (CF)	8011.5
Cum Fill Vol (CF)	5502.7
Net Vol (CF)	2508.8

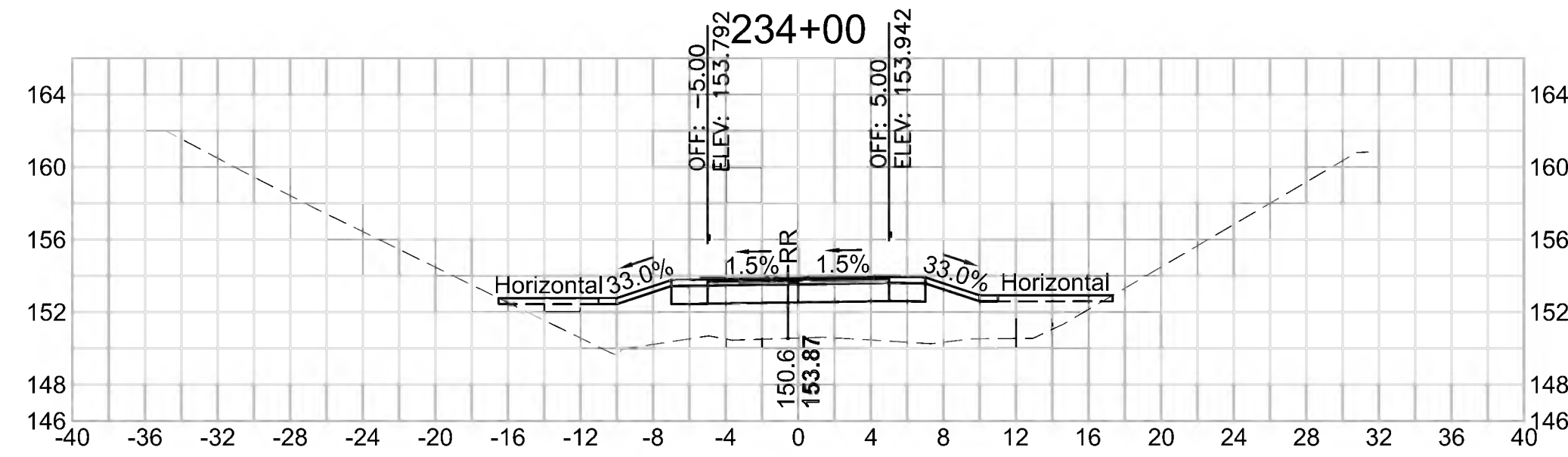

Total Volume at Station 235+50.00

Cut Area (SF)	16.354
Fill Area (SF)	0.584
Cut Vol (CF)	16.3
Fill Vol (CF)	14.4
Cum Cut Vol (CF)	8029.5
Cum Fill Vol (CF)	5680.0
Net Vol (CF)	2349.5

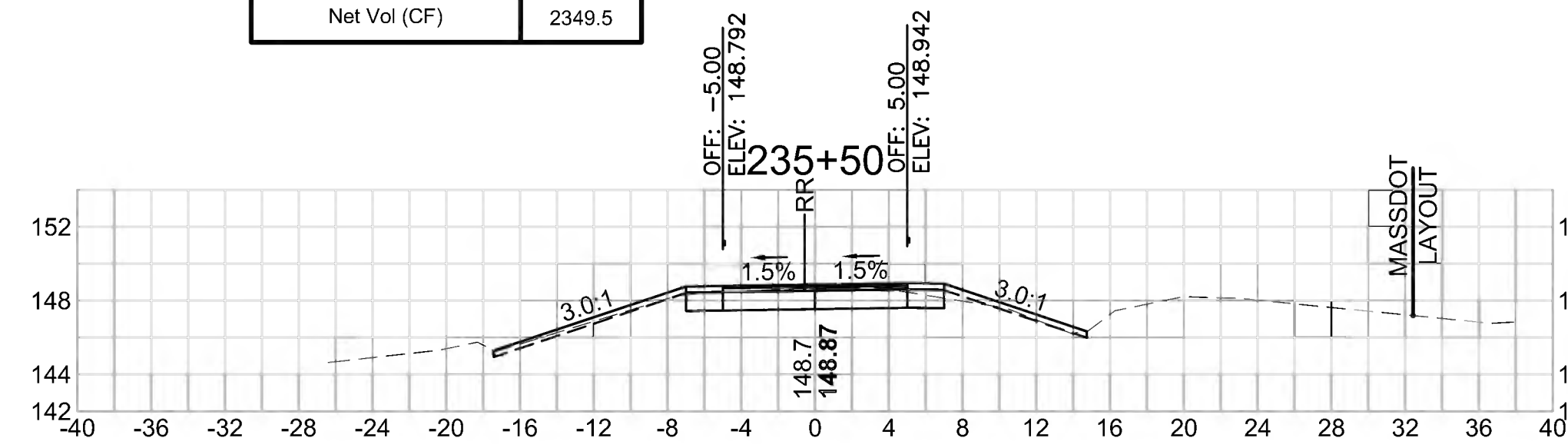

Total Volume at Station 237+00.00

Cut Area (SF)	31.543
Fill Area (SF)	0.012
Cut Vol (CF)	64.5
Fill Vol (CF)	0.0
Cum Cut Vol (CF)	8207.3
Cum Fill Vol (CF)	5680.5
Net Vol (CF)	2526.8

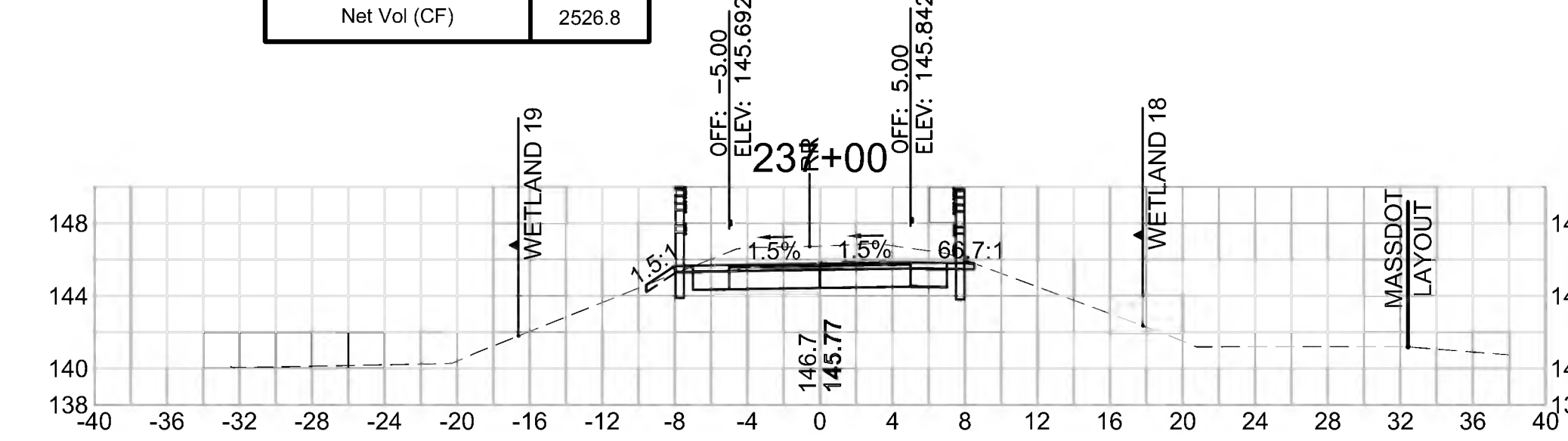

Total Volume at Station 233+50.00

Cut Area (SF)	0.426
Fill Area (SF)	76.015
Cut Vol (CF)	2.9
Fill Vol (CF)	165.5
Cum Cut Vol (CF)	8011.0
Cum Fill Vol (CF)	5373.6
Net Vol (CF)	2637.3

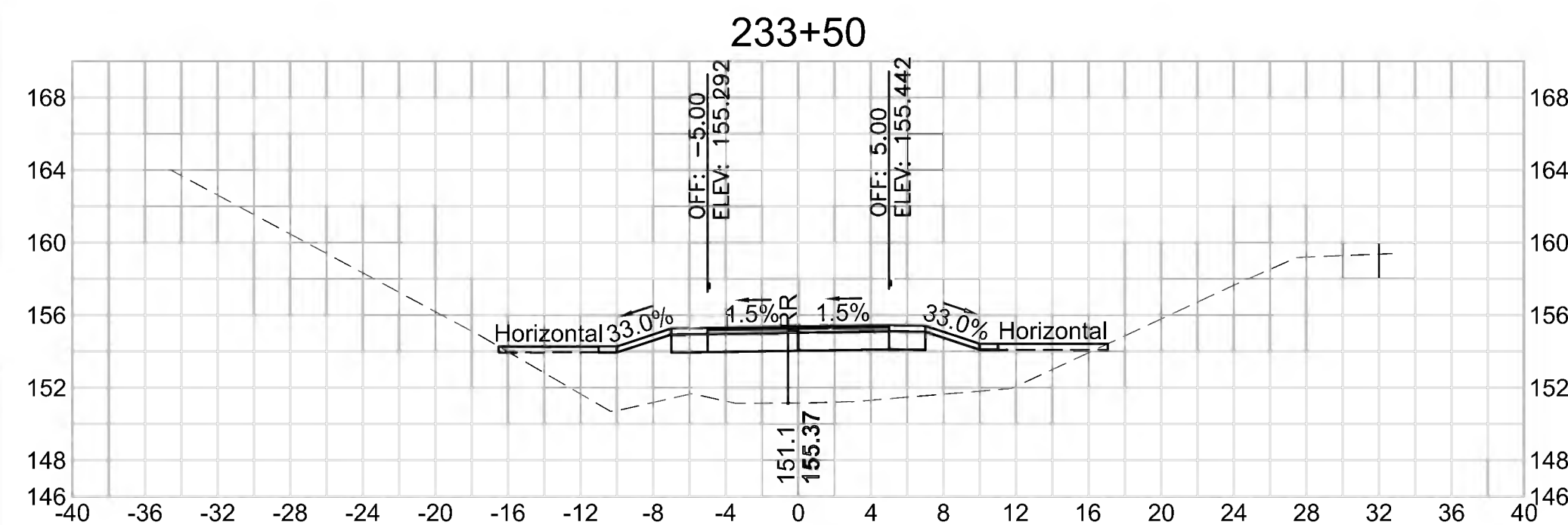

Total Volume at Station 235+00.00

Cut Area (SF)	1.240
Fill Area (SF)	14.979
Cut Vol (CF)	1.3
Fill Vol (CF)	59.0
Cum Cut Vol (CF)	8013.2
Cum Fill Vol (CF)	5665.6
Net Vol (CF)	2347.7

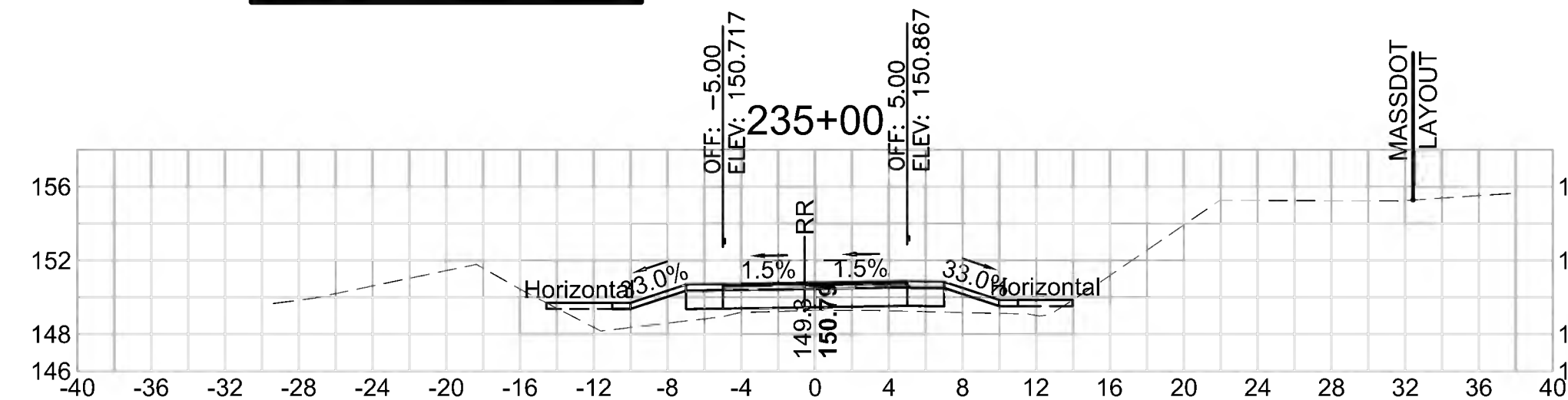

Total Volume at Station 236+50.00

Cut Area (SF)	38.158
Fill Area (SF)	0.000
Cut Vol (CF)	66.7
Fill Vol (CF)	0.0
Cum Cut Vol (CF)	8142.7
Cum Fill Vol (CF)	5680.5
Net Vol (CF)	2462.2

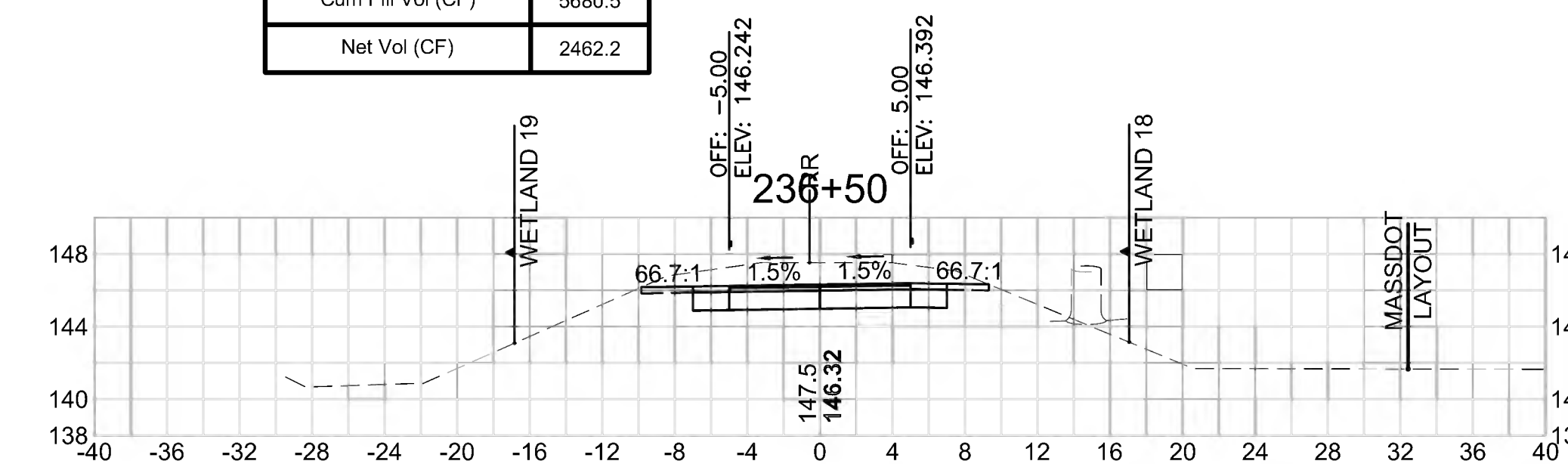

Total Volume at Station 233+00.00

Cut Area (SF)	2.660
Fill Area (SF)	102.746
Cut Vol (CF)	2.6
Fill Vol (CF)	173.6
Cum Cut Vol (CF)	8008.1
Cum Fill Vol (CF)	5208.1
Net Vol (CF)	2800.0

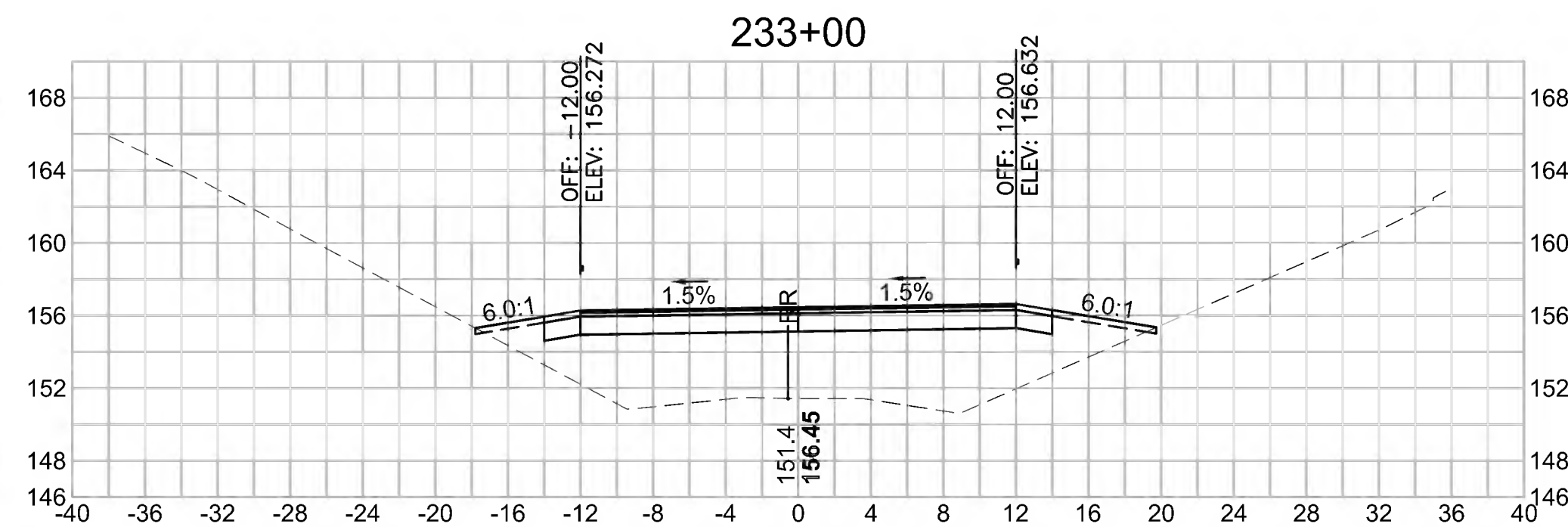

Total Volume at Station 234+50.00

Cut Area (SF)	0.181
Fill Area (SF)	48.716
Cut Vol (CF)	0.4
Fill Vol (CF)	103.8
Cum Cut Vol (CF)	8011.9
Cum Fill Vol (CF)	5606.6
Net Vol (CF)	2405.3

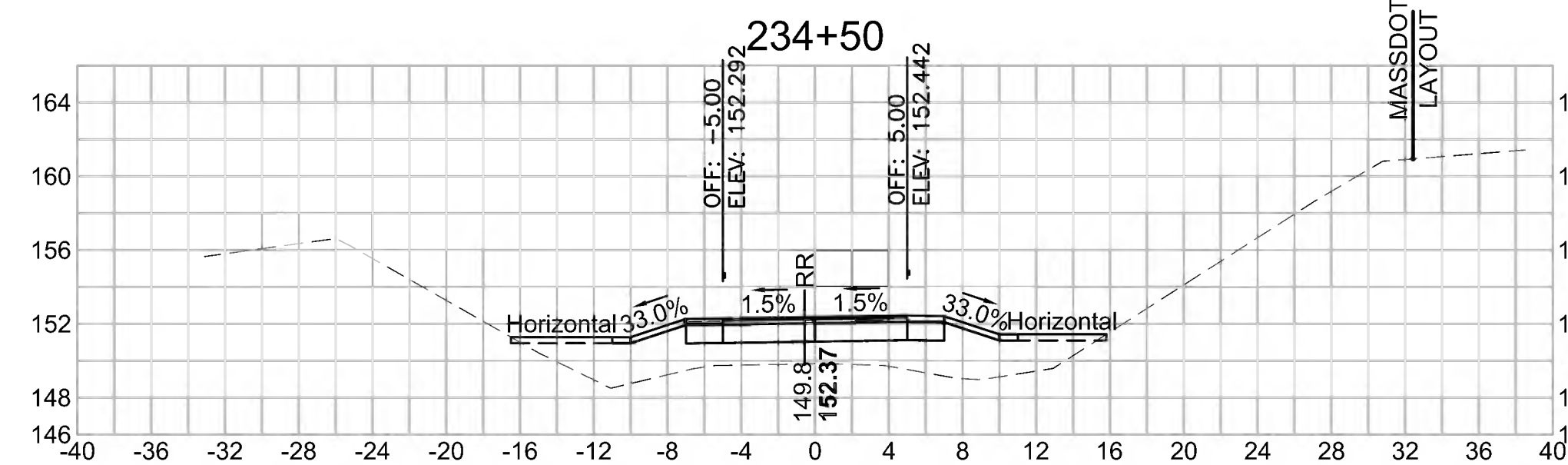

Total Volume at Station 236+00.00

Cut Area (SF)	33.891
Fill Area (SF)	0.000
Cut Vol (CF)	46.5
Fill Vol (CF)	0.5
Cum Cut Vol (CF)	8076.0
Cum Fill Vol (CF)	5680.5
Net Vol (CF)	2395.5

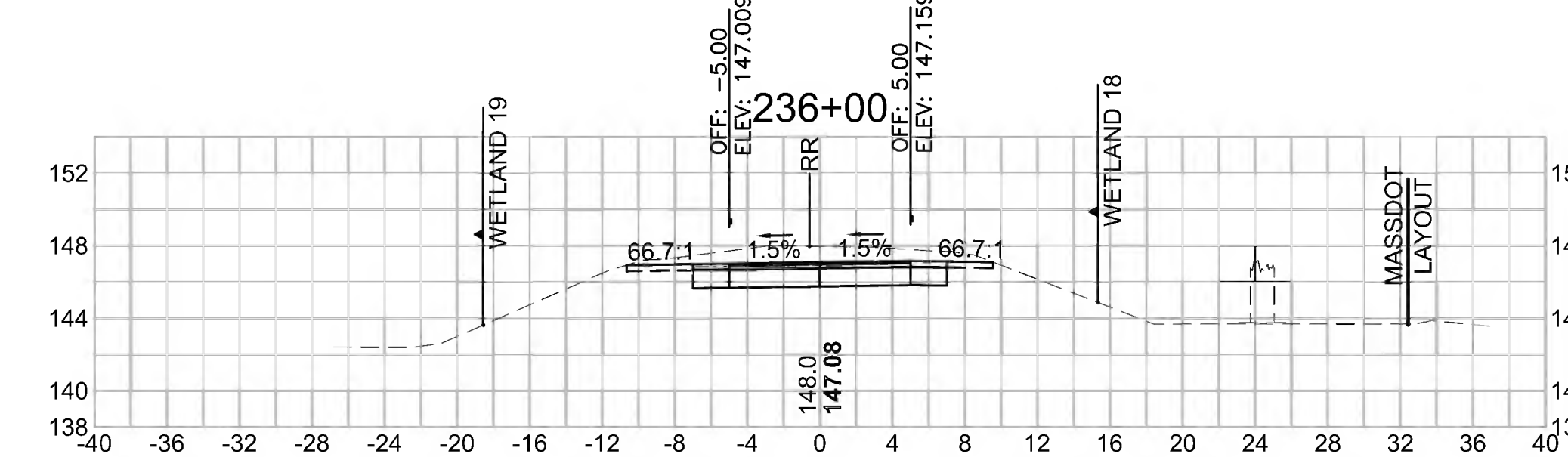

CROSS SECTIONS

Total Volume at Station 238+50.00

Cut Area (SF)	40.123
Fill Area (SF)	0.000
Cut Vol (CF)	72.8
Fill Vol (CF)	0.0
Cum Cut Vol (CF)	8408.5
Cum Fill Vol (CF)	5680.5
Net Vol (CF)	2728.0

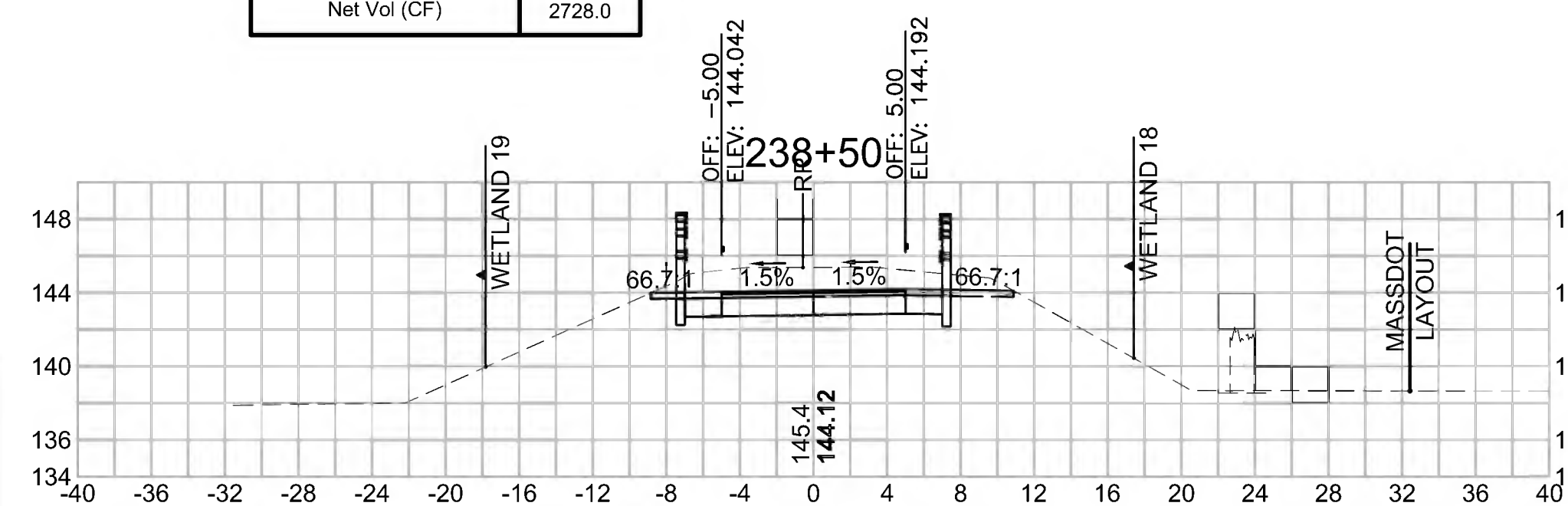

Total Volume at Station 238+00.00

Cut Area (SF)	38.481
Fill Area (SF)	0.000
Cut Vol (CF)	67.4
Fill Vol (CF)	0.0
Cum Cut Vol (CF)	8335.7
Cum Fill Vol (CF)	5680.5
Net Vol (CF)	2655.2

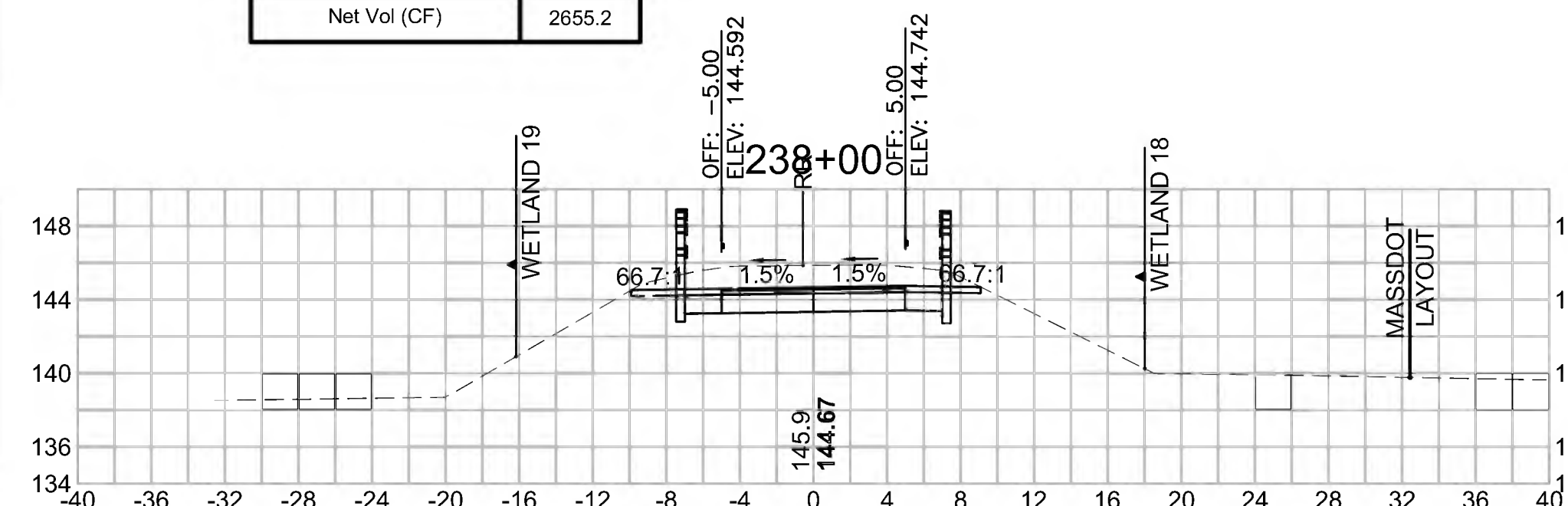

Total Volume at Station 237+50.00

Cut Area (SF)	34.340
Fill Area (SF)	0.000
Cut Vol (CF)	61.0
Fill Vol (CF)	0.0
Cum Cut Vol (CF)	8268.3
Cum Fill Vol (CF)	5680.5
Net Vol (CF)	2587.8

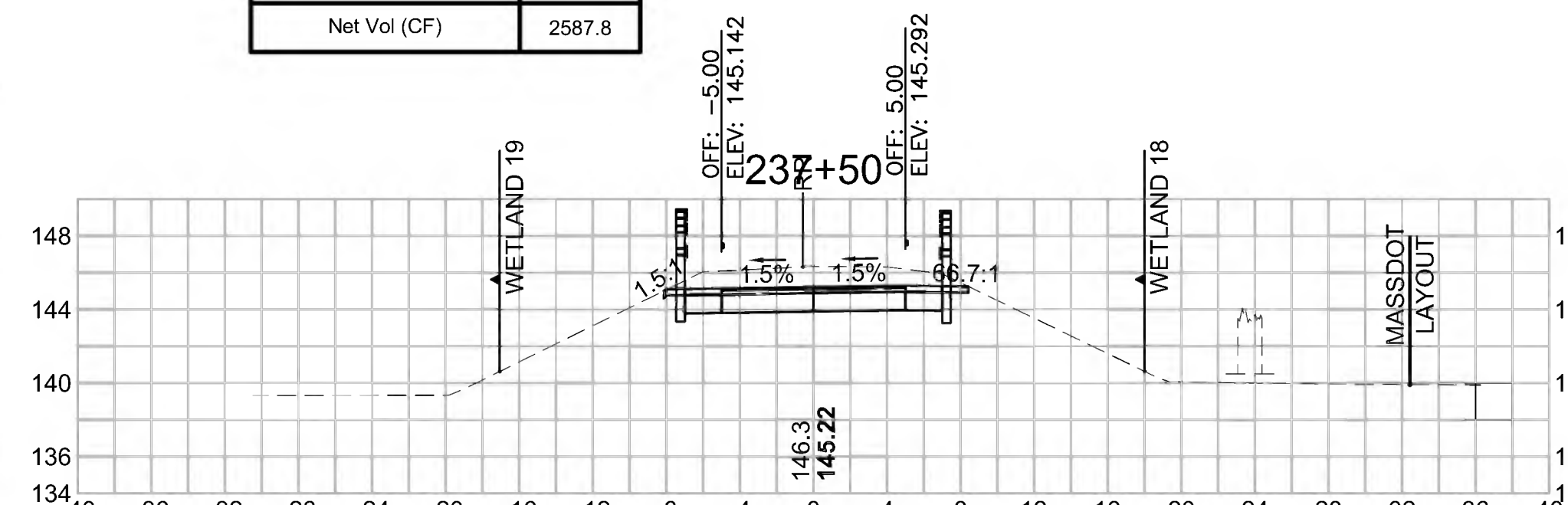

Total Volume at Station 240+00.00

Cut Area (SF)	39.826
Fill Area (SF)	0.000
Cut Vol (CF)	72.7
Fill Vol (CF)	0.0
Cum Cut Vol (CF)	8624.5
Cum Fill Vol (CF)	5680.5
Net Vol (CF)	2944.0

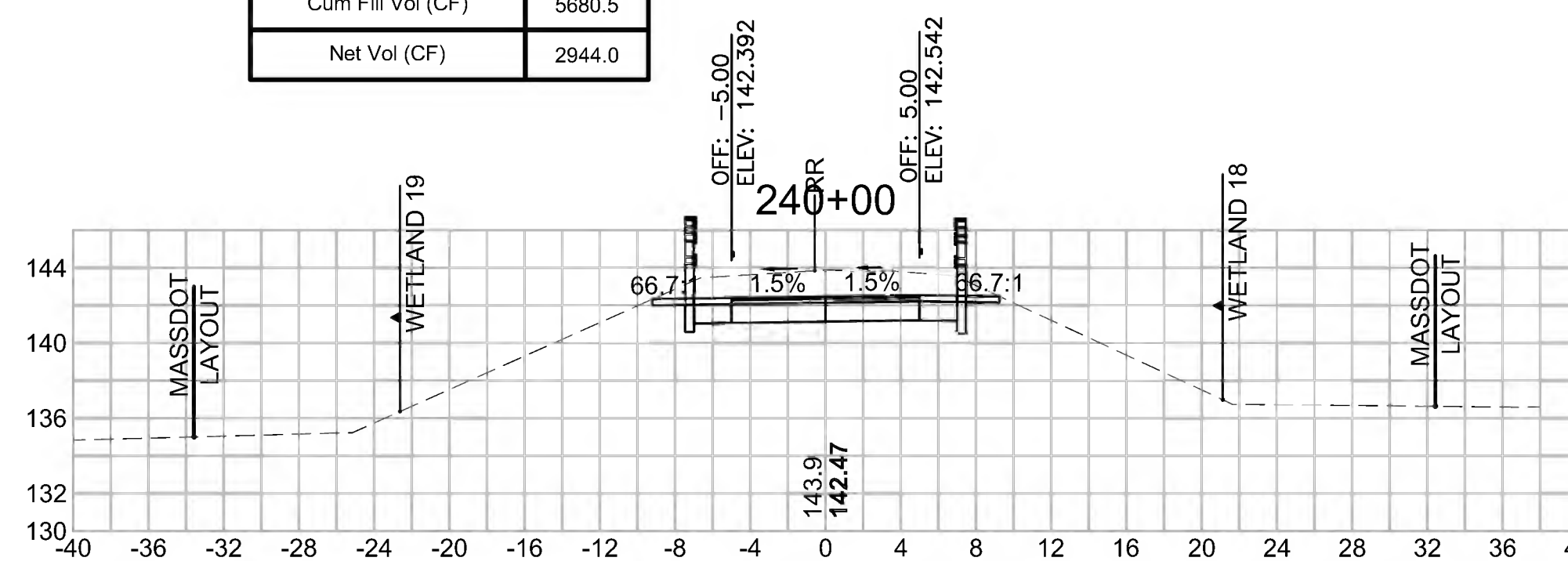

Total Volume at Station 239+50.00

Cut Area (SF)	38.714
Fill Area (SF)	0.000
Cut Vol (CF)	71.0
Fill Vol (CF)	0.0
Cum Cut Vol (CF)	8551.8
Cum Fill Vol (CF)	5680.5
Net Vol (CF)	2871.3

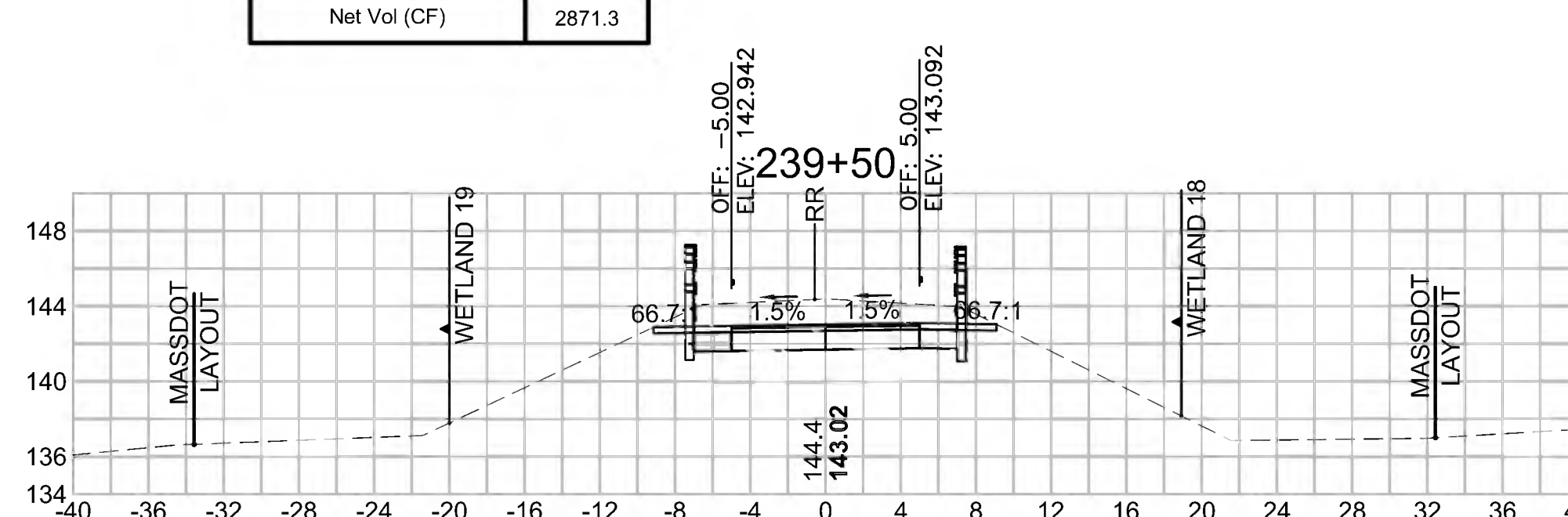

Total Volume at Station 239+00.00

Cut Area (SF)	37.978
Fill Area (SF)	0.000
Cut Vol (CF)	72.3
Fill Vol (CF)	0.0
Cum Cut Vol (CF)	8480.8
Cum Fill Vol (CF)	5680.5
Net Vol (CF)	2800.3

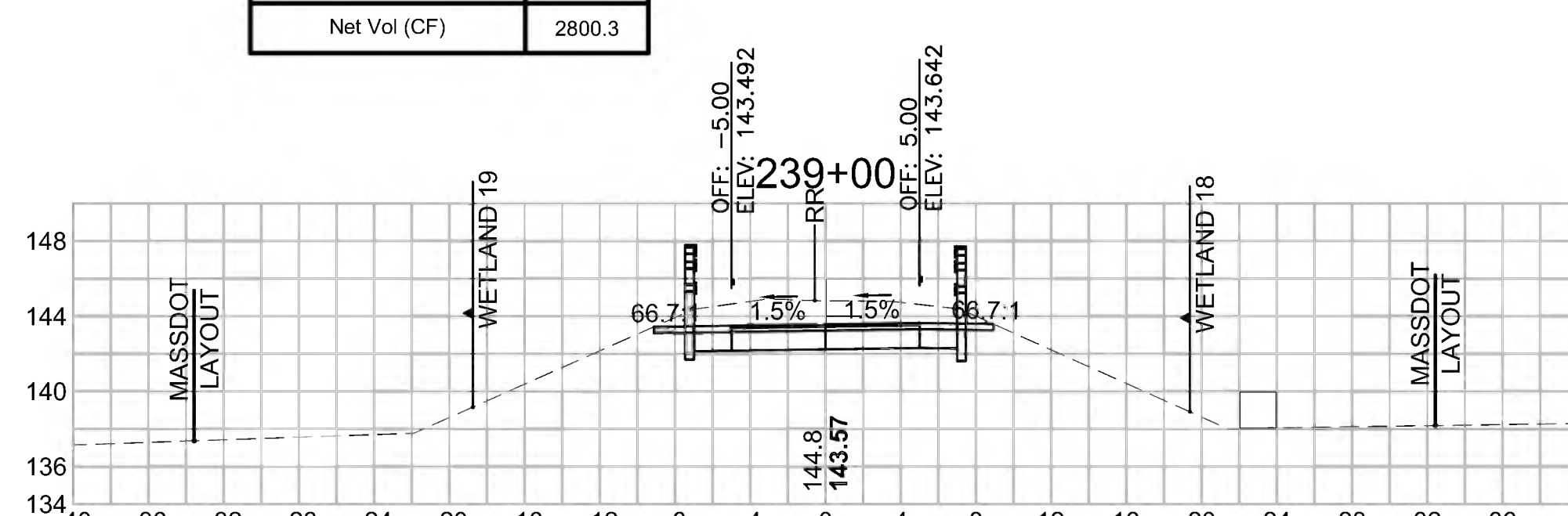

Total Volume at Station 241+50.00

Cut Area (SF)	36.860
Fill Area (SF)	58.543
Cut Vol (CF)	66.2
Fill Vol (CF)	60.7
Cum Cut Vol (CF)	8834.3
Cum Fill Vol (CF)	5747.8
Net Vol (CF)	3086.5

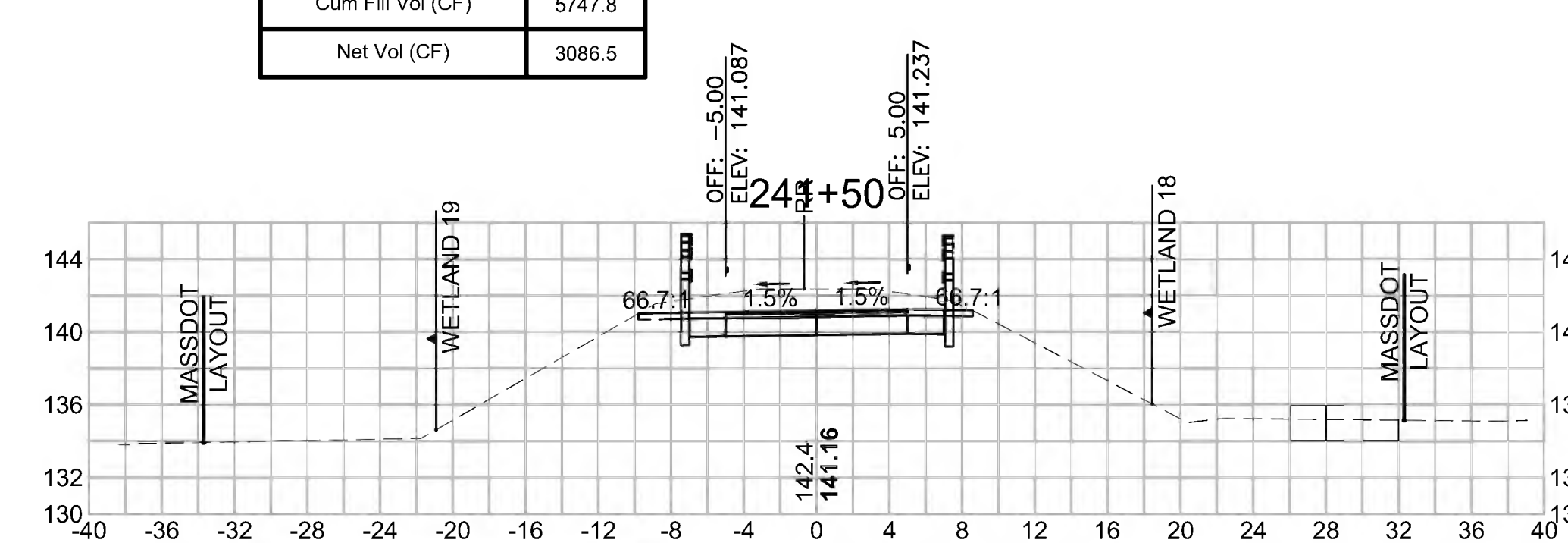

Total Volume at Station 241+00.00

Cut Area (SF)	34.587
Fill Area (SF)	7.031
Cut Vol (CF)	69.4
Fill Vol (CF)	6.5
Cum Cut Vol (CF)	8768.1
Cum Fill Vol (CF)	5687.0
Net Vol (CF)	3081.1

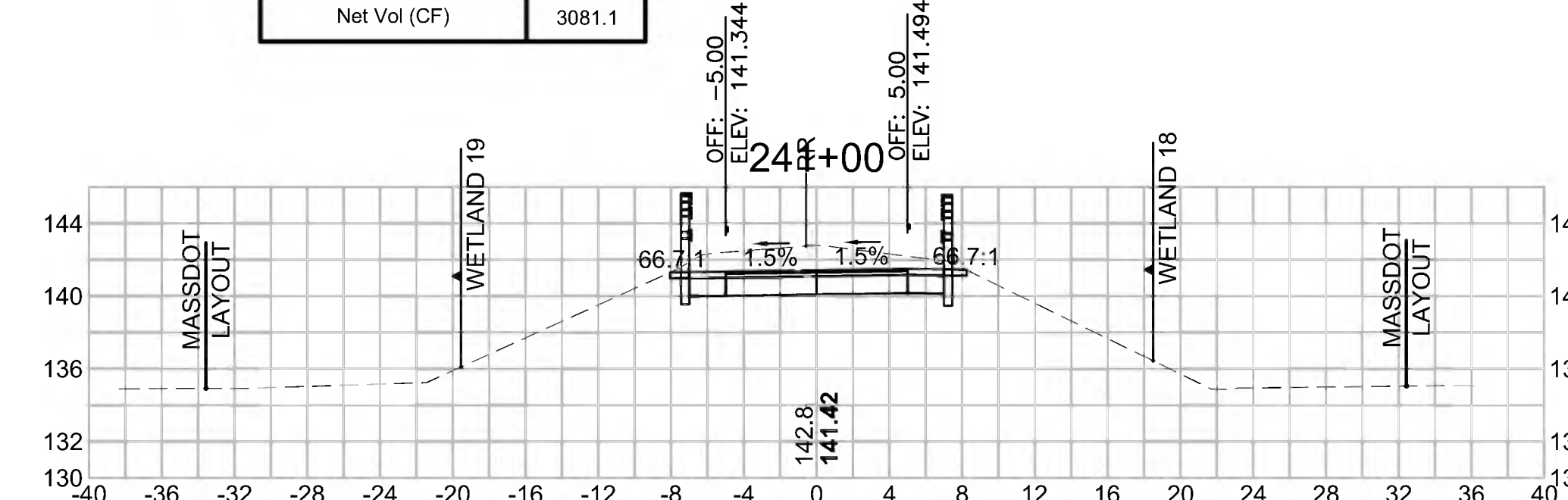

Total Volume at Station 240+50.00

Cut Area (SF)	40.318
Fill Area (SF)	0.000
Cut Vol (CF)	74.2
Fill Vol (CF)	0.0
Cum Cut Vol (CF)	8698.7
Cum Fill Vol (CF)	5680.5
Net Vol (CF)	3018.2

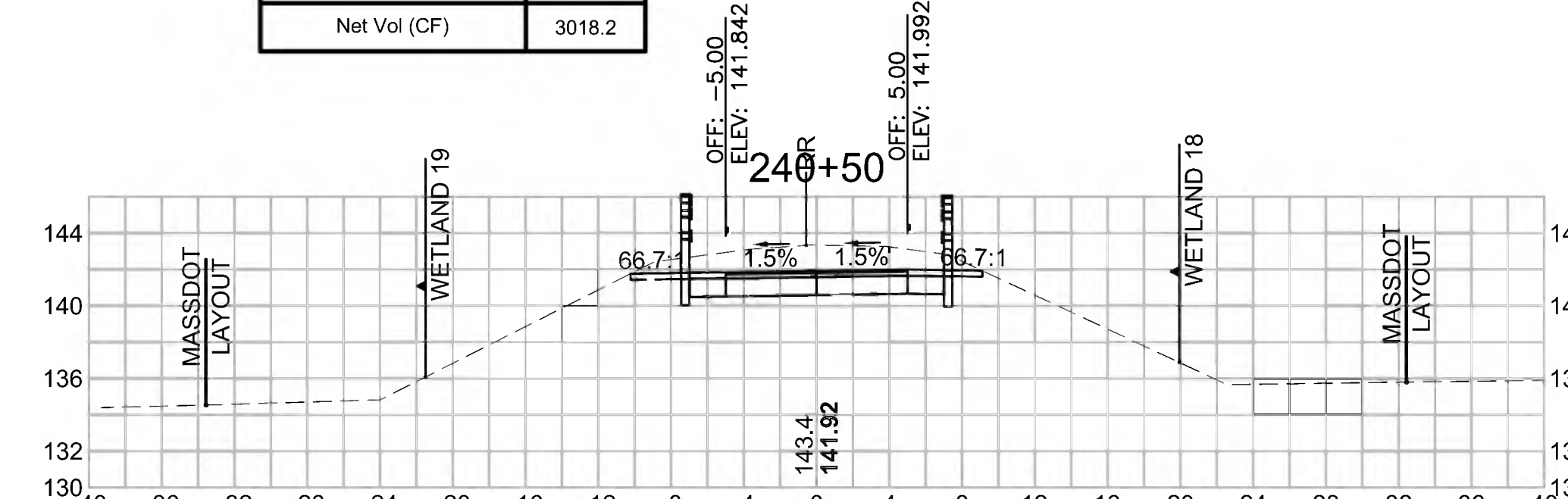

SUDBURY
BRUCE FREEMAN RAIL TRAIL

STATE	FED. AID PROJ. NO.	SHEET NO.	TOTAL SHEETS
MA	XXX-XXXX(XXX)X	279	319

PROJECT FILE NO. 608164

CROSS SECTIONS

Total Volume at Station 243+00.00

Cut Area (SF)	46.014
Fill Area (SF)	9.458
Cut Vol (CF)	95.3
Fill Vol (CF)	18.8
Cum Cut Vol (CF)	9091.5
Cum Fill Vol (CF)	5862.3
Net Vol (CF)	3229.2

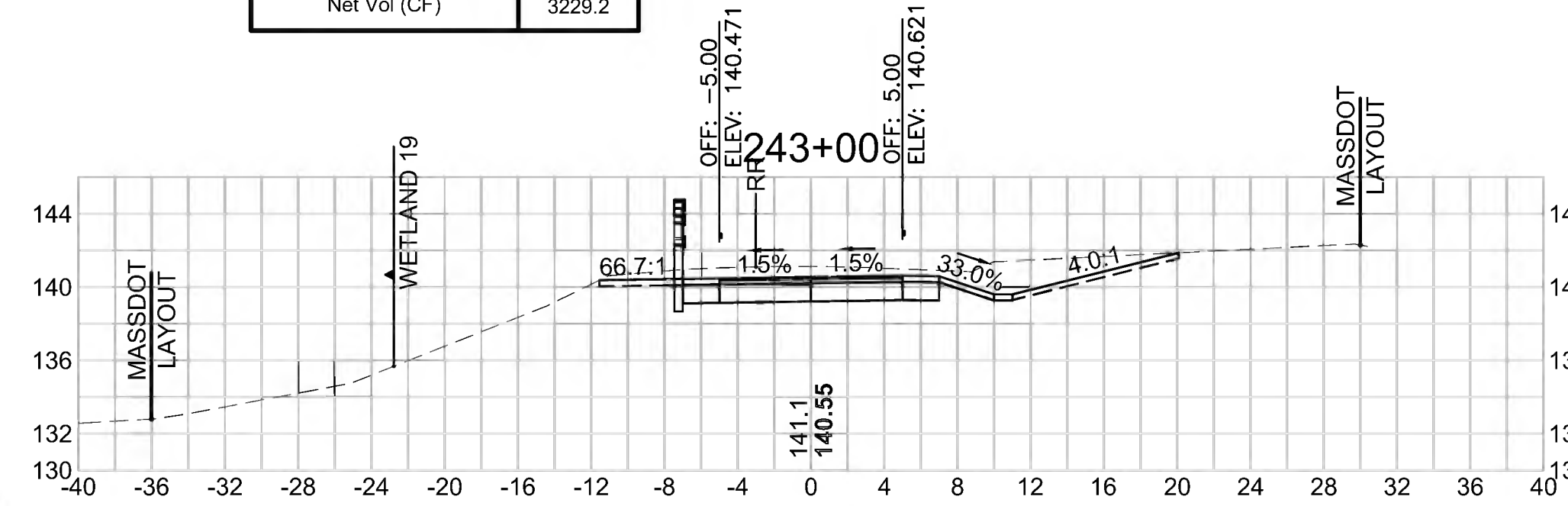

Total Volume at Station 244+50.00

Cut Area (SF)	14.460
Fill Area (SF)	3.195
Cut Vol (CF)	32.6
Fill Vol (CF)	3.1
Cum Cut Vol (CF)	9264.2
Cum Fill Vol (CF)	5874.2
Net Vol (CF)	3390.0

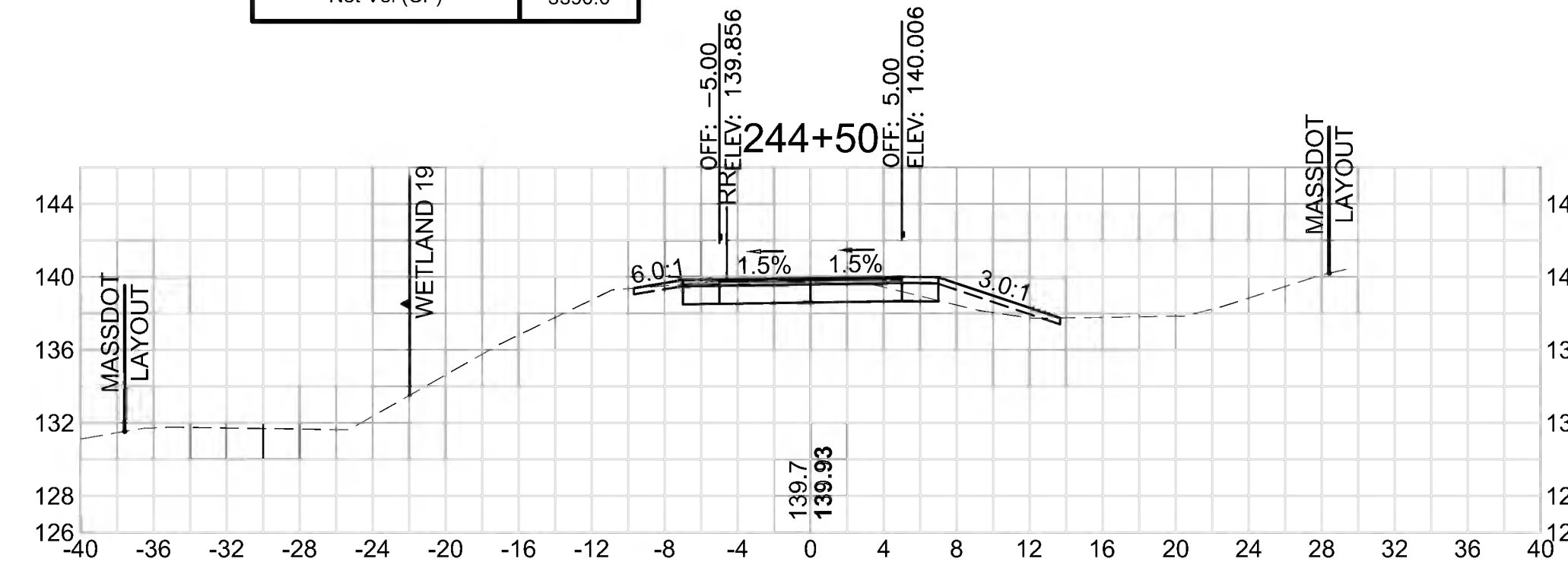

Total Volume at Station 246+00.00

Cut Area (SF)	17.273
Fill Area (SF)	2.105
Cut Vol (CF)	27.2
Fill Vol (CF)	10.7
Cum Cut Vol (CF)	9348.1
Cum Fill Vol (CF)	5898.3
Net Vol (CF)	3449.7

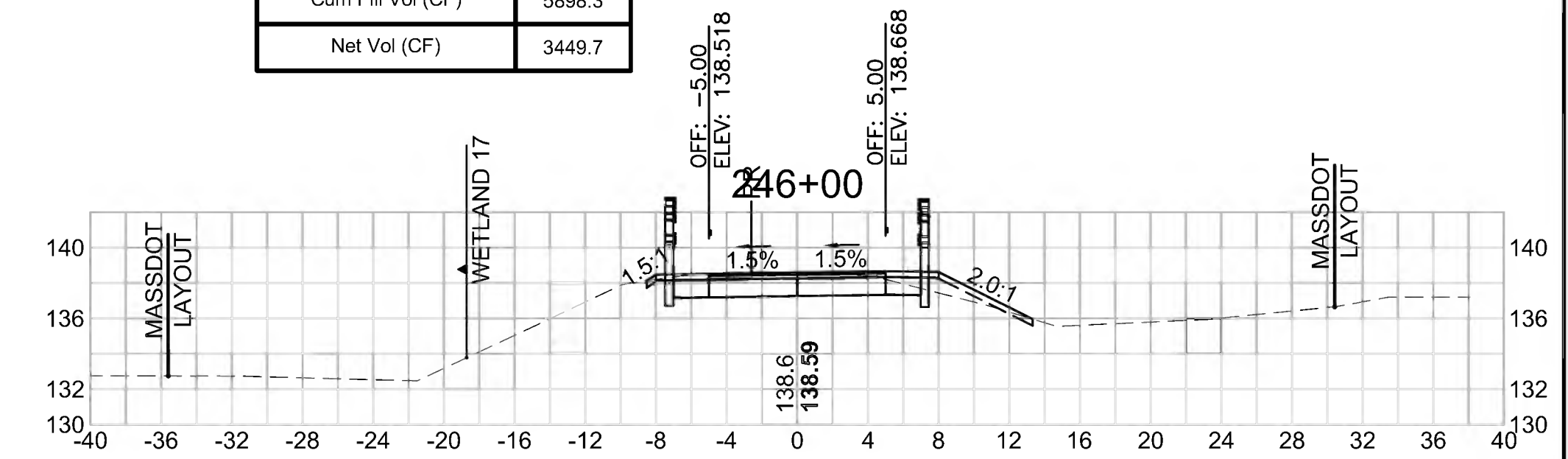

Total Volume at Station 242+50.00

Cut Area (SF)	56.932
Fill Area (SF)	10.847
Cut Vol (CF)	90.3
Fill Vol (CF)	25.8
Cum Cut Vol (CF)	8996.2
Cum Fill Vol (CF)	5843.5
Net Vol (CF)	3152.7

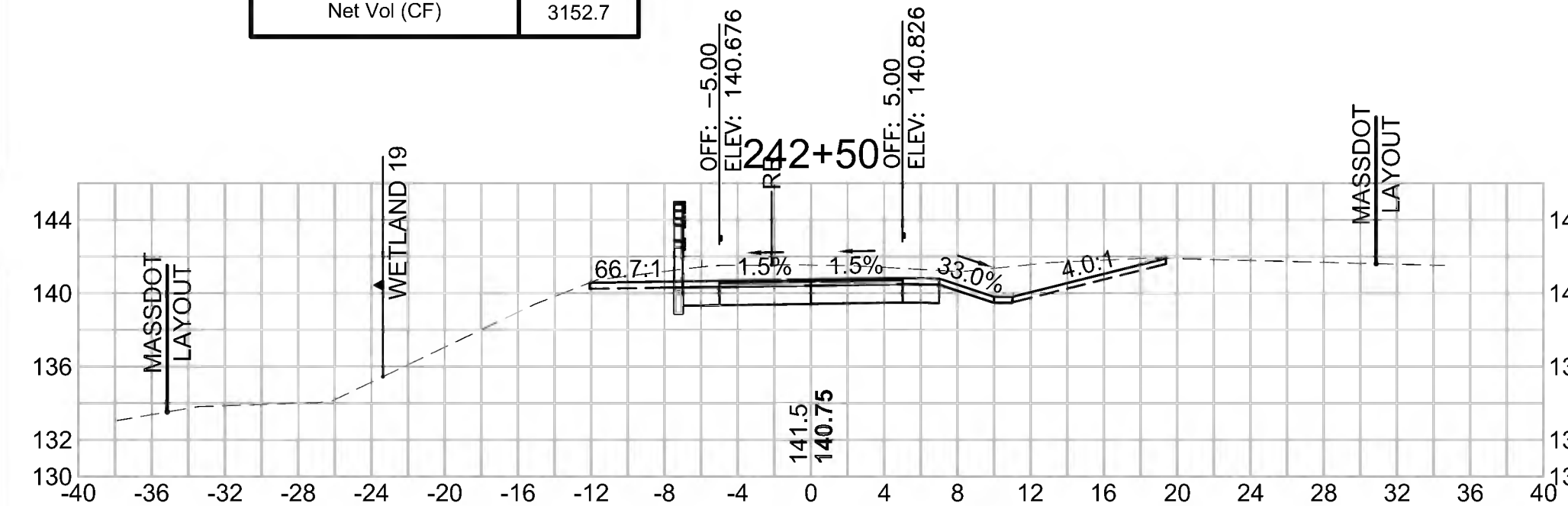

Total Volume at Station 244+00.00

Cut Area (SF)	20.739
Fill Area (SF)	0.105
Cut Vol (CF)	58.3
Fill Vol (CF)	0.1
Cum Cut Vol (CF)	9231.6
Cum Fill Vol (CF)	5871.1
Net Vol (CF)	3360.5

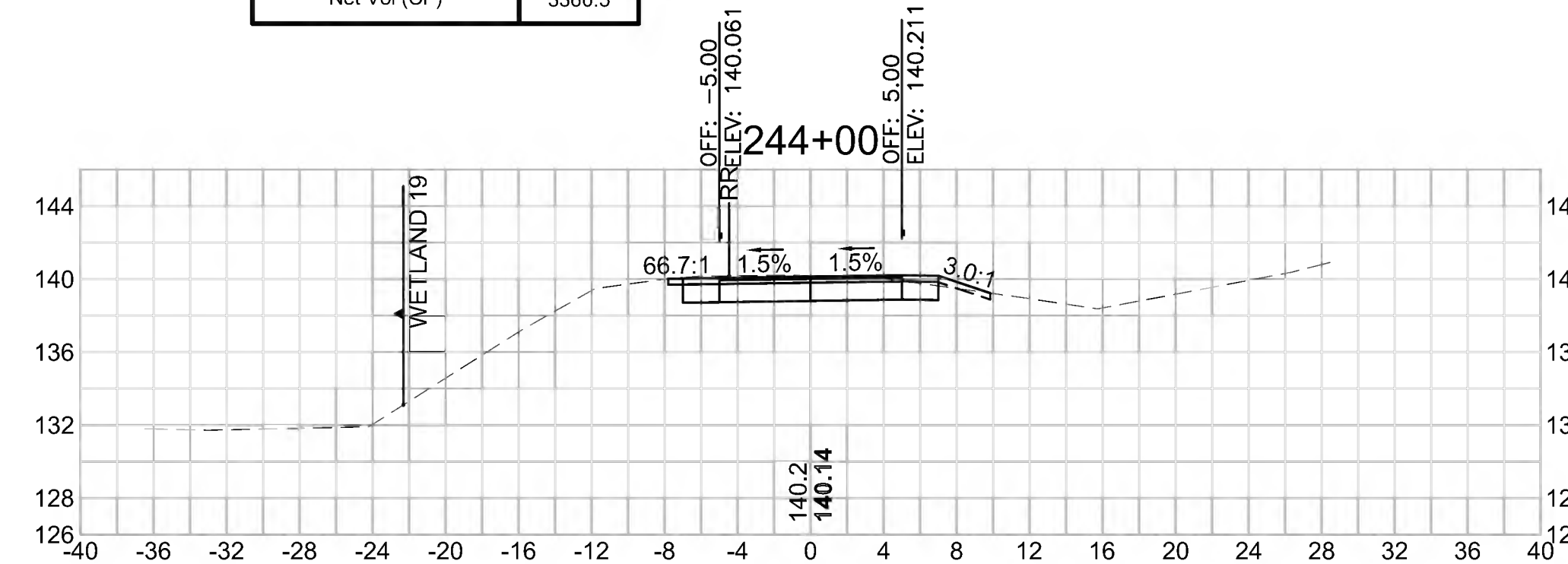

Total Volume at Station 245+50.00

Cut Area (SF)	12.126
Fill Area (SF)	9.499
Cut Vol (CF)	27.3
Fill Vol (CF)	9.6
Cum Cut Vol (CF)	9320.8
Cum Fill Vol (CF)	5887.6
Net Vol (CF)	3433.2

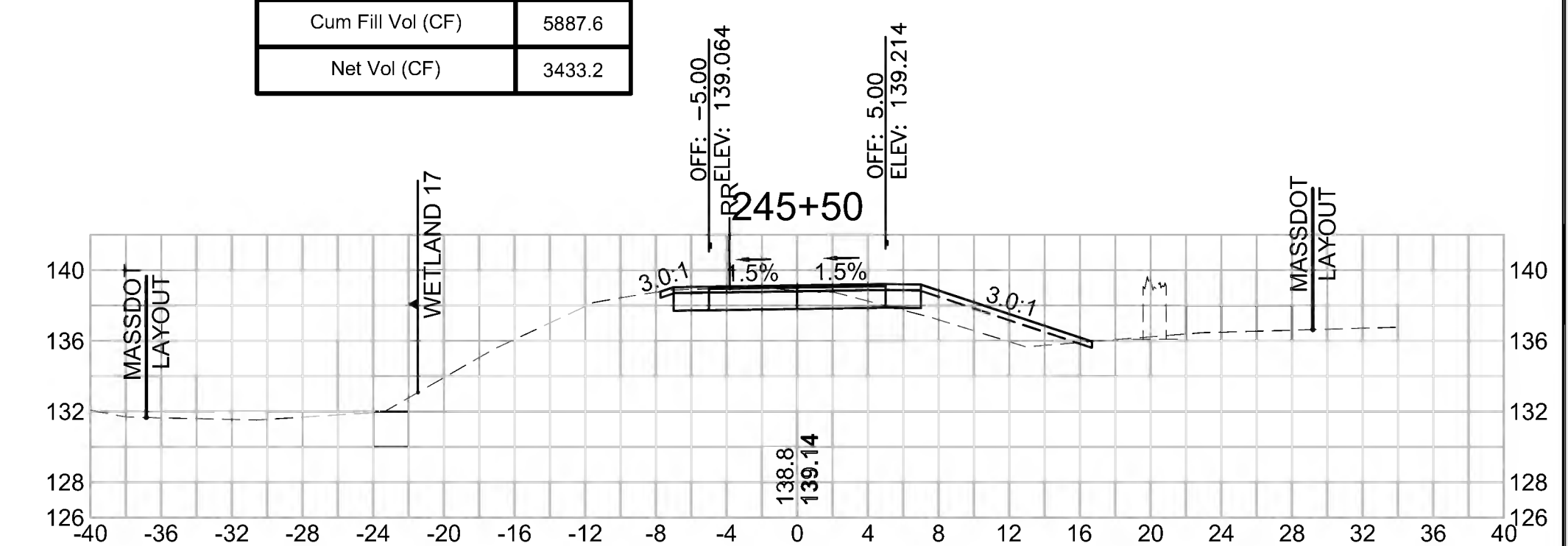

Total Volume at Station 242+00.00

Cut Area (SF)	40.540
Fill Area (SF)	16.985
Cut Vol (CF)	71.7
Fill Vol (CF)	69.9
Cum Cut Vol (CF)	8905.9
Cum Fill Vol (CF)	5817.7
Net Vol (CF)	3088.2

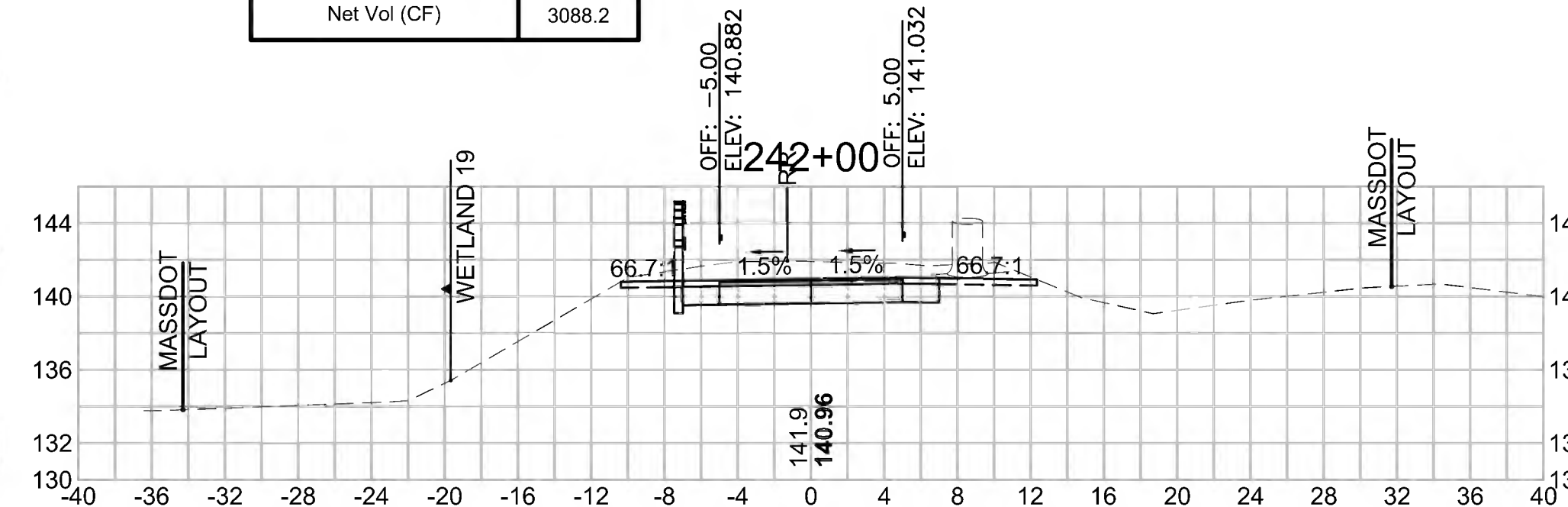

Total Volume at Station 243+50.00

Cut Area (SF)	42.264
Fill Area (SF)	0.003
Cut Vol (CF)	81.7
Fill Vol (CF)	8.8
Cum Cut Vol (CF)	9173.2
Cum Fill Vol (CF)	5871.0
Net Vol (CF)	3302.2

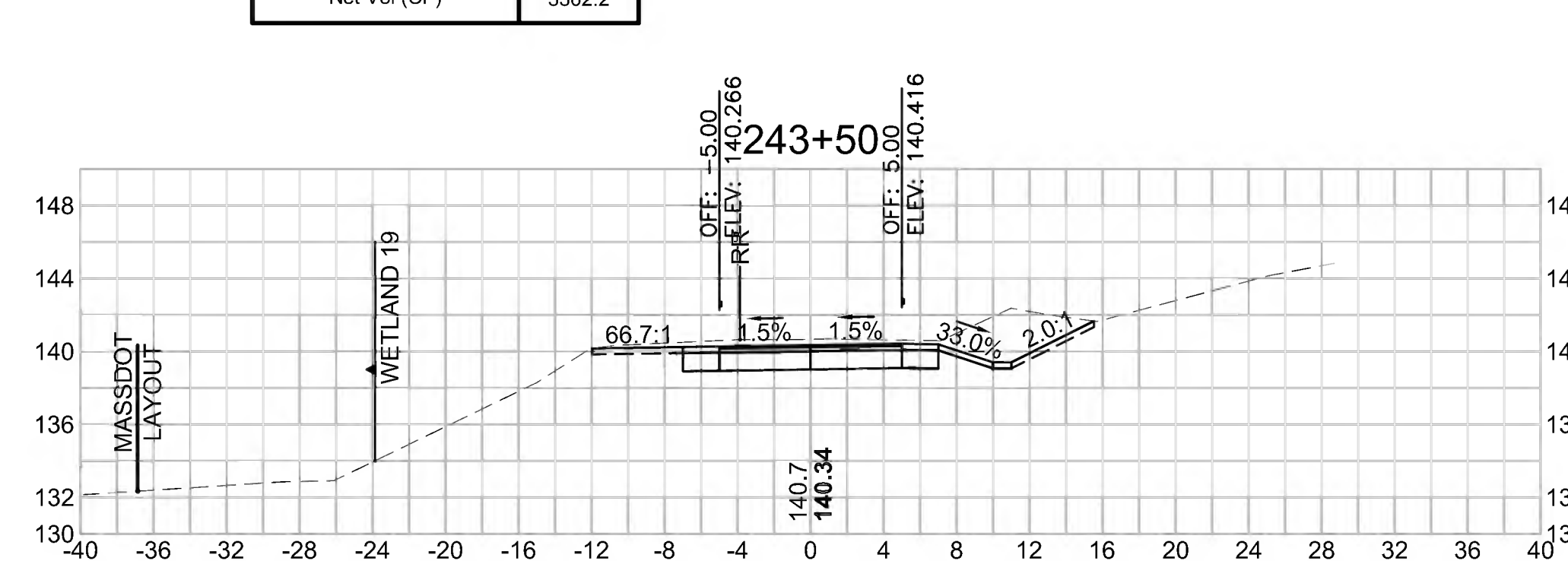

Total Volume at Station 245+00.00

Cut Area (SF)	17.312
Fill Area (SF)	0.900
Cut Vol (CF)	29.4
Fill Vol (CF)	3.8
Cum Cut Vol (CF)	9293.6
Cum Fill Vol (CF)	5878.0
Net Vol (CF)	3415.6

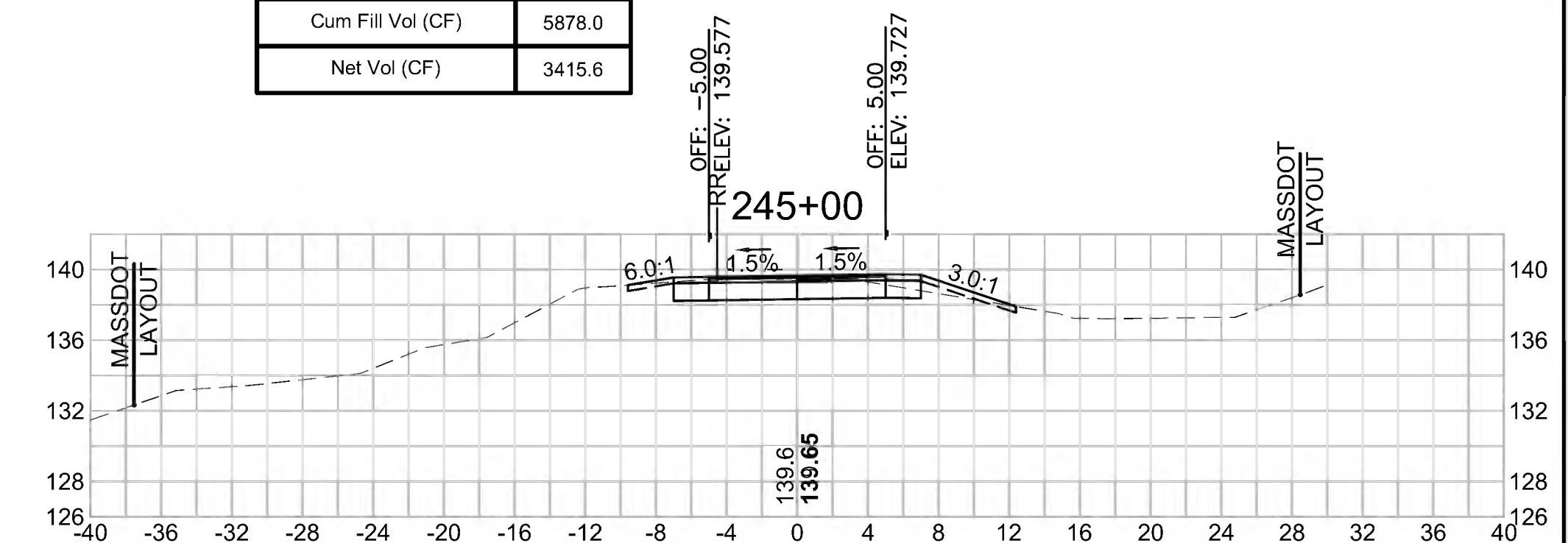

SUDBURY
BRUCE FREEMAN RAIL TRAIL

STATE	FED. AID PROJ. NO.	SHEET NO.	TOTAL SHEETS
MA	XXX-XXXX(XXX)X	280	319

PROJECT FILE NO. 608164

CROSS SECTIONS

Total Volume at Station 247+50.00

Cut Area (SF)	27.970
Fill Area (SF)	10.437
Cut Vol (CF)	51.2
Fill Vol (CF)	9.7
Cum Cut Vol (CF)	9480.9
Cum Fill Vol (CF)	5910.0
Net Vol (CF)	3571.0

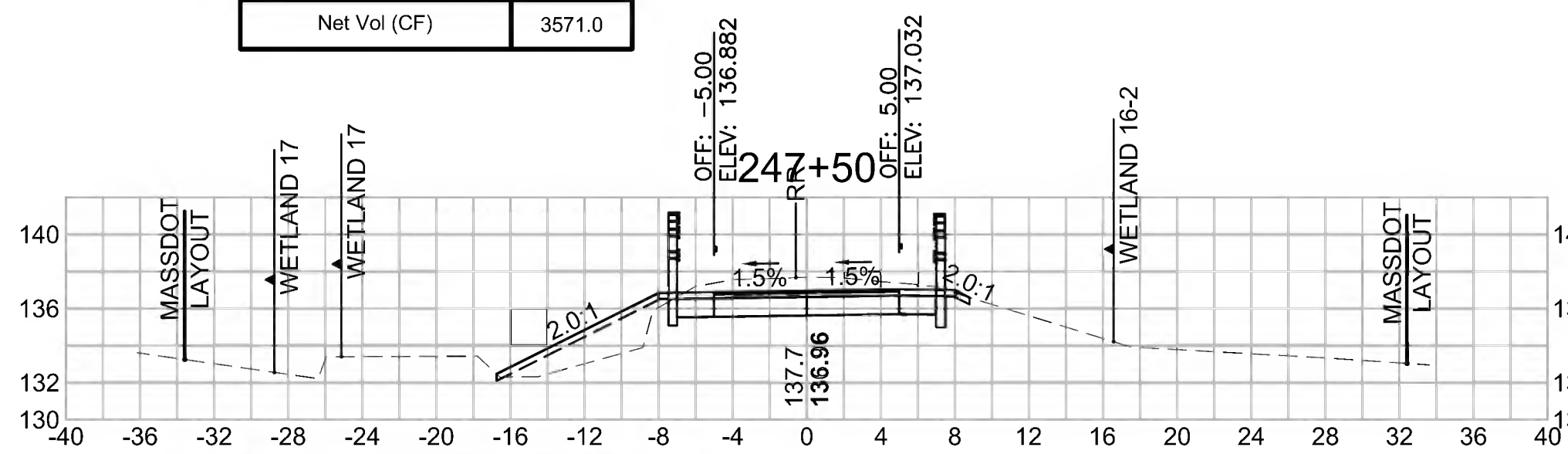

Total Volume at Station 249+00.00

Cut Area (SF)	19.014
Fill Area (SF)	0.000
Cut Vol (CF)	41.9
Fill Vol (CF)	0.0
Cum Cut Vol (CF)	9635.3
Cum Fill Vol (CF)	5919.6
Net Vol (CF)	3715.6

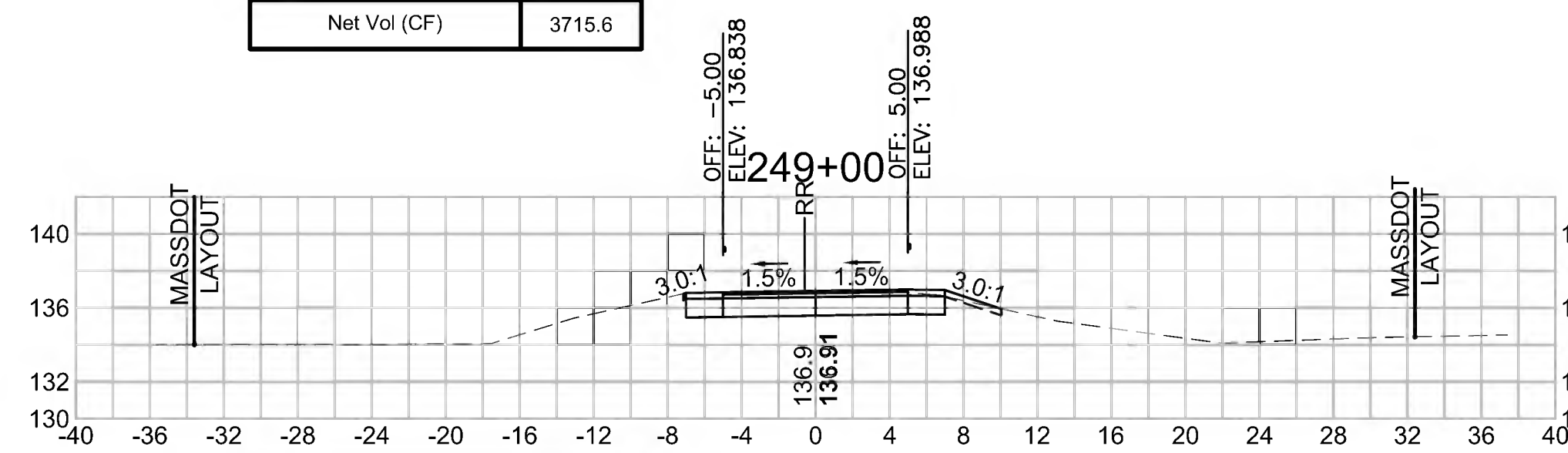

Total Volume at Station 250+50.00

Cut Area (SF)	18.871
Fill Area (SF)	7.482
Cut Vol (CF)	25.1
Fill Vol (CF)	8.6
Cum Cut Vol (CF)	9709.5
Cum Fill Vol (CF)	5930.2
Net Vol (CF)	3779.2

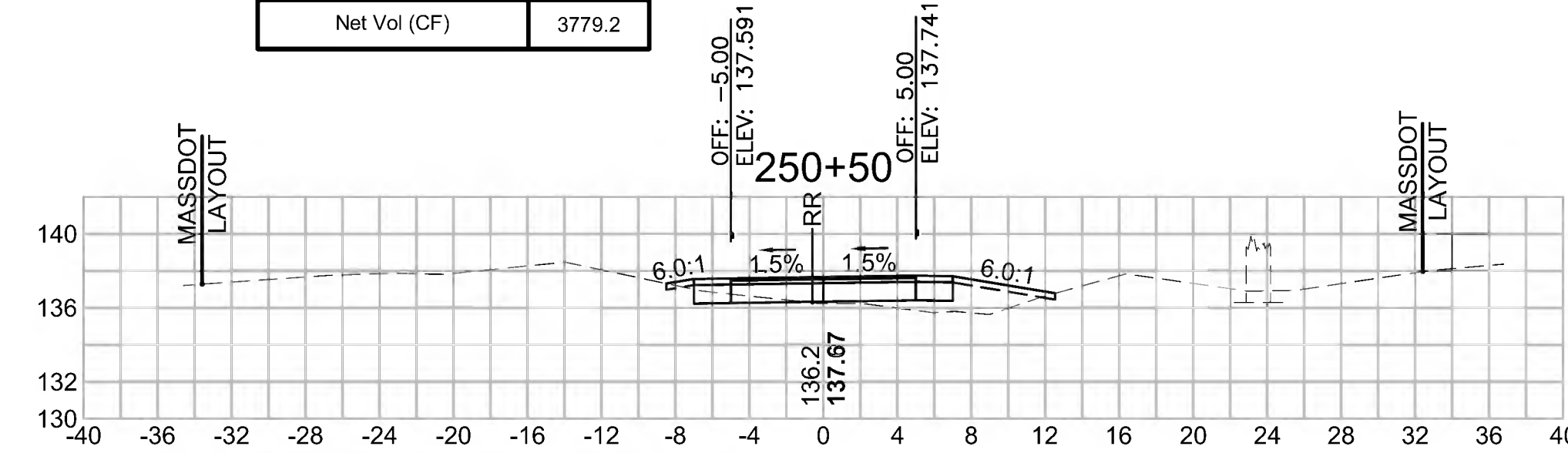

Total Volume at Station 247+00.00

Cut Area (SF)	27.272
Fill Area (SF)	0.011
Cut Vol (CF)	45.5
Fill Vol (CF)	0.0
Cum Cut Vol (CF)	9429.8
Cum Fill Vol (CF)	5900.3
Net Vol (CF)	3529.5

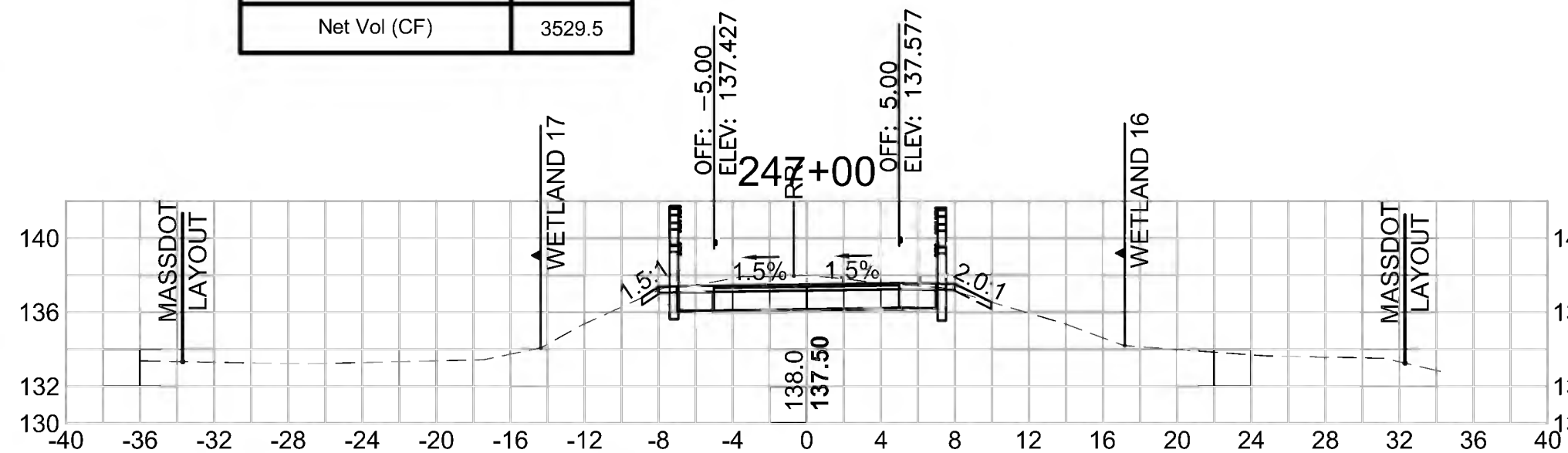

Total Volume at Station 248+50.00

Cut Area (SF)	26.248
Fill Area (SF)	0.000
Cut Vol (CF)	55.4
Fill Vol (CF)	0.0
Cum Cut Vol (CF)	9593.4
Cum Fill Vol (CF)	5919.6
Net Vol (CF)	3673.7

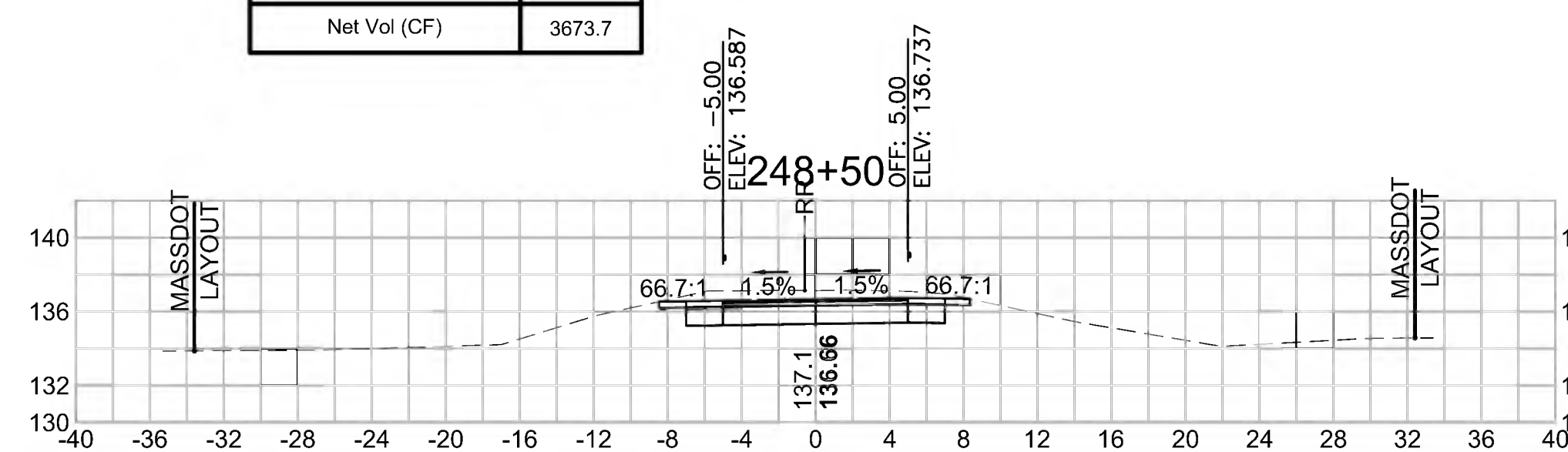

Total Volume at Station 250+00.00

Cut Area (SF)	8.194
Fill Area (SF)	1.778
Cut Vol (CF)	19.6
Fill Vol (CF)	1.8
Cum Cut Vol (CF)	9684.4
Cum Fill Vol (CF)	5921.6
Net Vol (CF)	3762.8

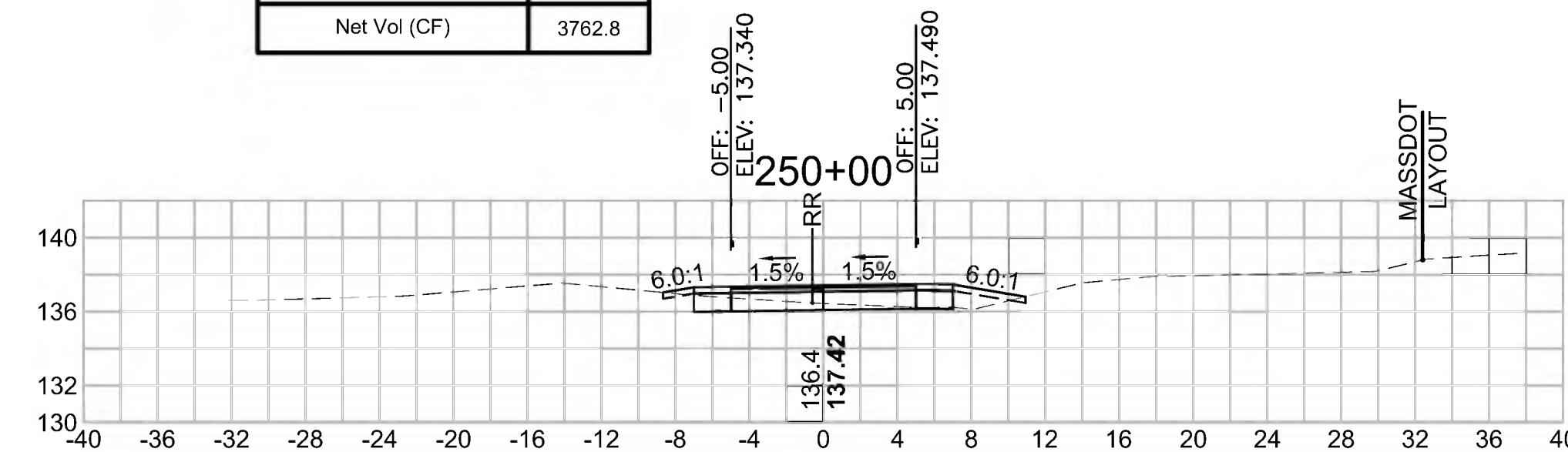

Total Volume at Station 246+50.00

Cut Area (SF)	21.860
Fill Area (SF)	0.001
Cut Vol (CF)	36.2
Fill Vol (CF)	1.9
Cum Cut Vol (CF)	9384.3
Cum Fill Vol (CF)	5900.3
Net Vol (CF)	3484.0

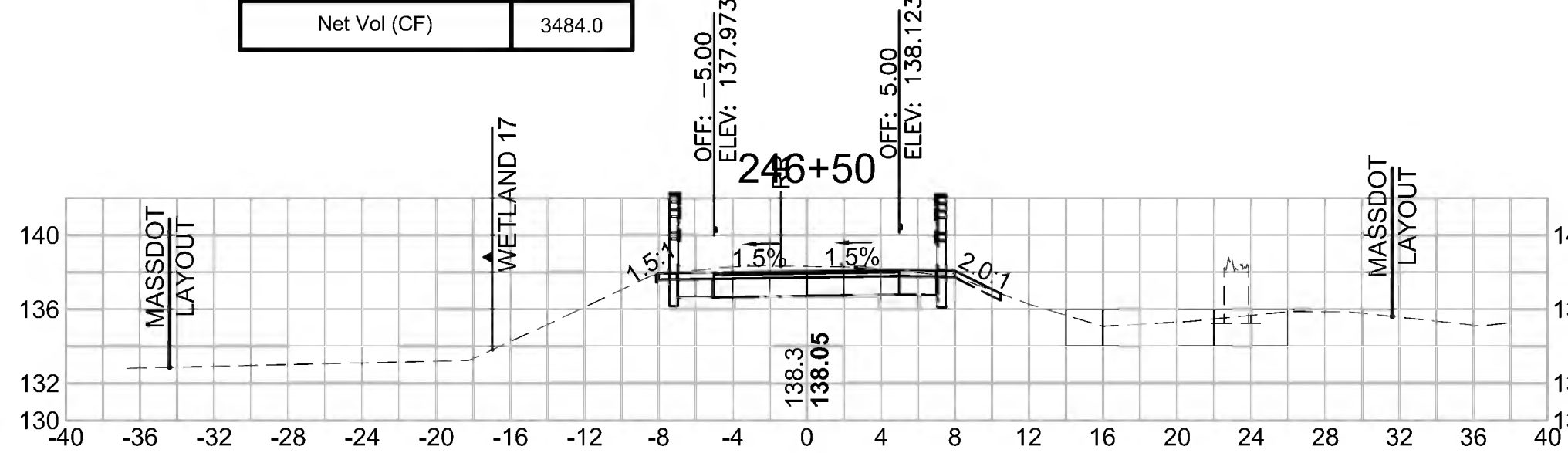

Total Volume at Station 248+00.00

Cut Area (SF)	33.601
Fill Area (SF)	0.000
Cut Vol (CF)	57.0
Fill Vol (CF)	9.7
Cum Cut Vol (CF)	9537.9
Cum Fill Vol (CF)	5919.6
Net Vol (CF)	3618.3

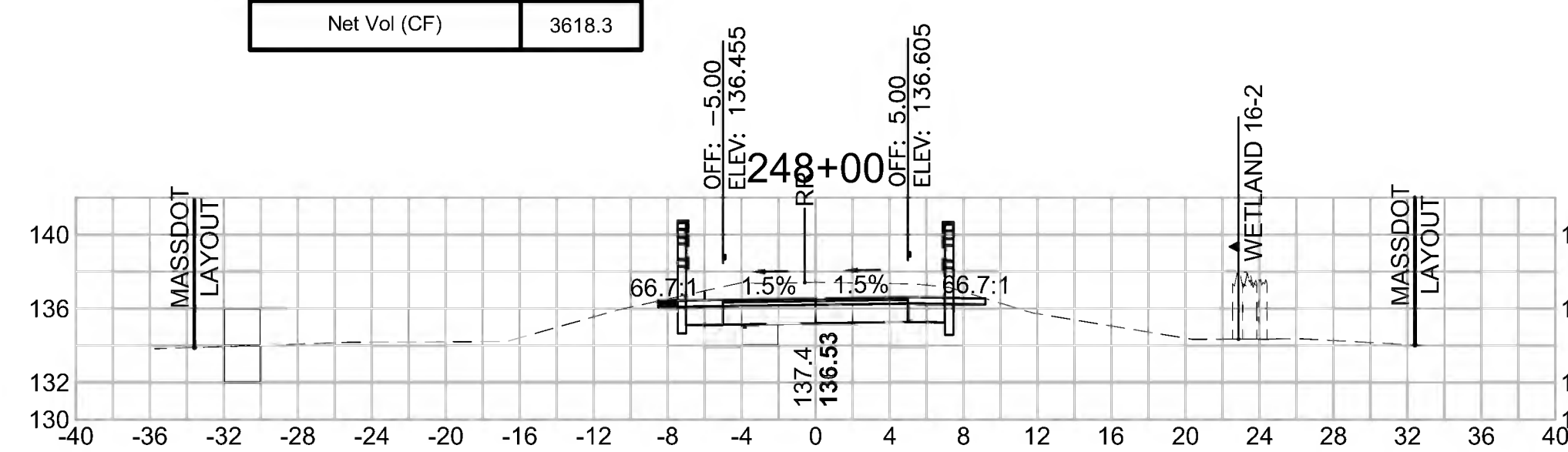

Total Volume at Station 249+50.00

Cut Area (SF)	12.926
Fill Area (SF)	0.194
Cut Vol (CF)	29.6
Fill Vol (CF)	0.2
Cum Cut Vol (CF)	9664.8
Cum Fill Vol (CF)	5919.8
Net Vol (CF)	3745.0

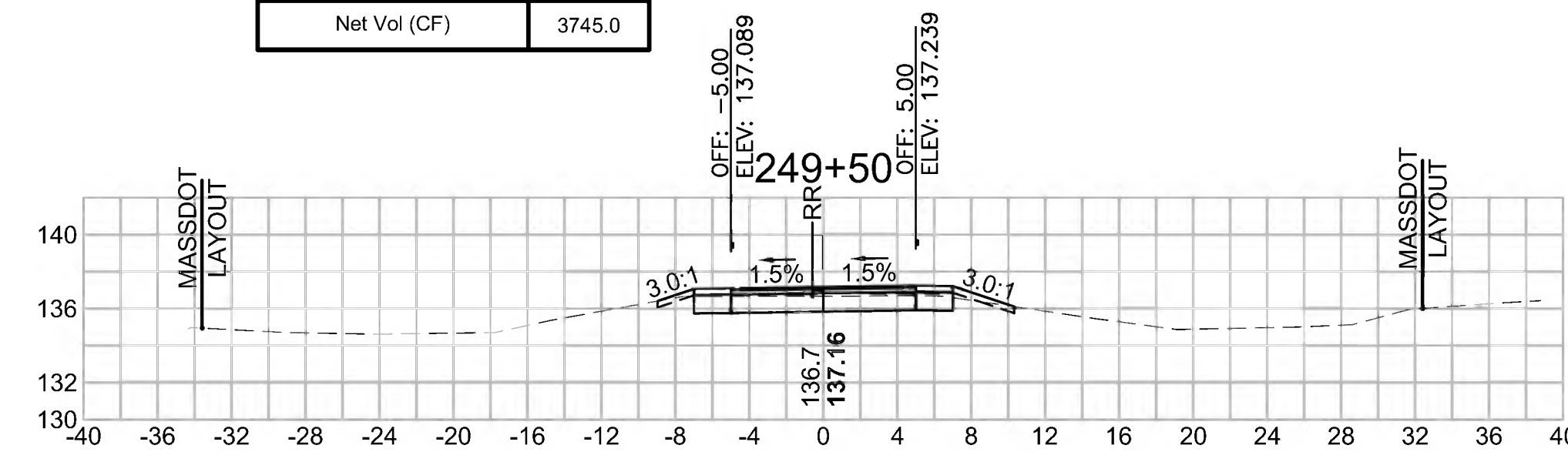

SUDBURY
BRUCE FREEMAN RAIL TRAIL

STATE	FED. AID PROJ. NO.	SHEET NO.	TOTAL SHEETS
MA	XXX-XXX(XXX)X	281	319

PROJECT FILE NO. 608164

CROSS SECTIONS

608164_XSEC(CROSS SECTION LAYOUTS).DWG 18-Feb-2022

Total Volume at Station 252+00.00

Cut Area (SF)	0.630
Fill Area (SF)	45.112
Cut Vol (CF)	3.5
Fill Vol (CF)	76.7
Cum Cut Vol (CF)	9735.9
Cum Fill Vol (CF)	6114.6
Net Vol (CF)	3621.3

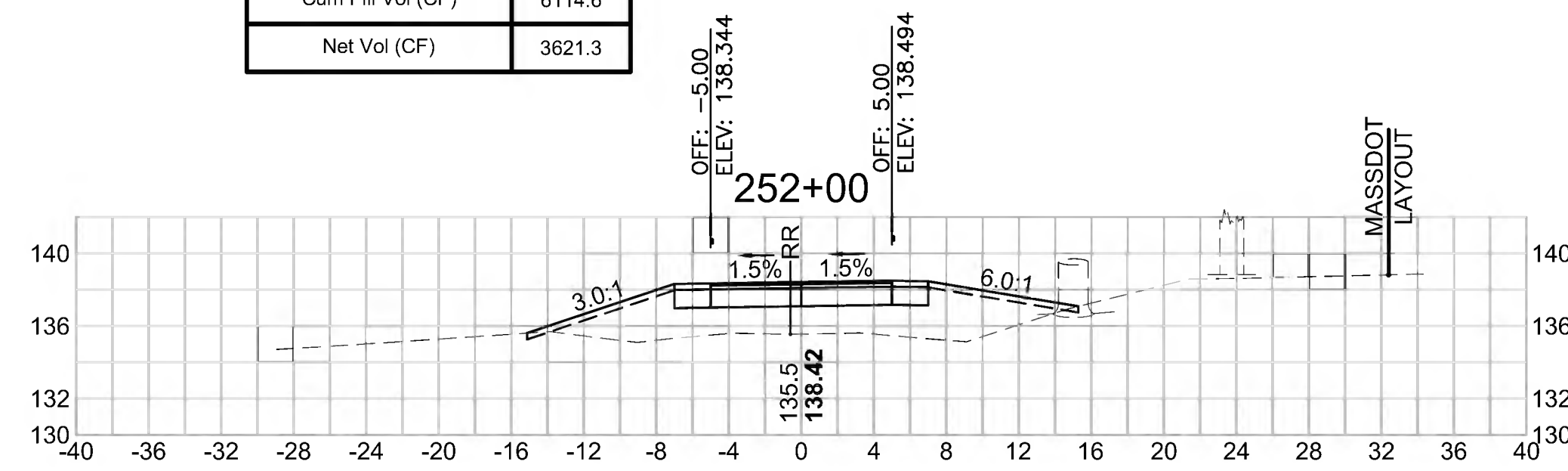

Total Volume at Station 253+50.00

Cut Area (SF)	0.229
Fill Area (SF)	83.655
Cut Vol (CF)	0.5
Fill Vol (CF)	144.9
Cum Cut Vol (CF)	9738.9
Cum Fill Vol (CF)	6469.4
Net Vol (CF)	3269.4

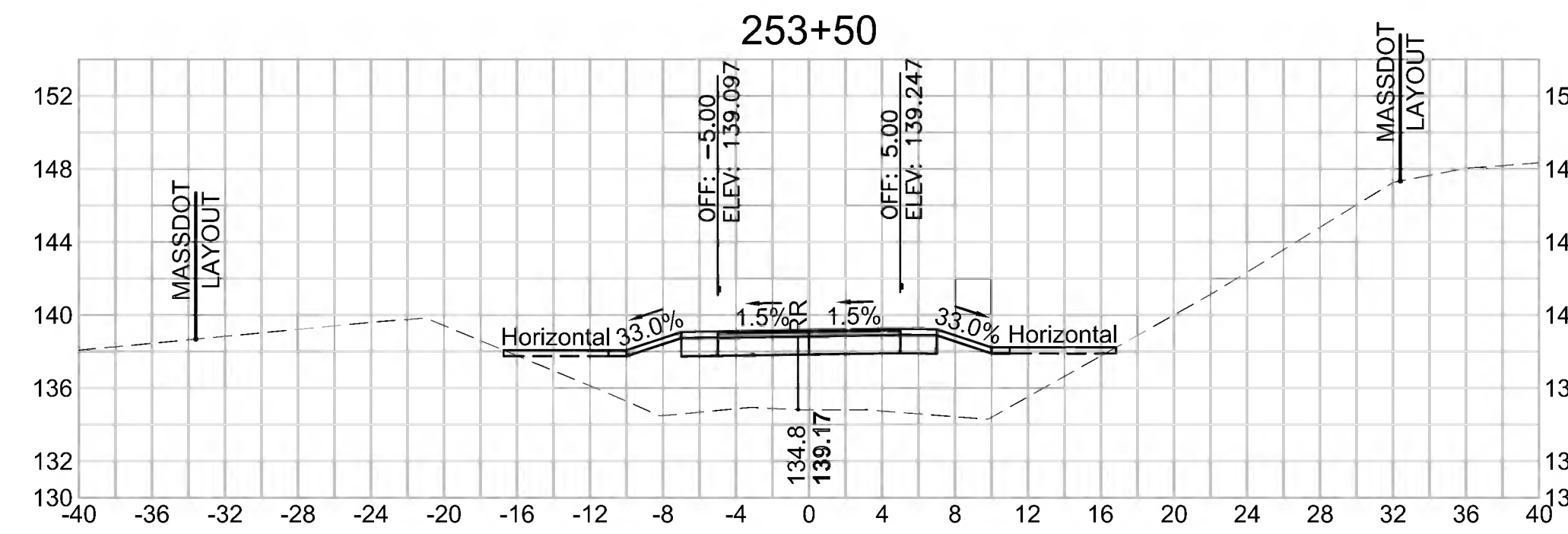

Total Volume at Station 255+00.00

Cut Area (SF)	0.858
Fill Area (SF)	119.067
Cut Vol (CF)	1.0
Fill Vol (CF)	219.6
Cum Cut Vol (CF)	9740.6
Cum Fill Vol (CF)	7065.1
Net Vol (CF)	2675.6

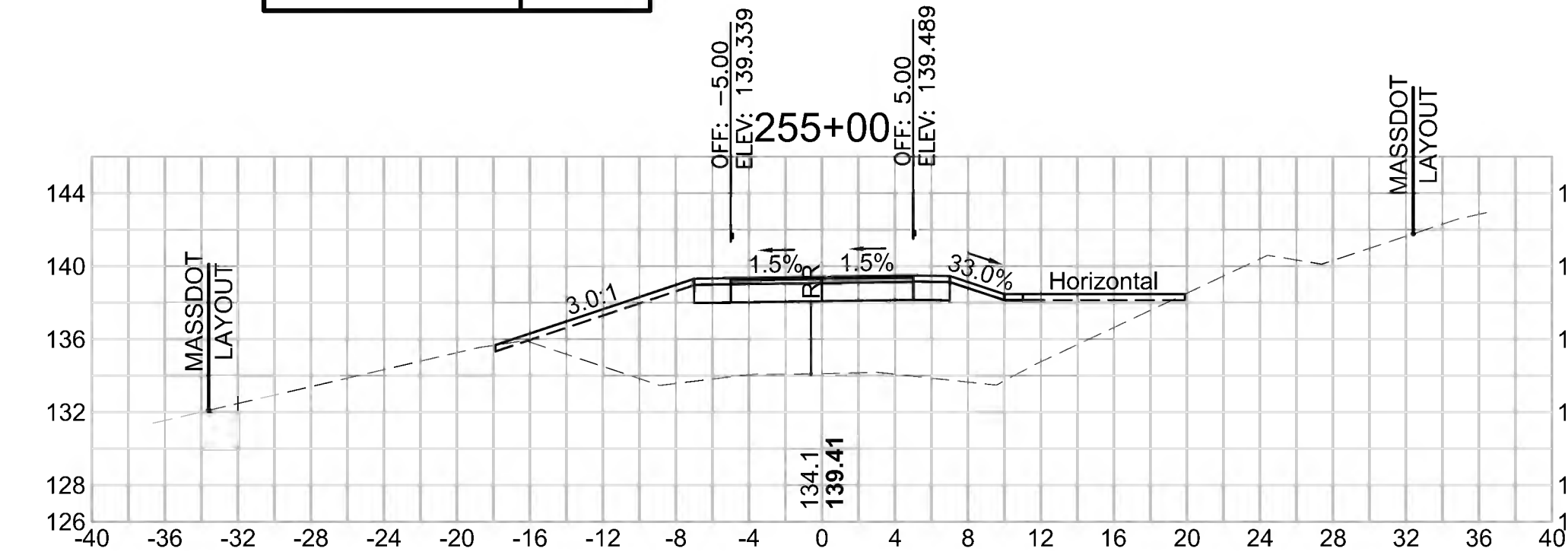

Total Volume at Station 251+50.00

Cut Area (SF)	3.142
Fill Area (SF)	37.729
Cut Vol (CF)	4.2
Fill Vol (CF)	67.9
Cum Cut Vol (CF)	9732.4
Cum Fill Vol (CF)	6037.9
Net Vol (CF)	3694.5

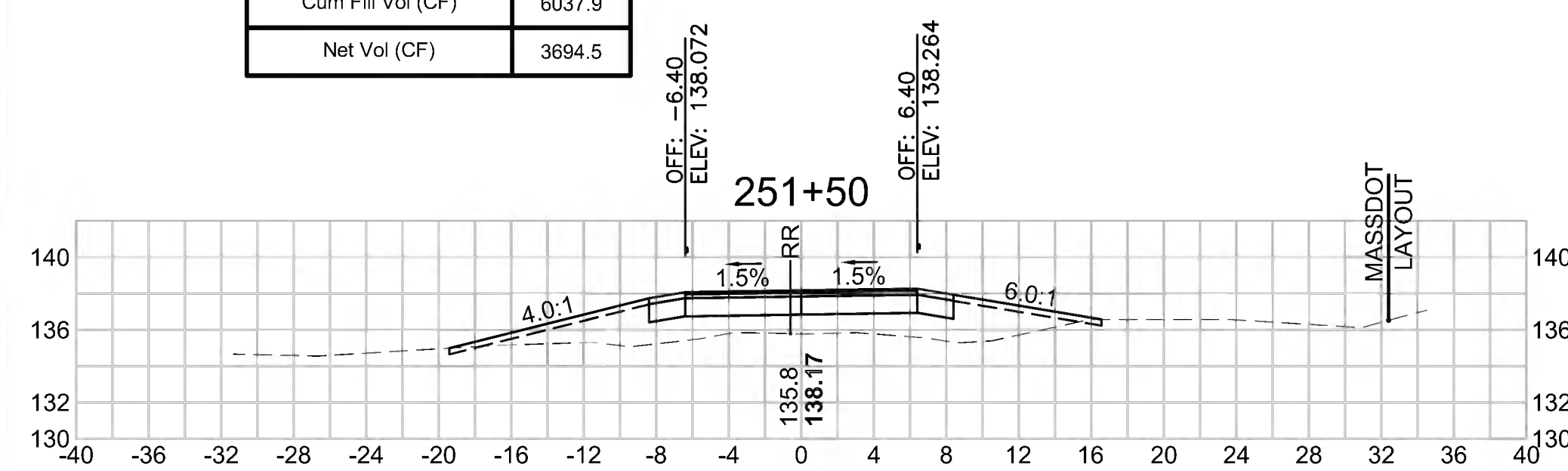

Total Volume at Station 253+00.00

Cut Area (SF)	0.259
Fill Area (SF)	72.794
Cut Vol (CF)	1.1
Fill Vol (CF)	117.8
Cum Cut Vol (CF)	9738.4
Cum Fill Vol (CF)	6324.6
Net Vol (CF)	3413.8

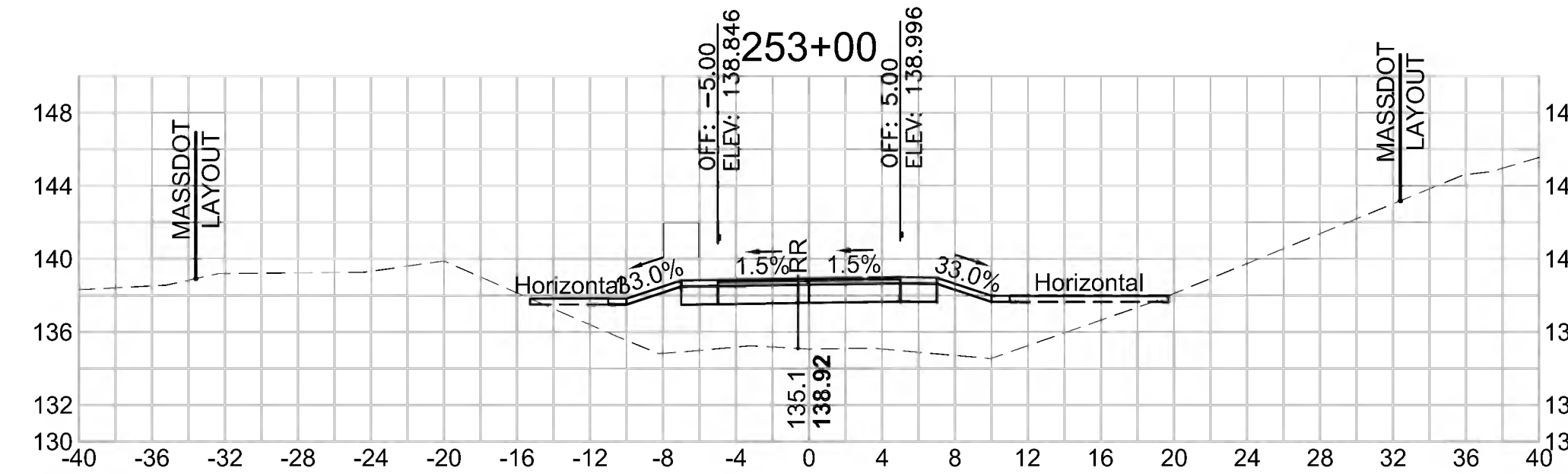

Total Volume at Station 254+50.00

Cut Area (SF)	0.182
Fill Area (SF)	118.086
Cut Vol (CF)	0.4
Fill Vol (CF)	204.0
Cum Cut Vol (CF)	9739.7
Cum Fill Vol (CF)	6845.5
Net Vol (CF)	2894.2

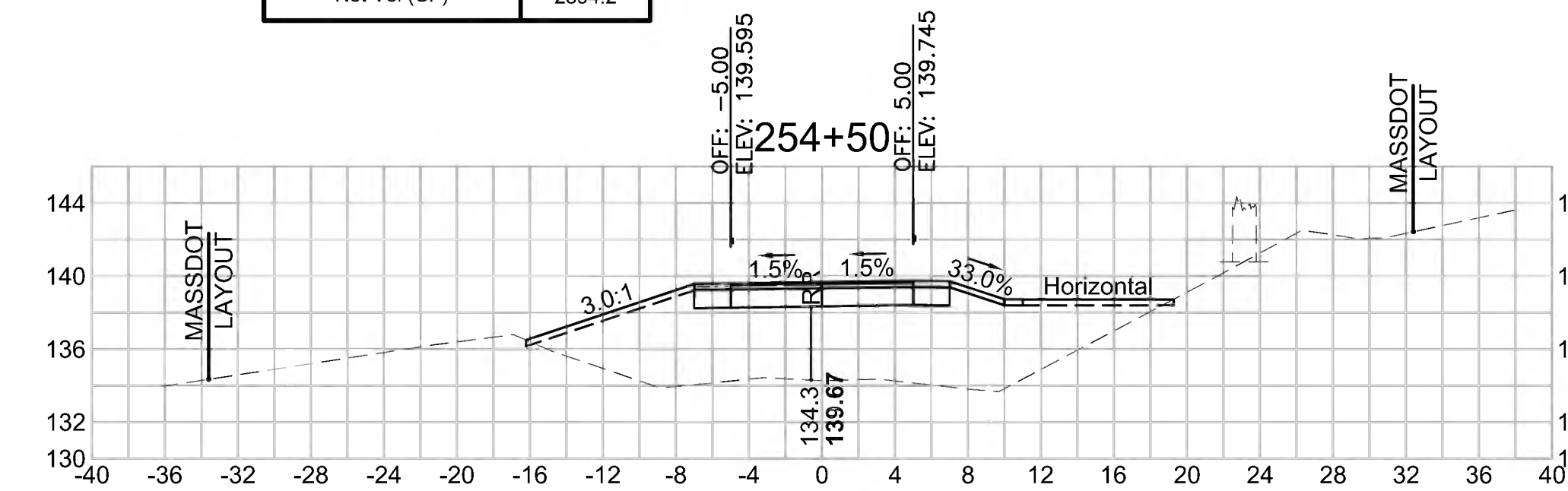

Total Volume at Station 251+00.00

Cut Area (SF)	1.399
Fill Area (SF)	35.563
Cut Vol (CF)	18.8
Fill Vol (CF)	39.9
Cum Cut Vol (CF)	9728.2
Cum Fill Vol (CF)	5970.1
Net Vol (CF)	3758.1

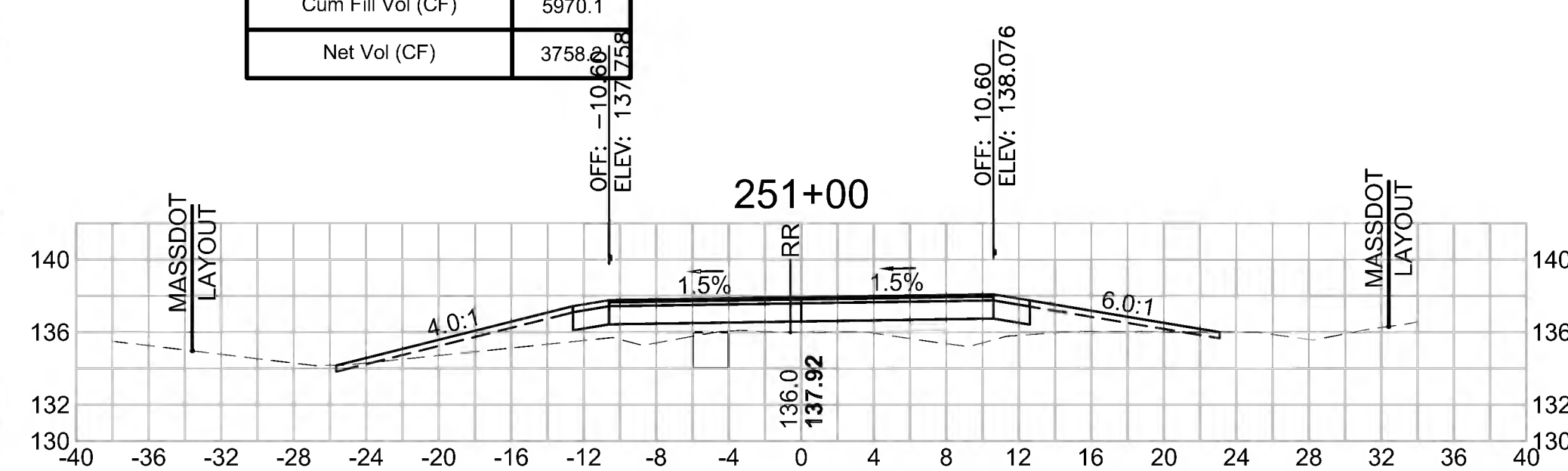

Total Volume at Station 252+50.00

Cut Area (SF)	0.898
Fill Area (SF)	54.414
Cut Vol (CF)	1.4
Fill Vol (CF)	92.2
Cum Cut Vol (CF)	9737.3
Cum Fill Vol (CF)	6206.8
Net Vol (CF)	3530.5

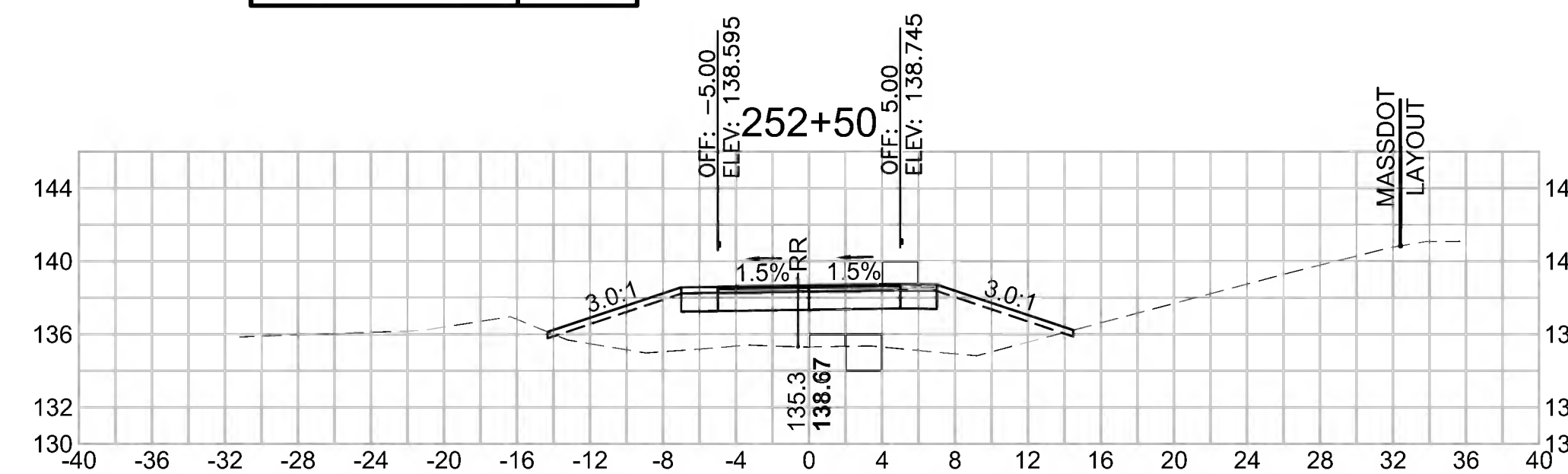

Total Volume at Station 254+00.00

Cut Area (SF)	0.232
Fill Area (SF)	102.202
Cut Vol (CF)	0.4
Fill Vol (CF)	172.1
Cum Cut Vol (CF)	9739.3
Cum Fill Vol (CF)	6641.5
Net Vol (CF)	3097.8

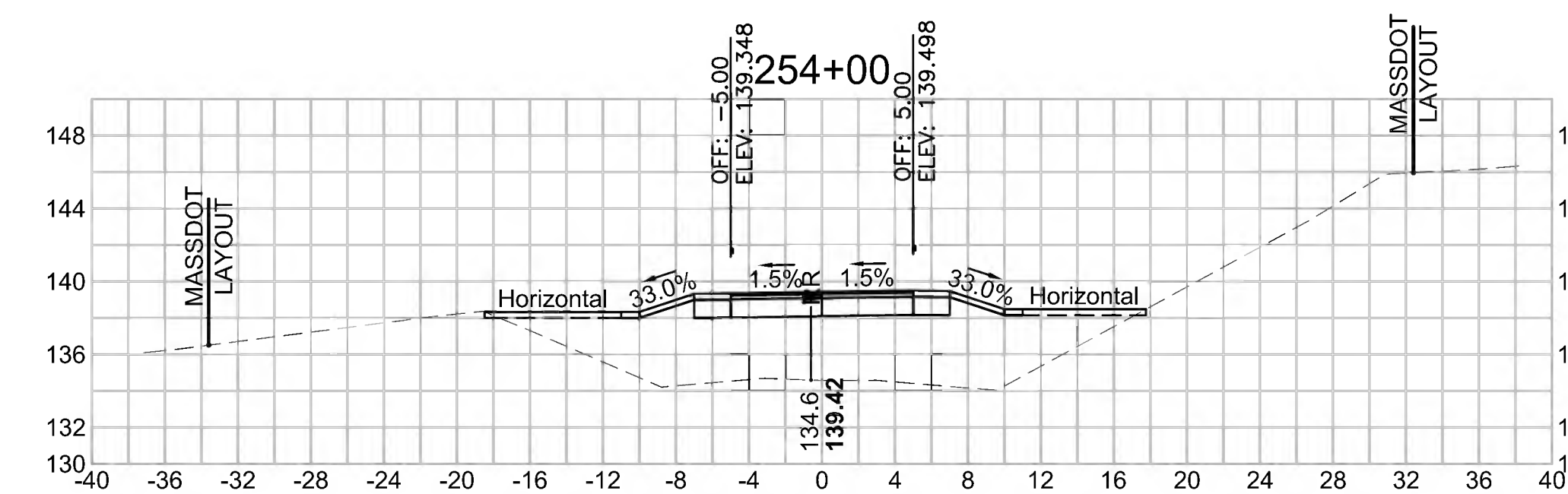

SUDBURY
BRUCE FREEMAN RAIL TRAIL

STATE	FED. AID PROJ. NO.	SHEET NO.	TOTAL SHEETS
MA	XXX-XXX(XXX)X	282	319

PROJECT FILE NO. 608164

CROSS SECTIONS

608164_XSEC(CROSS SECTION LAYOUTS).DWG 18-Feb-2022

Total Volume at Station 256+50.00	
Cut Area (SF)	0.588
Fill Area (SF)	72.871
Cut Vol (CF)	1.2
Fill Vol (CF)	152.0
Cum Cut Vol (CF)	9745.2
Cum Fill Vol (CF)	7613.7
Net Vol (CF)	2131.5

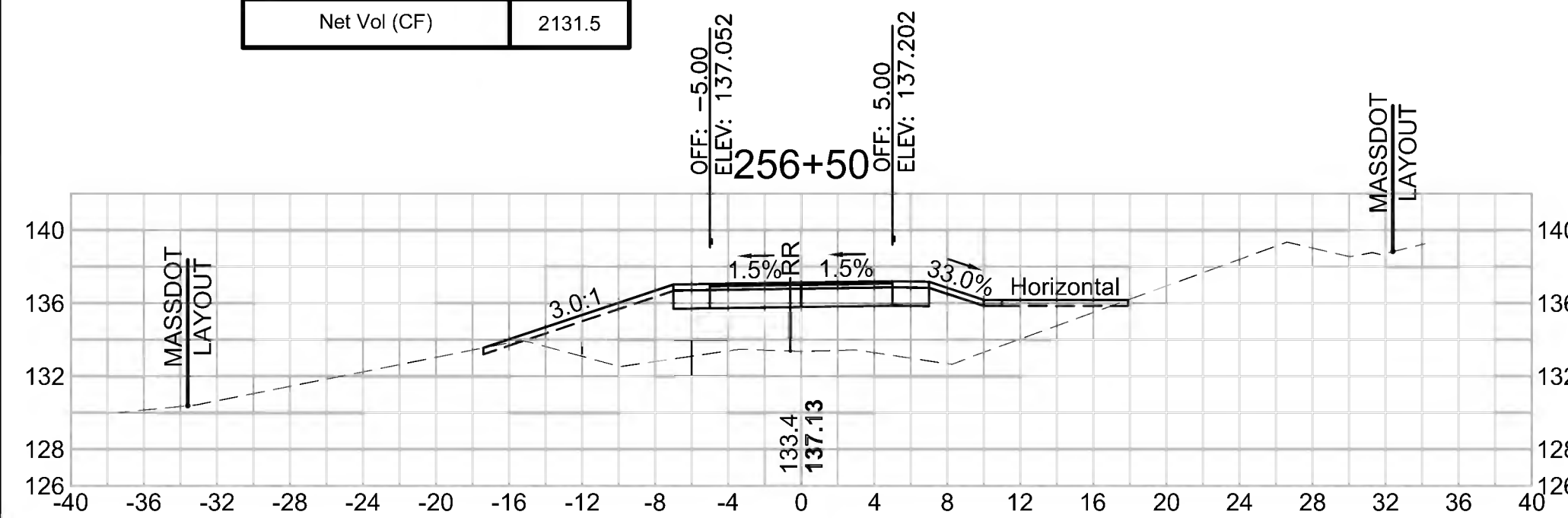

Total Volume at Station 258+00.00	
Cut Area (SF)	6.007
Fill Area (SF)	21.248
Cut Vol (CF)	11.3
Fill Vol (CF)	62.4
Cum Cut Vol (CF)	9763.2
Cum Fill Vol (CF)	7882.8
Net Vol (CF)	1880.4

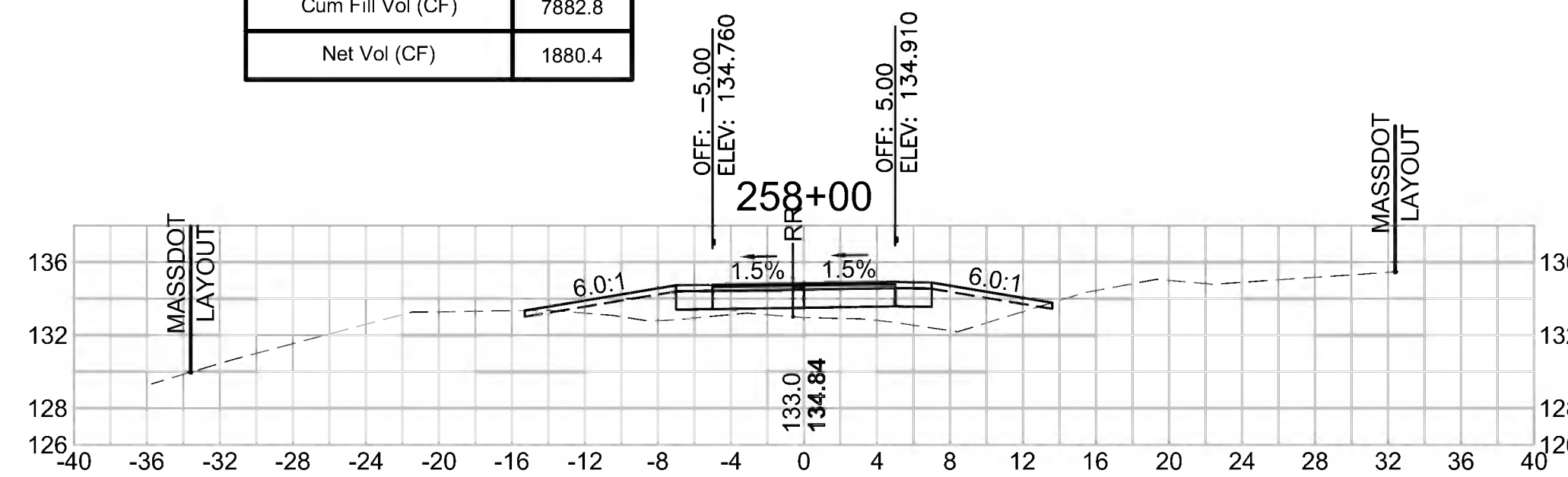

Total Volume at Station 259+50.00	
Cut Area (SF)	5.628
Fill Area (SF)	3.161
Cut Vol (CF)	12.0
Fill Vol (CF)	7.4
Cum Cut Vol (CF)	9794.4
Cum Fill Vol (CF)	7923.5
Net Vol (CF)	1870.9

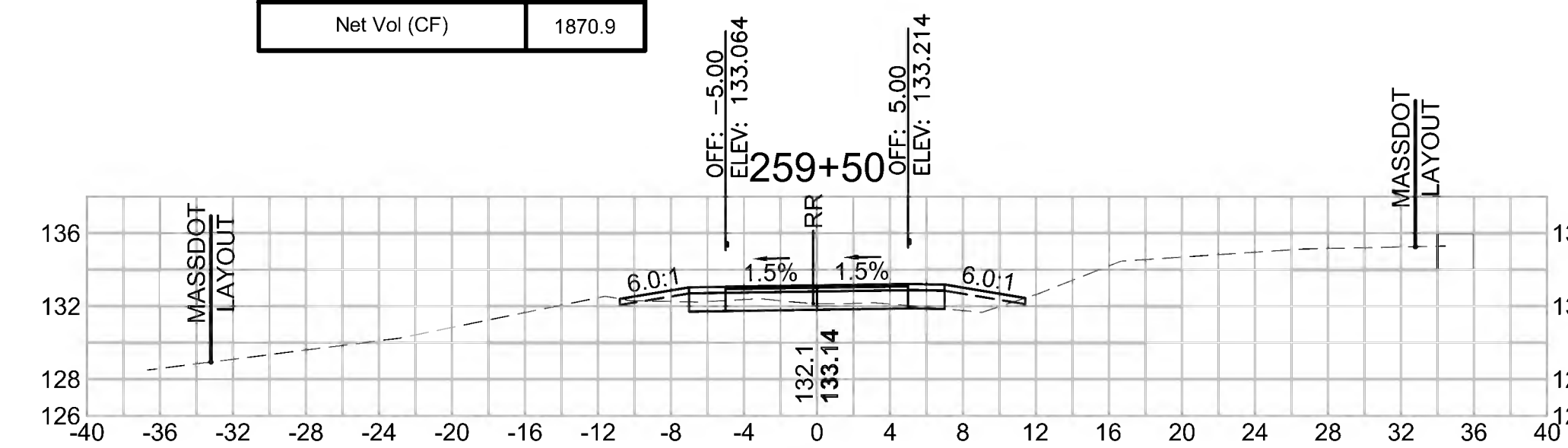

Total Volume at Station 256+00.00	
Cut Area (SF)	0.663
Fill Area (SF)	91.311
Cut Vol (CF)	1.6
Fill Vol (CF)	185.4
Cum Cut Vol (CF)	9744.0
Cum Fill Vol (CF)	7461.6
Net Vol (CF)	2282.4

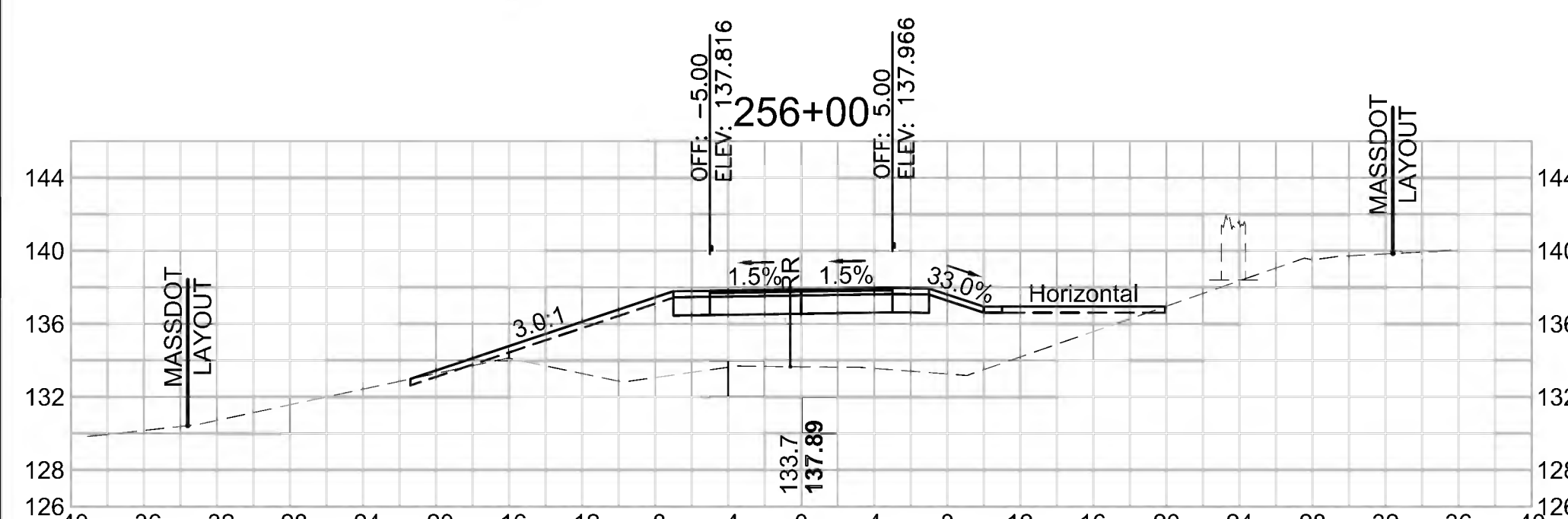

Total Volume at Station 257+50.00	
Cut Area (SF)	6.216
Fill Area (SF)	46.159
Cut Vol (CF)	6.0
Fill Vol (CF)	91.0
Cum Cut Vol (CF)	9751.9
Cum Fill Vol (CF)	7820.4
Net Vol (CF)	1931.5

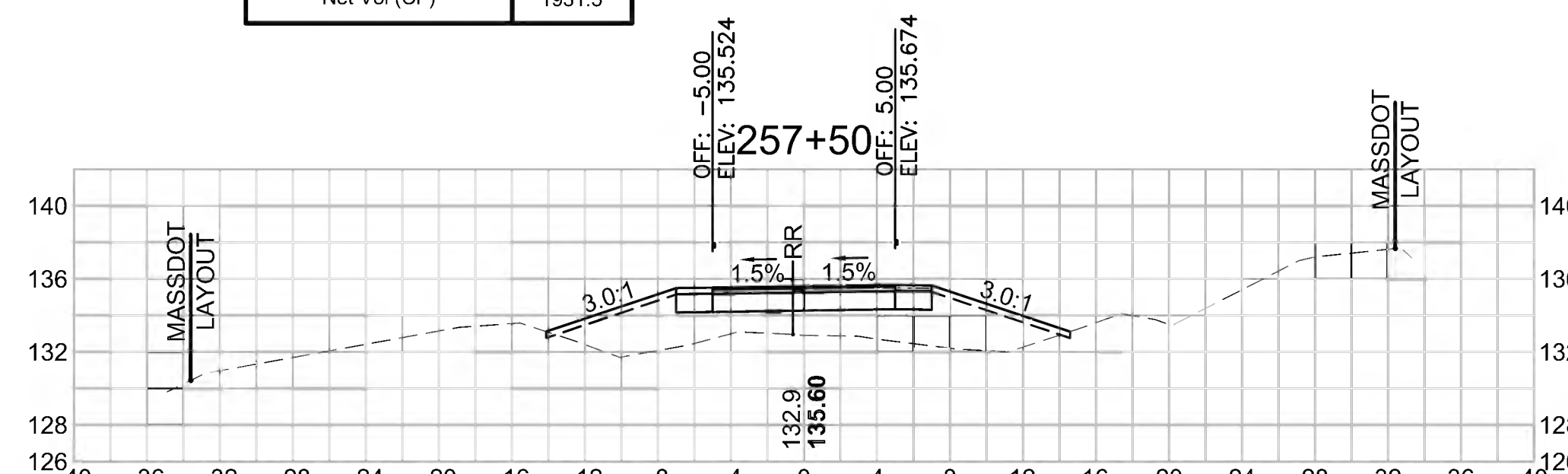

Total Volume at Station 259+00.00	
Cut Area (SF)	7.382
Fill Area (SF)	4.819
Cut Vol (CF)	10.2
Fill Vol (CF)	9.1
Cum Cut Vol (CF)	9782.4
Cum Fill Vol (CF)	7916.2
Net Vol (CF)	1866.2

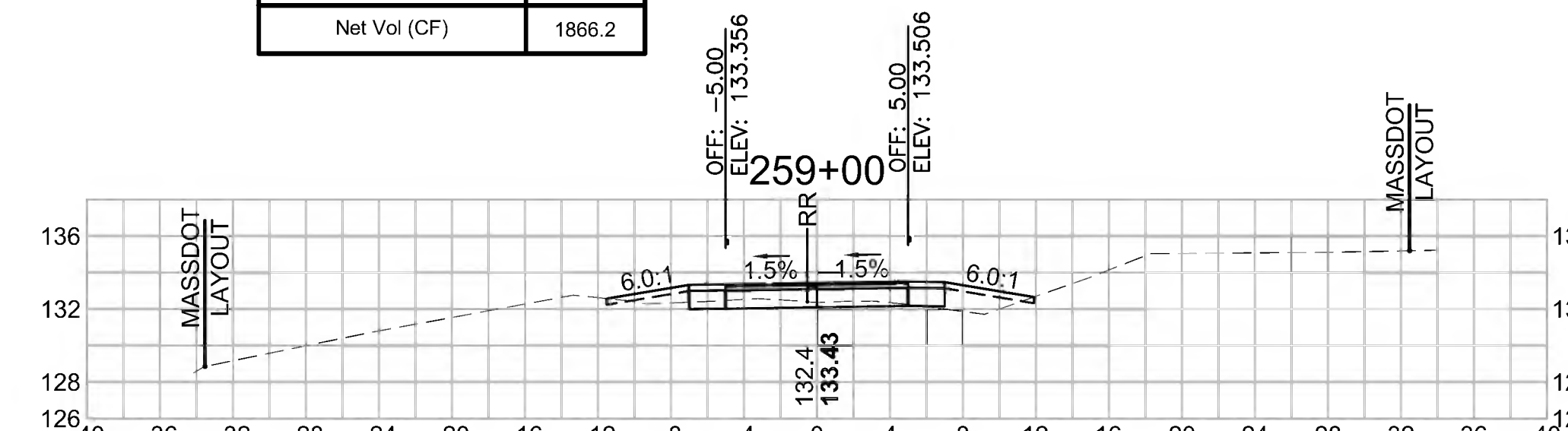

Total Volume at Station 255+50.00	
Cut Area (SF)	1.054
Fill Area (SF)	108.950
Cut Vol (CF)	1.8
Fill Vol (CF)	211.1
Cum Cut Vol (CF)	9742.4
Cum Fill Vol (CF)	7276.2
Net Vol (CF)	2466.2

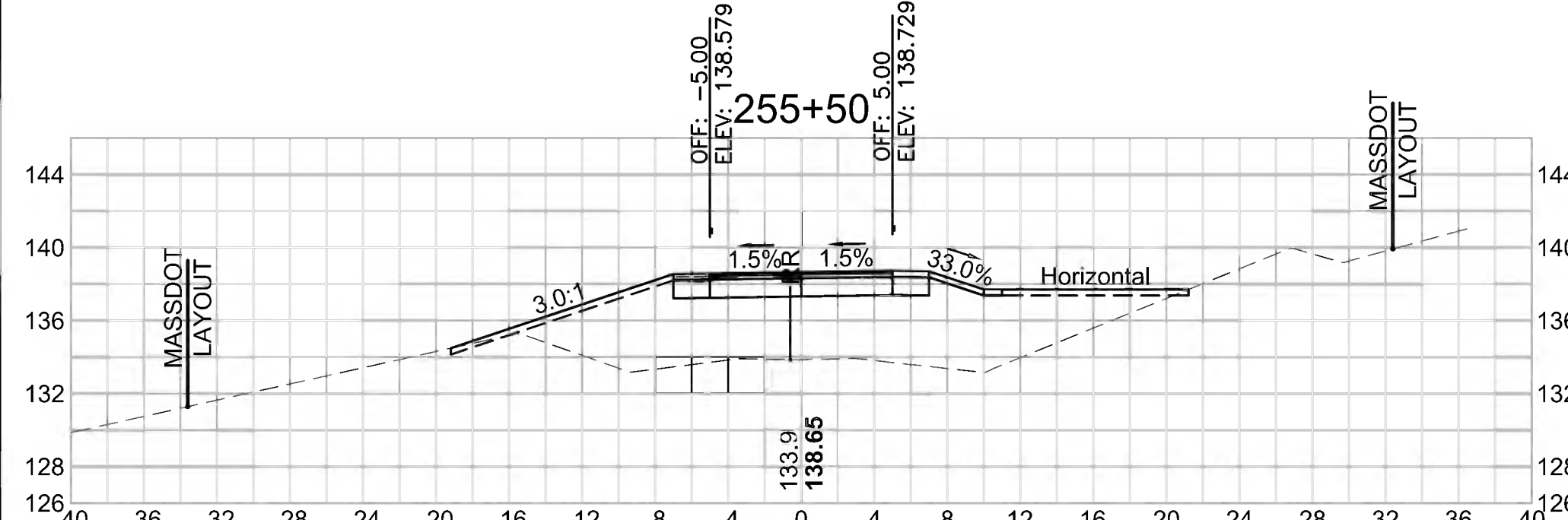

Total Volume at Station 257+00.00	
Cut Area (SF)	0.231
Fill Area (SF)	52.096
Cut Vol (CF)	0.8
Fill Vol (CF)	115.7
Cum Cut Vol (CF)	9745.9
Cum Fill Vol (CF)	7729.4
Net Vol (CF)	2016.5

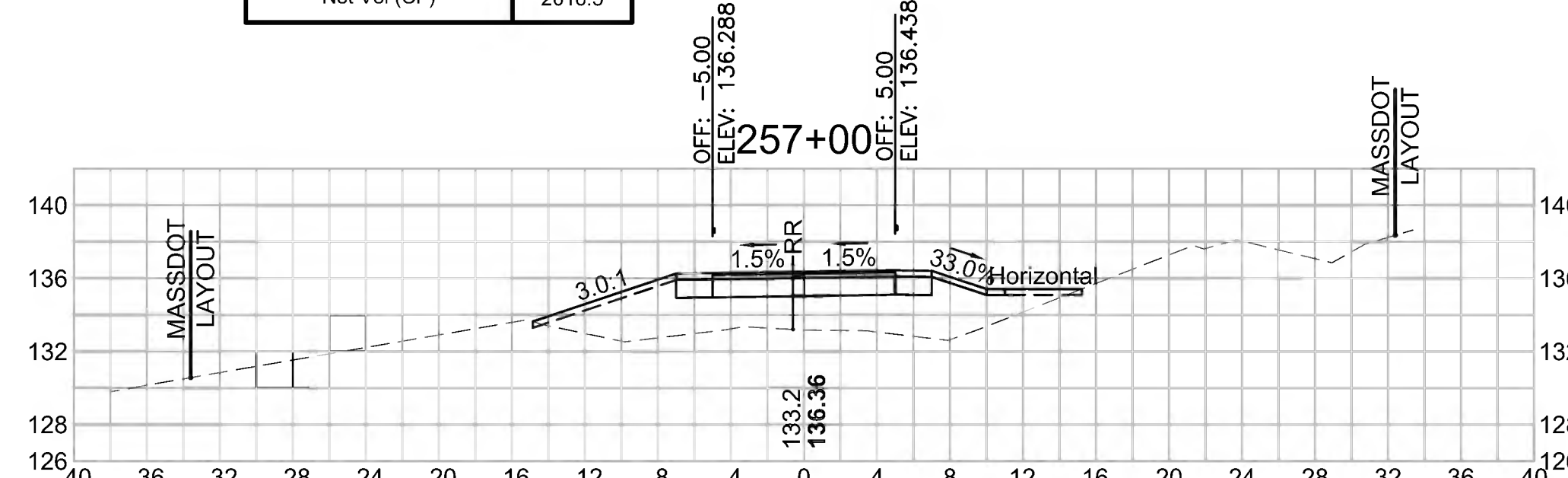

Total Volume at Station 258+50.00	
Cut Area (SF)	3.667
Fill Area (SF)	4.995
Cut Vol (CF)	9.0
Fill Vol (CF)	24.3
Cum Cut Vol (CF)	9772.2
Cum Fill Vol (CF)	7907.1
Net Vol (CF)	1865.1

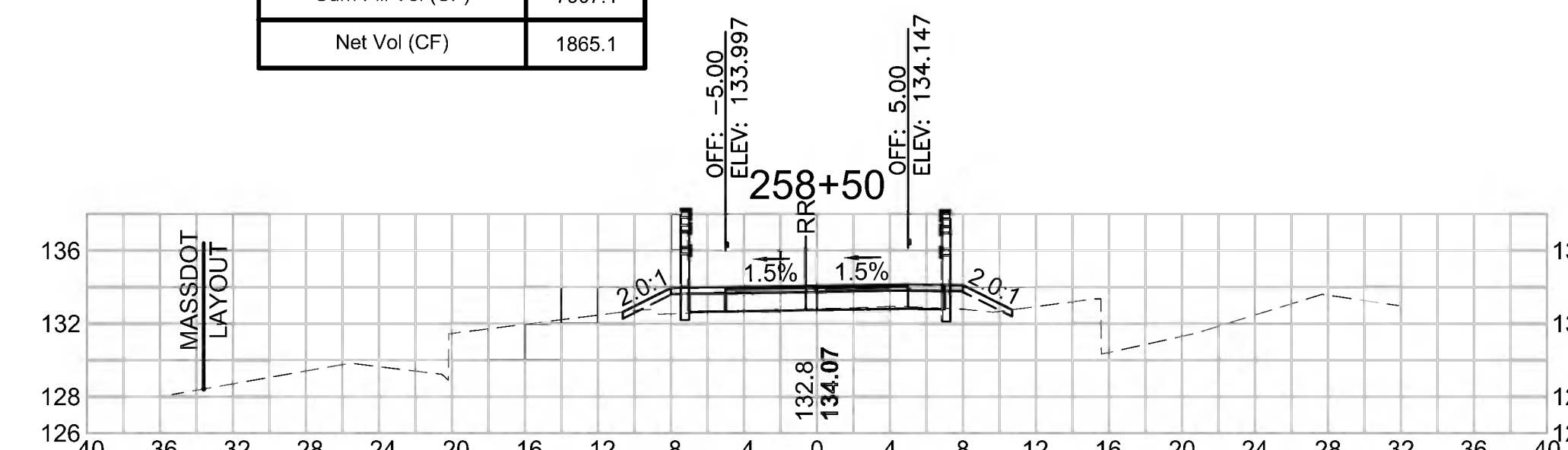

SUDBURY
BRUCE FREEMAN RAIL TRAIL

STATE	FED. AID PROJ. NO.	SHEET NO.	TOTAL SHEETS
MA	XXX-XXXX(XXX)X	283	319

PROJECT FILE NO. 608164

CROSS SECTIONS

18-Feb-2022
608164_XSEC(CROSS SECTION LAYOUTS).DWG

Total Volume at Station 261+00.00	
Cut Area (SF)	6.614
Fill Area (SF)	10.801
Cut Vol (CF)	11.9
Fill Vol (CF)	16.6
Cum Cut Vol (CF)	9831.5
Cum Fill Vol (CF)	7955.7
Net Vol (CF)	1875.8

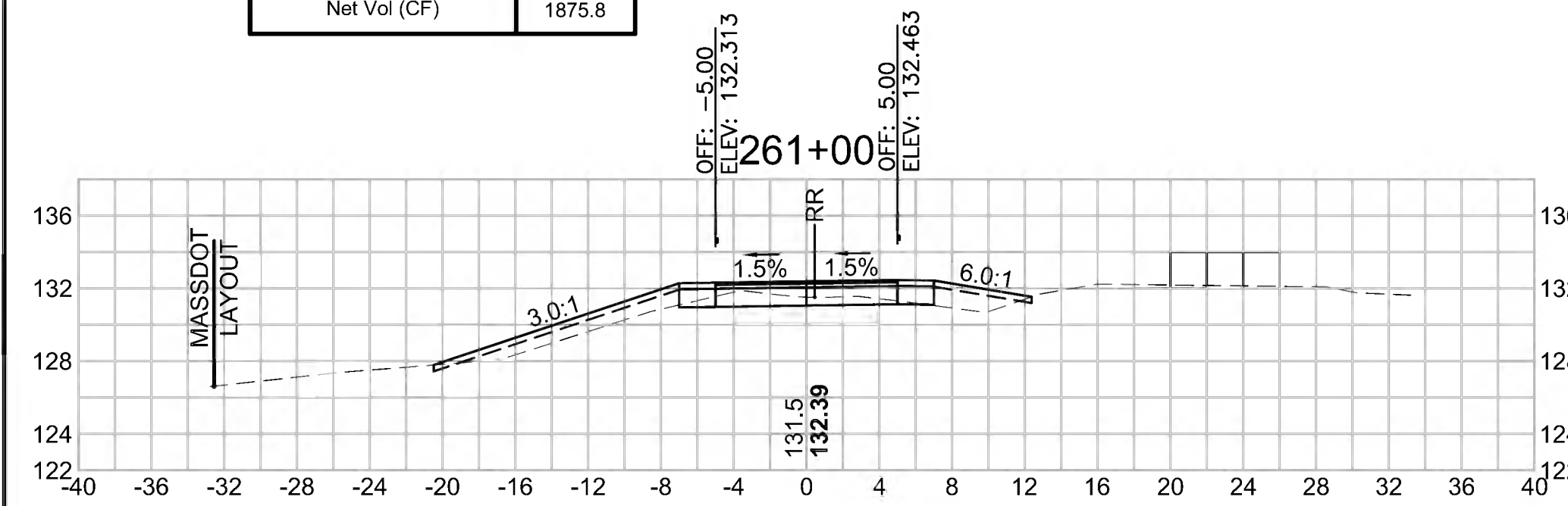

Total Volume at Station 262+50.00	
Cut Area (SF)	34.753
Fill Area (SF)	0.000
Cut Vol (CF)	53.7
Fill Vol (CF)	0.9
Cum Cut Vol (CF)	9936.3
Cum Fill Vol (CF)	7979.2
Net Vol (CF)	1957.0

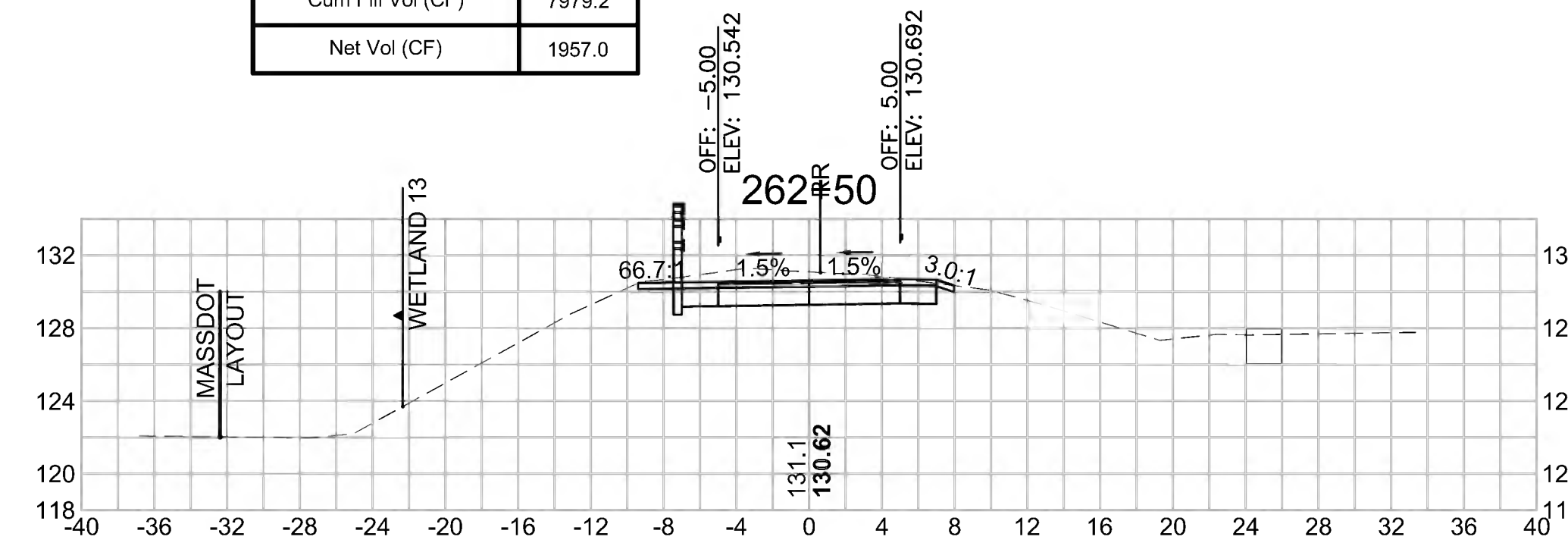

Total Volume at Station 264+00.00	
Cut Area (SF)	44.515
Fill Area (SF)	2.235
Cut Vol (CF)	77.6
Fill Vol (CF)	2.1
Cum Cut Vol (CF)	10147.2
Cum Fill Vol (CF)	7981.4
Net Vol (CF)	2165.8

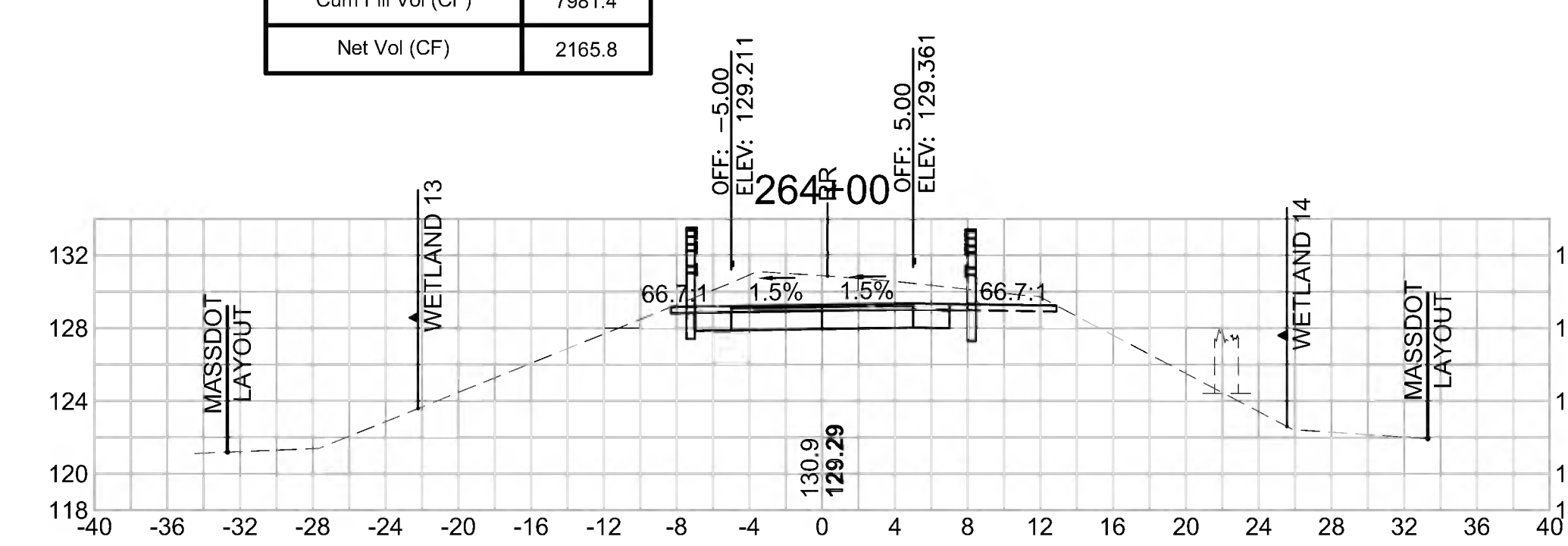

Total Volume at Station 260+50.00	
Cut Area (SF)	6.241
Fill Area (SF)	7.127
Cut Vol (CF)	12.8
Fill Vol (CF)	9.6
Cum Cut Vol (CF)	9819.6
Cum Fill Vol (CF)	7939.1
Net Vol (CF)	1880.5

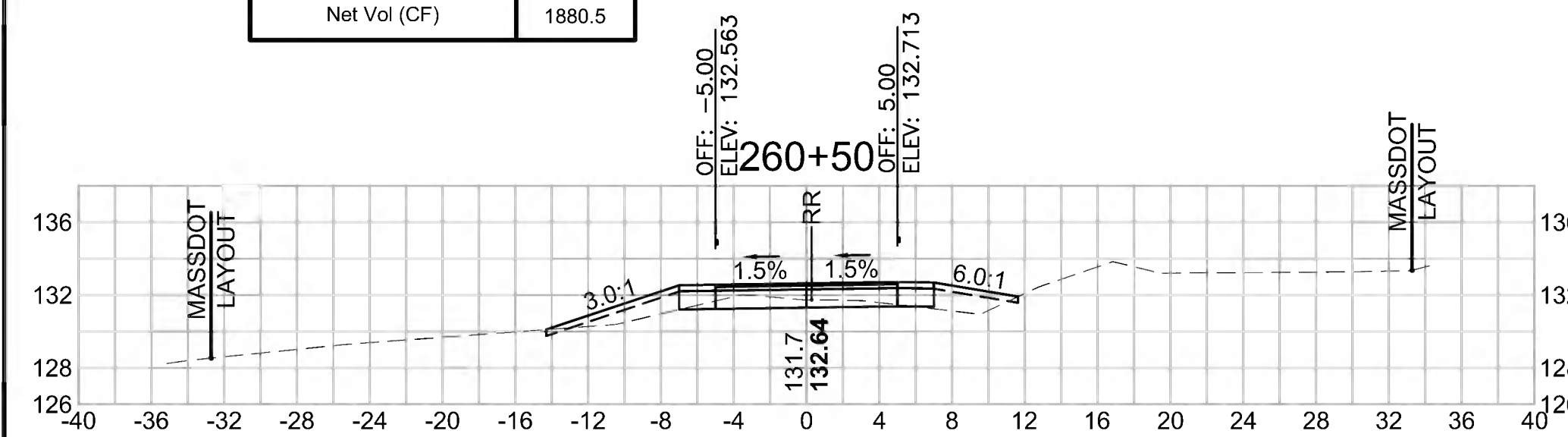

Total Volume at Station 262+00.00	
Cut Area (SF)	23.243
Fill Area (SF)	0.932
Cut Vol (CF)	33.3
Fill Vol (CF)	6.8
Cum Cut Vol (CF)	9882.6
Cum Fill Vol (CF)	7978.4
Net Vol (CF)	1904.2

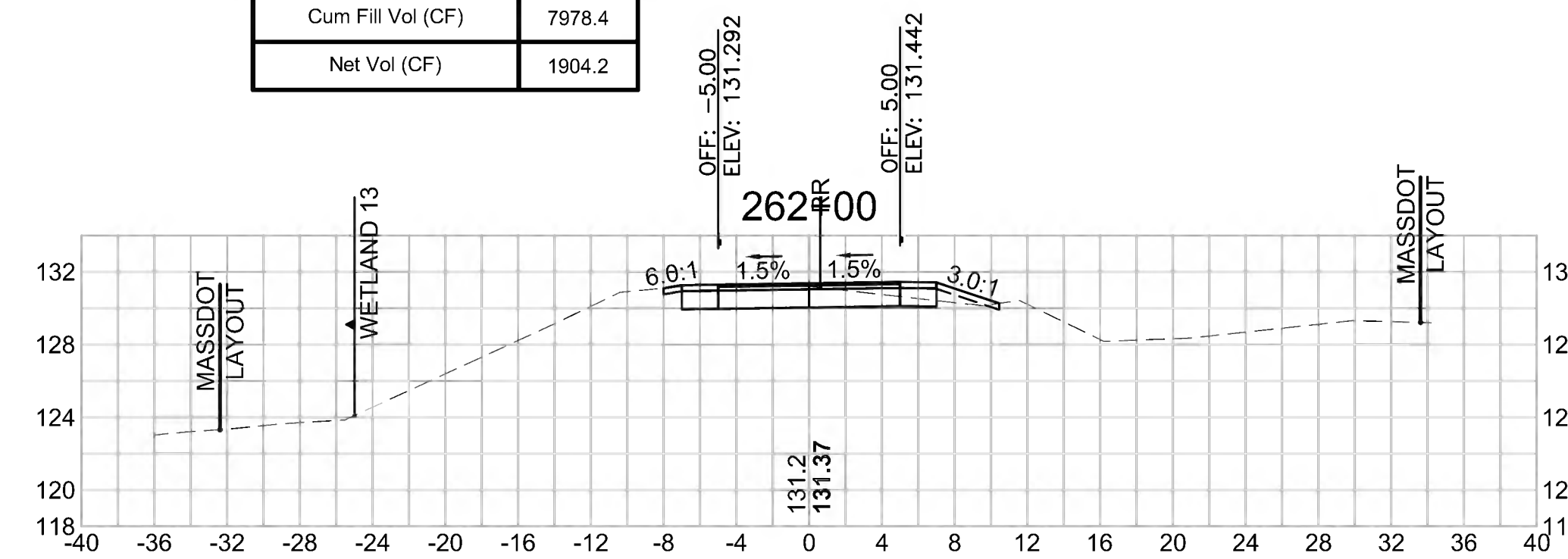

Total Volume at Station 263+50.00	
Cut Area (SF)	39.330
Fill Area (SF)	0.000
Cut Vol (CF)	68.8
Fill Vol (CF)	0.1
Cum Cut Vol (CF)	10069.6
Cum Fill Vol (CF)	7979.4
Net Vol (CF)	2090.3

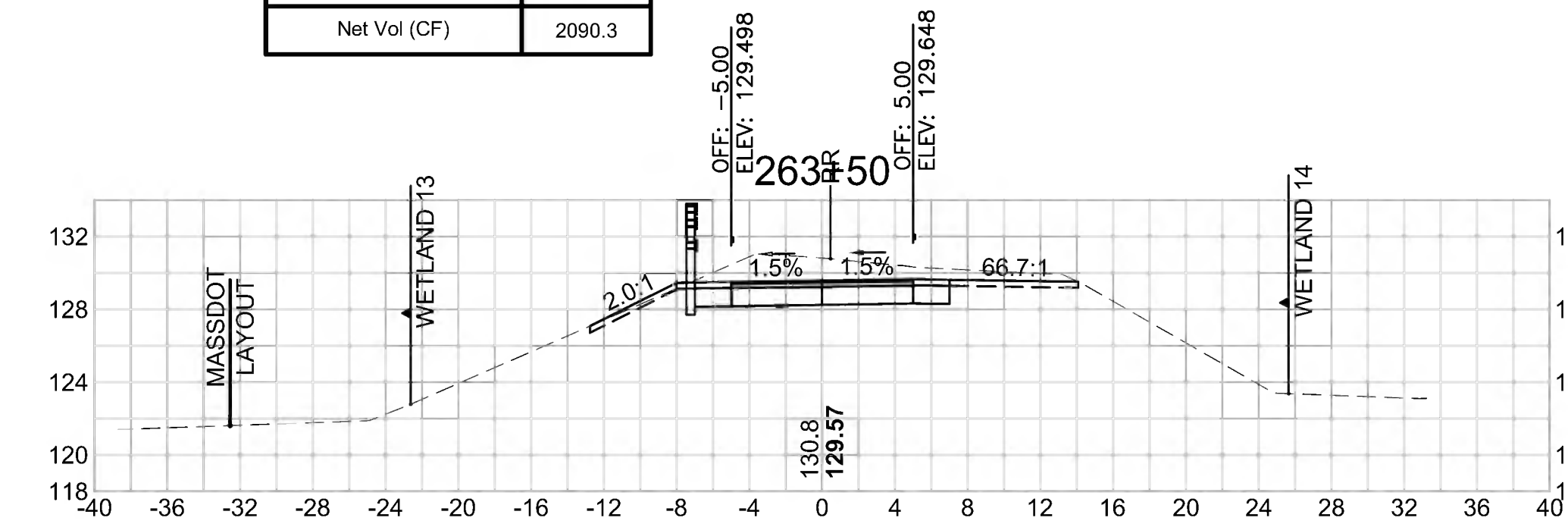

Total Volume at Station 260+00.00	
Cut Area (SF)	7.630
Fill Area (SF)	3.238
Cut Vol (CF)	12.3
Fill Vol (CF)	5.9
Cum Cut Vol (CF)	9806.7
Cum Fill Vol (CF)	7929.5
Net Vol (CF)	1877.3

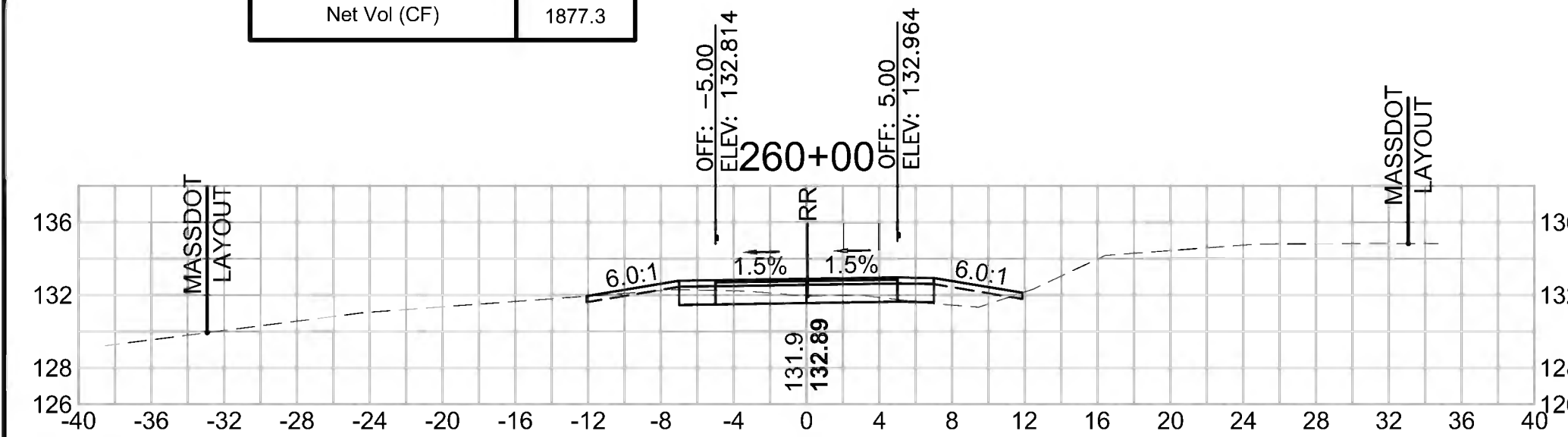

Total Volume at Station 261+50.00	
Cut Area (SF)	12.670
Fill Area (SF)	6.395
Cut Vol (CF)	17.9
Fill Vol (CF)	15.9
Cum Cut Vol (CF)	9849.3
Cum Fill Vol (CF)	7971.6
Net Vol (CF)	1877.7

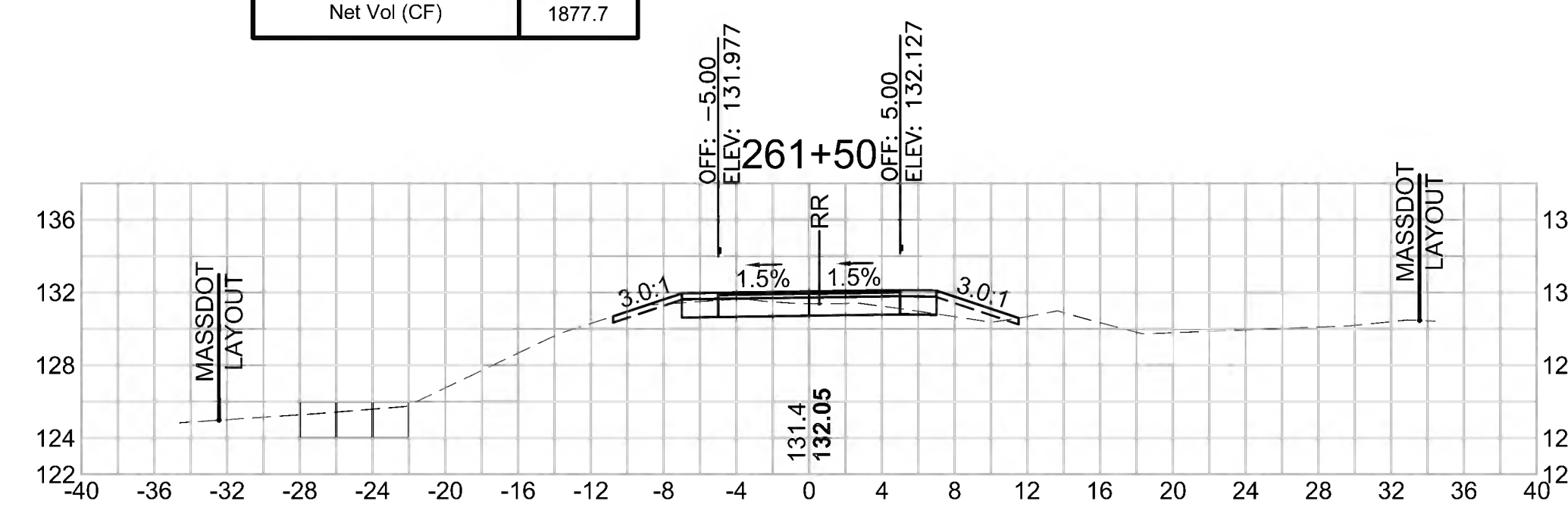

Total Volume at Station 263+00.00	
Cut Area (SF)	34.961
Fill Area (SF)	0.066
Cut Vol (CF)	64.5
Fill Vol (CF)	0.1
Cum Cut Vol (CF)	10000.8
Cum Fill Vol (CF)	7979.3
Net Vol (CF)	2021.5

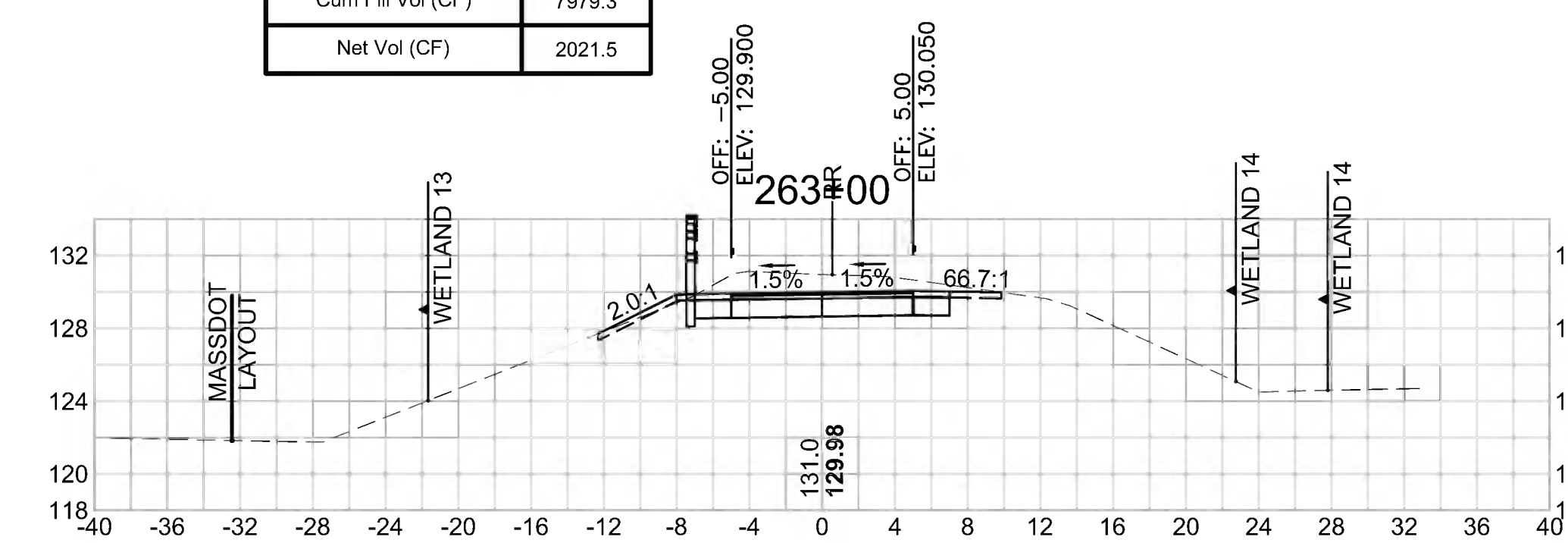

SUDBURY
BRUCE FREEMAN RAIL TRAIL

STATE	FED. AID PROJ. NO.	SHEET NO.	TOTAL SHEETS
MA	XXX-XXXX(XXX)X	284	319

PROJECT FILE NO. 608164

CROSS SECTIONS

608164_XSEC(CROSS SECTION LAYOUTS).DWG 18-Feb-2022

Total Volume at Station 265+50.00	
Cut Area (SF)	28.952
Fill Area (SF)	0.000
Cut Vol (CF)	61.6
Fill Vol (CF)	0.0
Cum Cut Vol (CF)	10369.1
Cum Fill Vol (CF)	7984.9
Net Vol (CF)	2384.2

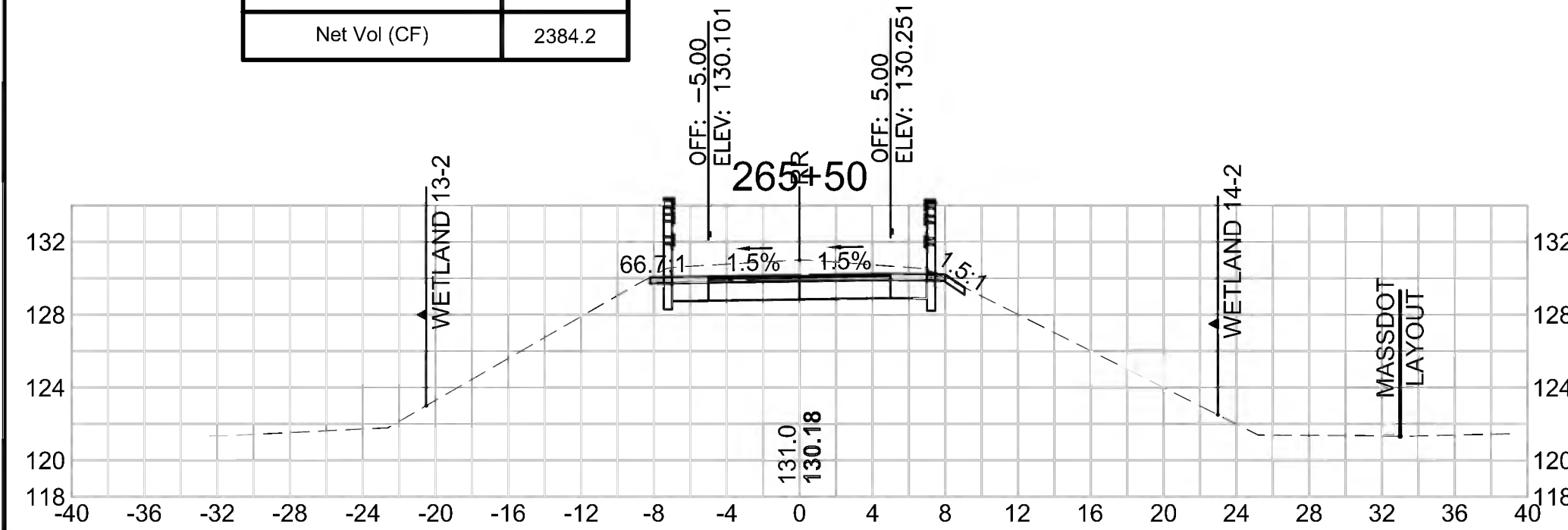

Total Volume at Station 267+00.00	
Cut Area (SF)	9.594
Fill Area (SF)	3.254
Cut Vol (CF)	28.3
Fill Vol (CF)	4.9
Cum Cut Vol (CF)	10486.7
Cum Fill Vol (CF)	7991.7
Net Vol (CF)	2495.0

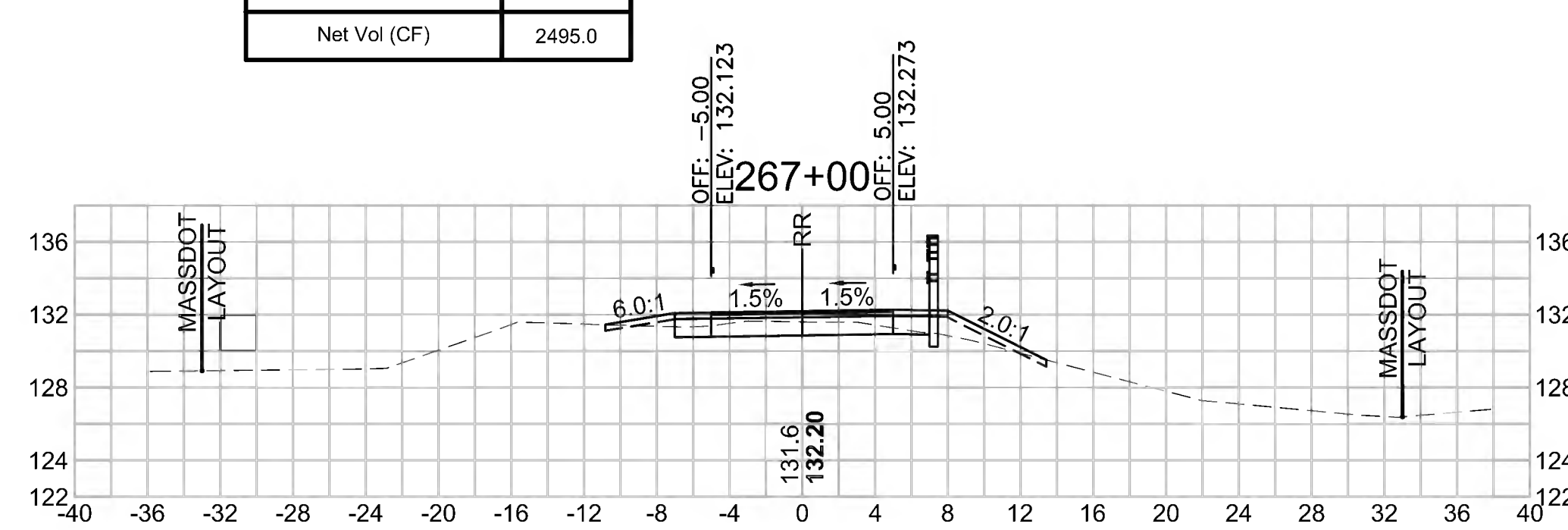

Total Volume at Station 268+50.00	
Cut Area (SF)	6.922
Fill Area (SF)	5.881
Cut Vol (CF)	14.0
Fill Vol (CF)	8.7
Cum Cut Vol (CF)	10532.1
Cum Fill Vol (CF)	8014.2
Net Vol (CF)	2517.9

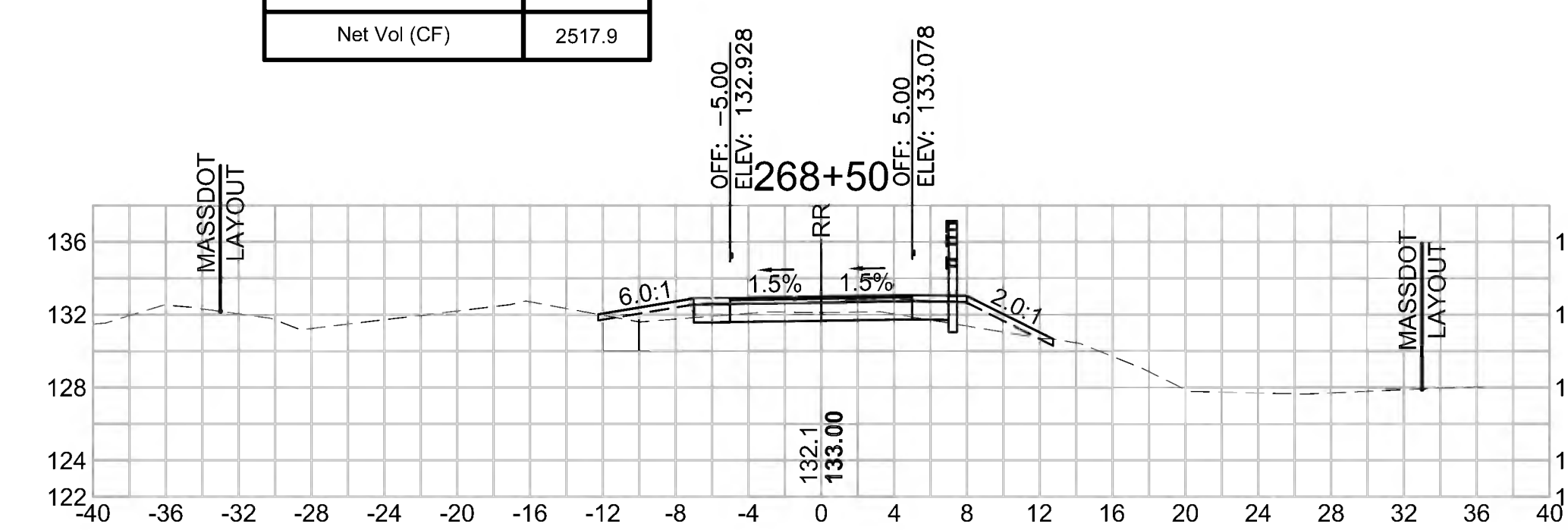

Total Volume at Station 265+00.00	
Cut Area (SF)	37.581
Fill Area (SF)	0.000
Cut Vol (CF)	76.9
Fill Vol (CF)	0.7
Cum Cut Vol (CF)	10307.5
Cum Fill Vol (CF)	7984.9
Net Vol (CF)	2322.6

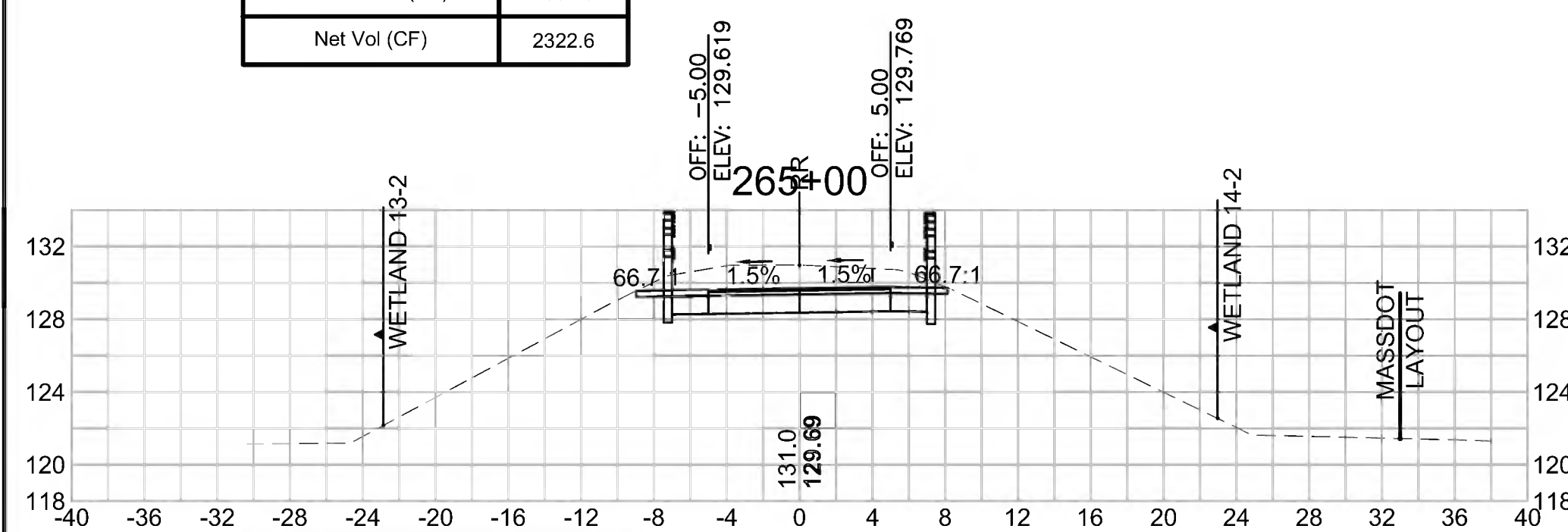

Total Volume at Station 266+50.00	
Cut Area (SF)	20.963
Fill Area (SF)	2.079
Cut Vol (CF)	41.0
Fill Vol (CF)	1.9
Cum Cut Vol (CF)	10458.4
Cum Fill Vol (CF)	7986.8
Net Vol (CF)	2471.6

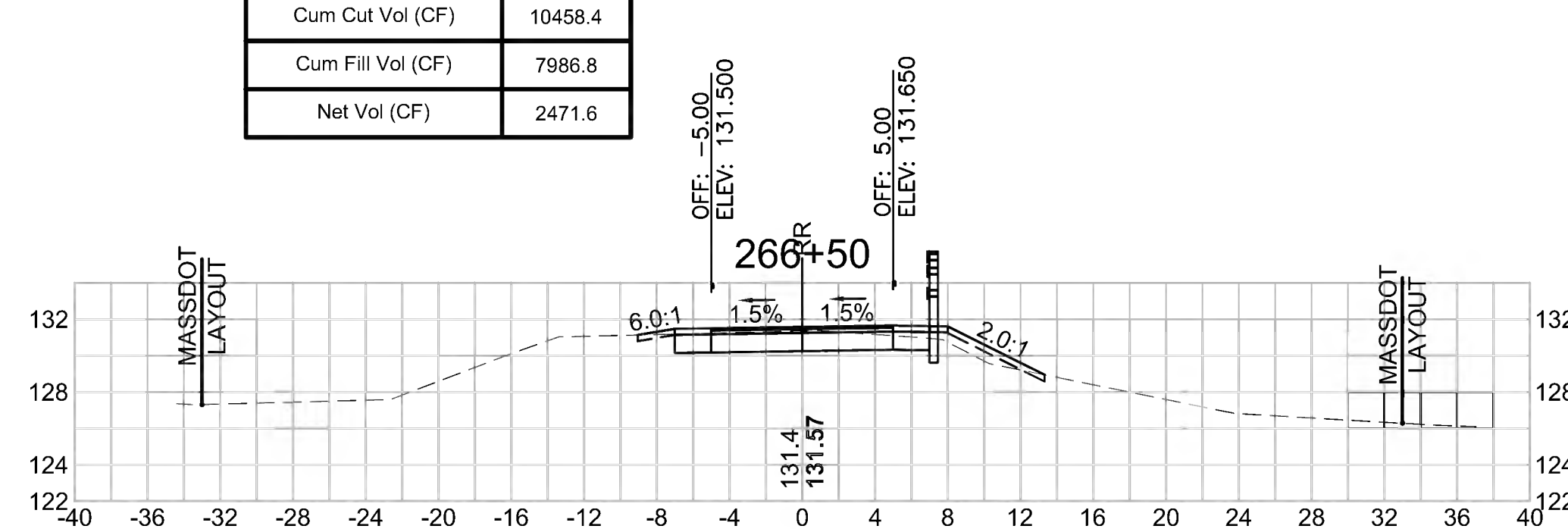

Total Volume at Station 268+00.00	
Cut Area (SF)	8.250
Fill Area (SF)	3.461
Cut Vol (CF)	15.0
Fill Vol (CF)	7.0
Cum Cut Vol (CF)	10518.0
Cum Fill Vol (CF)	8005.6
Net Vol (CF)	2512.5

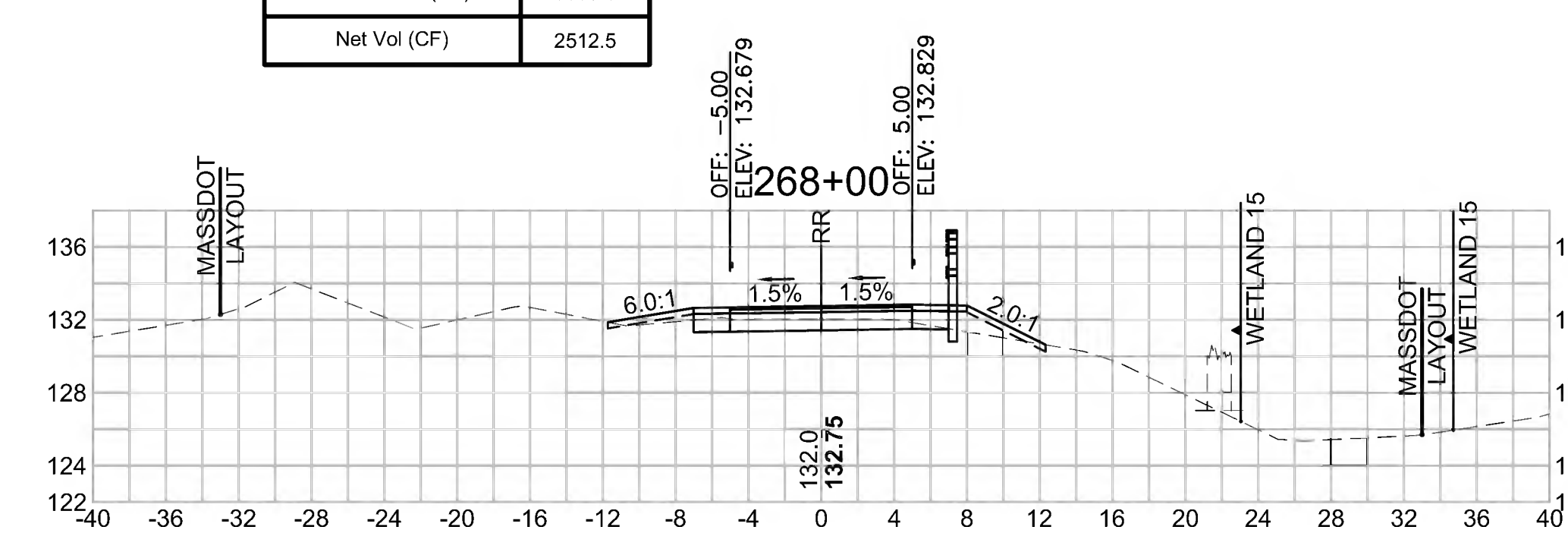

Total Volume at Station 264+50.00	
Cut Area (SF)	45.493
Fill Area (SF)	0.745
Cut Vol (CF)	83.3
Fill Vol (CF)	2.8
Cum Cut Vol (CF)	10230.6
Cum Fill Vol (CF)	7984.2
Net Vol (CF)	2246.4

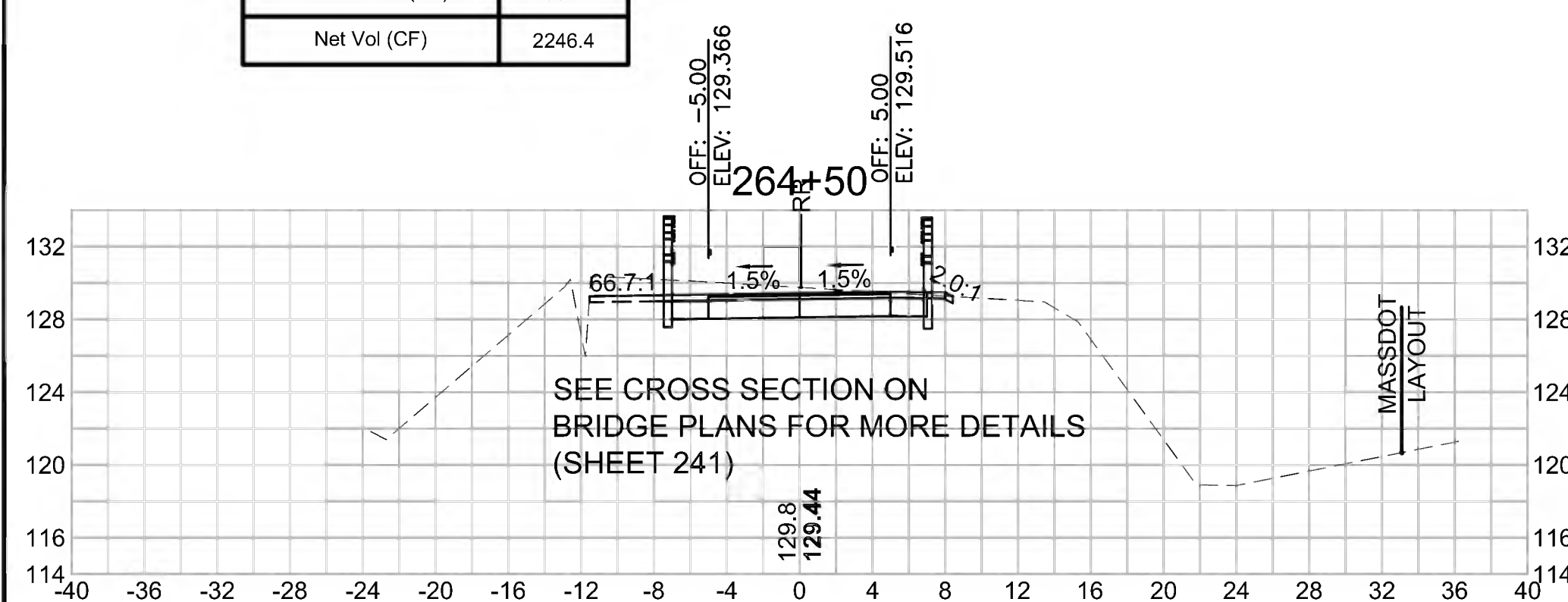

Total Volume at Station 266+00.00	
Cut Area (SF)	23.271
Fill Area (SF)	0.000
Cut Vol (CF)	48.4
Fill Vol (CF)	0.0
Cum Cut Vol (CF)	10417.5
Cum Fill Vol (CF)	7984.9
Net Vol (CF)	2432.6

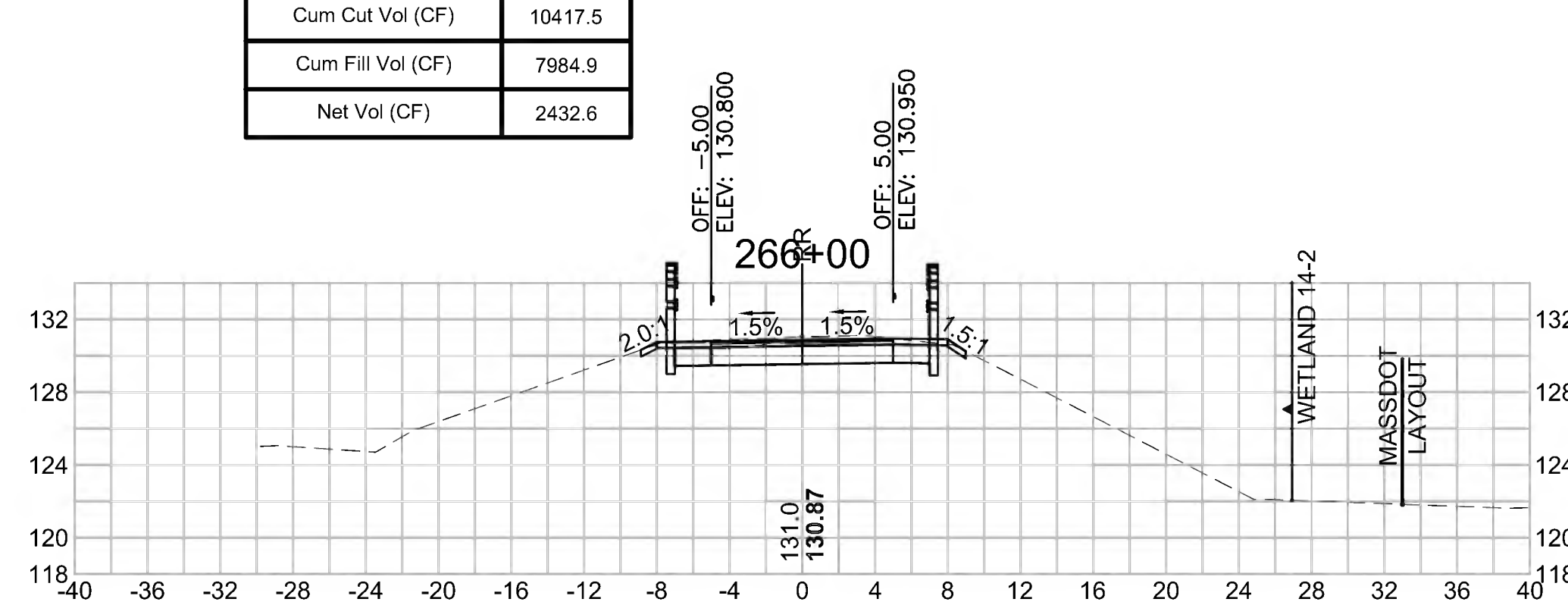

Total Volume at Station 267+50.00	
Cut Area (SF)	7.984
Fill Area (SF)	4.106
Cut Vol (CF)	16.3
Fill Vol (CF)	6.8
Cum Cut Vol (CF)	10503.0
Cum Fill Vol (CF)	7998.5
Net Vol (CF)	2504.4

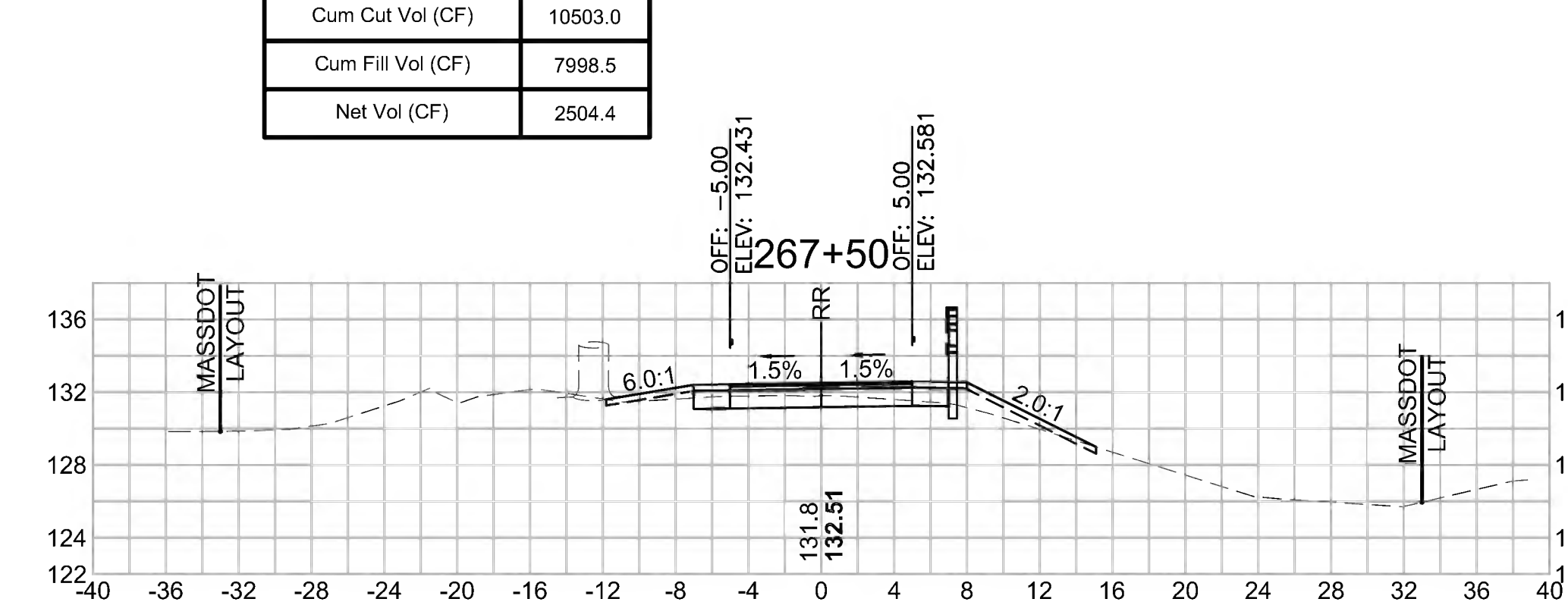

SUDBURY
BRUCE FREEMAN RAIL TRAIL

STATE	FED. AID PROJ. NO.	SHEET NO.	TOTAL SHEETS
MA	XXX-XXXX(XXX)X	285	319

PROJECT FILE NO. 608164

CROSS SECTIONS

Total Volume at Station 270+00.00

Cut Area (SF)	16.801
Fill Area (SF)	5.138
Cut Vol (CF)	26.2
Fill Vol (CF)	14.4
Cum Cut Vol (CF)	10586.1
Cum Fill Vol (CF)	8064.4
Net Vol (CF)	2521.6

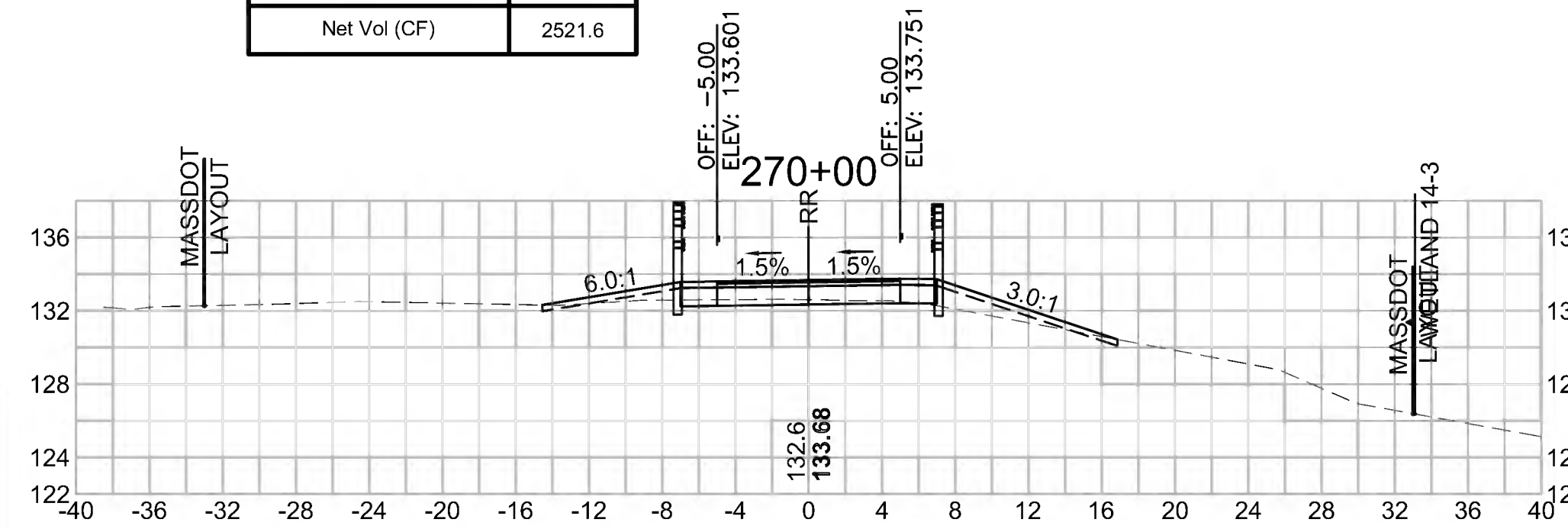

Total Volume at Station 271+50.00

Cut Area (SF)	15.888
Fill Area (SF)	3.101
Cut Vol (CF)	19.2
Fill Vol (CF)	10.0
Cum Cut Vol (CF)	10639.5
Cum Fill Vol (CF)	8095.3
Net Vol (CF)	2544.2

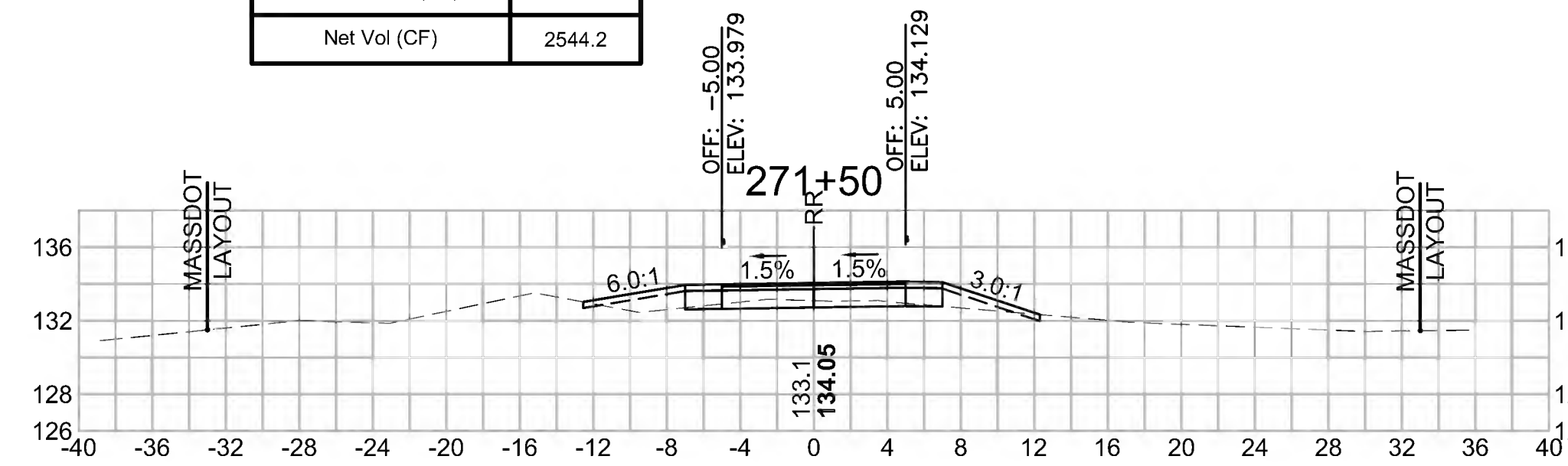

Total Volume at Station 273+00.00

Cut Area (SF)	8.276
Fill Area (SF)	3.215
Cut Vol (CF)	16.3
Fill Vol (CF)	8.6
Cum Cut Vol (CF)	10717.0
Cum Fill Vol (CF)	8119.4
Net Vol (CF)	2597.7

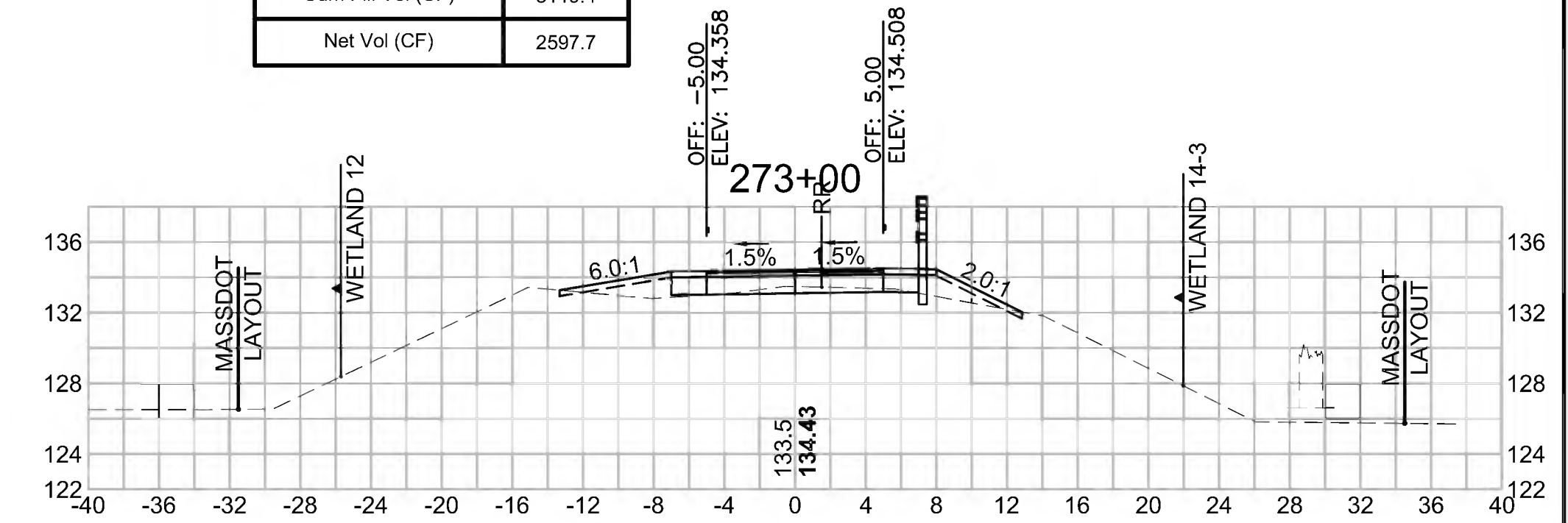

Total Volume at Station 269+50.00

Cut Area (SF)	11.450
Fill Area (SF)	10.431
Cut Vol (CF)	16.0
Fill Vol (CF)	20.0
Cum Cut Vol (CF)	10559.9
Cum Fill Vol (CF)	8050.0
Net Vol (CF)	2509.9

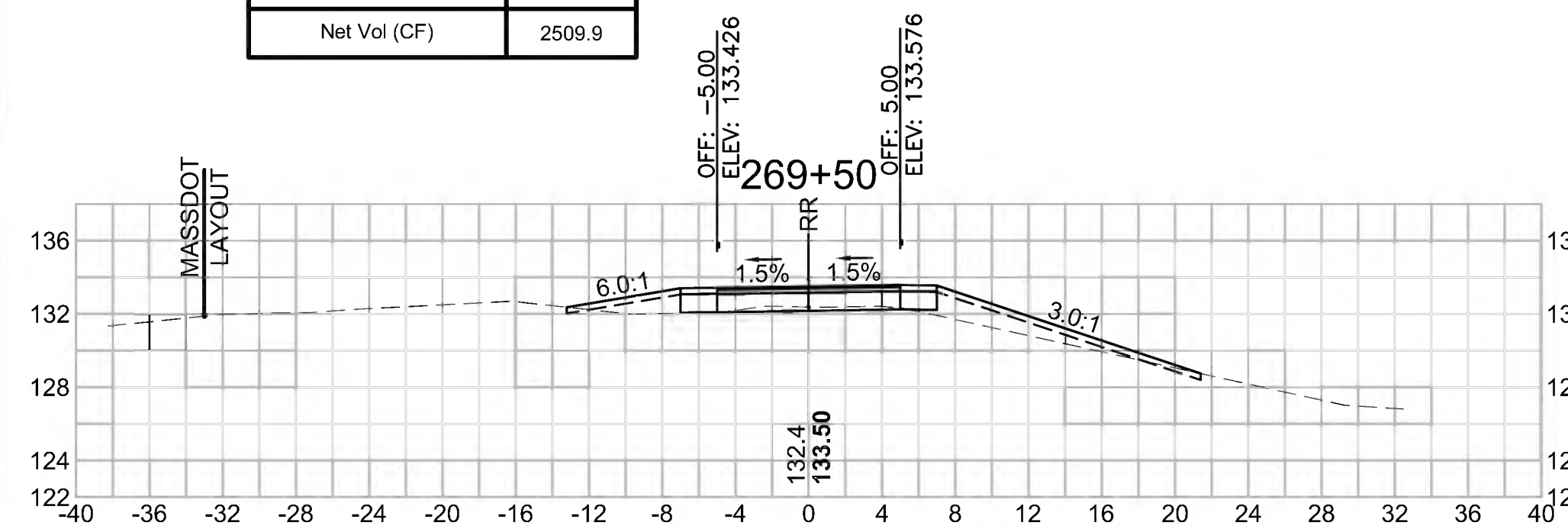

Total Volume at Station 271+00.00

Cut Area (SF)	4.887
Fill Area (SF)	7.726
Cut Vol (CF)	11.6
Fill Vol (CF)	11.6
Cum Cut Vol (CF)	10620.2
Cum Fill Vol (CF)	8085.3
Net Vol (CF)	2534.9

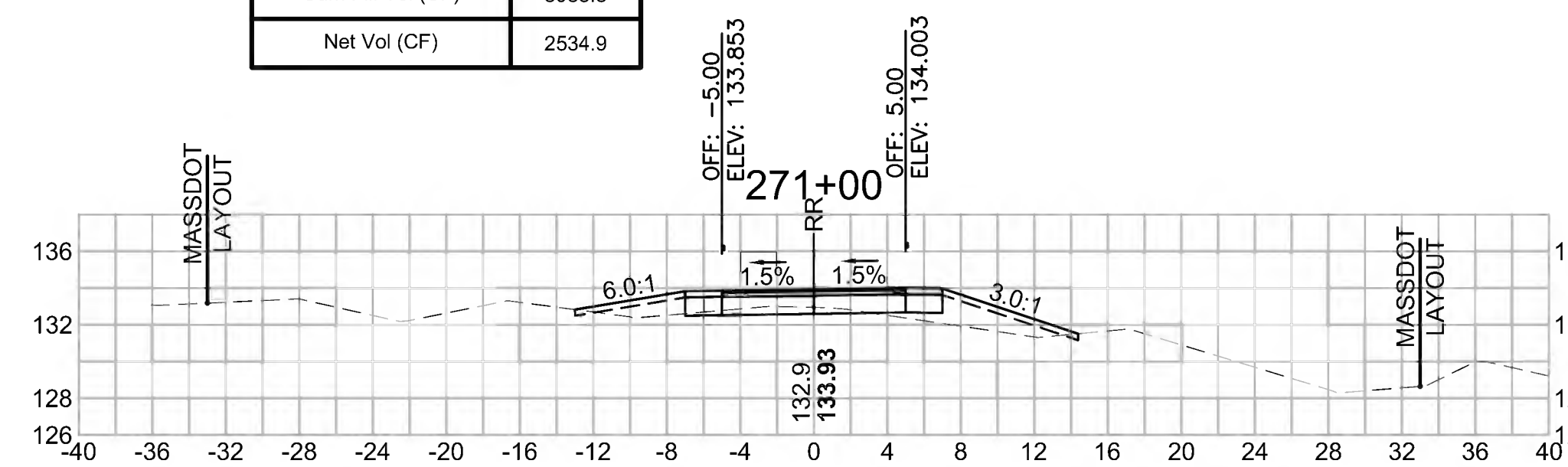

Total Volume at Station 272+50.00

Cut Area (SF)	9.303
Fill Area (SF)	6.077
Cut Vol (CF)	27.6
Fill Vol (CF)	9.1
Cum Cut Vol (CF)	10700.8
Cum Fill Vol (CF)	8110.8
Net Vol (CF)	2590.0

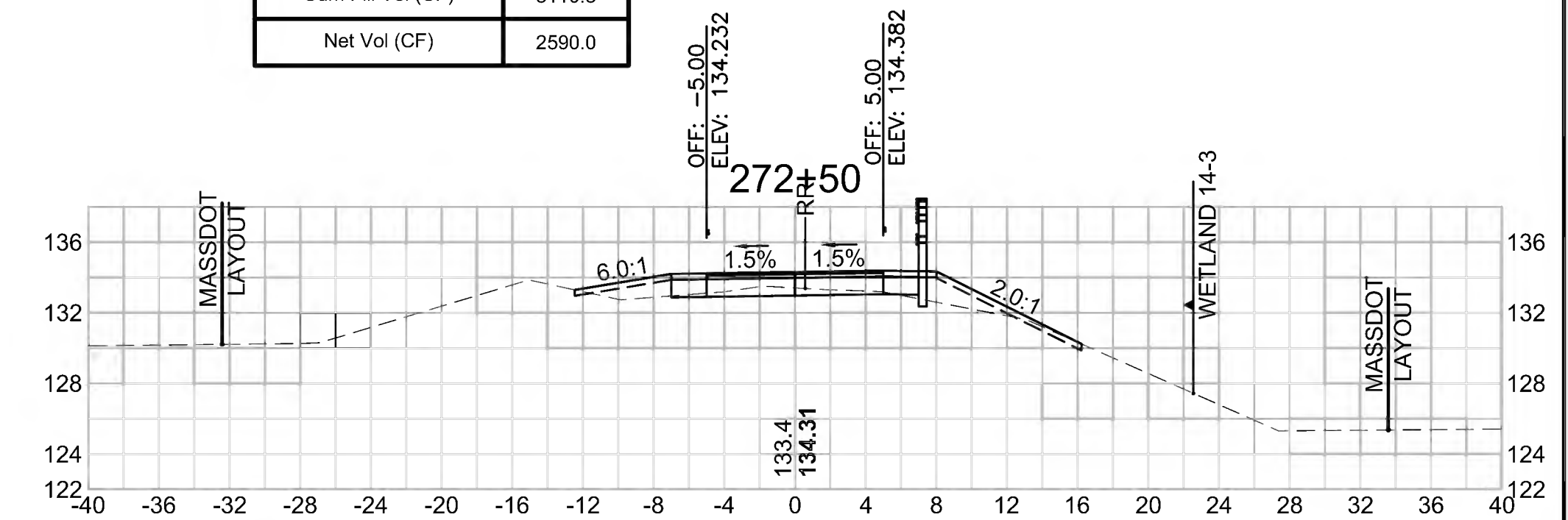

Total Volume at Station 269+00.00

Cut Area (SF)	5.848
Fill Area (SF)	11.181
Cut Vol (CF)	11.8
Fill Vol (CF)	15.8
Cum Cut Vol (CF)	10543.9
Cum Fill Vol (CF)	8030.0
Net Vol (CF)	2513.9

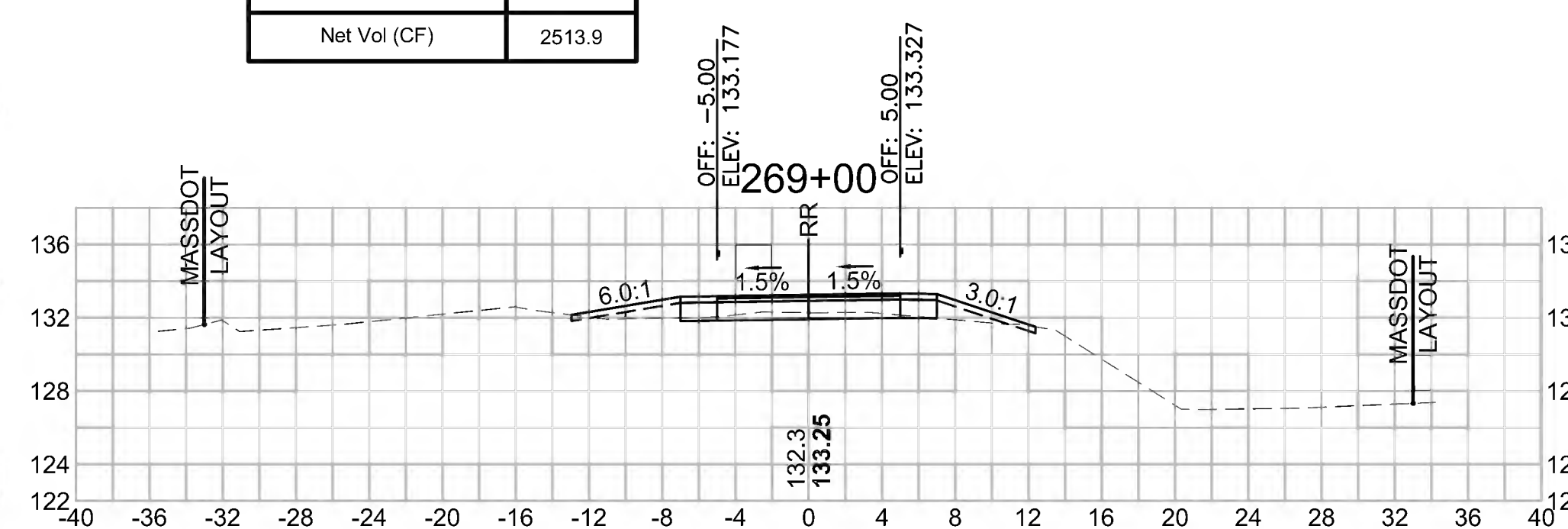

Total Volume at Station 270+50.00

Cut Area (SF)	7.611
Fill Area (SF)	4.837
Cut Vol (CF)	22.6
Fill Vol (CF)	9.2
Cum Cut Vol (CF)	10608.7
Cum Fill Vol (CF)	8073.7
Net Vol (CF)	2535.0

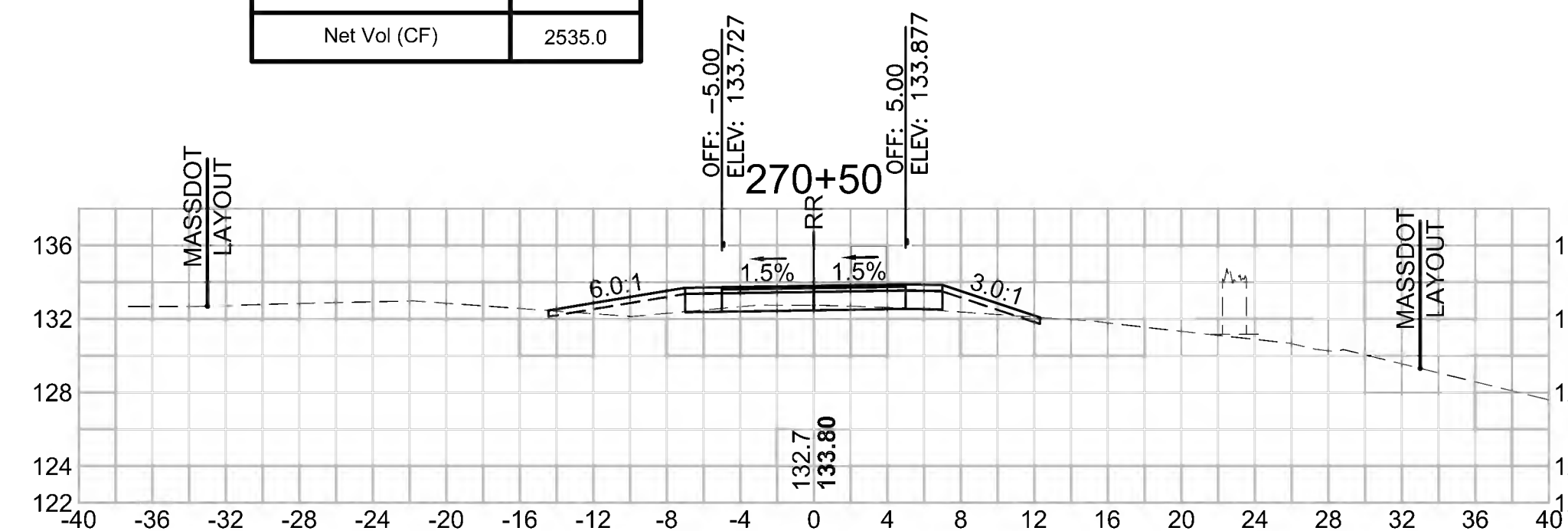

Total Volume at Station 272+00.00

Cut Area (SF)	20.499
Fill Area (SF)	3.749
Cut Vol (CF)	33.7
Fill Vol (CF)	6.3
Cum Cut Vol (CF)	10673.2
Cum Fill Vol (CF)	8101.7
Net Vol (CF)	2571.5

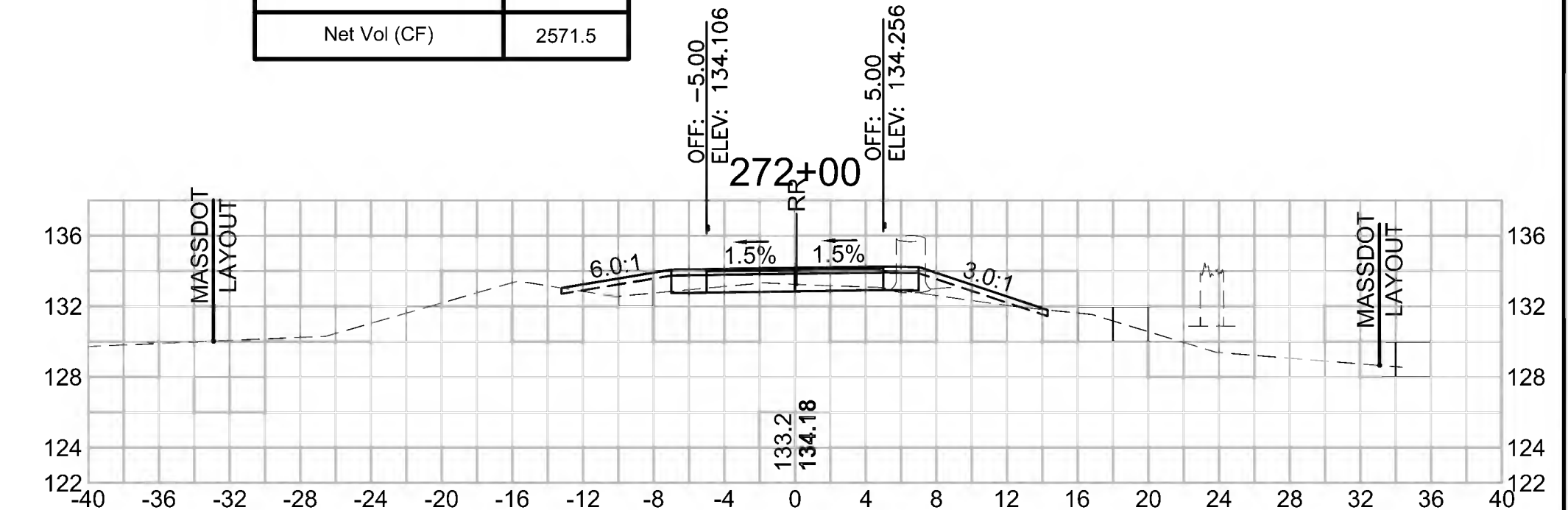

SUDBURY
BRUCE FREEMAN RAIL TRAIL

STATE	FED. AID PROJ. NO.	SHEET NO.	TOTAL SHEETS
MA	XXX-XXXX(XXX)X	286	319
PROJECT FILE NO. 608164			

CROSS SECTIONS

608164_XSEC(CROSS SECTION LAYOUTS).DWG 18-Feb-2022

Total Volume at Station 274+50.00	
Cut Area (SF)	24.549
Fill Area (SF)	6.144
Cut Vol (CF)	40.8
Fill Vol (CF)	18.1
Cum Cut Vol (CF)	10808.6
Cum Fill Vol (CF)	8156.7
Net Vol (CF)	2651.9

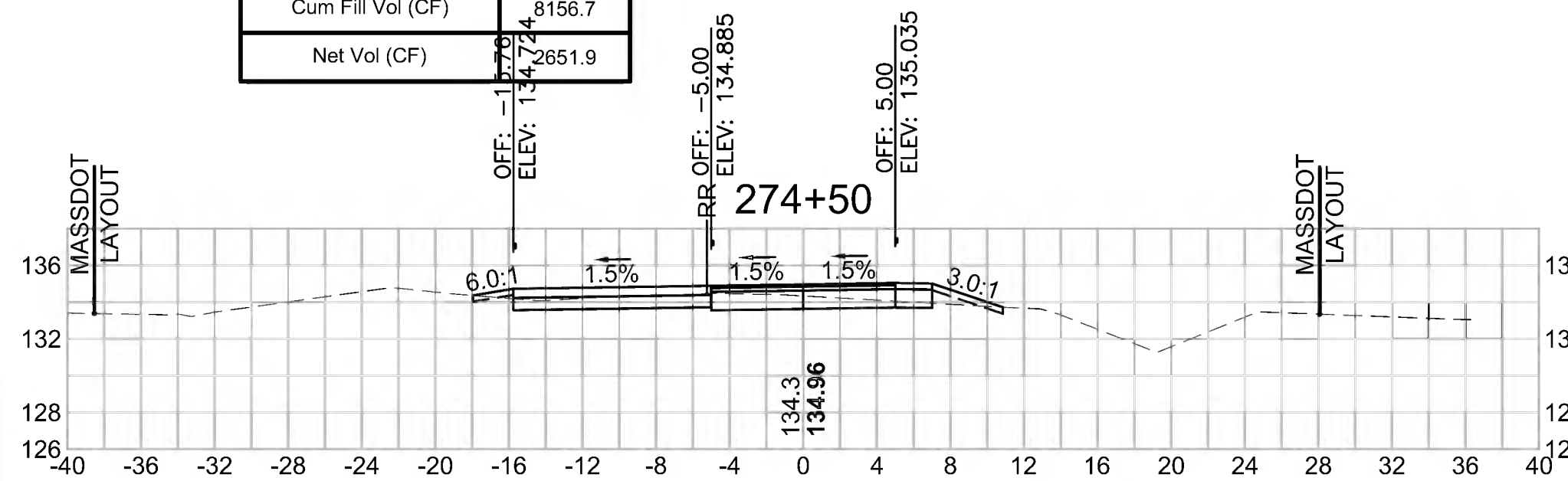

Total Volume at Station 276+00.00	
Cut Area (SF)	12.654
Fill Area (SF)	0.620
Cut Vol (CF)	27.6
Fill Vol (CF)	1.5
Cum Cut Vol (CF)	10955.2
Cum Fill Vol (CF)	8164.8
Net Vol (CF)	2790.4

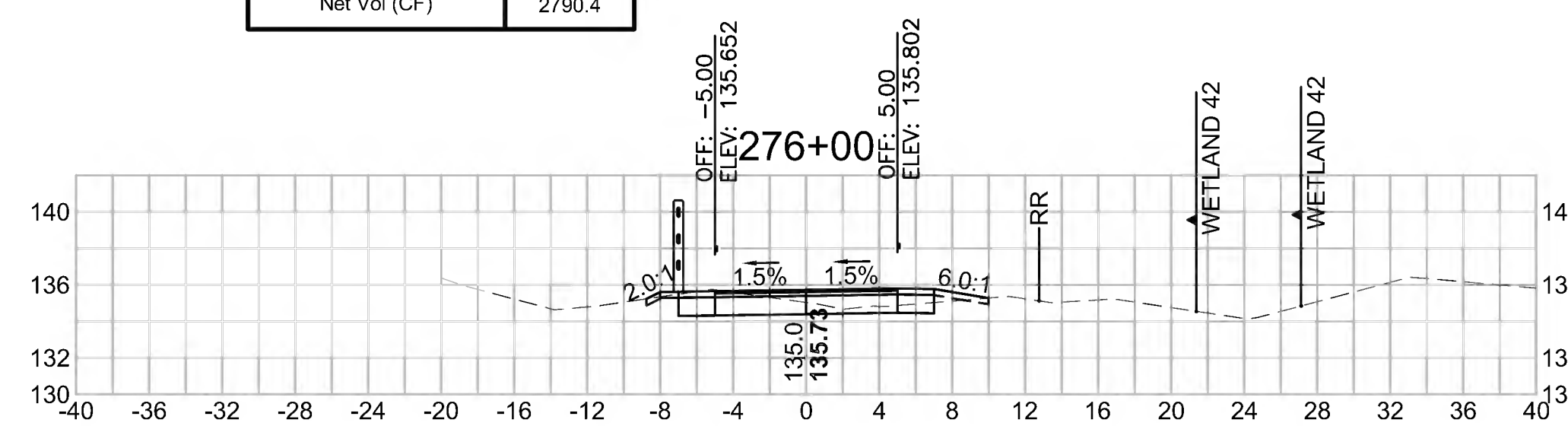

Total Volume at Station 274+00.00	
Cut Area (SF)	19.468
Fill Area (SF)	13.388
Cut Vol (CF)	30.6
Fill Vol (CF)	14.3
Cum Cut Vol (CF)	10767.9
Cum Fill Vol (CF)	8138.6
Net Vol (CF)	2629.3

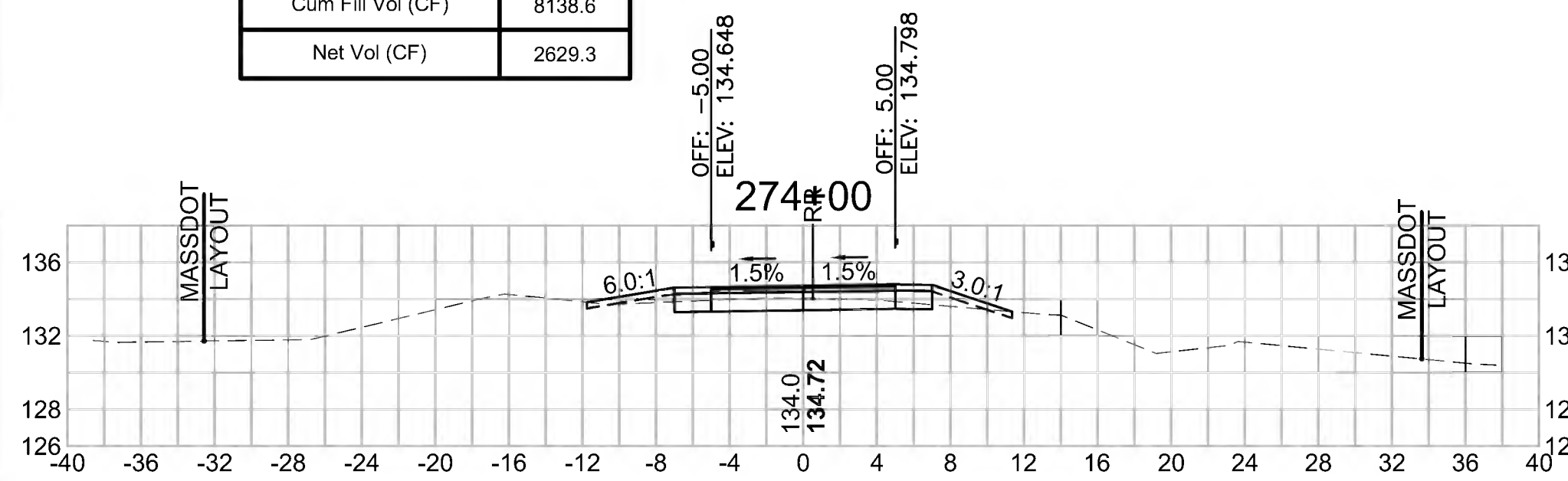

Total Volume at Station 275+50.00	
Cut Area (SF)	17.120
Fill Area (SF)	1.005
Cut Vol (CF)	56.1
Fill Vol (CF)	0.9
Cum Cut Vol (CF)	10927.6
Cum Fill Vol (CF)	8163.3
Net Vol (CF)	2764.3

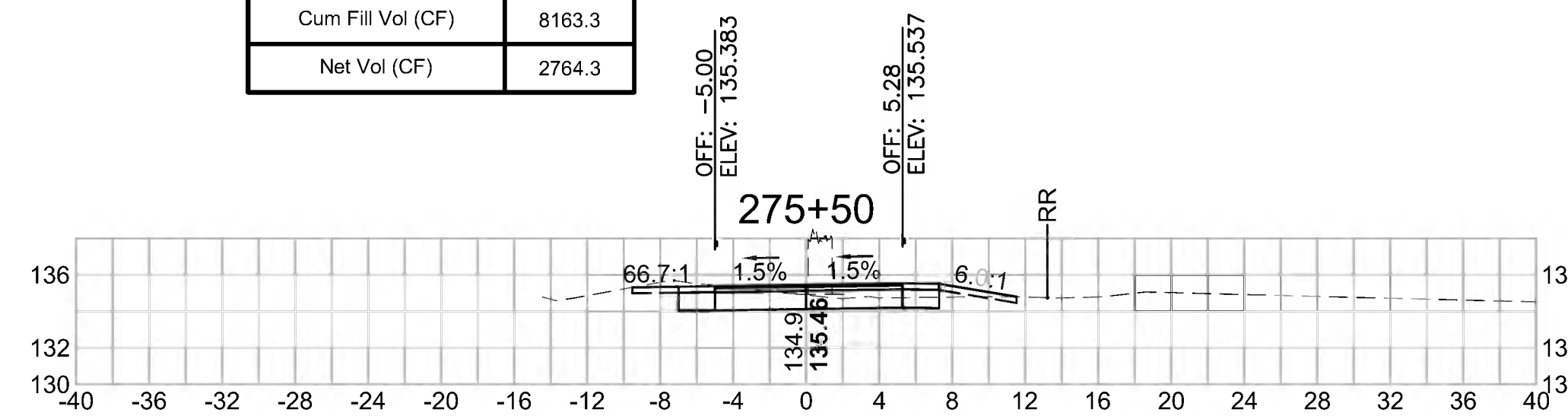

Total Volume at Station 273+50.00	
Cut Area (SF)	13.567
Fill Area (SF)	2.075
Cut Vol (CF)	20.2
Fill Vol (CF)	4.9
Cum Cut Vol (CF)	10737.3
Cum Fill Vol (CF)	8124.3
Net Vol (CF)	2613.0

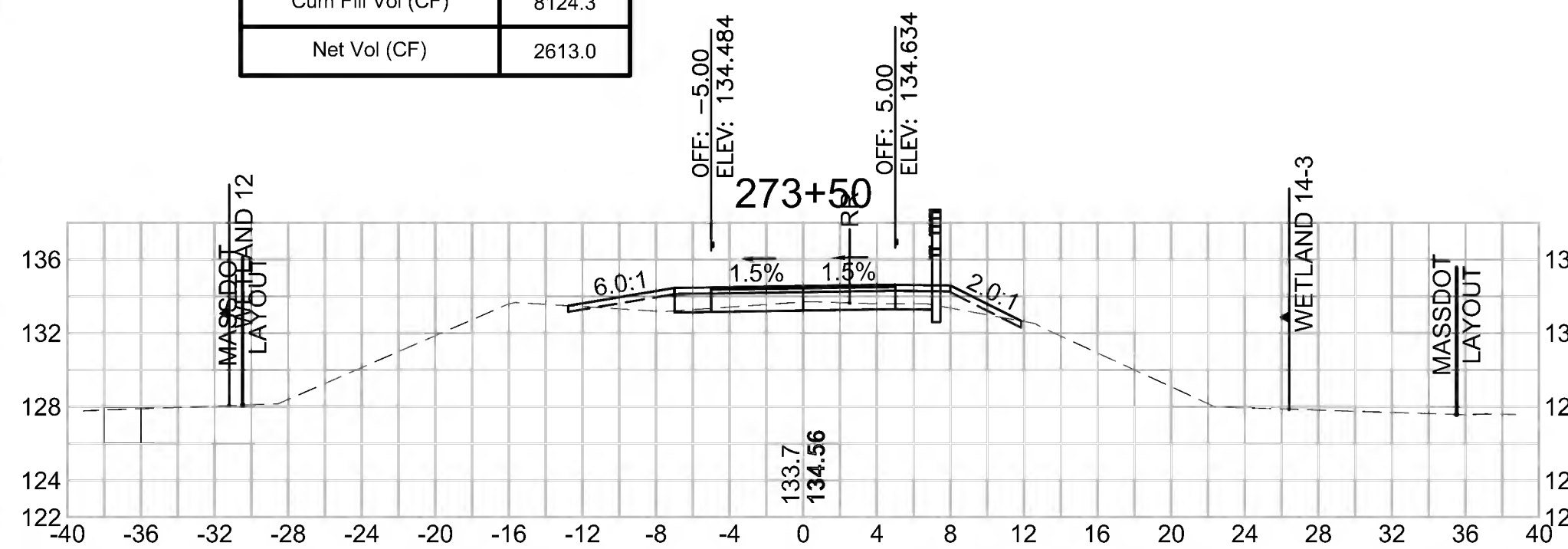

Total Volume at Station 275+00.00	
Cut Area (SF)	43.439
Fill Area (SF)	0.000
Cut Vol (CF)	63.0
Fill Vol (CF)	5.7
Cum Cut Vol (CF)	10871.6
Cum Fill Vol (CF)	8162.4
Net Vol (CF)	2709.2

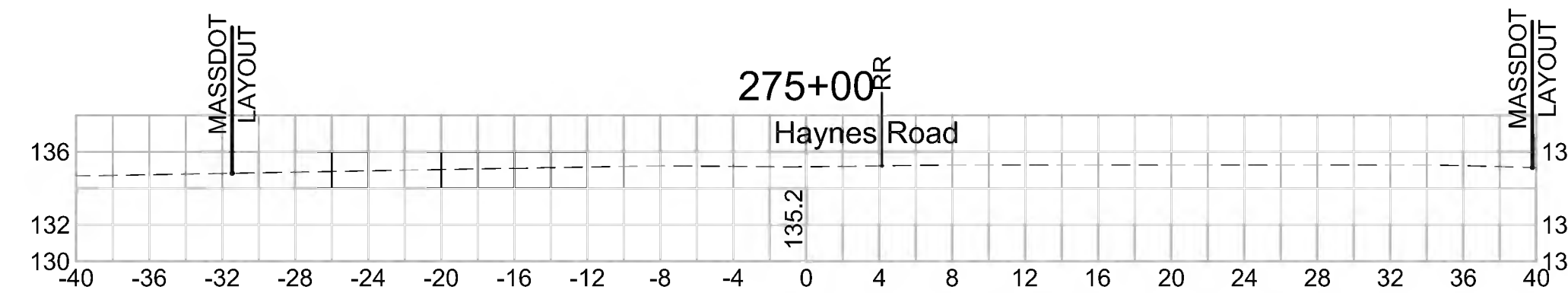

CROSS SECTIONS

Total Volume at Station 277+50.00	
Cut Area (SF)	9.978
Fill Area (SF)	0.269
Cut Vol (CF)	15.8
Fill Vol (CF)	0.3
Cum Cut Vol (CF)	11008.5
Cum Fill Vol (CF)	8165.8
Net Vol (CF)	2842.7

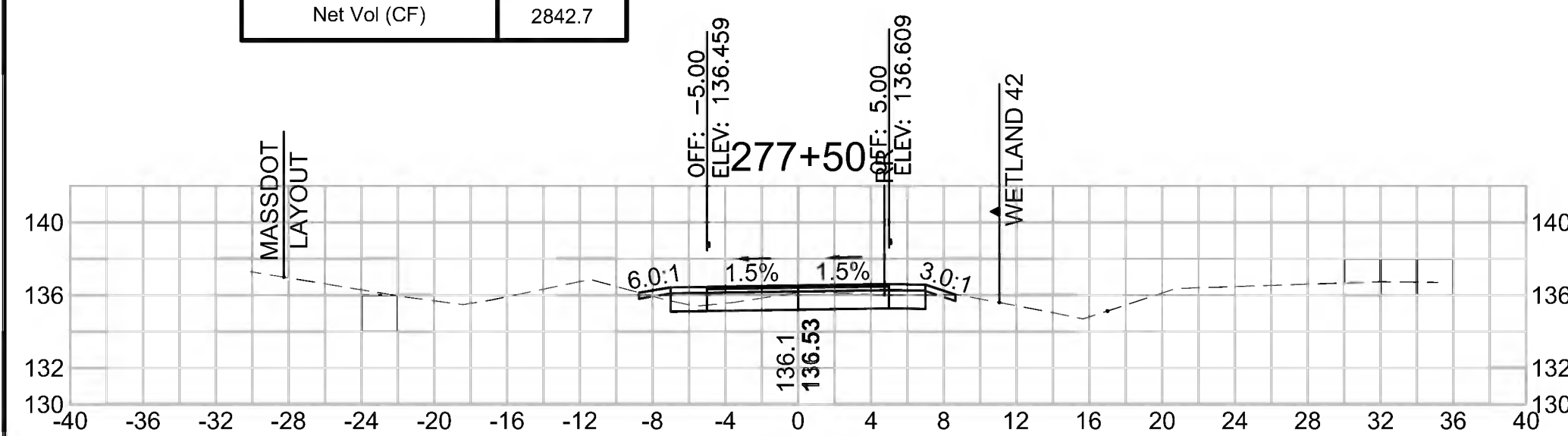

Total Volume at Station 279+00.00	
Cut Area (SF)	9.292
Fill Area (SF)	0.846
Cut Vol (CF)	17.6
Fill Vol (CF)	1.2
Cum Cut Vol (CF)	11061.7
Cum Fill Vol (CF)	8168.9
Net Vol (CF)	2892.7

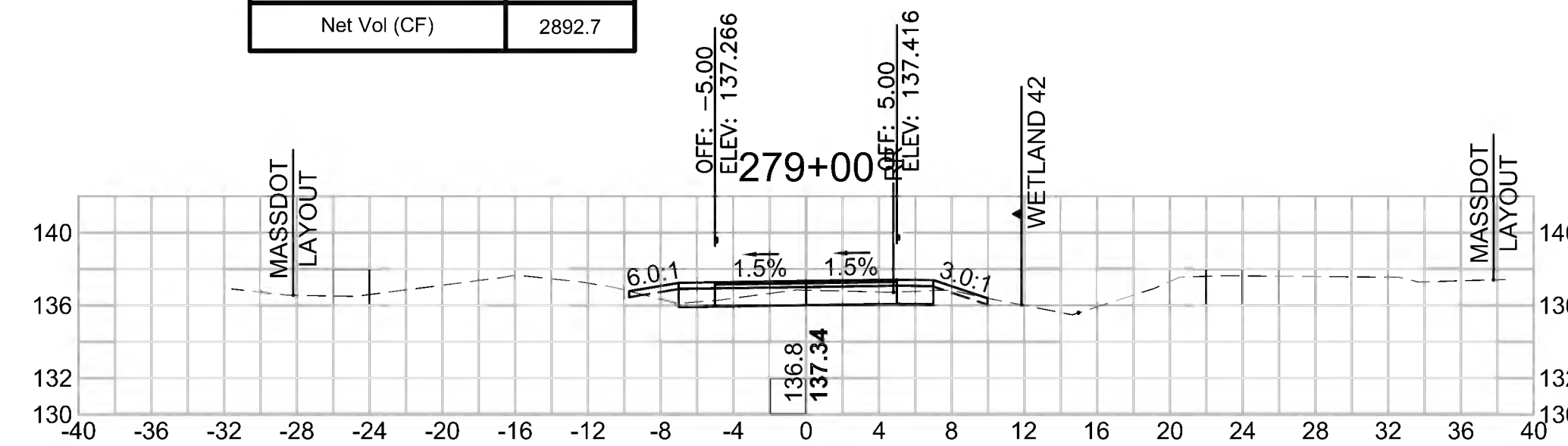

Total Volume at Station 280+50.00	
Cut Area (SF)	8.526
Fill Area (SF)	0.500
Cut Vol (CF)	15.8
Fill Vol (CF)	1.5
Cum Cut Vol (CF)	11111.5
Cum Fill Vol (CF)	8173.5
Net Vol (CF)	2937.9

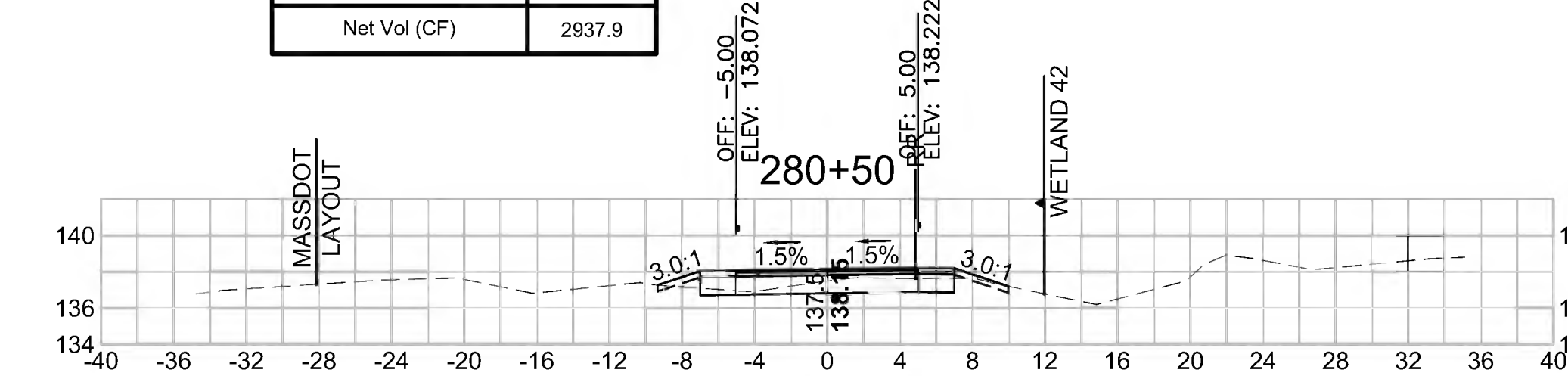

Total Volume at Station 277+00.00	
Cut Area (SF)	7.093
Fill Area (SF)	0.066
Cut Vol (CF)	16.2
Fill Vol (CF)	0.1
Cum Cut Vol (CF)	10992.7
Cum Fill Vol (CF)	8165.5
Net Vol (CF)	2827.2

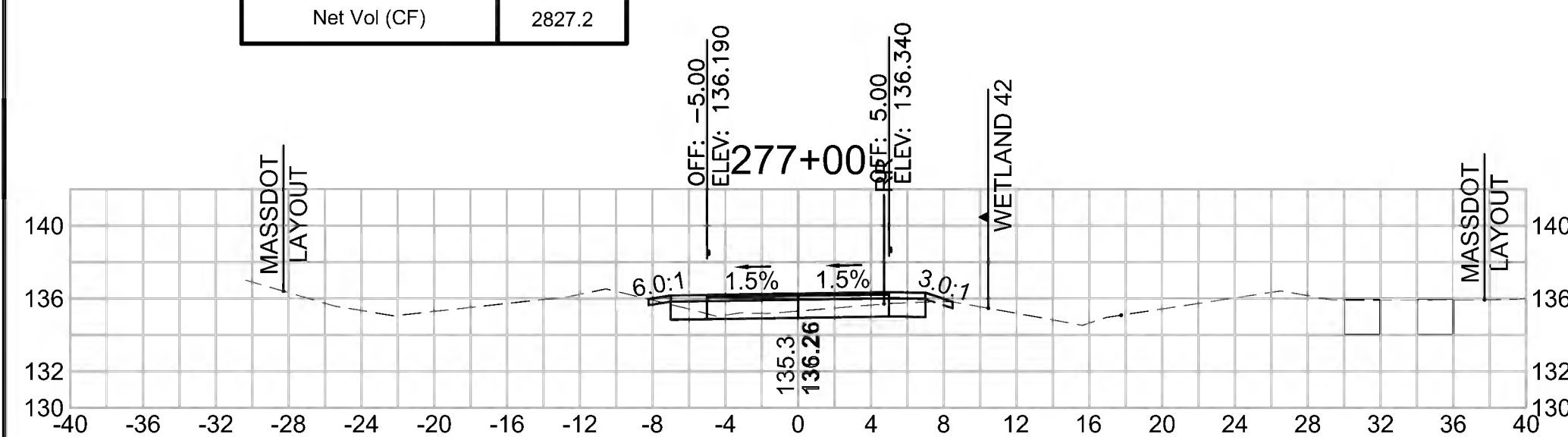

Total Volume at Station 278+50.00	
Cut Area (SF)	9.760
Fill Area (SF)	0.426
Cut Vol (CF)	17.7
Fill Vol (CF)	1.0
Cum Cut Vol (CF)	11044.0
Cum Fill Vol (CF)	8167.8
Net Vol (CF)	2876.3

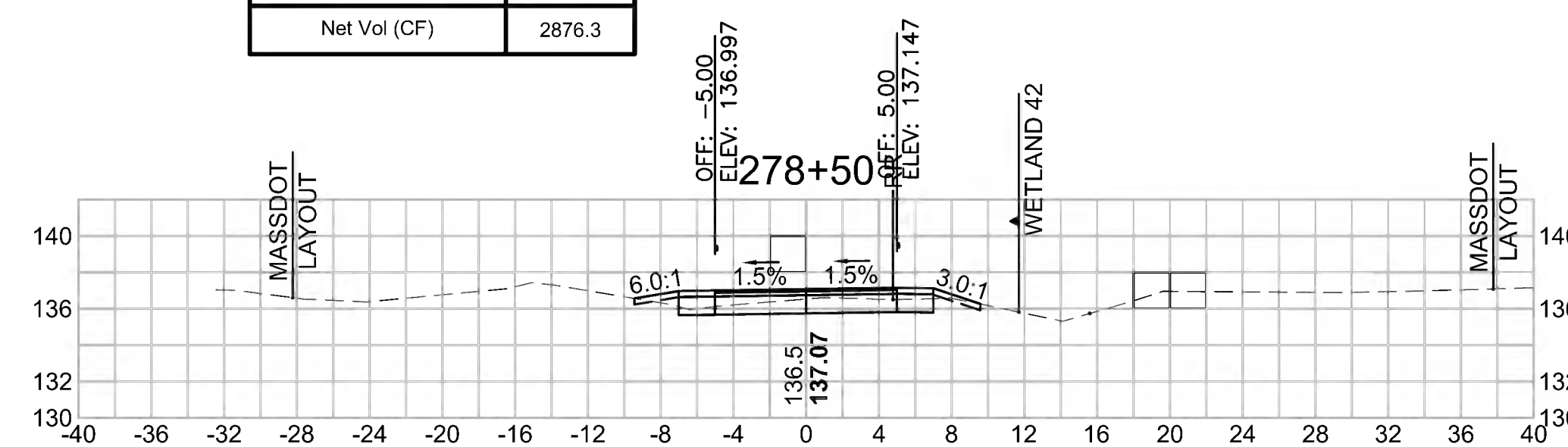

Total Volume at Station 280+00.00	
Cut Area (SF)	8.550
Fill Area (SF)	1.082
Cut Vol (CF)	16.6
Fill Vol (CF)	1.7
Cum Cut Vol (CF)	11095.6
Cum Fill Vol (CF)	8172.0
Net Vol (CF)	2923.6

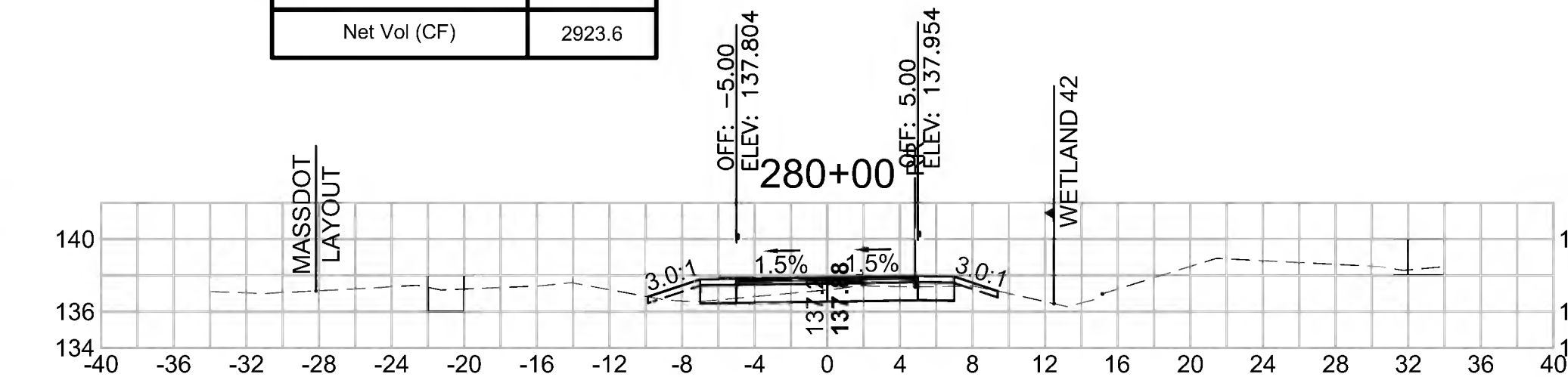

Total Volume at Station 276+50.00	
Cut Area (SF)	10.381
Fill Area (SF)	0.043
Cut Vol (CF)	21.3
Fill Vol (CF)	0.6
Cum Cut Vol (CF)	10976.5
Cum Fill Vol (CF)	8165.4
Net Vol (CF)	2811.1

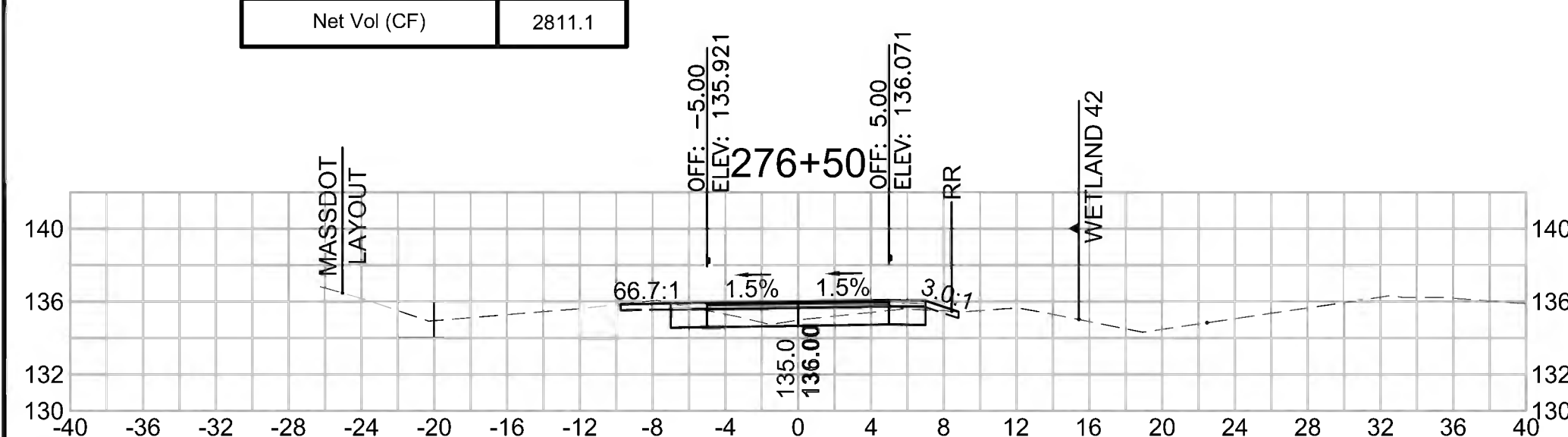

Total Volume at Station 278+00.00	
Cut Area (SF)	9.312
Fill Area (SF)	0.703
Cut Vol (CF)	17.9
Fill Vol (CF)	0.9
Cum Cut Vol (CF)	11026.4
Cum Fill Vol (CF)	8166.7
Net Vol (CF)	2859.7

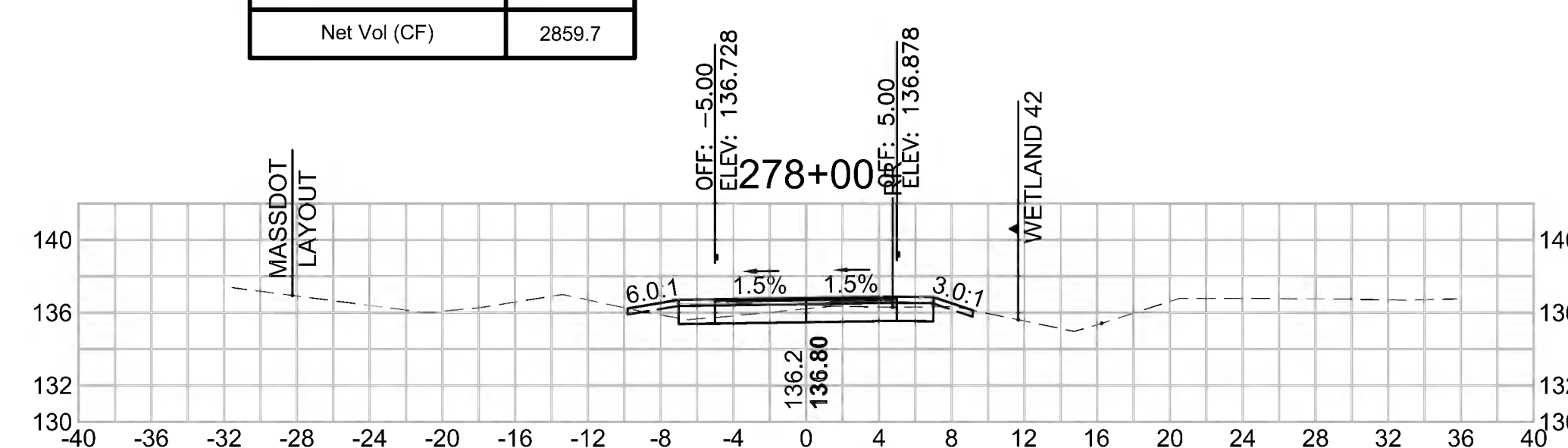

Total Volume at Station 279+50.00	
Cut Area (SF)	9.420
Fill Area (SF)	0.707
Cut Vol (CF)	17.3
Fill Vol (CF)	1.4
Cum Cut Vol (CF)	11079.0
Cum Fill Vol (CF)	8170.4
Net Vol (CF)	2908.6

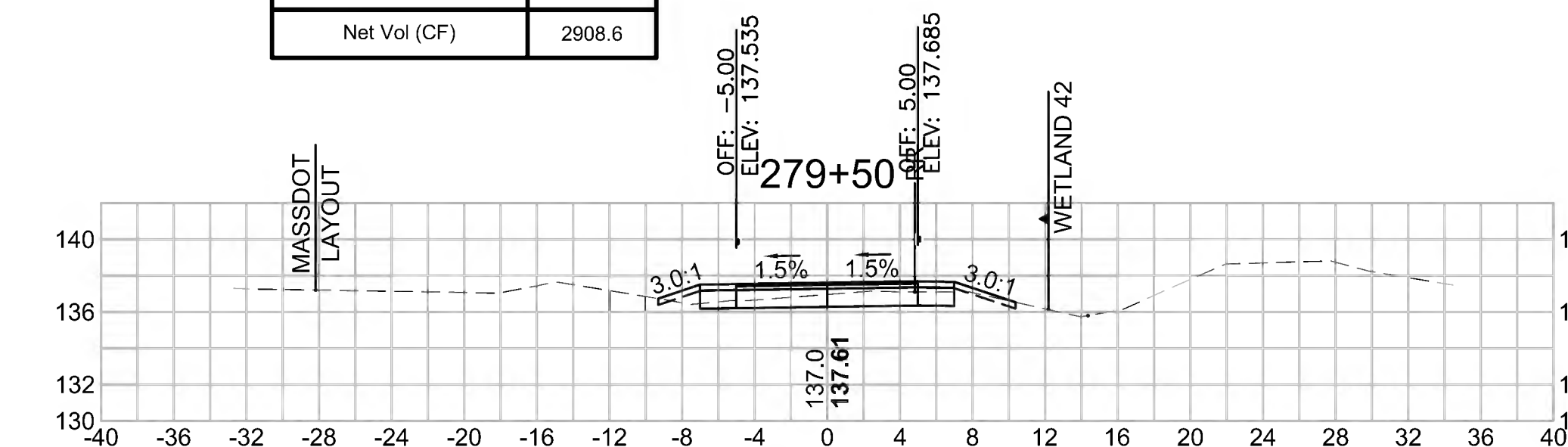

SUDBURY
BRUCE FREEMAN RAIL TRAIL

STATE	FED. AID PROJ. NO.	SHEET NO.	TOTAL SHEETS
MA	XXX-XXX(XXX)X	288	319

PROJECT FILE NO. 608164

CROSS SECTIONS

608164_XSEC(CROSS SECTION LAYOUTS).DWG 18-Feb-2022

Total Volume at Station 282+00.00

Cut Area (SF)	28.258
Fill Area (SF)	0.000
Cut Vol (CF)	40.9
Fill Vol (CF)	0.1
Cum Cut Vol (CF)	11192.0
Cum Fill Vol (CF)	8174.8
Net Vol (CF)	3017.2

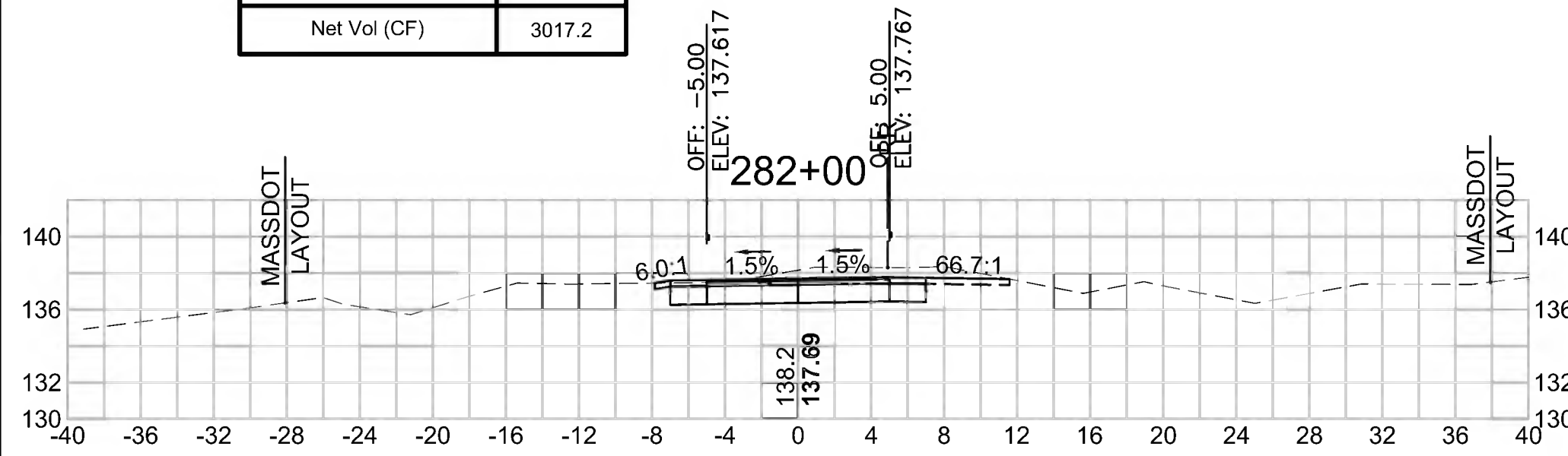

Total Volume at Station 283+50.00

Cut Area (SF)	59.185
Fill Area (SF)	0.222
Cut Vol (CF)	105.4
Fill Vol (CF)	0.2
Cum Cut Vol (CF)	11454.4
Cum Fill Vol (CF)	8175.0
Net Vol (CF)	3279.4

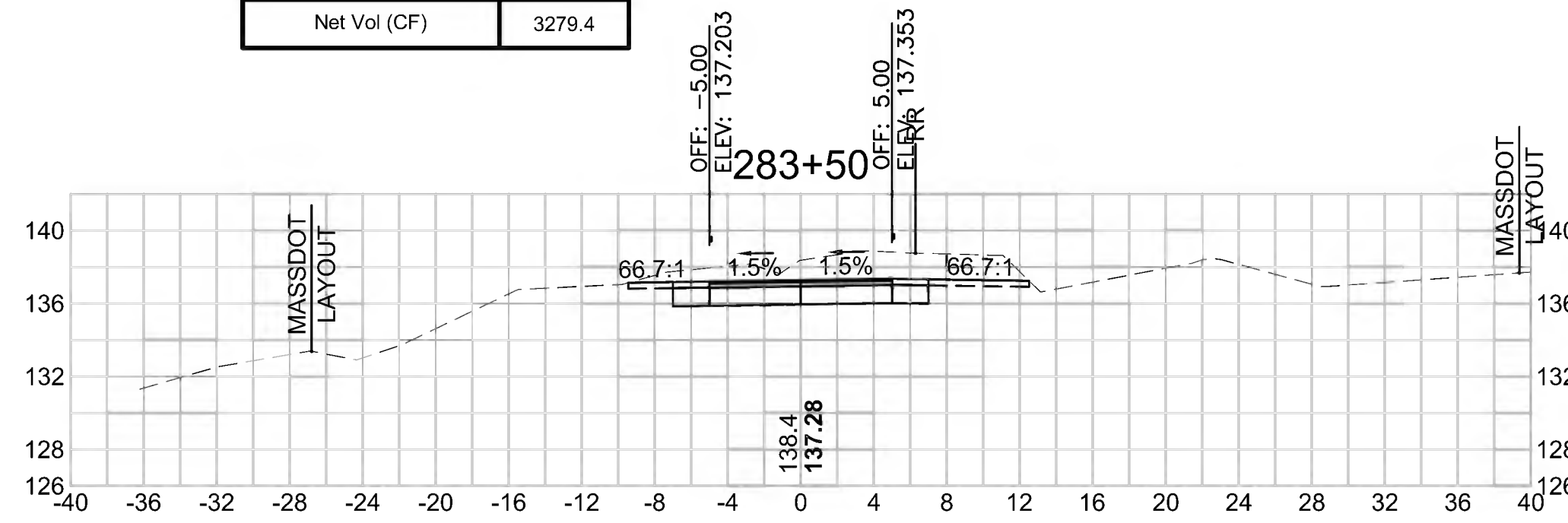

Total Volume at Station 285+00.00

Cut Area (SF)	51.764
Fill Area (SF)	6.023
Cut Vol (CF)	47.9
Fill Vol (CF)	5.6
Cum Cut Vol (CF)	11617.4
Cum Fill Vol (CF)	8185.3
Net Vol (CF)	3432.0

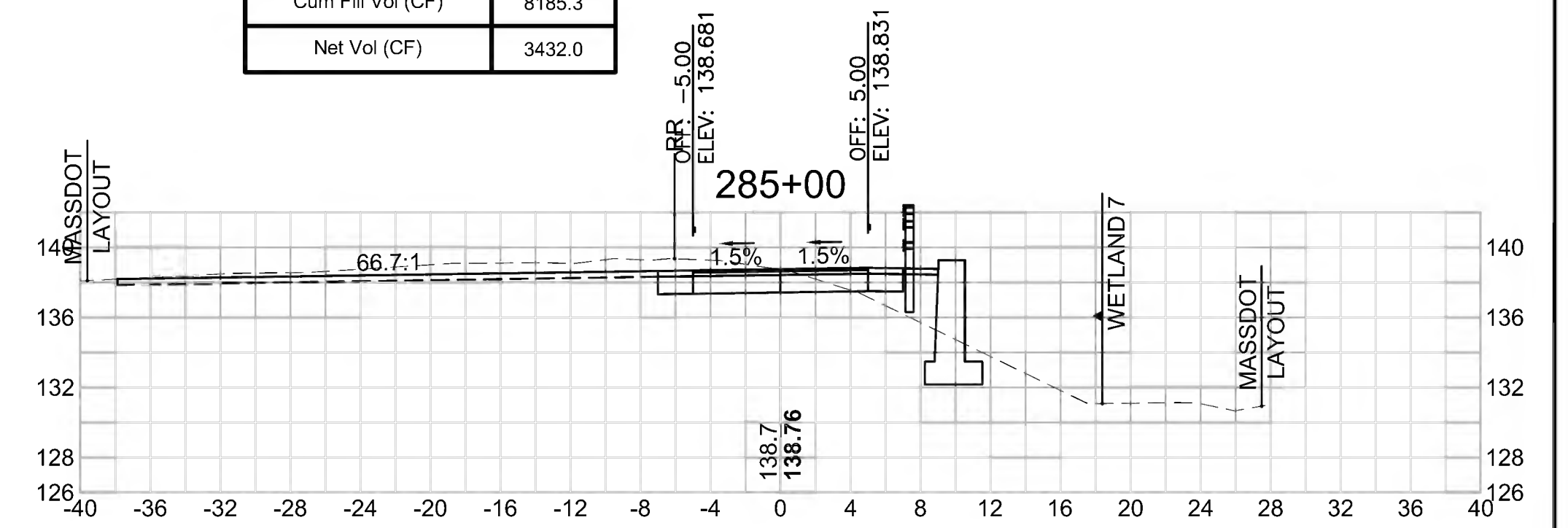

Total Volume at Station 281+50.00

Cut Area (SF)	15.927
Fill Area (SF)	0.106
Cut Vol (CF)	23.2
Fill Vol (CF)	0.4
Cum Cut Vol (CF)	11151.1
Cum Fill Vol (CF)	8174.7
Net Vol (CF)	2976.4

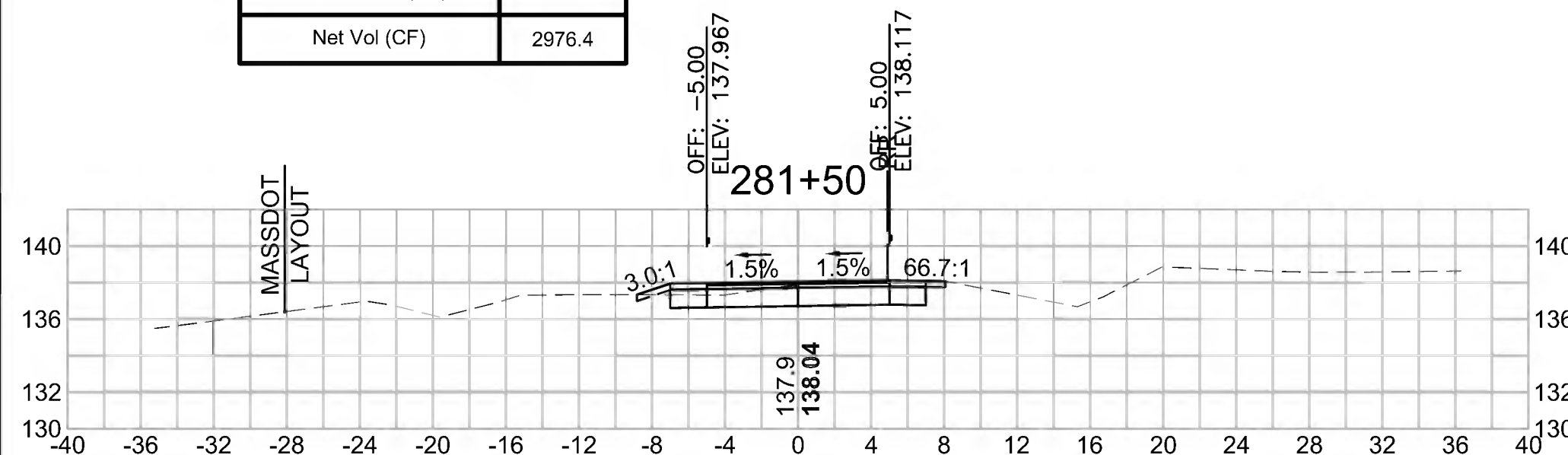

Total Volume at Station 283+00.00

Cut Area (SF)	54.652
Fill Area (SF)	0.000
Cut Vol (CF)	90.7
Fill Vol (CF)	0.0
Cum Cut Vol (CF)	11349.0
Cum Fill Vol (CF)	8174.8
Net Vol (CF)	3174.2

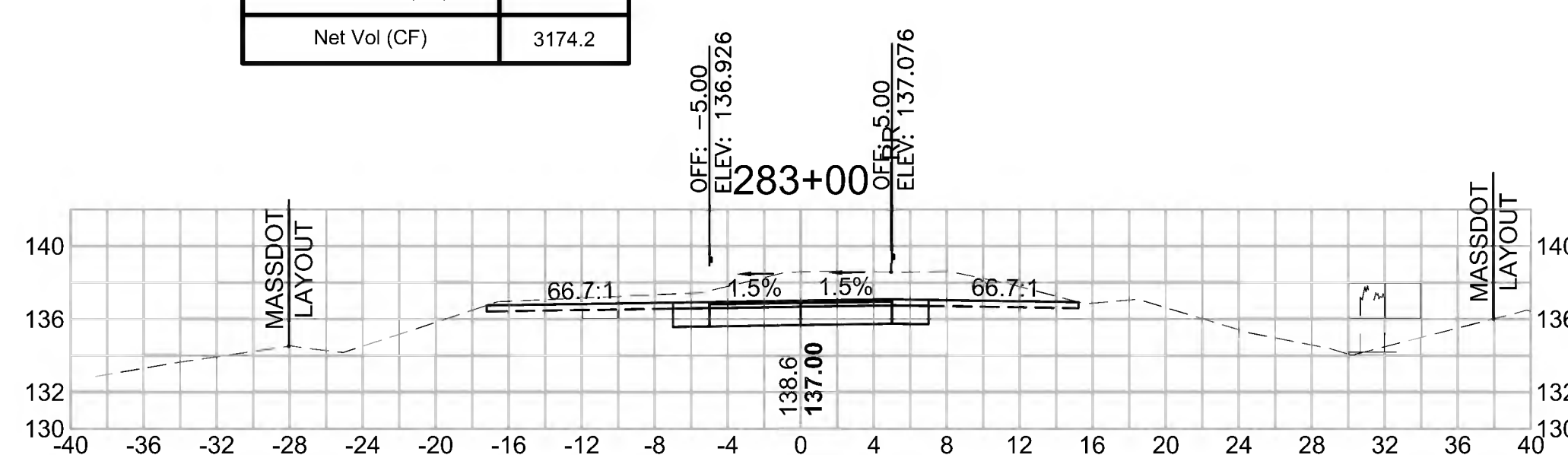

Total Volume at Station 284+50.00

Cut Area (SF)	0.000
Fill Area (SF)	0.000
Cut Vol (CF)	30.1
Fill Vol (CF)	2.3
Cum Cut Vol (CF)	11569.5
Cum Fill Vol (CF)	8179.8
Net Vol (CF)	3389.7

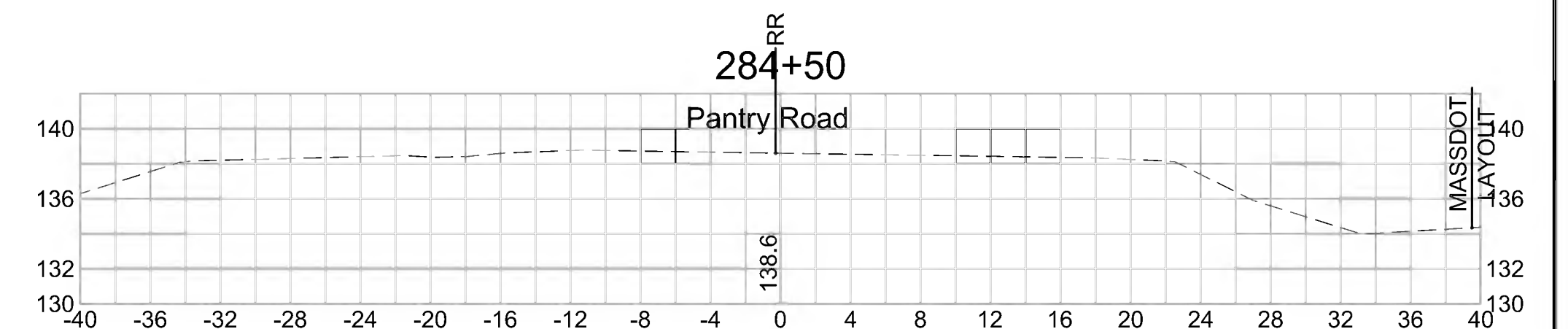

Total Volume at Station 281+00.00

Cut Area (SF)	9.182
Fill Area (SF)	0.352
Cut Vol (CF)	16.4
Fill Vol (CF)	0.8
Cum Cut Vol (CF)	11127.9
Cum Fill Vol (CF)	8174.3
Net Vol (CF)	2953.6

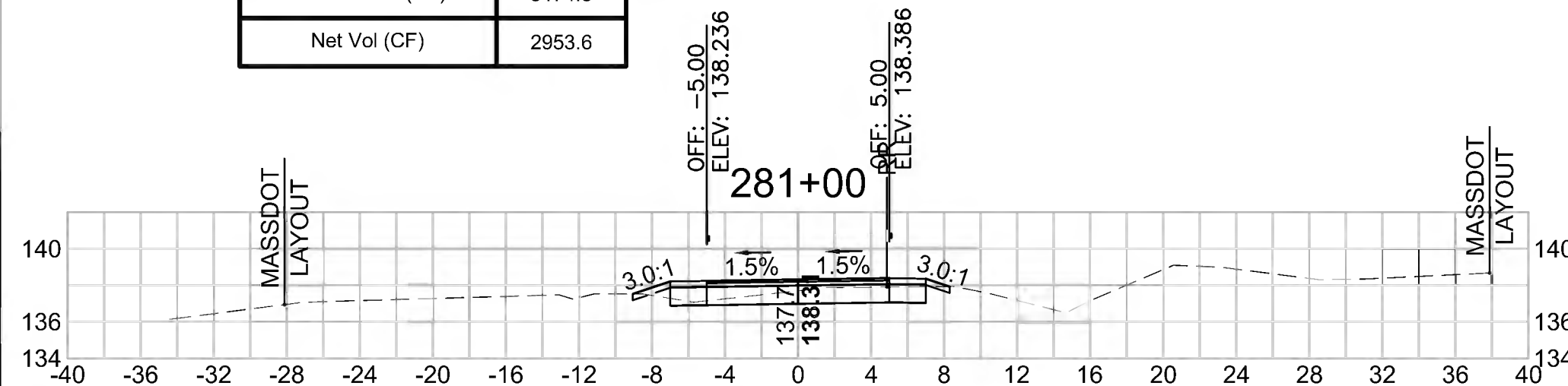

Total Volume at Station 282+50.00

Cut Area (SF)	43.320
Fill Area (SF)	0.000
Cut Vol (CF)	66.3
Fill Vol (CF)	0.0
Cum Cut Vol (CF)	11258.3
Cum Fill Vol (CF)	8174.8
Net Vol (CF)	3083.5

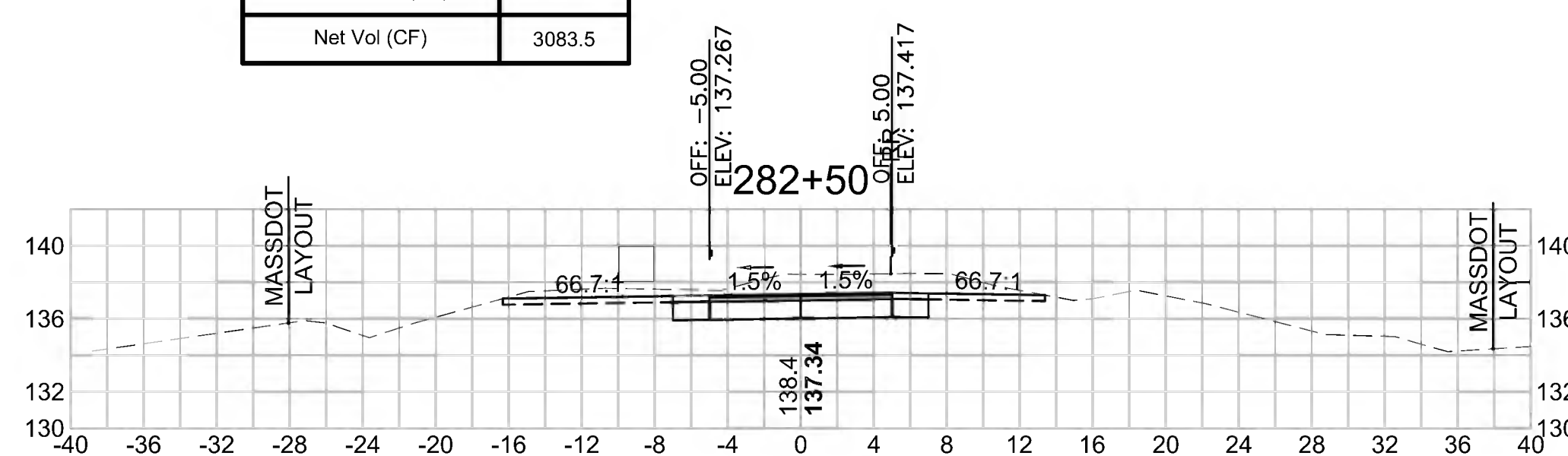

Total Volume at Station 284+00.00

Cut Area (SF)	32.535
Fill Area (SF)	2.450
Cut Vol (CF)	84.9
Fill Vol (CF)	2.5
Cum Cut Vol (CF)	11539.3
Cum Fill Vol (CF)	8177.5
Net Vol (CF)	3361.8

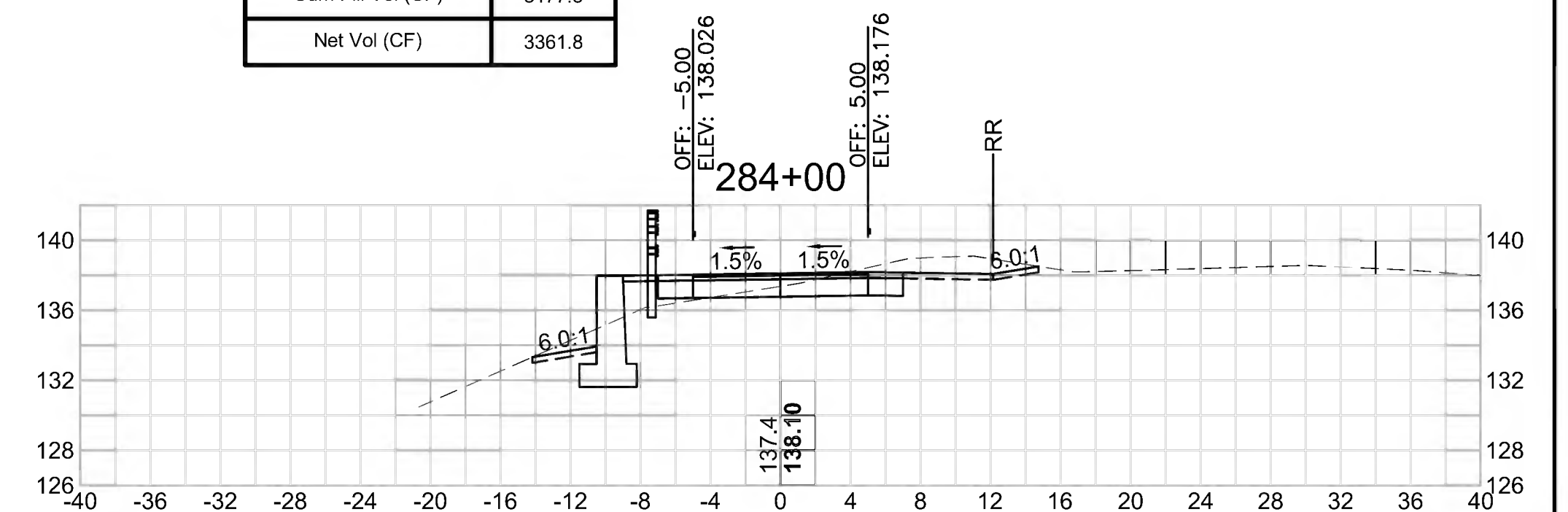

SUDBURY
BRUCE FREEMAN RAIL TRAIL

STATE	FED. AID PROJ. NO.	SHEET NO.	TOTAL SHEETS
MA	XXX-XXXX(XXX)X	289	319
PROJECT FILE NO. 608164			

CROSS SECTIONS

Total Volume at Station 286+50.00

Cut Area (SF)	10.652
Fill Area (SF)	2.537
Cut Vol (CF)	22.5
Fill Vol (CF)	3.7
Cum Cut Vol (CF)	11735.8
Cum Fill Vol (CF)	8201.9
Net Vol (CF)	3533.9

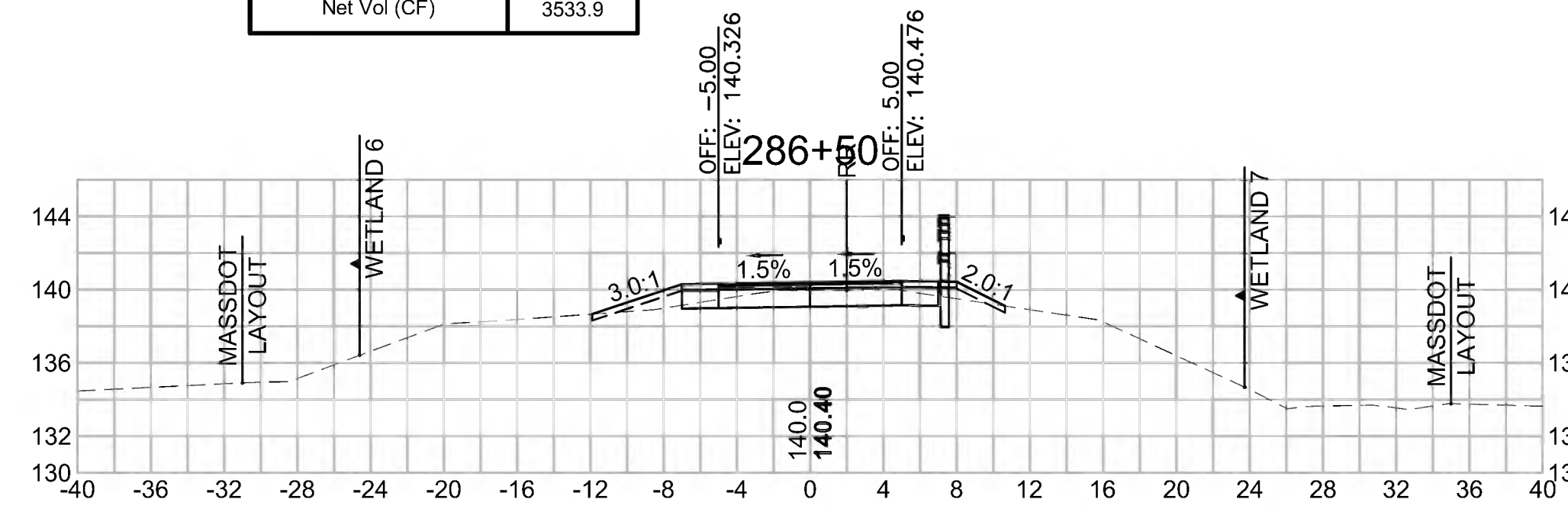

Total Volume at Station 288+00.00

Cut Area (SF)	10.395
Fill Area (SF)	6.320
Cut Vol (CF)	22.4
Fill Vol (CF)	11.9
Cum Cut Vol (CF)	11796.0
Cum Fill Vol (CF)	8228.4
Net Vol (CF)	3567.6

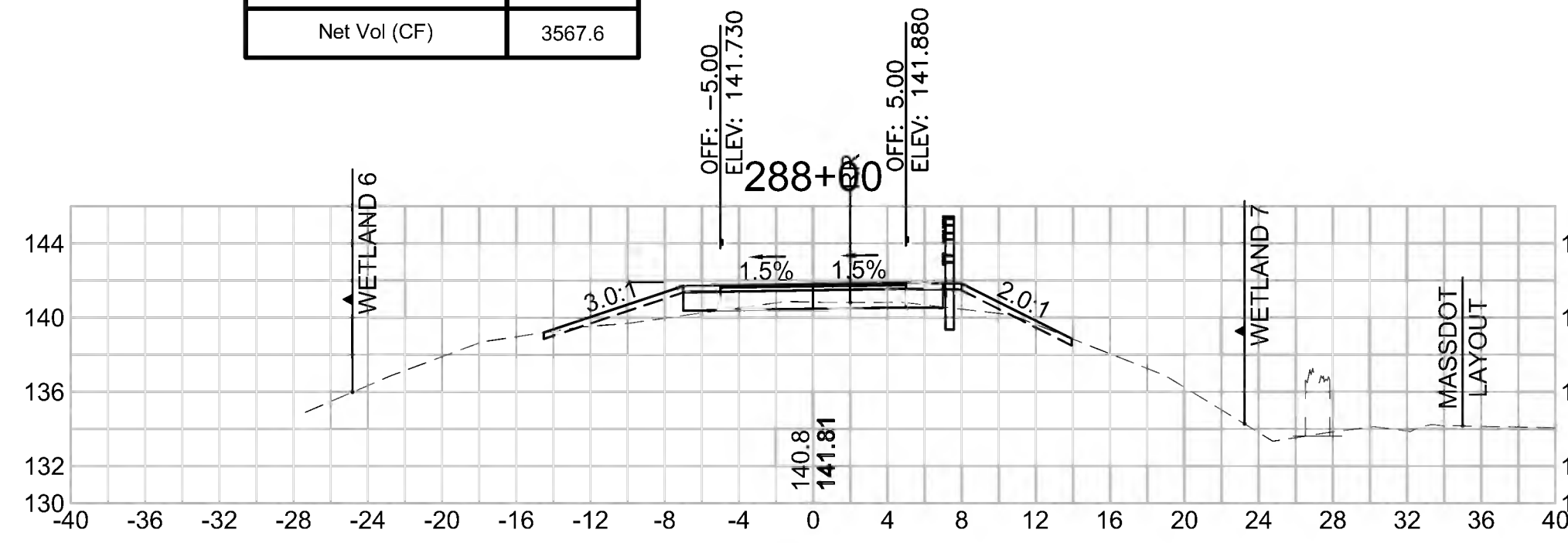

Total Volume at Station 289+50.00

Cut Area (SF)	7.485
Fill Area (SF)	3.349
Cut Vol (CF)	12.2
Fill Vol (CF)	7.5
Cum Cut Vol (CF)	11850.3
Cum Fill Vol (CF)	8257.9
Net Vol (CF)	3592.4

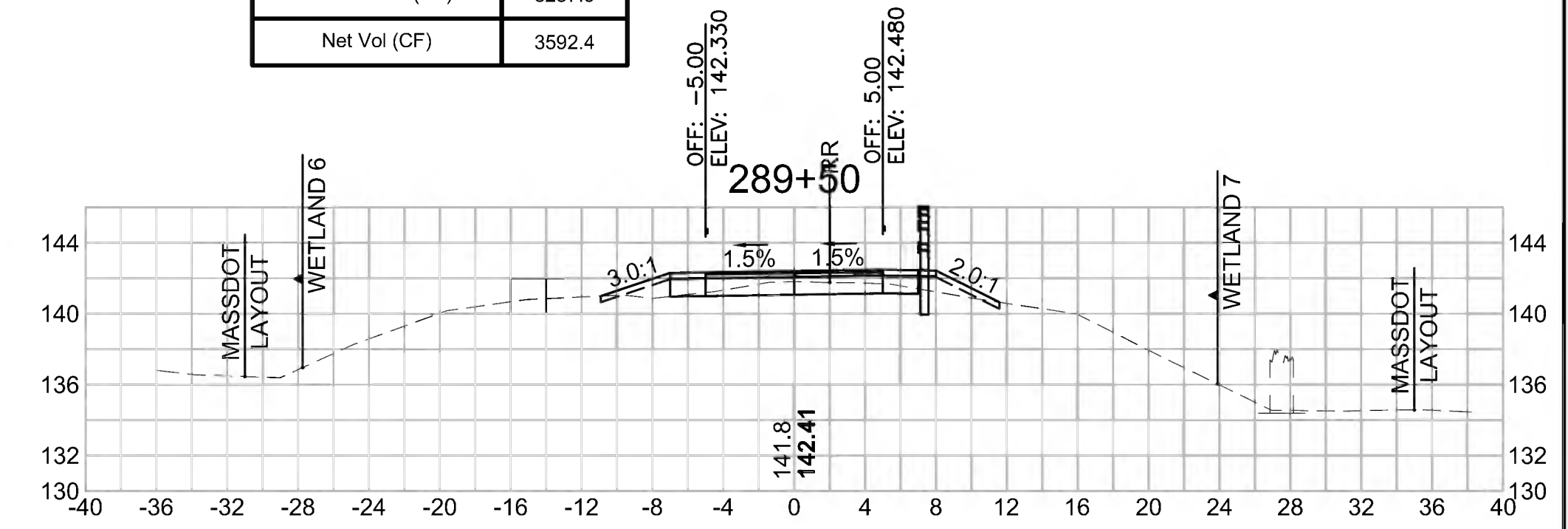

Total Volume at Station 286+00.00

Cut Area (SF)	13.658
Fill Area (SF)	1.480
Cut Vol (CF)	30.3
Fill Vol (CF)	4.3
Cum Cut Vol (CF)	11713.3
Cum Fill Vol (CF)	8198.2
Net Vol (CF)	3515.1

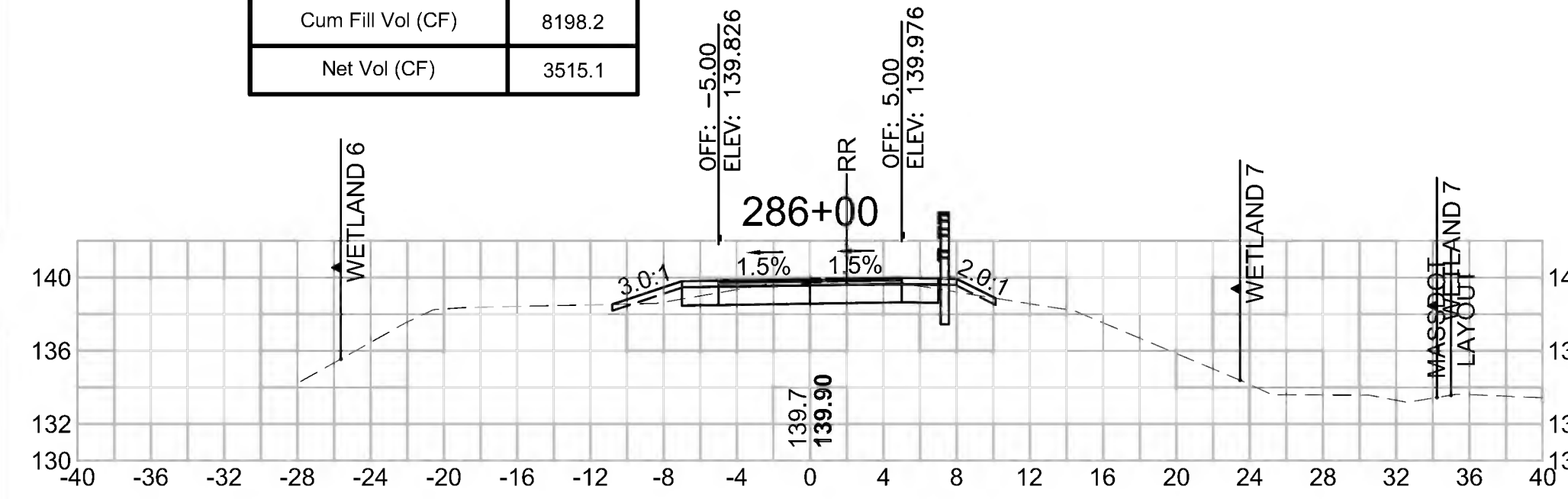

Total Volume at Station 287+50.00

Cut Area (SF)	13.780
Fill Area (SF)	6.505
Cut Vol (CF)	20.4
Fill Vol (CF)	9.1
Cum Cut Vol (CF)	11773.6
Cum Fill Vol (CF)	8216.5
Net Vol (CF)	3557.1

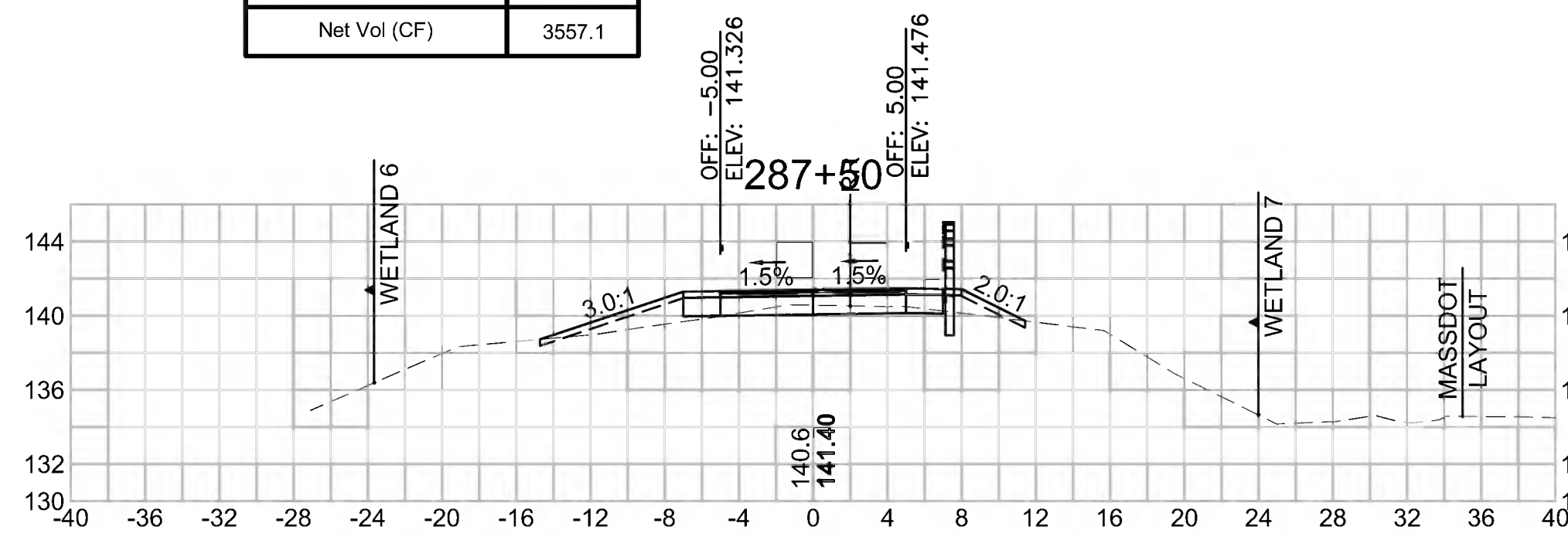

Total Volume at Station 289+00.00

Cut Area (SF)	5.738
Fill Area (SF)	4.803
Cut Vol (CF)	18.9
Fill Vol (CF)	10.3
Cum Cut Vol (CF)	11838.0
Cum Fill Vol (CF)	8250.4
Net Vol (CF)	3587.7

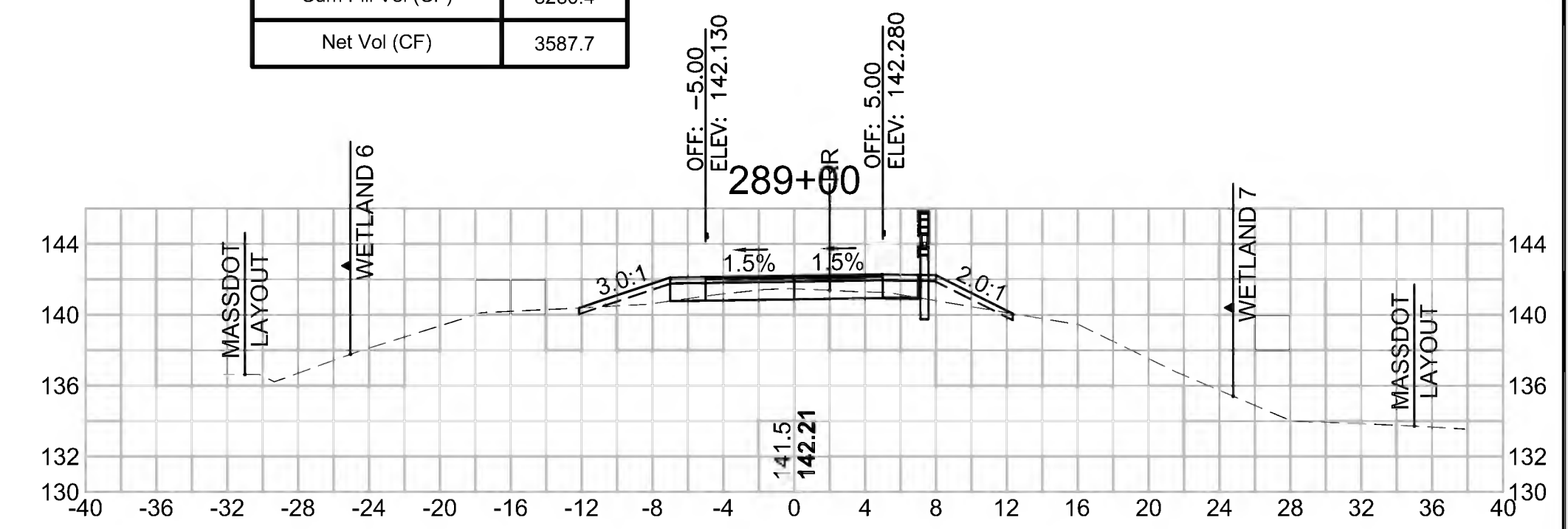

Total Volume at Station 285+50.00

Cut Area (SF)	19.066
Fill Area (SF)	3.194
Cut Vol (CF)	65.6
Fill Vol (CF)	8.5
Cum Cut Vol (CF)	11683.0
Cum Fill Vol (CF)	8193.9
Net Vol (CF)	3489.1

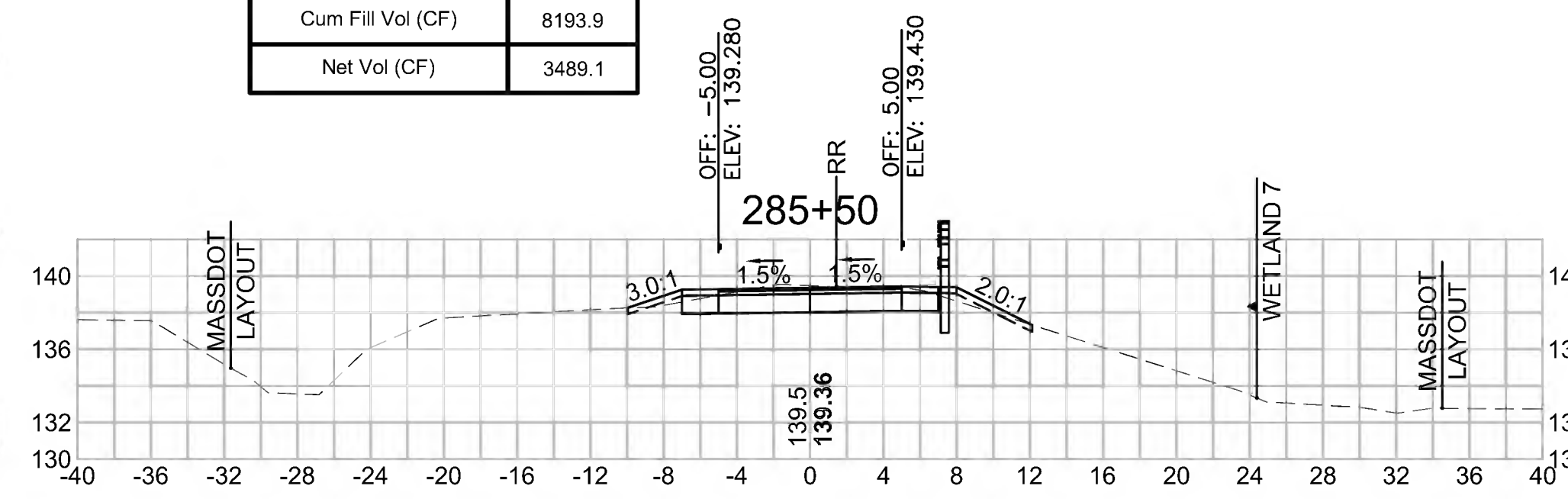

Total Volume at Station 287+00.00

Cut Area (SF)	8.206
Fill Area (SF)	3.343
Cut Vol (CF)	17.5
Fill Vol (CF)	5.4
Cum Cut Vol (CF)	11753.2
Cum Fill Vol (CF)	8207.4
Net Vol (CF)	3545.9

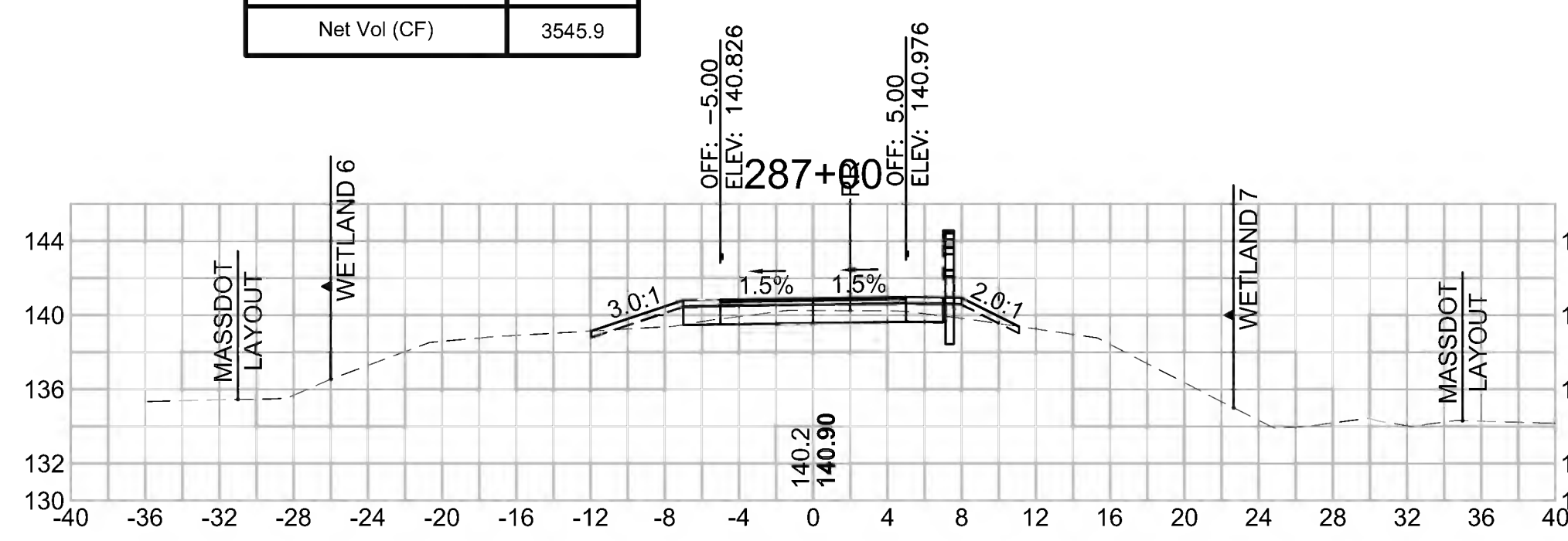

Total Volume at Station 288+50.00

Cut Area (SF)	14.651
Fill Area (SF)	6.327
Cut Vol (CF)	23.2
Fill Vol (CF)	11.7
Cum Cut Vol (CF)	11819.2
Cum Fill Vol (CF)	8240.1
Net Vol (CF)	3579.1

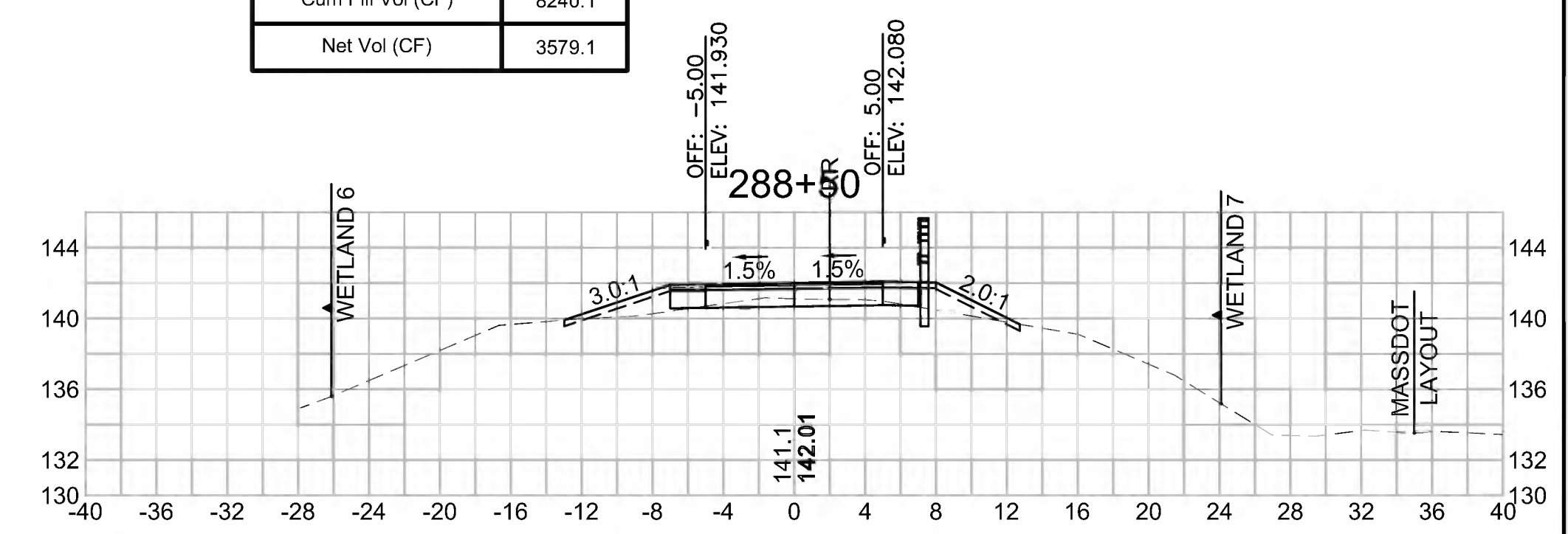

SUDBURY
BRUCE FREEMAN RAIL TRAIL

STATE	FED. AID PROJ. NO.	SHEET NO.	TOTAL SHEETS
MA	XXX-XXXX(XXX)X	290	319
PROJECT FILE NO. 608164			

CROSS SECTIONS

Total Volume at Station 291+00.00

Cut Area (SF)	13.191
Fill Area (SF)	1.057
Cut Vol (CF)	21.9
Fill Vol (CF)	2.3
Cum Cut Vol (CF)	11903.0
Cum Fill Vol (CF)	8277.7
Net Vol (CF)	3625.3

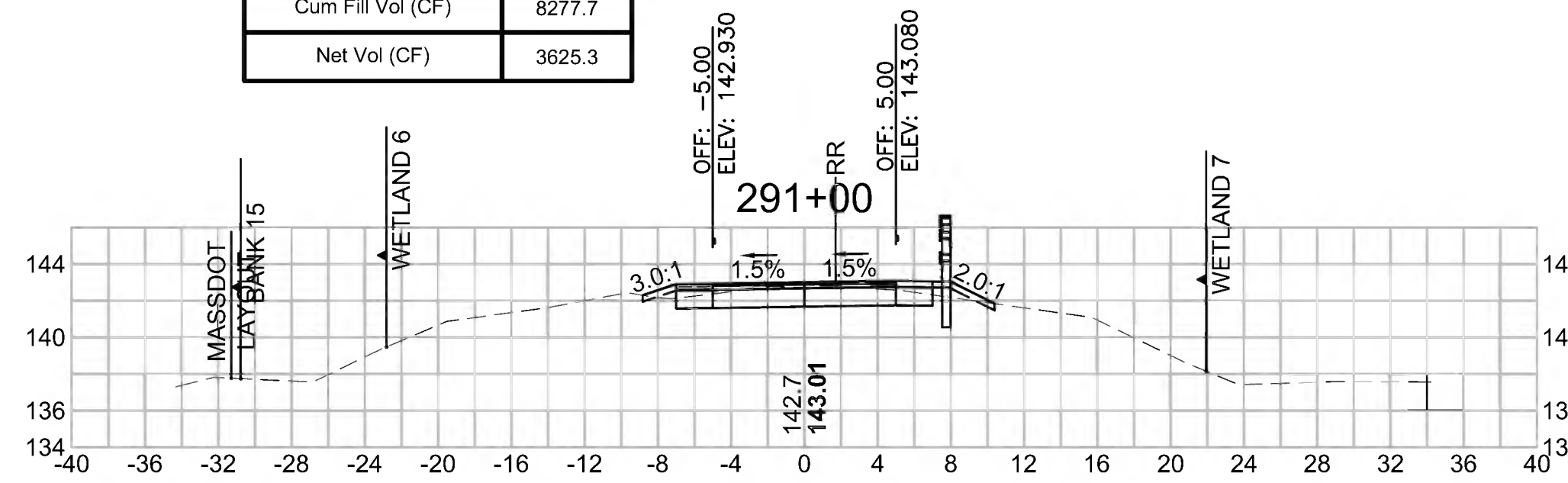

Total Volume at Station 292+50.00

Cut Area (SF)	16.886
Fill Area (SF)	0.000
Cut Vol (CF)	30.7
Fill Vol (CF)	0.0
Cum Cut Vol (CF)	11990.5
Cum Fill Vol (CF)	8278.7
Net Vol (CF)	3711.8

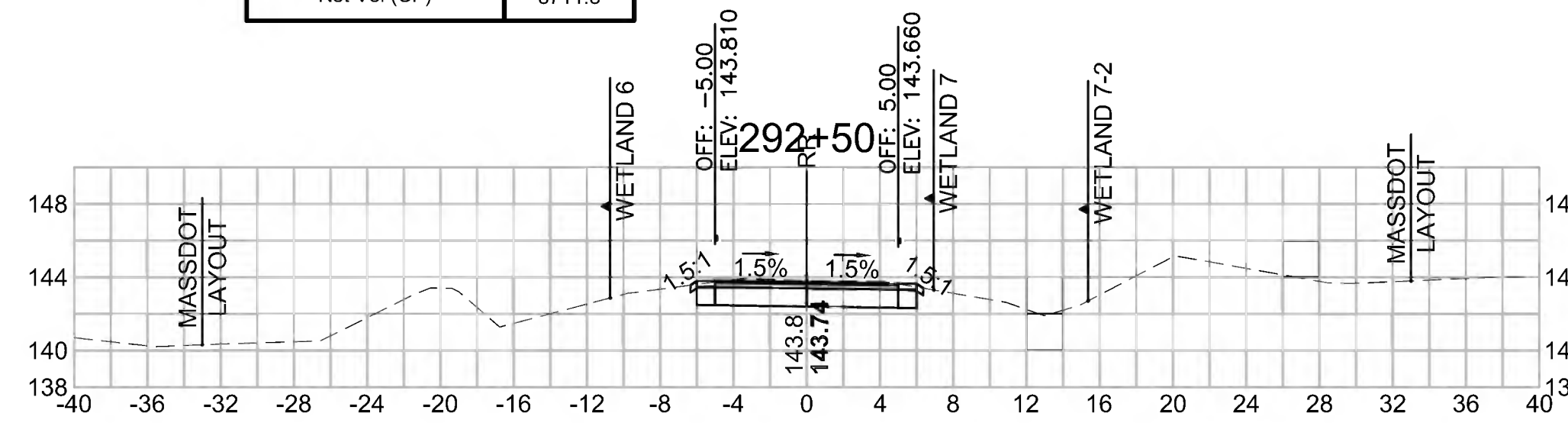

Total Volume at Station 294+00.00

Cut Area (SF)	19.091
Fill Area (SF)	0.000
Cut Vol (CF)	35.8
Fill Vol (CF)	0.0
Cum Cut Vol (CF)	12093.3
Cum Fill Vol (CF)	8278.7
Net Vol (CF)	3814.6

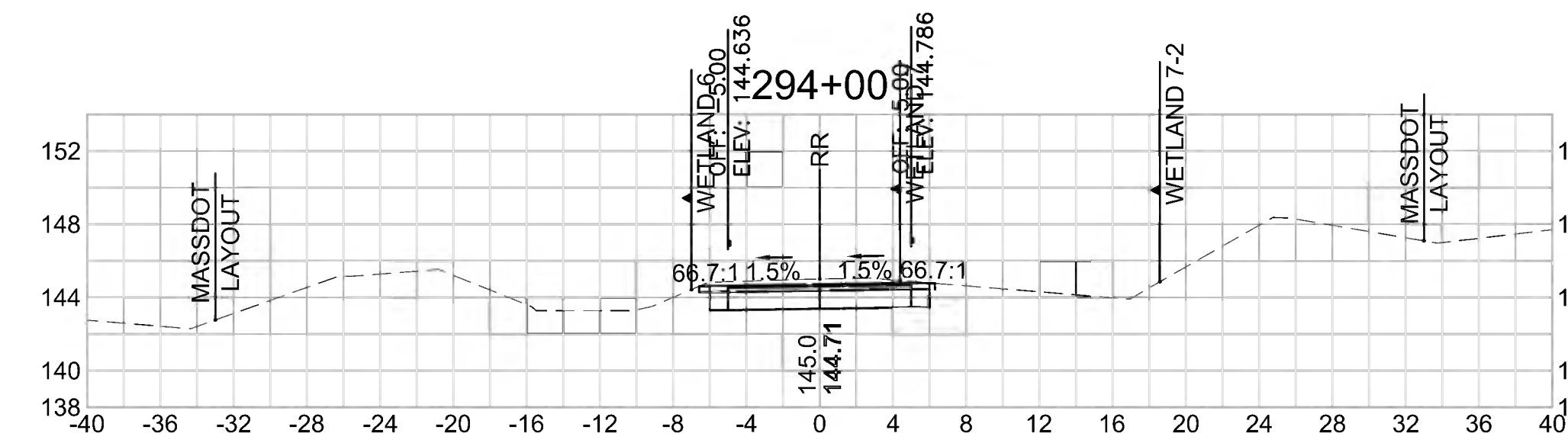

Total Volume at Station 290+50.00

Cut Area (SF)	10.501
Fill Area (SF)	1.398
Cut Vol (CF)	16.8
Fill Vol (CF)	7.9
Cum Cut Vol (CF)	11881.0
Cum Fill Vol (CF)	8275.4
Net Vol (CF)	3605.6

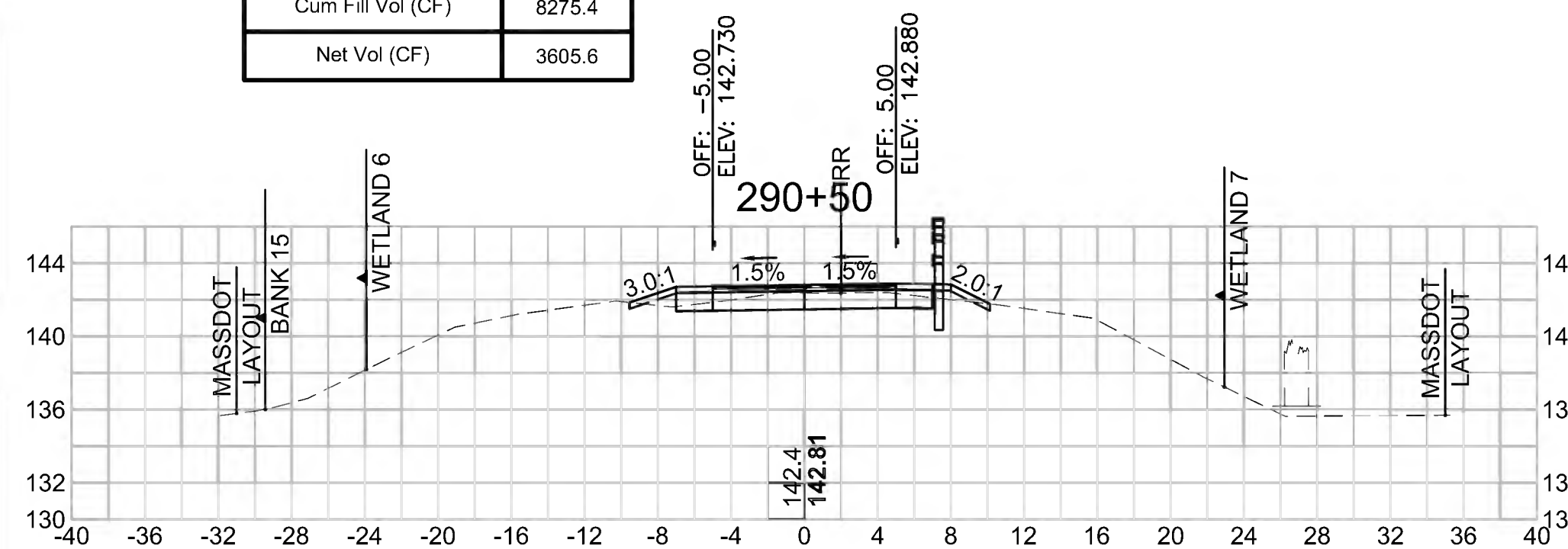

Total Volume at Station 292+00.00

Cut Area (SF)	16.290
Fill Area (SF)	0.024
Cut Vol (CF)	29.9
Fill Vol (CF)	0.0
Cum Cut Vol (CF)	11959.8
Cum Fill Vol (CF)	8278.7
Net Vol (CF)	3681.1

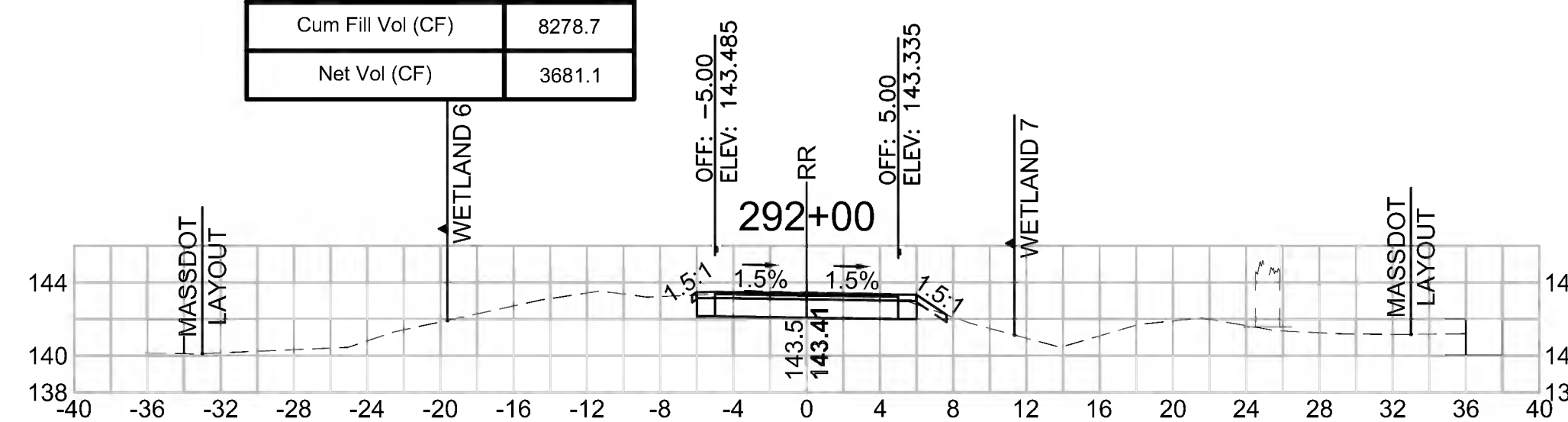

Total Volume at Station 293+50.00

Cut Area (SF)	19.542
Fill Area (SF)	0.000
Cut Vol (CF)	34.7
Fill Vol (CF)	0.0
Cum Cut Vol (CF)	12057.5
Cum Fill Vol (CF)	8278.7
Net Vol (CF)	3778.8

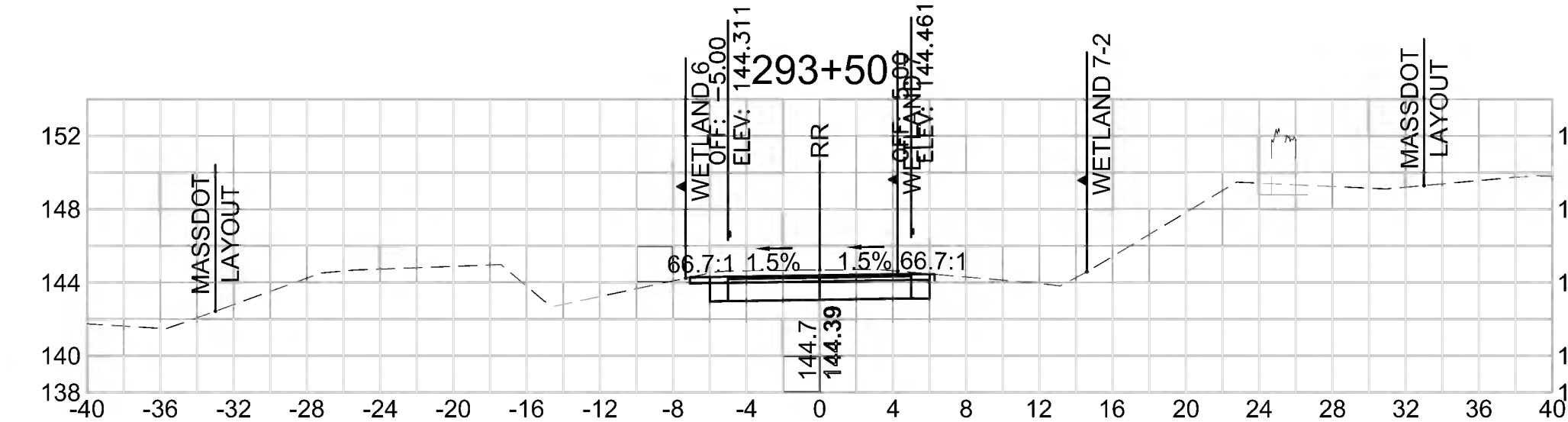

Total Volume at Station 290+00.00

Cut Area (SF)	7.605
Fill Area (SF)	7.084
Cut Vol (CF)	14.0
Fill Vol (CF)	9.7
Cum Cut Vol (CF)	11864.3
Cum Fill Vol (CF)	8267.6
Net Vol (CF)	3596.7

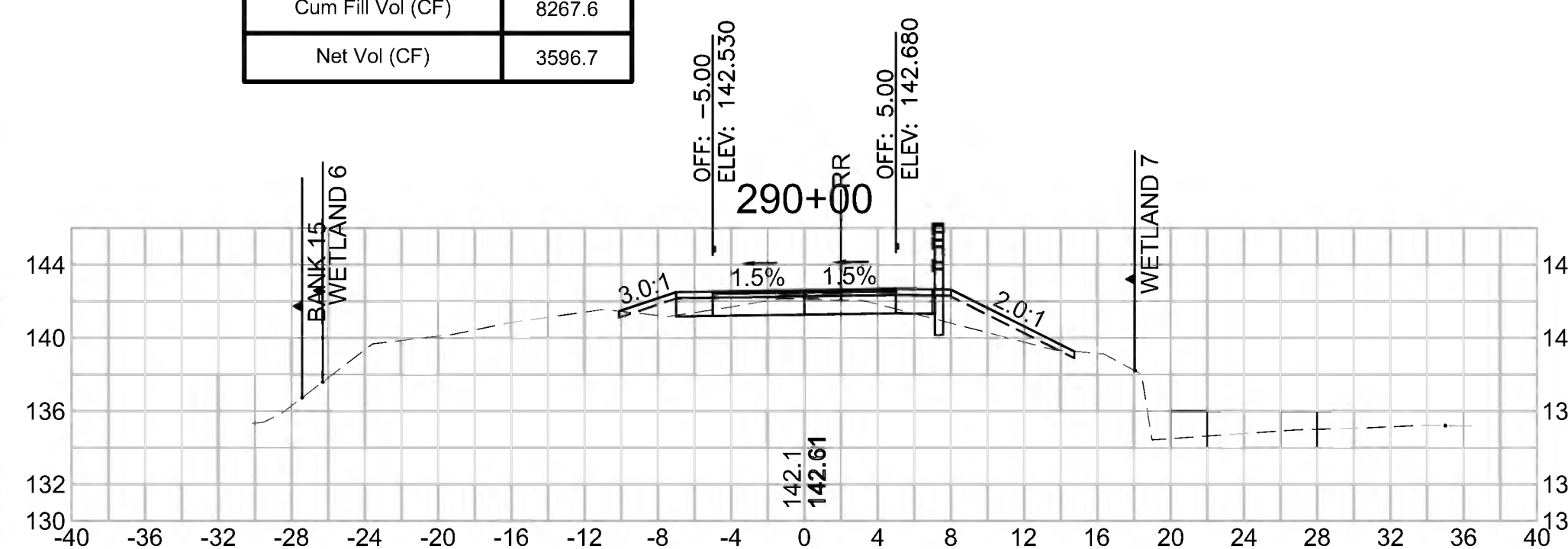

Total Volume at Station 291+50.00

Cut Area (SF)	15.952
Fill Area (SF)	0.001
Cut Vol (CF)	27.0
Fill Vol (CF)	1.0
Cum Cut Vol (CF)	11929.9
Cum Fill Vol (CF)	8278.7
Net Vol (CF)	3651.3

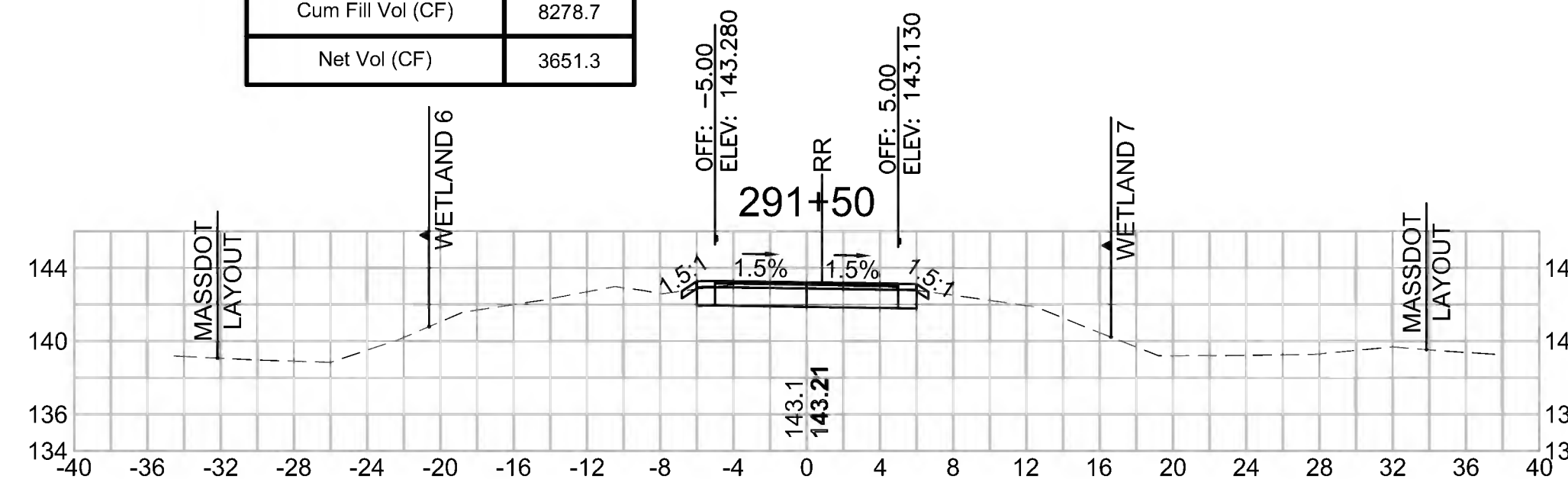

Total Volume at Station 293+00.00

Cut Area (SF)	17.971
Fill Area (SF)	0.000
Cut Vol (CF)	32.3
Fill Vol (CF)	0.0
Cum Cut Vol (CF)	12022.8
Cum Fill Vol (CF)	8278.7
Net Vol (CF)	3744.1

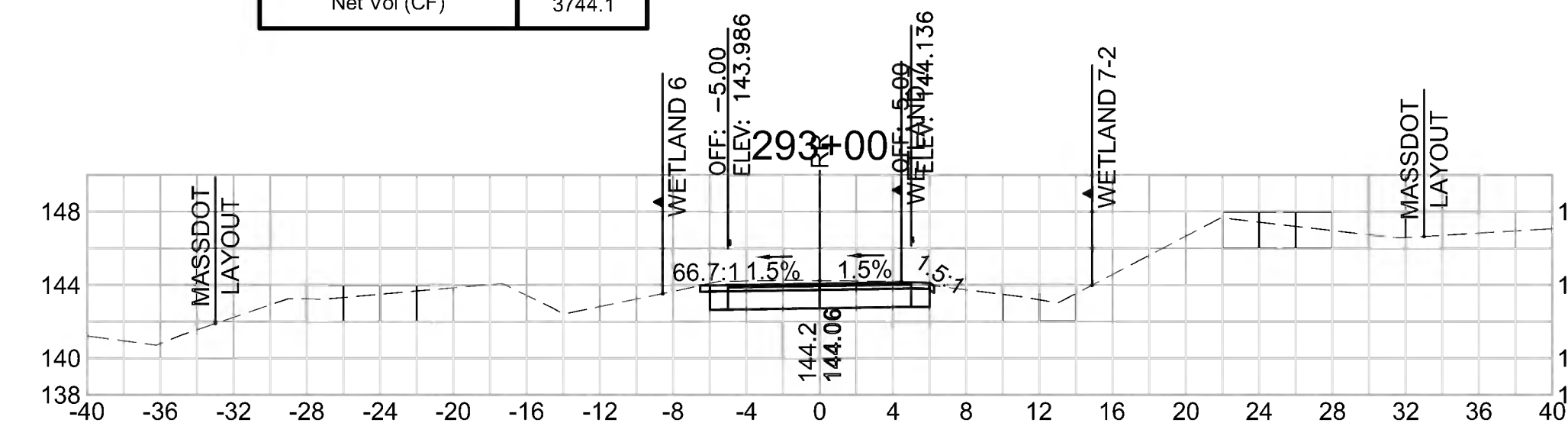

SUDBURY
BRUCE FREEMAN RAIL TRAIL

STATE	FED. AID PROJ. NO.	SHEET NO.	TOTAL SHEETS
MA	XXX-XXXX(XXX)X	291	319

PROJECT FILE NO. 608164

CROSS SECTIONS

Total Volume at Station 295+50.00

Cut Area (SF)	22.788
Fill Area (SF)	0.000
Cut Vol (CF)	41.1
Fill Vol (CF)	0.0
Cum Cut Vol (CF)	12210.4
Cum Fill Vol (CF)	8278.7
Net Vol (CF)	3931.6

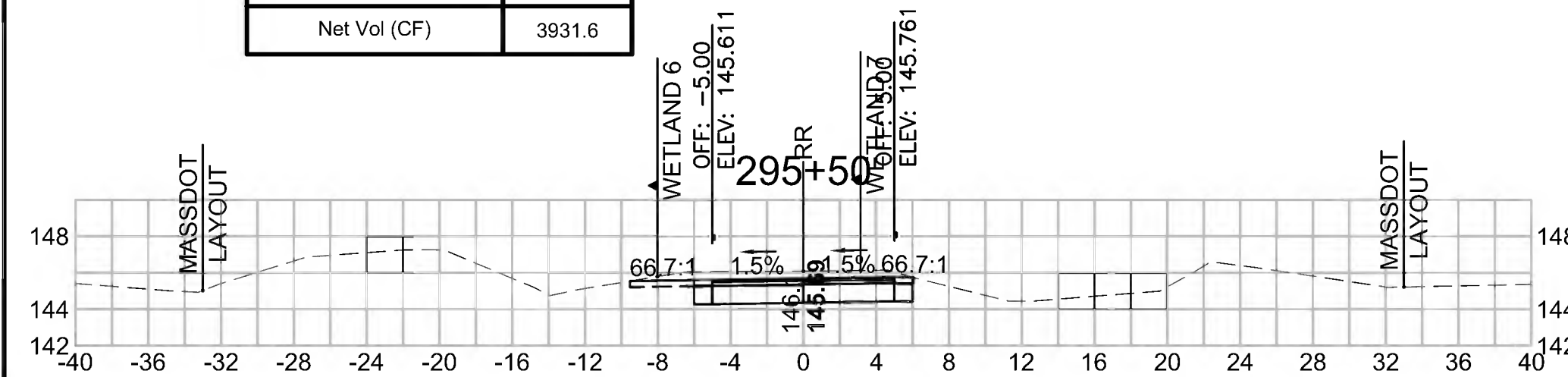

Total Volume at Station 297+00.00

Cut Area (SF)	22.246
Fill Area (SF)	0.000
Cut Vol (CF)	41.3
Fill Vol (CF)	0.0
Cum Cut Vol (CF)	12335.1
Cum Fill Vol (CF)	8278.7
Net Vol (CF)	4056.4

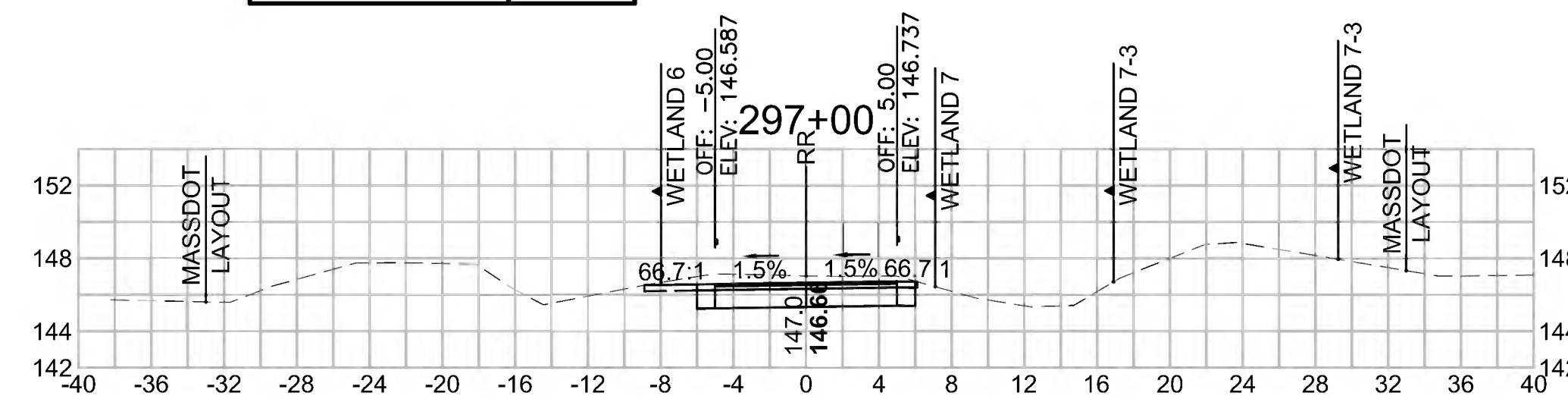

Total Volume at Station 298+50.00

Cut Area (SF)	20.555
Fill Area (SF)	0.000
Cut Vol (CF)	39.5
Fill Vol (CF)	0.0
Cum Cut Vol (CF)	12453.0
Cum Fill Vol (CF)	8278.7
Net Vol (CF)	4174.2

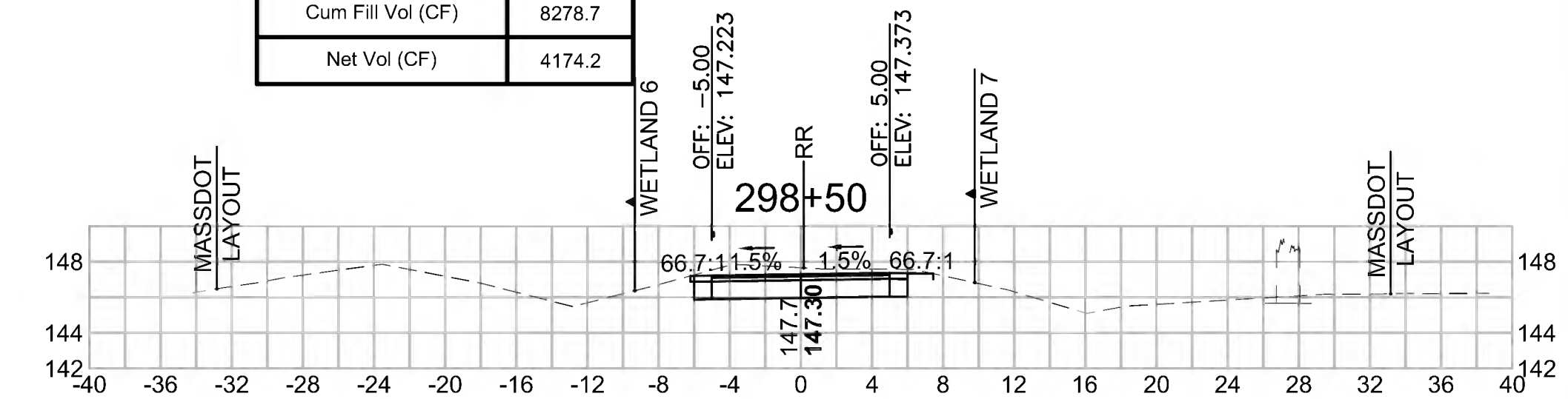

Total Volume at Station 295+00.00

Cut Area (SF)	21.649
Fill Area (SF)	0.000
Cut Vol (CF)	39.1
Fill Vol (CF)	0.0
Cum Cut Vol (CF)	12169.2
Cum Fill Vol (CF)	8278.7
Net Vol (CF)	3890.5

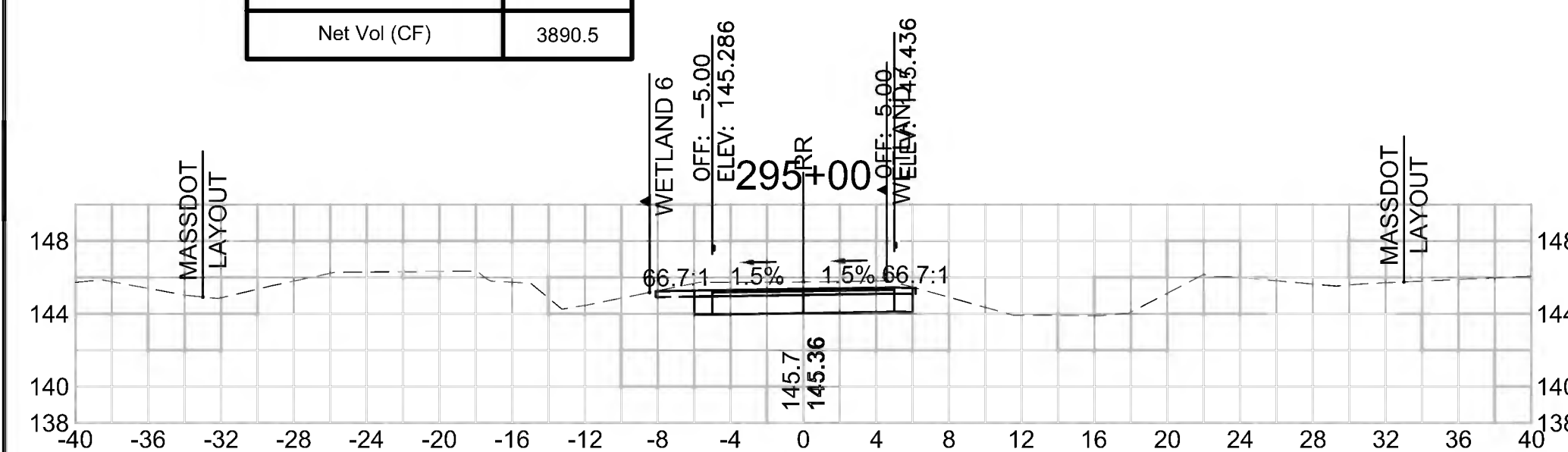

Total Volume at Station 296+50.00

Cut Area (SF)	22.352
Fill Area (SF)	0.000
Cut Vol (CF)	41.5
Fill Vol (CF)	0.0
Cum Cut Vol (CF)	12293.8
Cum Fill Vol (CF)	8278.7
Net Vol (CF)	4015.1

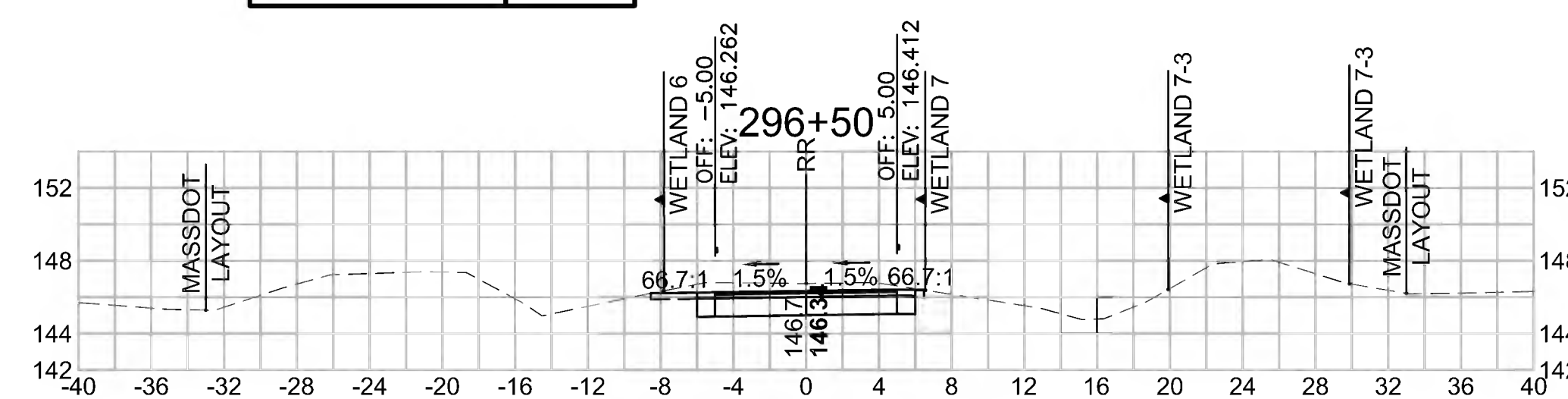

Total Volume at Station 298+00.00

Cut Area (SF)	22.100
Fill Area (SF)	0.000
Cut Vol (CF)	39.1
Fill Vol (CF)	0.0
Cum Cut Vol (CF)	12413.5
Cum Fill Vol (CF)	8278.7
Net Vol (CF)	4134.7

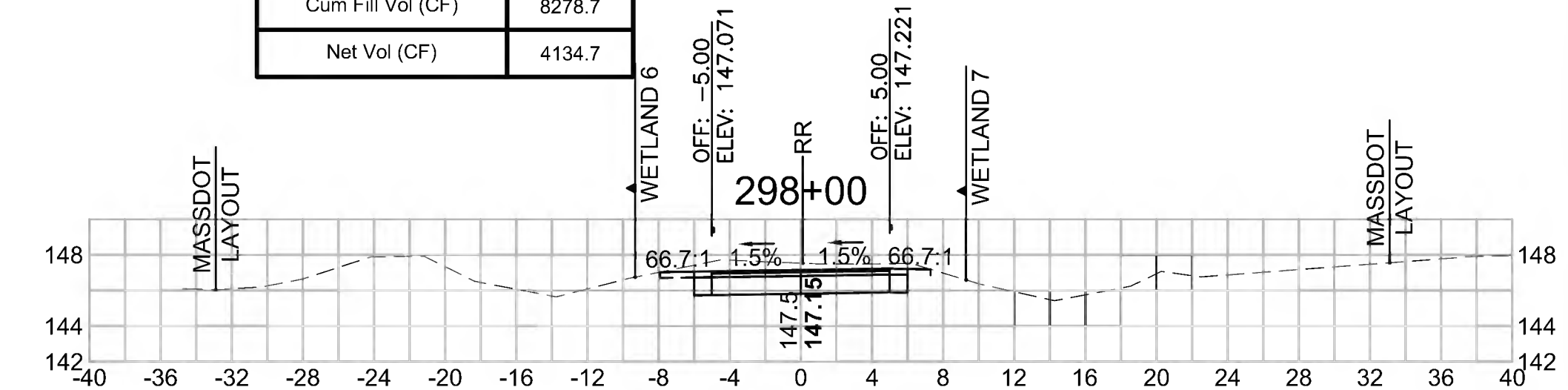

Total Volume at Station 294+50.00

Cut Area (SF)	20.627
Fill Area (SF)	0.000
Cut Vol (CF)	36.8
Fill Vol (CF)	0.0
Cum Cut Vol (CF)	12130.1
Cum Fill Vol (CF)	8278.7
Net Vol (CF)	3851.3

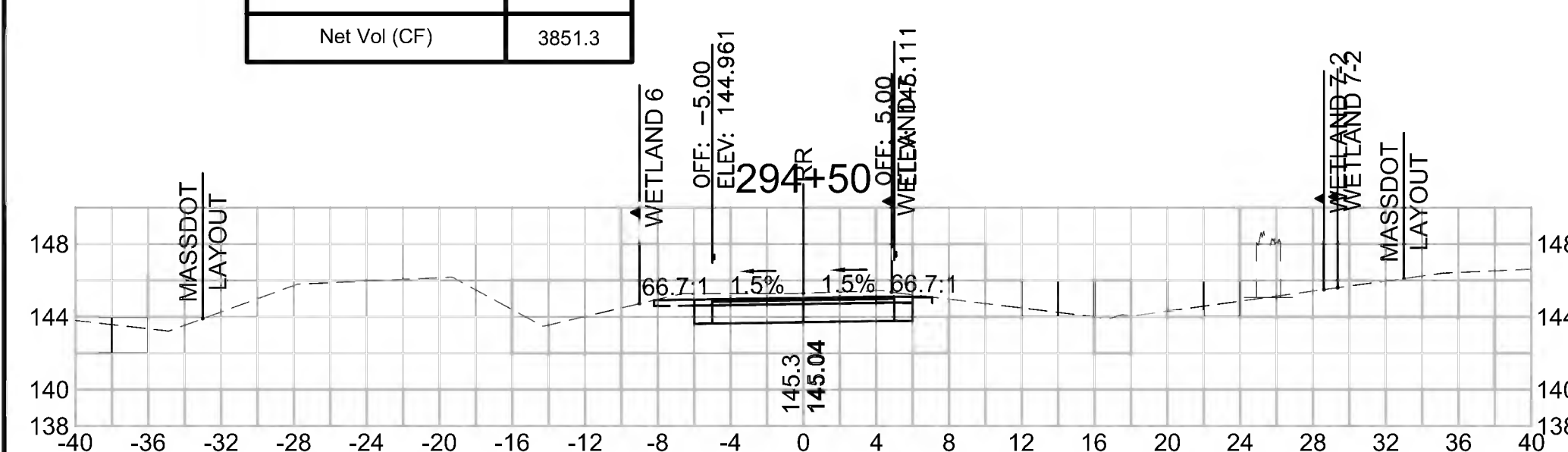

Total Volume at Station 296+00.00

Cut Area (SF)	22.498
Fill Area (SF)	0.000
Cut Vol (CF)	41.9
Fill Vol (CF)	0.0
Cum Cut Vol (CF)	12252.3
Cum Fill Vol (CF)	8278.7
Net Vol (CF)	3973.6

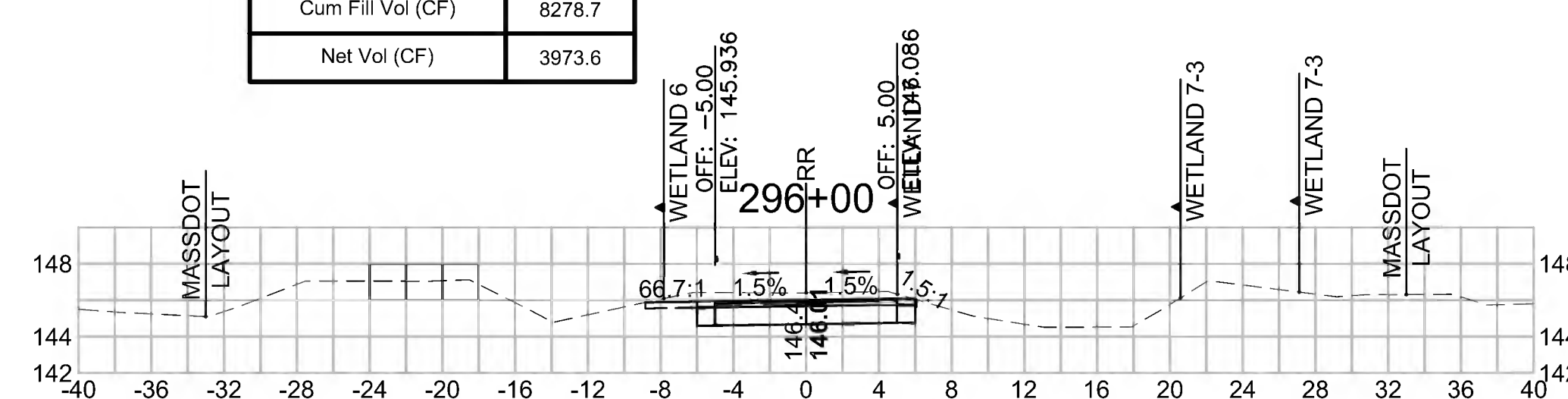

Total Volume at Station 297+50.00

Cut Area (SF)	20.129
Fill Area (SF)	0.000
Cut Vol (CF)	39.2
Fill Vol (CF)	0.0
Cum Cut Vol (CF)	12374.4
Cum Fill Vol (CF)	8278.7
Net Vol (CF)	4095.6

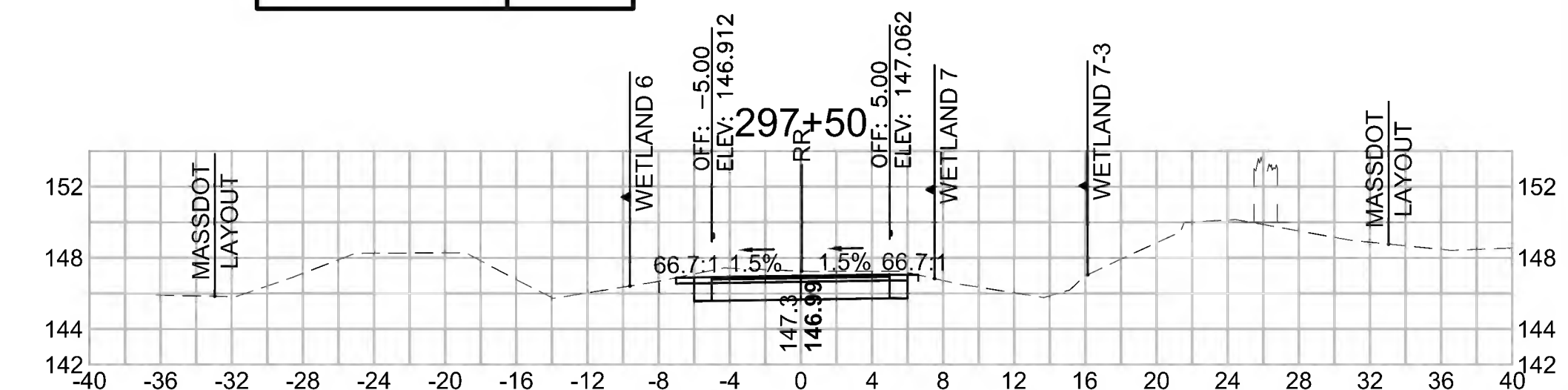

SUDBURY
BRUCE FREEMAN RAIL TRAIL

STATE	FED. AID PROJ. NO.	SHEET NO.	TOTAL SHEETS
MA	XXX-XXX(XXX)X	292	319

CROSS SECTIONS

Total Volume at Station 300+00.00

Cut Area (SF)	17.154
Fill Area (SF)	0.043
Cut Vol (CF)	32.7
Fill Vol (CF)	0.0
Cum Cut Vol (CF)	12557.0
Cum Fill Vol (CF)	8278.8
Net Vol (CF)	4278.2

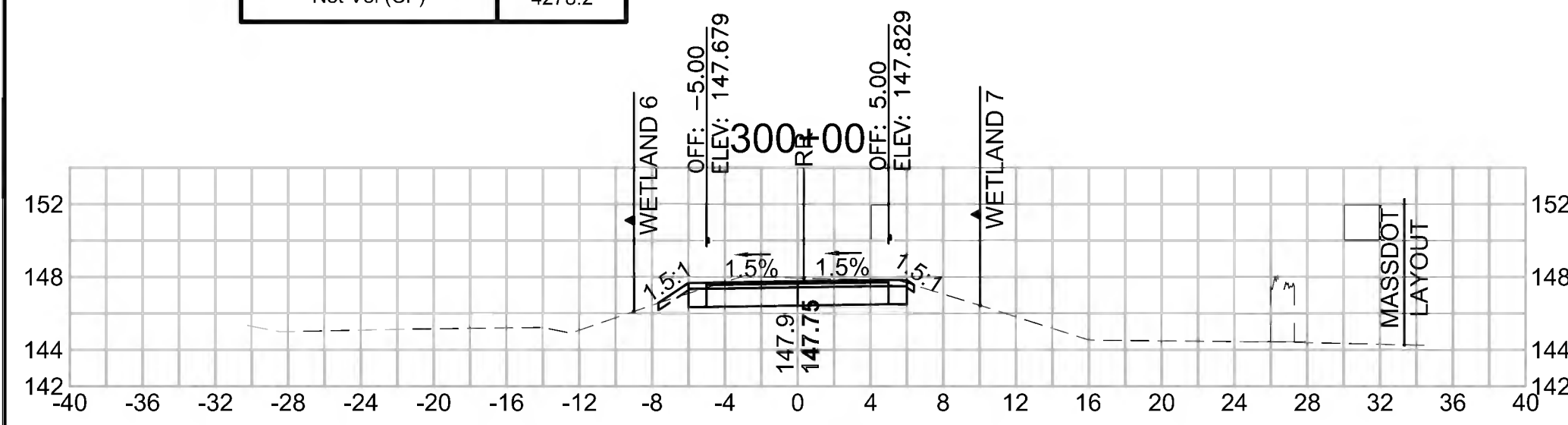

Total Volume at Station 301+50.00

Cut Area (SF)	16.144
Fill Area (SF)	0.556
Cut Vol (CF)	30.8
Fill Vol (CF)	0.6
Cum Cut Vol (CF)	12651.0
Cum Fill Vol (CF)	8279.6
Net Vol (CF)	4371.4

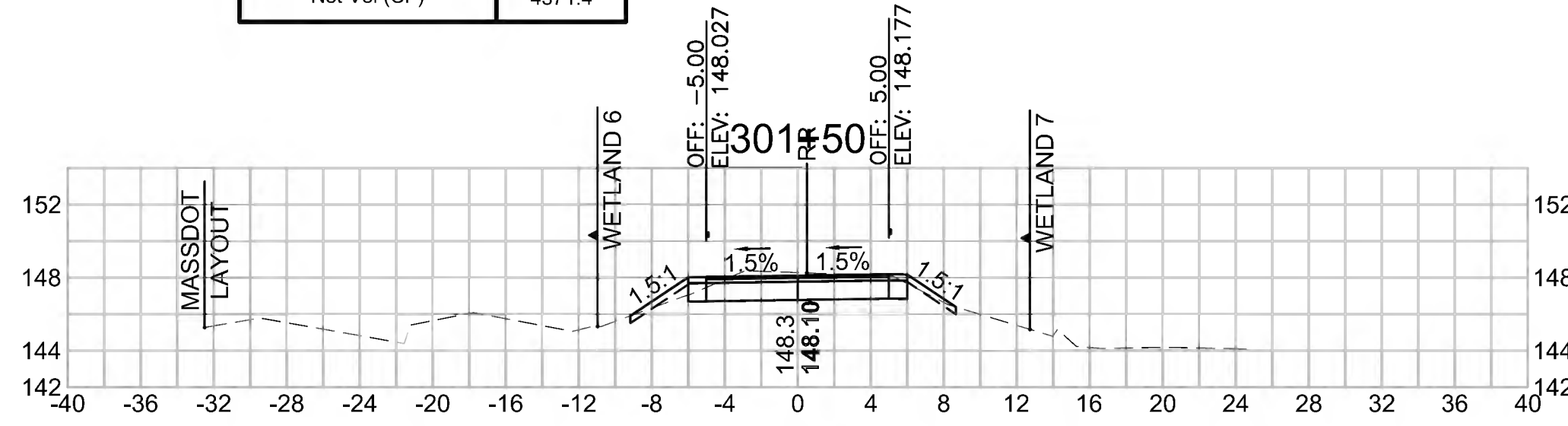

Total Volume at Station 303+00.00

Cut Area (SF)	14.693
Fill Area (SF)	0.053
Cut Vol (CF)	28.2
Fill Vol (CF)	0.1
Cum Cut Vol (CF)	12739.4
Cum Fill Vol (CF)	8280.4
Net Vol (CF)	4459.0

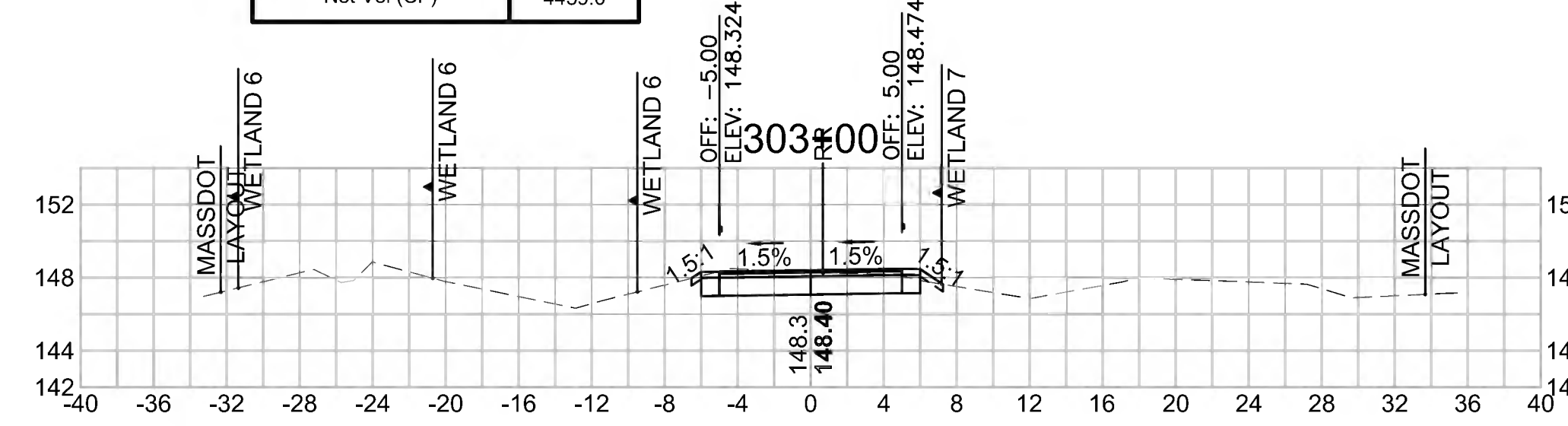

Total Volume at Station 299+50.00

Cut Area (SF)	18.190
Fill Area (SF)	0.000
Cut Vol (CF)	34.6
Fill Vol (CF)	0.0
Cum Cut Vol (CF)	12524.3
Cum Fill Vol (CF)	8278.7
Net Vol (CF)	4245.5

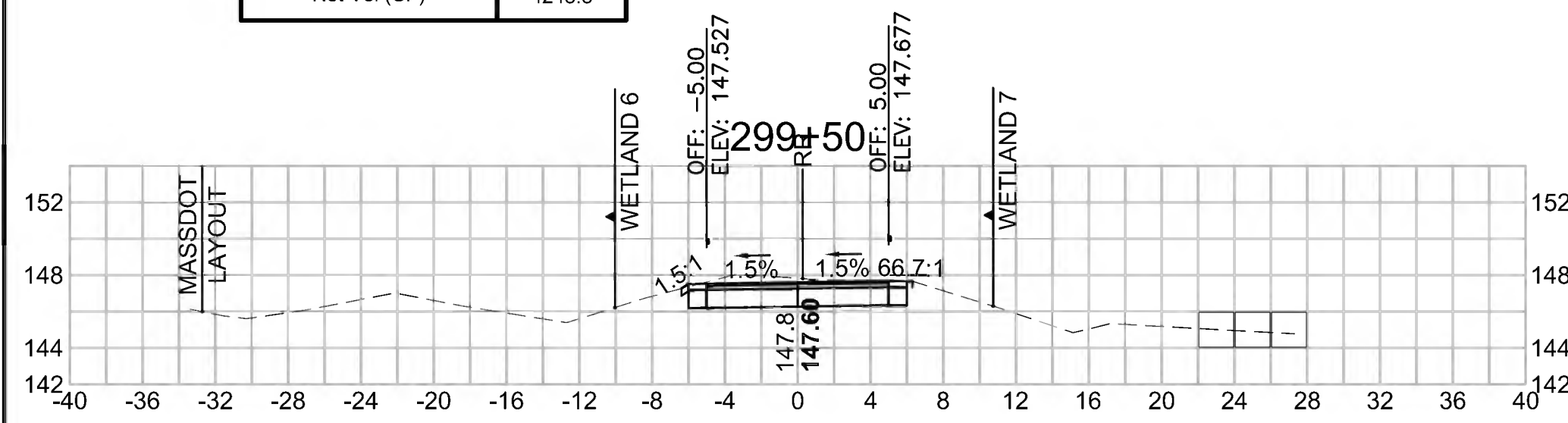

Total Volume at Station 301+00.00

Cut Area (SF)	17.105
Fill Area (SF)	0.042
Cut Vol (CF)	31.6
Fill Vol (CF)	0.1
Cum Cut Vol (CF)	12620.2
Cum Fill Vol (CF)	8279.0
Net Vol (CF)	4341.2

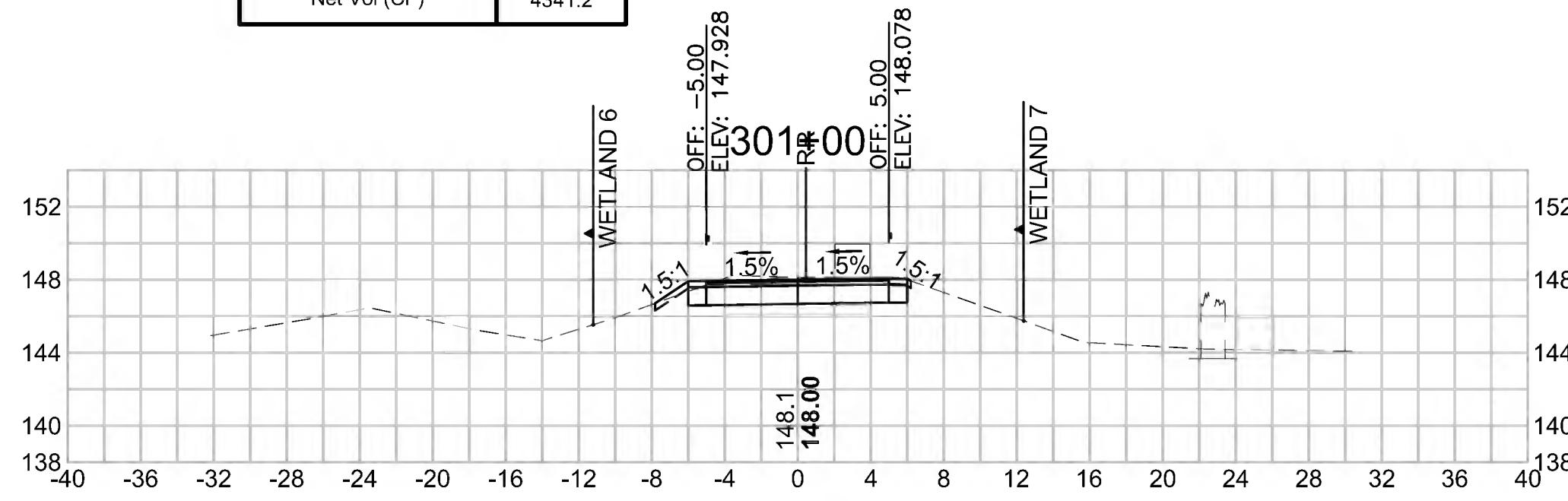

Total Volume at Station 302+50.00

Cut Area (SF)	15.798
Fill Area (SF)	0.017
Cut Vol (CF)	29.9
Fill Vol (CF)	0.1
Cum Cut Vol (CF)	12711.2
Cum Fill Vol (CF)	8280.3
Net Vol (CF)	4430.9

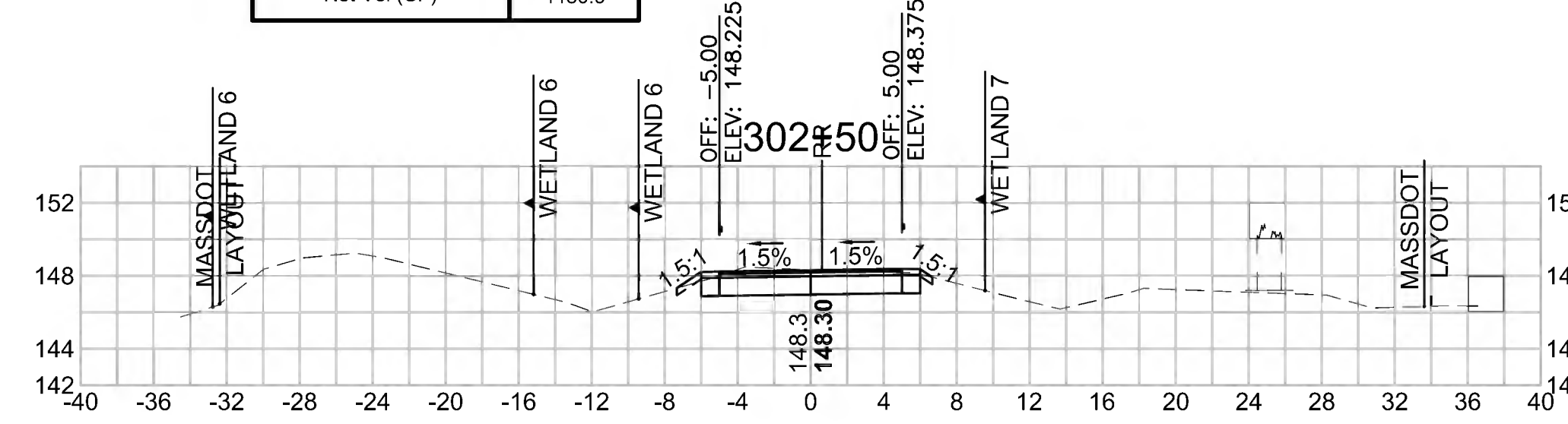

Total Volume at Station 299+00.00

Cut Area (SF)	19.134
Fill Area (SF)	0.000
Cut Vol (CF)	36.7
Fill Vol (CF)	0.0
Cum Cut Vol (CF)	12489.7
Cum Fill Vol (CF)	8278.7
Net Vol (CF)	4211.0

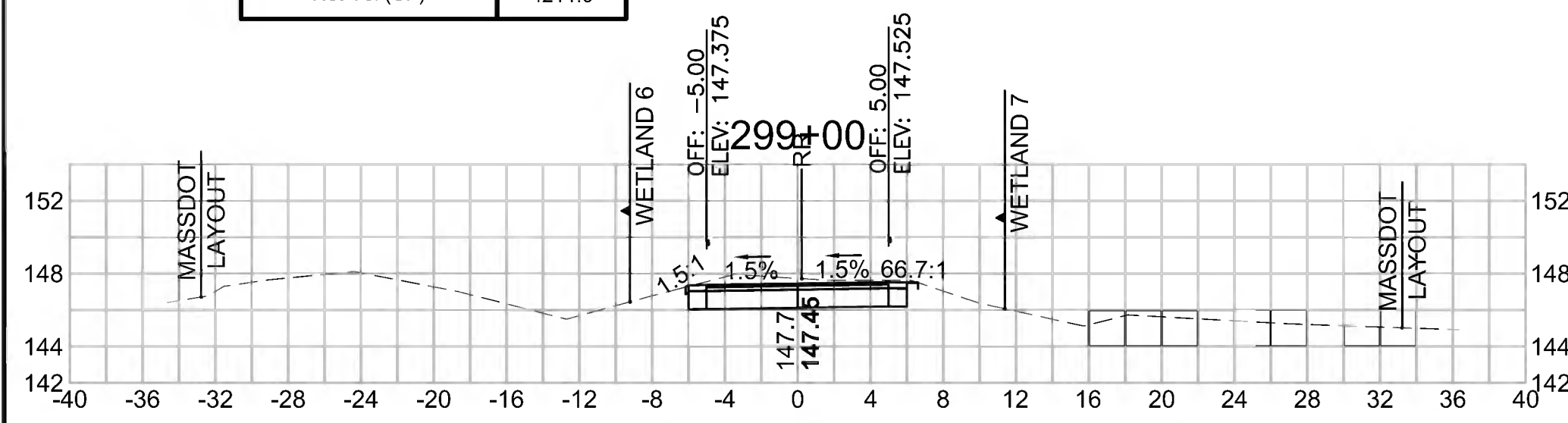

Total Volume at Station 300+50.00

Cut Area (SF)	17.029
Fill Area (SF)	0.093
Cut Vol (CF)	31.7
Fill Vol (CF)	0.1
Cum Cut Vol (CF)	12588.6
Cum Fill Vol (CF)	8278.9
Net Vol (CF)	4309.7

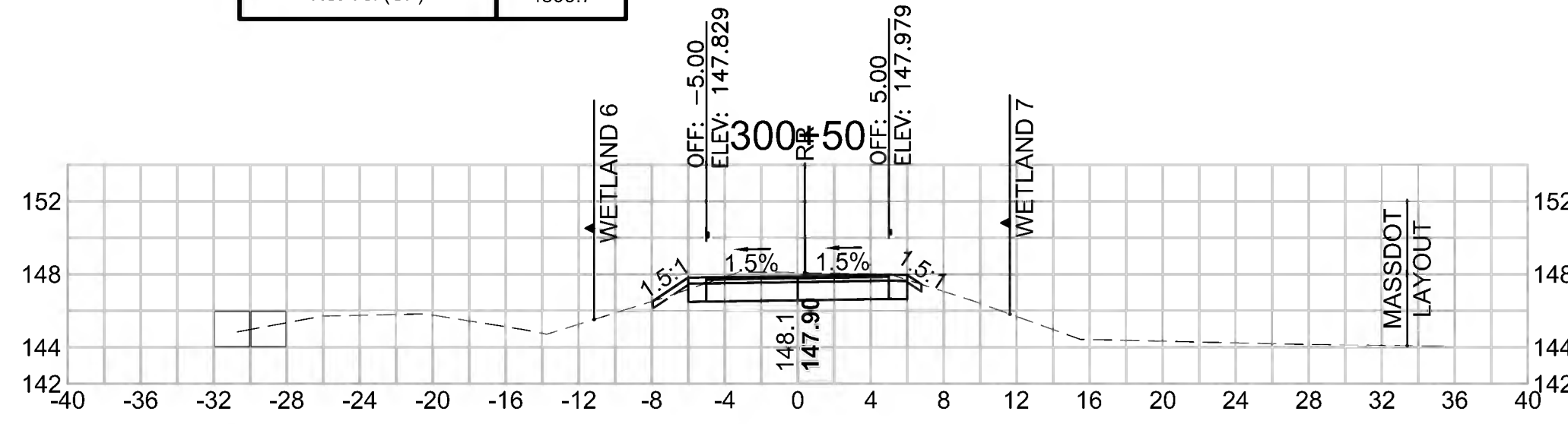

Total Volume at Station 302+00.00

Cut Area (SF)	16.496
Fill Area (SF)	0.094
Cut Vol (CF)	30.2
Fill Vol (CF)	0.6
Cum Cut Vol (CF)	12681.3
Cum Fill Vol (CF)	8280.2
Net Vol (CF)	4401.1

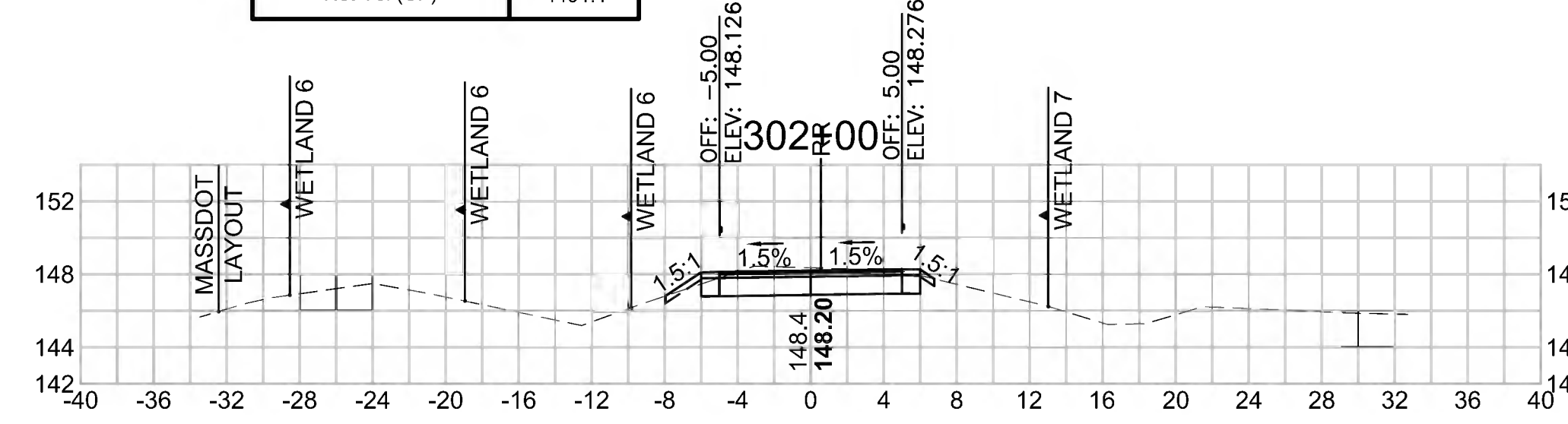

SUDBURY
BRUCE FREEMAN RAIL TRAIL

STATE	FED. AID PROJ. NO.	SHEET NO.	TOTAL SHEETS
MA	XXX-XXXX(XXX)X	293	319

PROJECT FILE NO. 608164

CROSS SECTIONS

608164_XSEC(CROSS SECTION LAYOUTS).DWG 18-Feb-2022

Total Volume at Station 304+50.00

Cut Area (SF)	12.695
Fill Area (SF)	0.527
Cut Vol (CF)	22.7
Fill Vol (CF)	0.5
Cum Cut Vol (CF)	12810.9
Cum Fill Vol (CF)	8281.0
Net Vol (CF)	4529.9

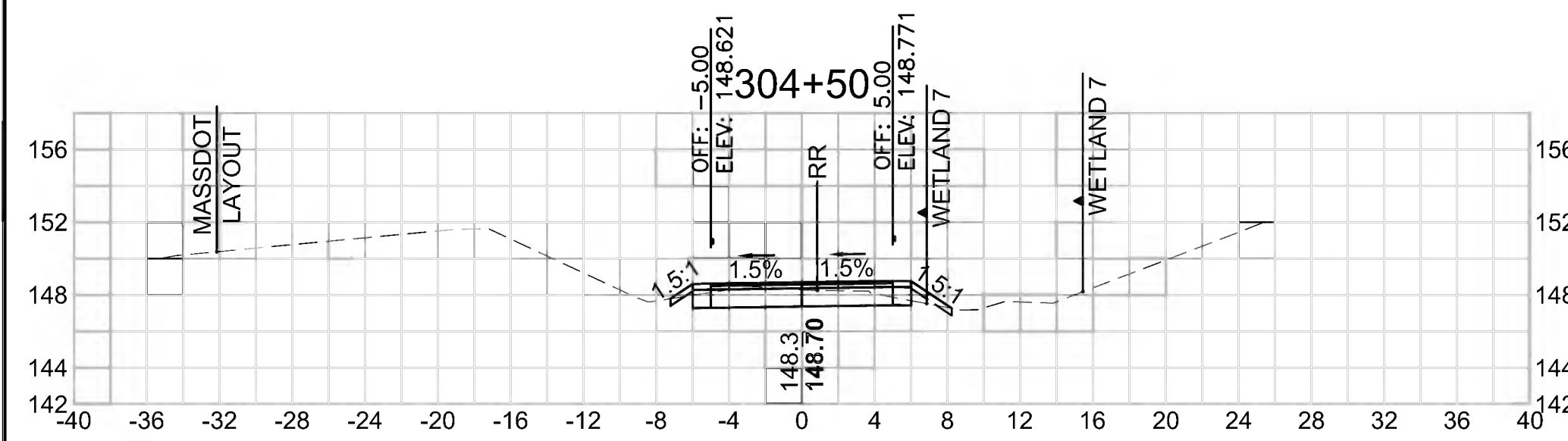

Total Volume at Station 306+00.00

Cut Area (SF)	18.518
Fill Area (SF)	4.761
Cut Vol (CF)	41.9
Fill Vol (CF)	8.9
Cum Cut Vol (CF)	12927.5
Cum Fill Vol (CF)	8295.4
Net Vol (CF)	4632.1

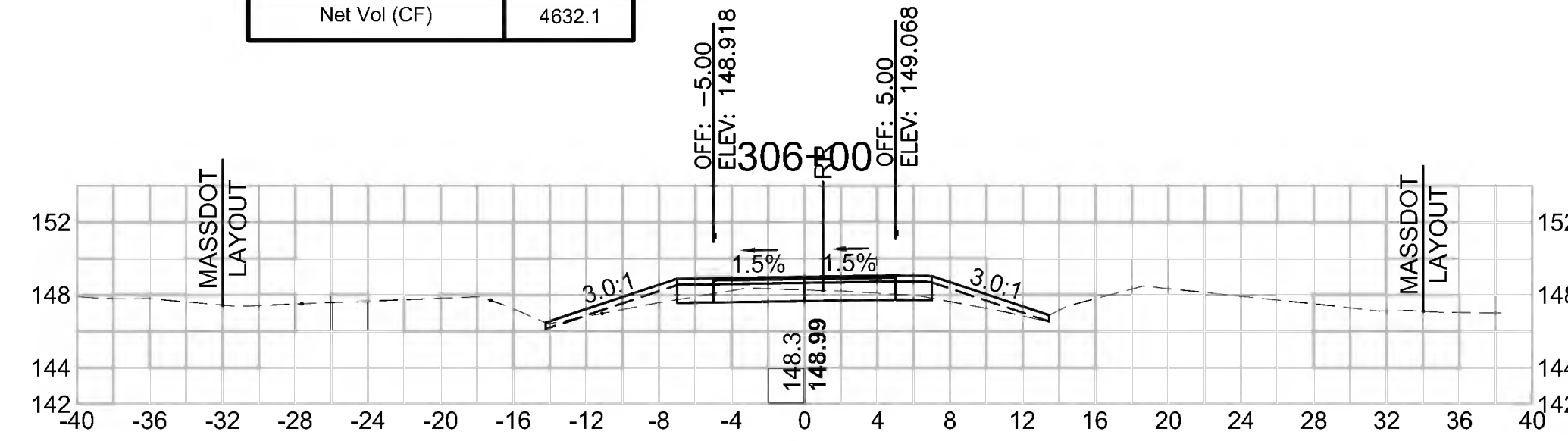

Total Volume at Station 307+50.00

Cut Area (SF)	79.732
Fill Area (SF)	0.024
Cut Vol (CF)	101.4
Fill Vol (CF)	12.3
Cum Cut Vol (CF)	13098.9
Cum Fill Vol (CF)	8334.0
Net Vol (CF)	4764.9

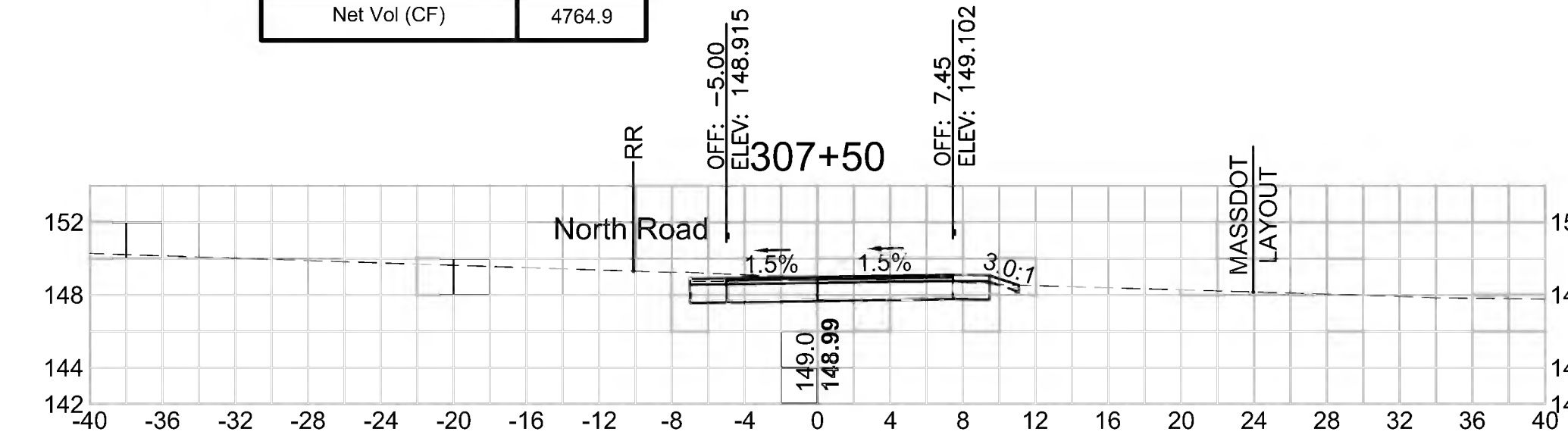

Total Volume at Station 304+00.00

Cut Area (SF)	11.791
Fill Area (SF)	0.064
Cut Vol (CF)	23.1
Fill Vol (CF)	0.1
Cum Cut Vol (CF)	12788.3
Cum Fill Vol (CF)	8280.5
Net Vol (CF)	4507.8

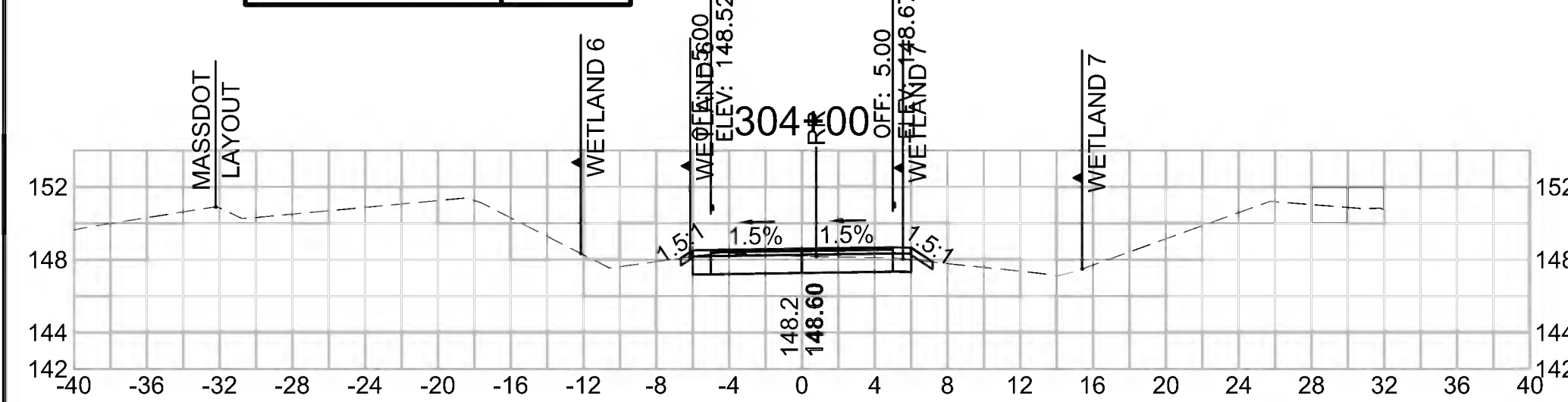

Total Volume at Station 305+50.00

Cut Area (SF)	26.728
Fill Area (SF)	4.848
Cut Vol (CF)	43.8
Fill Vol (CF)	4.7
Cum Cut Vol (CF)	12885.6
Cum Fill Vol (CF)	8286.5
Net Vol (CF)	4599.1

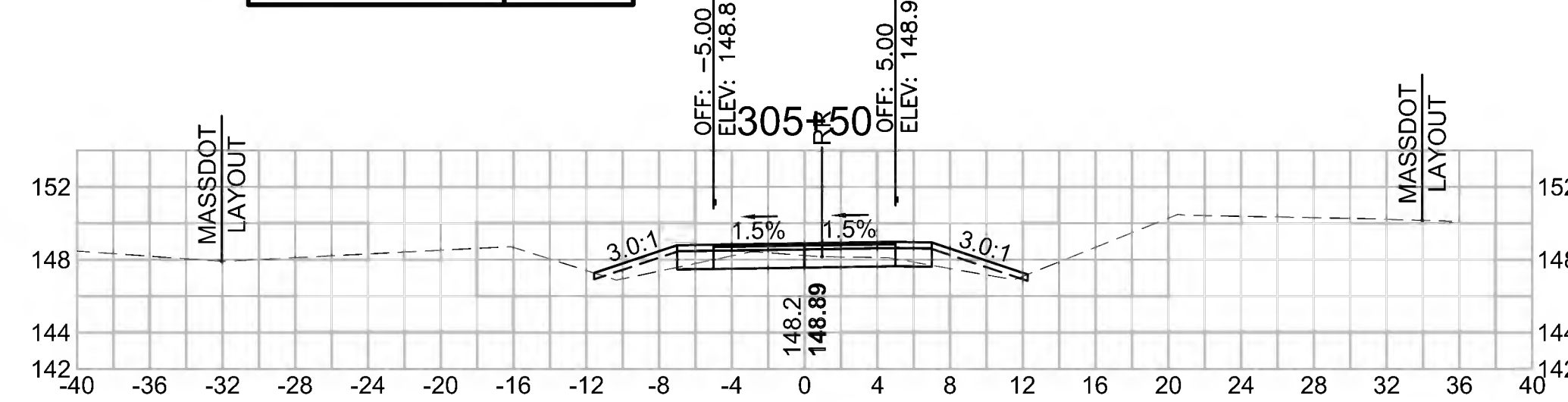

Total Volume at Station 307+00.00

Cut Area (SF)	29.756
Fill Area (SF)	13.211
Cut Vol (CF)	40.2
Fill Vol (CF)	17.1
Cum Cut Vol (CF)	12997.5
Cum Fill Vol (CF)	8321.7
Net Vol (CF)	4675.7

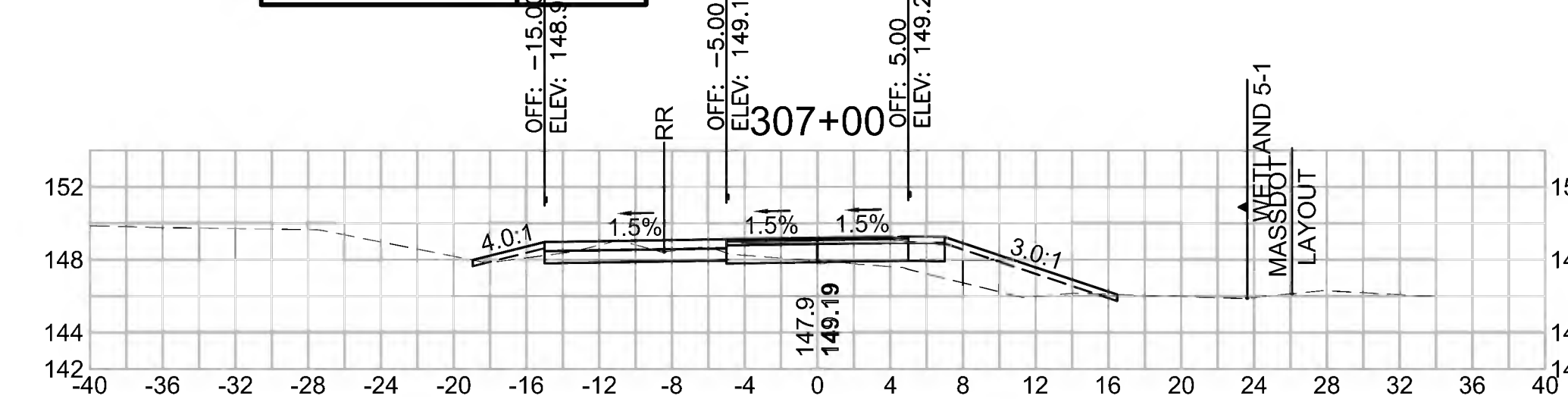

Total Volume at Station 303+50.00

Cut Area (SF)	13.145
Fill Area (SF)	0.011
Cut Vol (CF)	25.8
Fill Vol (CF)	0.1
Cum Cut Vol (CF)	12765.2
Cum Fill Vol (CF)	8280.4
Net Vol (CF)	4484.8

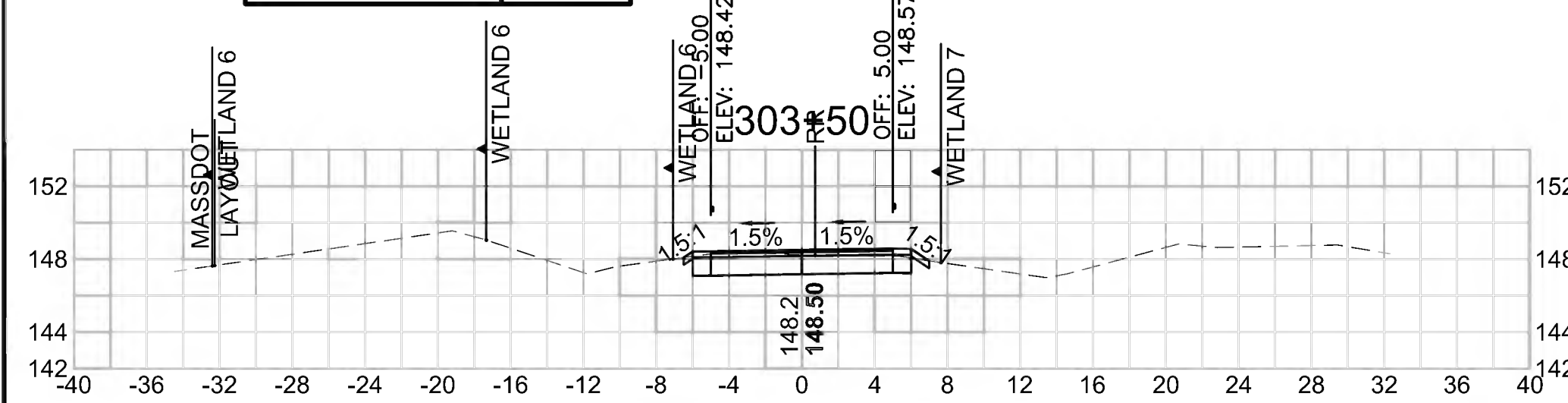

Total Volume at Station 305+00.00

Cut Area (SF)	20.597
Fill Area (SF)	0.254
Cut Vol (CF)	30.8
Fill Vol (CF)	0.7
Cum Cut Vol (CF)	12841.7
Cum Fill Vol (CF)	8281.8
Net Vol (CF)	4560.0

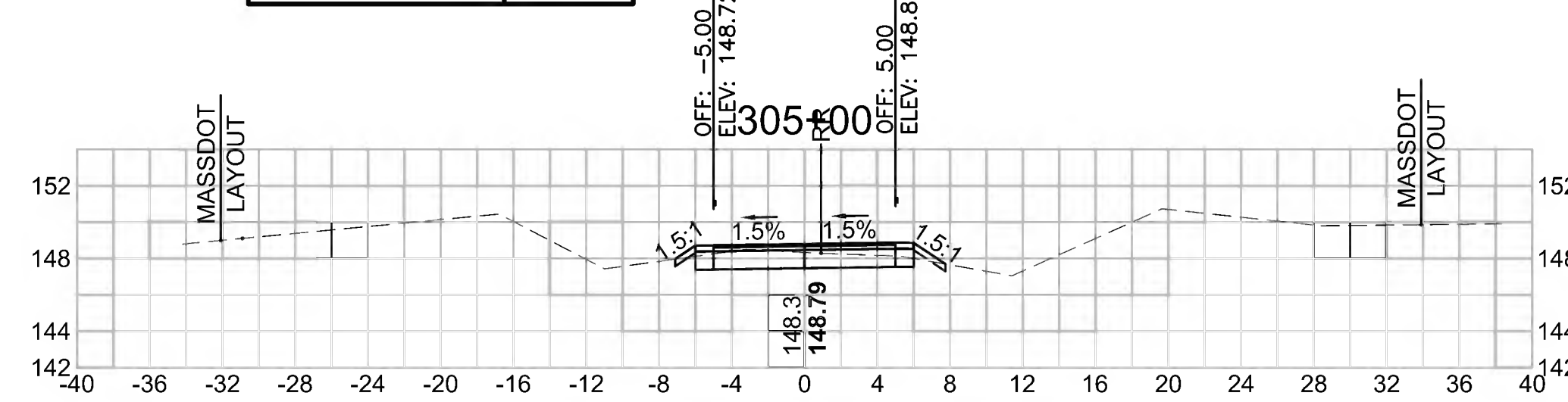

Total Volume at Station 306+50.00

Cut Area (SF)	13.675
Fill Area (SF)	5.256
Cut Vol (CF)	29.8
Fill Vol (CF)	9.3
Cum Cut Vol (CF)	12957.3
Cum Fill Vol (CF)	8304.6
Net Vol (CF)	4652.6

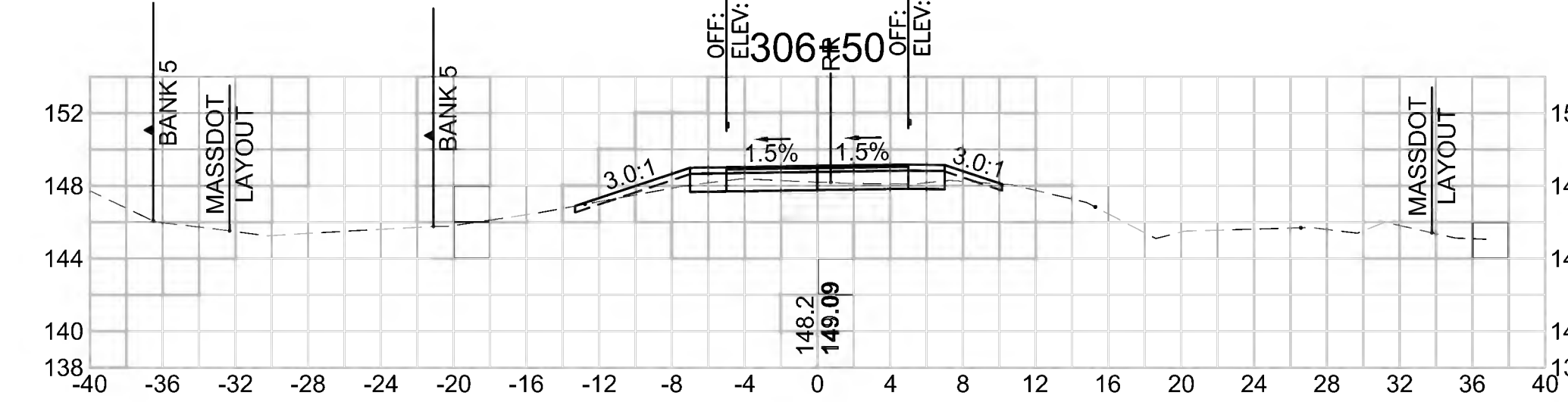

SUDBURY
BRUCE FREEMAN RAIL TRAIL

STATE	FED. AID PROJ. NO.	SHEET NO.	TOTAL SHEETS
MA	XXX-XXXX(XXX)X	294	319
PROJECT FILE NO. 608164			

CROSS SECTIONS

Total Volume at Station 309+00.00	
Cut Area (SF)	28.856
Fill Area (SF)	1.518
Cut Vol (CF)	50.9
Fill Vol (CF)	1.5
Cum Cut Vol (CF)	13281.6
Cum Fill Vol (CF)	8365.4
Net Vol (CF)	4916.2

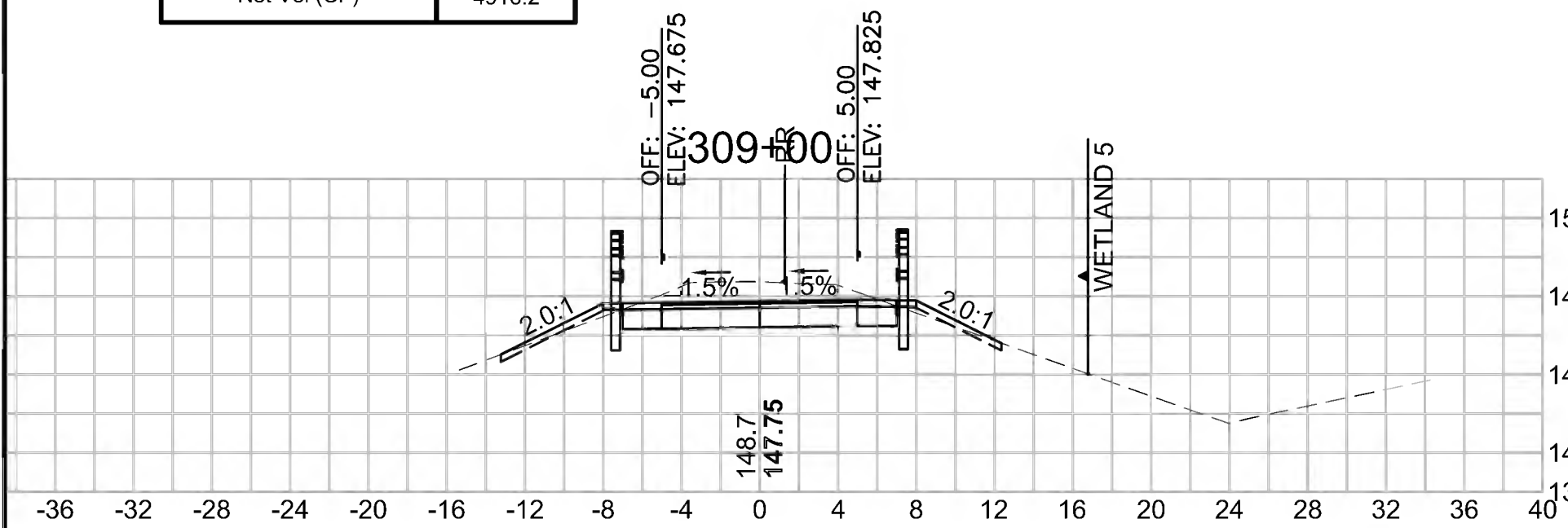

Total Volume at Station 310+50.00	
Cut Area (SF)	47.202
Fill Area (SF)	0.000
Cut Vol (CF)	87.8
Fill Vol (CF)	0.0
Cum Cut Vol (CF)	13516.5
Cum Fill Vol (CF)	8377.3
Net Vol (CF)	5139.3

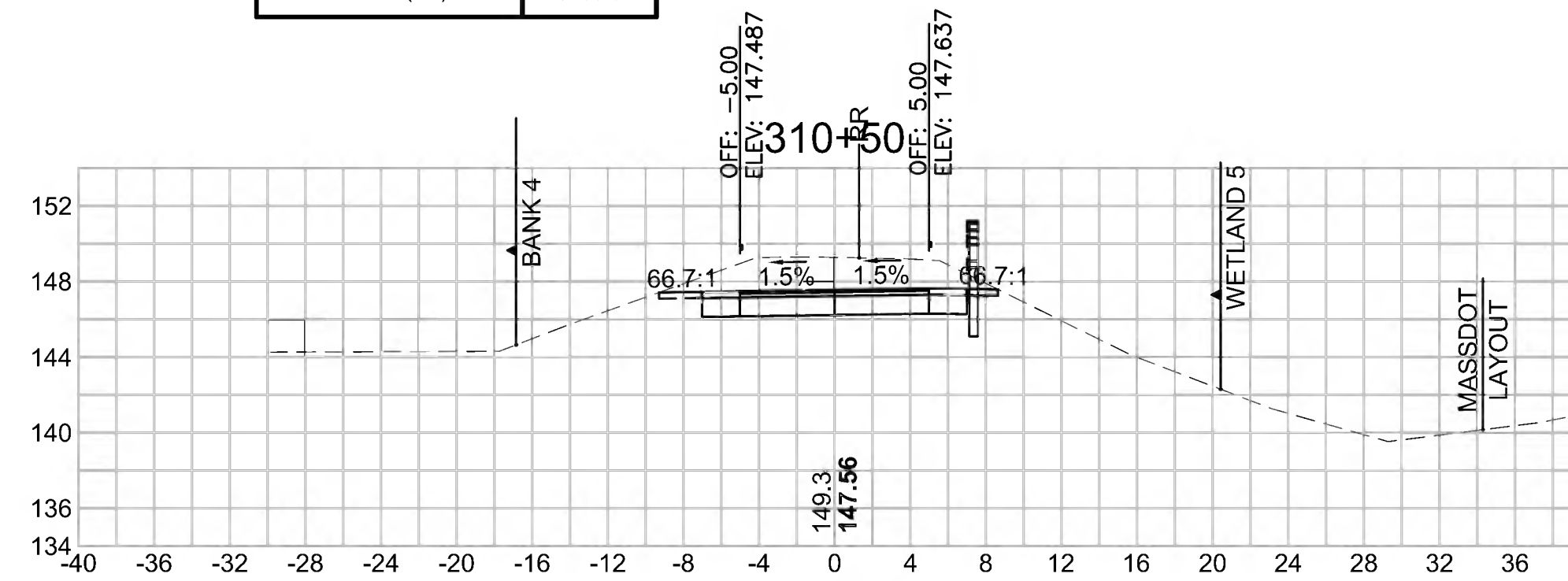

Total Volume at Station 312+00.00	
Cut Area (SF)	59.214
Fill Area (SF)	0.123
Cut Vol (CF)	118.2
Fill Vol (CF)	0.1
Cum Cut Vol (CF)	13856.2
Cum Fill Vol (CF)	8377.7
Net Vol (CF)	5478.5

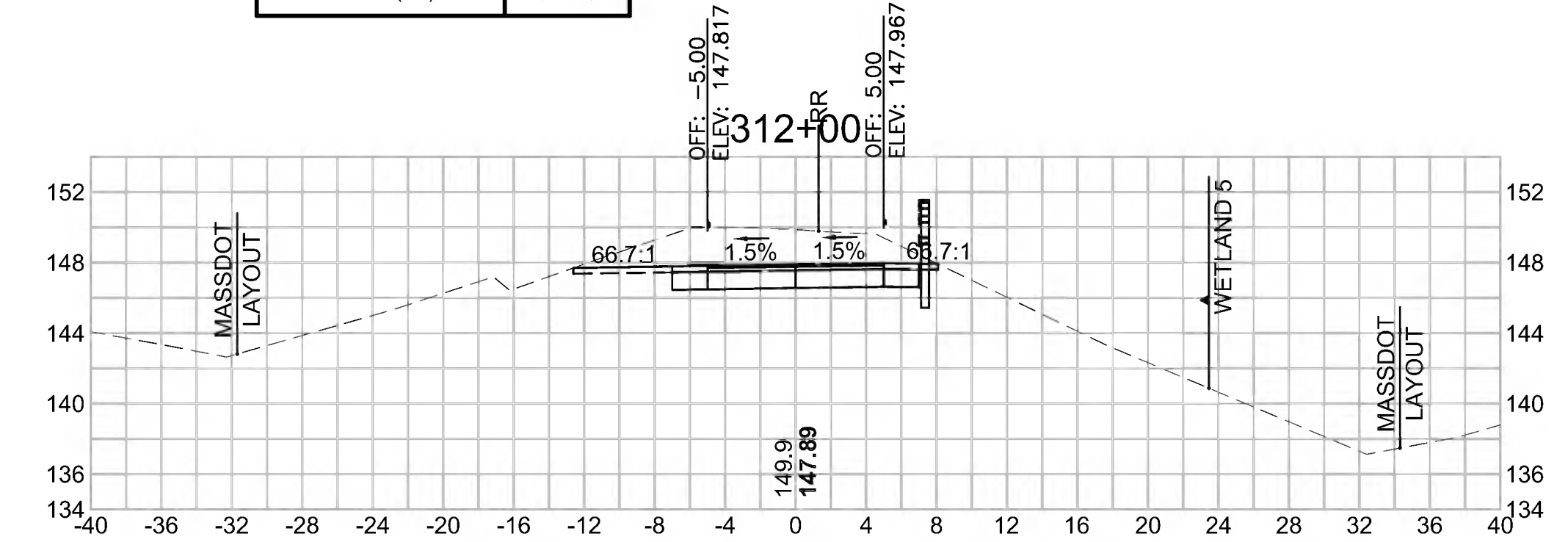

Total Volume at Station 308+50.00	
Cut Area (SF)	26.103
Fill Area (SF)	0.096
Cut Vol (CF)	41.1
Fill Vol (CF)	15.0
Cum Cut Vol (CF)	13230.7
Cum Fill Vol (CF)	8363.9
Net Vol (CF)	4866.8

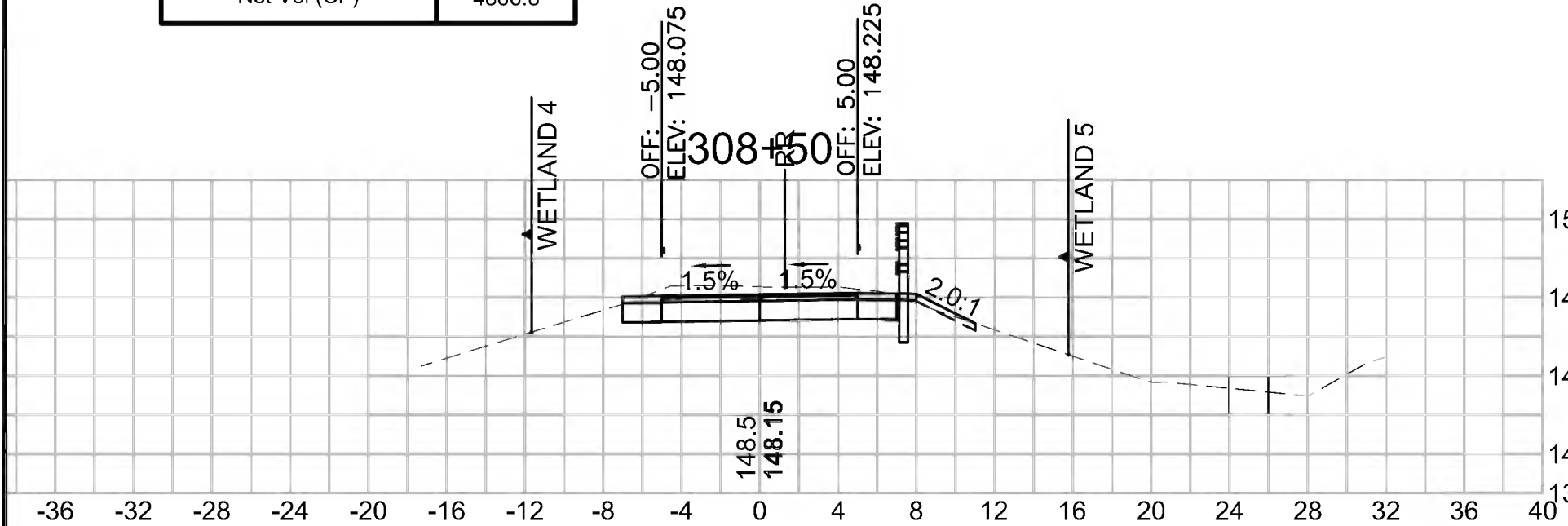

Total Volume at Station 310+00.00	
Cut Area (SF)	47.665
Fill Area (SF)	0.000
Cut Vol (CF)	82.3
Fill Vol (CF)	5.2
Cum Cut Vol (CF)	13428.7
Cum Fill Vol (CF)	8377.3
Net Vol (CF)	5051.5

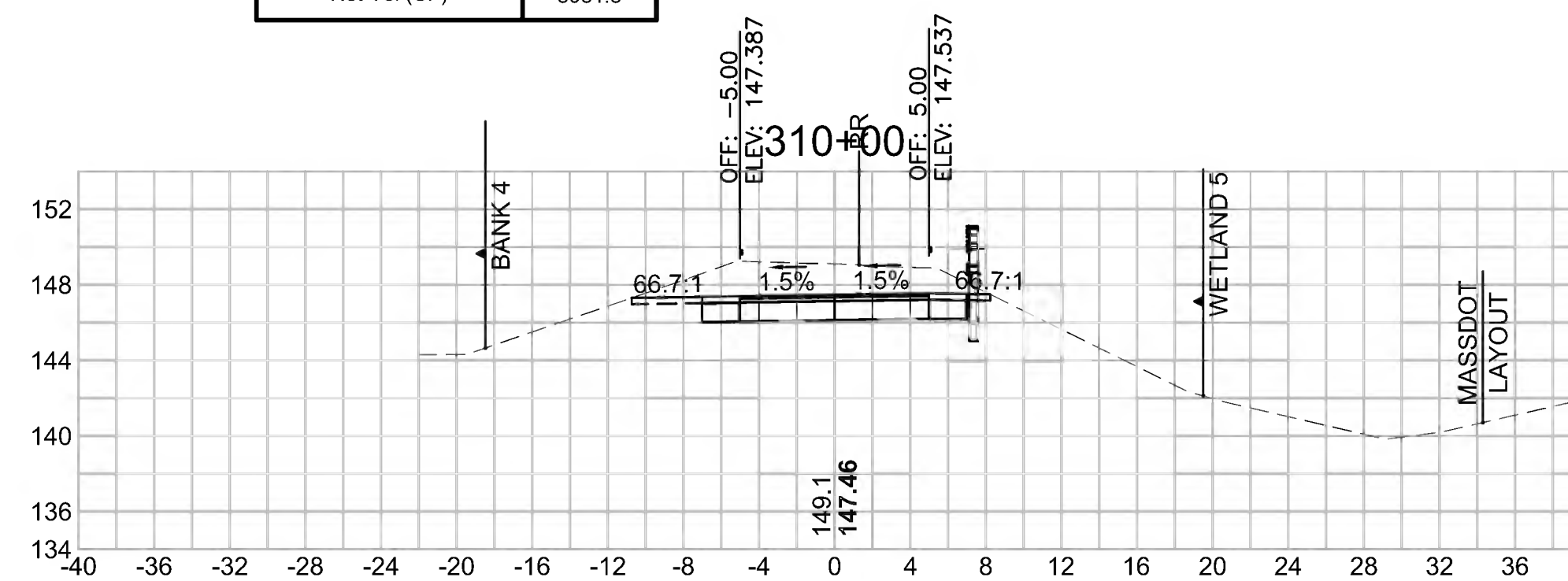

Total Volume at Station 311+50.00	
Cut Area (SF)	68.474
Fill Area (SF)	0.000
Cut Vol (CF)	120.6
Fill Vol (CF)	0.2
Cum Cut Vol (CF)	13738.0
Cum Fill Vol (CF)	8377.6
Net Vol (CF)	5360.4

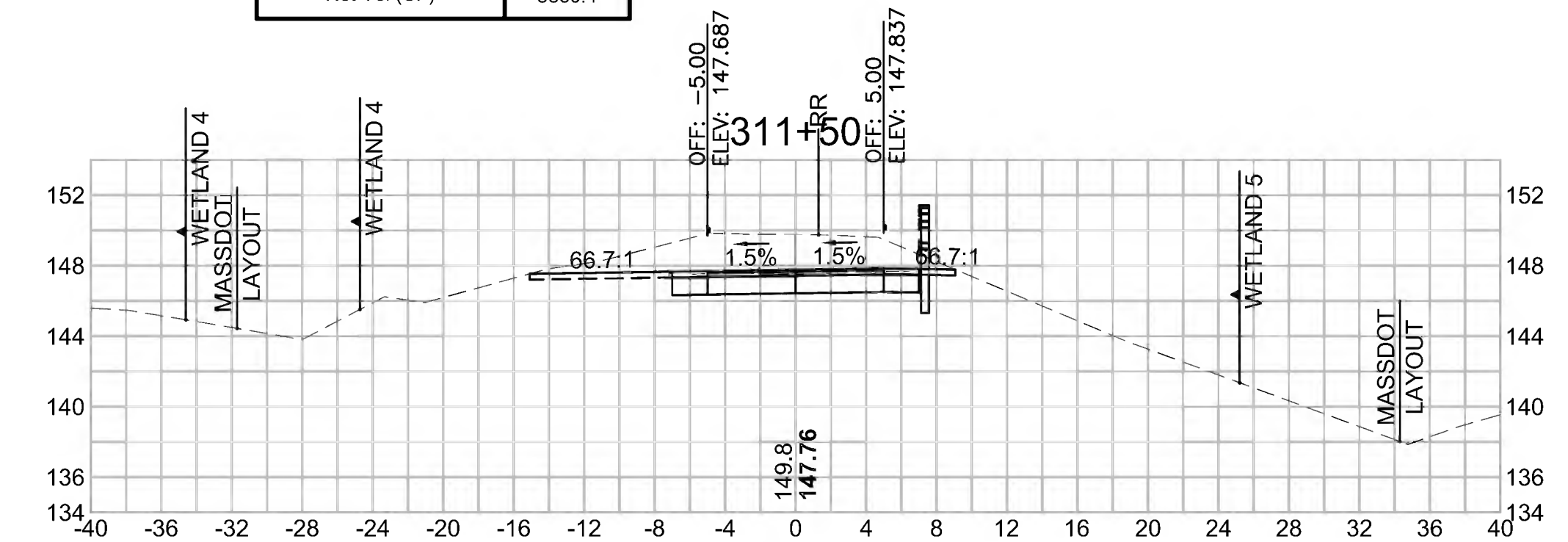

Total Volume at Station 308+00.00	
Cut Area (SF)	18.272
Fill Area (SF)	16.066
Cut Vol (CF)	90.7
Fill Vol (CF)	14.9
Cum Cut Vol (CF)	13189.6
Cum Fill Vol (CF)	8348.9
Net Vol (CF)	4840.7

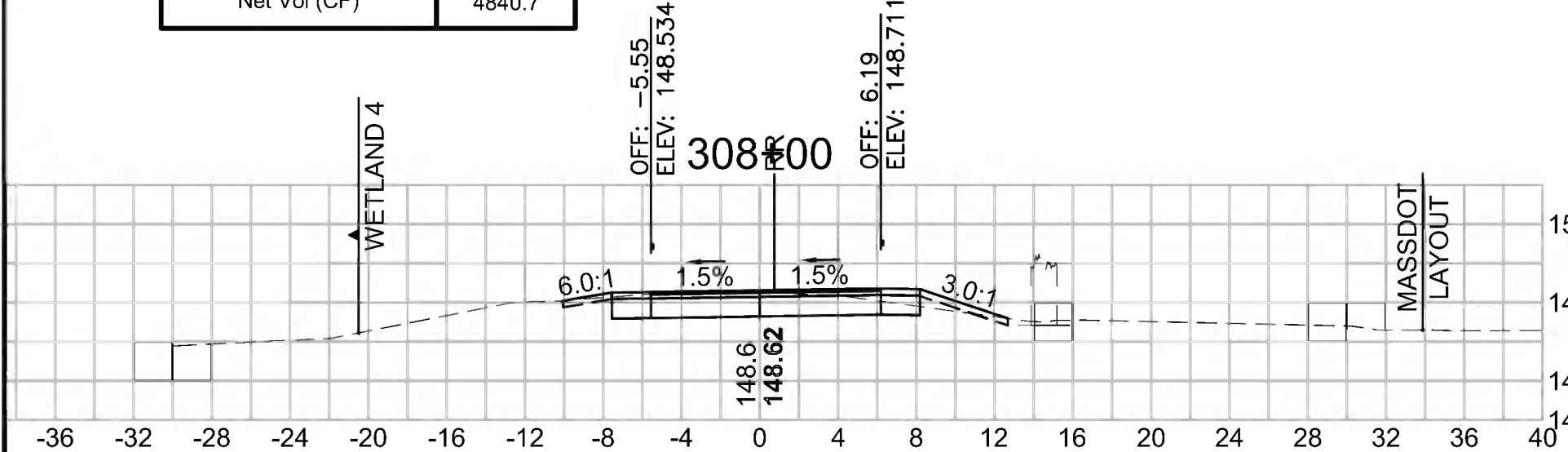

Total Volume at Station 309+50.00	
Cut Area (SF)	41.186
Fill Area (SF)	5.665
Cut Vol (CF)	64.9
Fill Vol (CF)	6.7
Cum Cut Vol (CF)	13346.4
Cum Fill Vol (CF)	8372.0
Net Vol (CF)	4974.4



Total Volume at Station 311+00.00	
Cut Area (SF)	61.726
Fill Area (SF)	0.185
Cut Vol (CF)	100.9
Fill Vol (CF)	0.2
Cum Cut Vol (CF)	13617.4
Cum Fill Vol (CF)	8377.4
Net Vol (CF)	5240.0

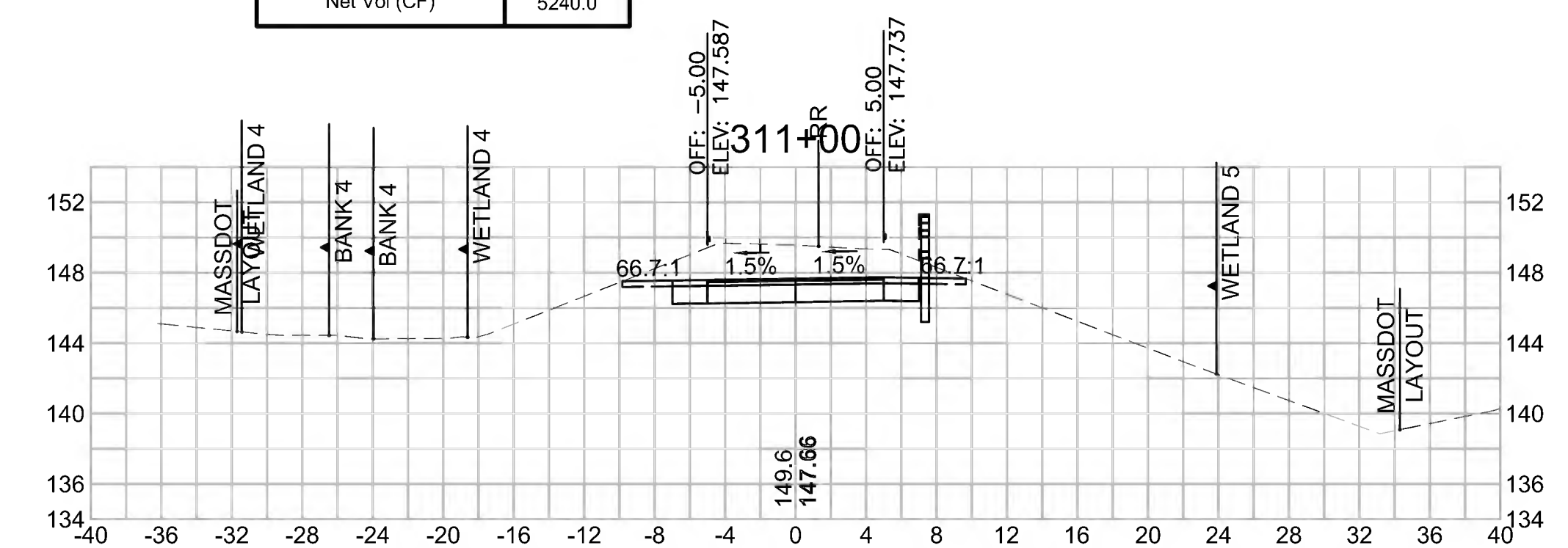

SUDBURY
BRUCE FREEMAN RAIL TRAIL

STATE	FED. AID PROJ. NO.	SHEET NO.	TOTAL SHEETS
MA	XXX-XXXX(XXX)X	295	319
PROJECT FILE NO. 608164			

CROSS SECTIONS

18-Feb-2022
608164.XSEC(CROSS SECTION LAYOUTS).DWG

Total Volume at Station 313+00.00

Cut Area (SF)	46.228
Fill Area (SF)	0.000
Cut Vol (CF)	92.3
Fill Vol (CF)	0.0
Cum Cut Vol (CF)	14052.8
Cum Fill Vol (CF)	8377.8
Net Vol (CF)	5674.9

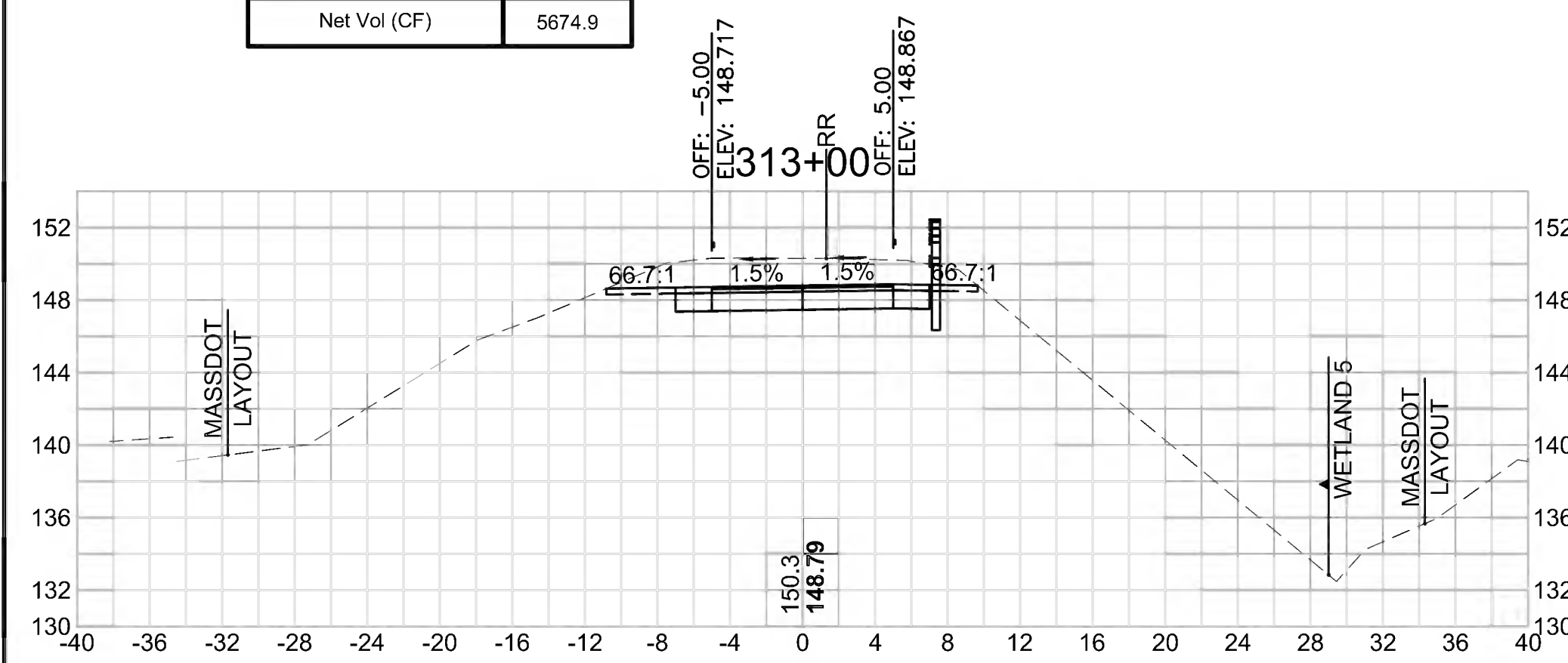

Total Volume at Station 314+00.00

Cut Area (SF)	38.540
Fill Area (SF)	0.000
Cut Vol (CF)	76.1
Fill Vol (CF)	0.0
Cum Cut Vol (CF)	14212.1
Cum Fill Vol (CF)	8377.9
Net Vol (CF)	5834.2

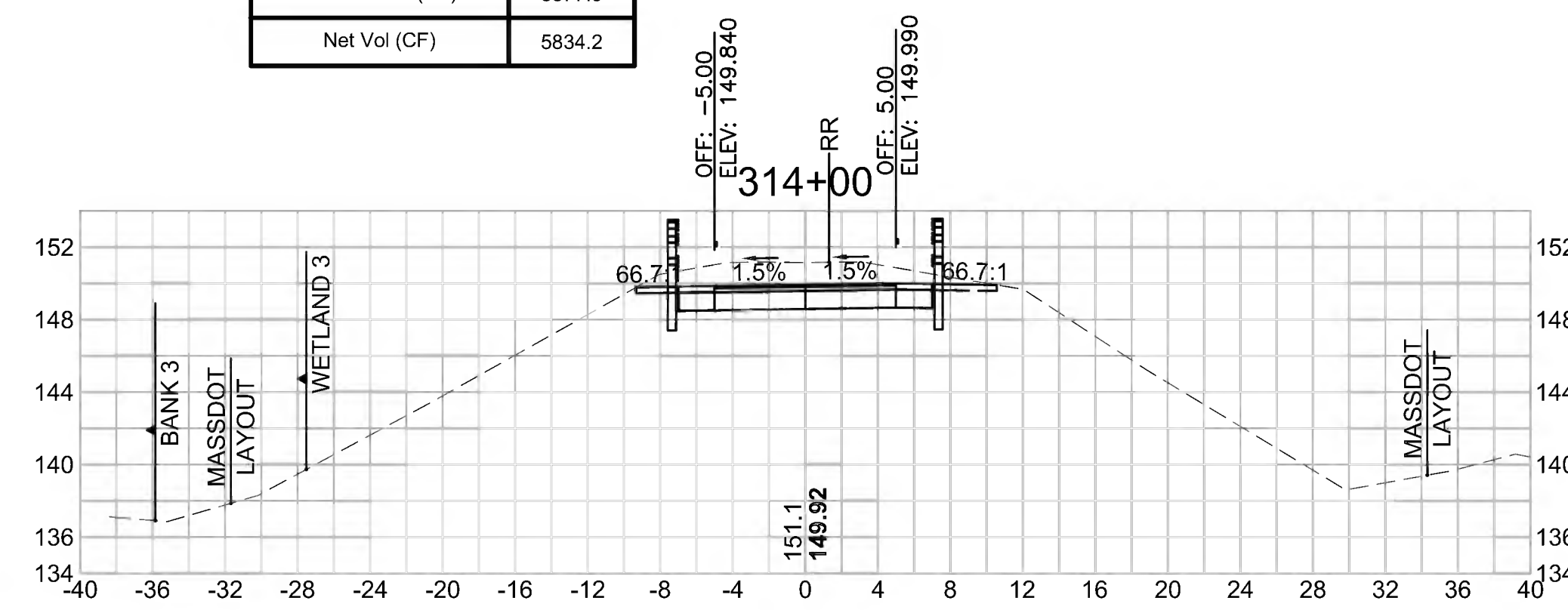

Total Volume at Station 315+00.00

Cut Area (SF)	29.539
Fill Area (SF)	0.000
Cut Vol (CF)	58.4
Fill Vol (CF)	0.0
Cum Cut Vol (CF)	14337.3
Cum Fill Vol (CF)	8377.9
Net Vol (CF)	5959.4

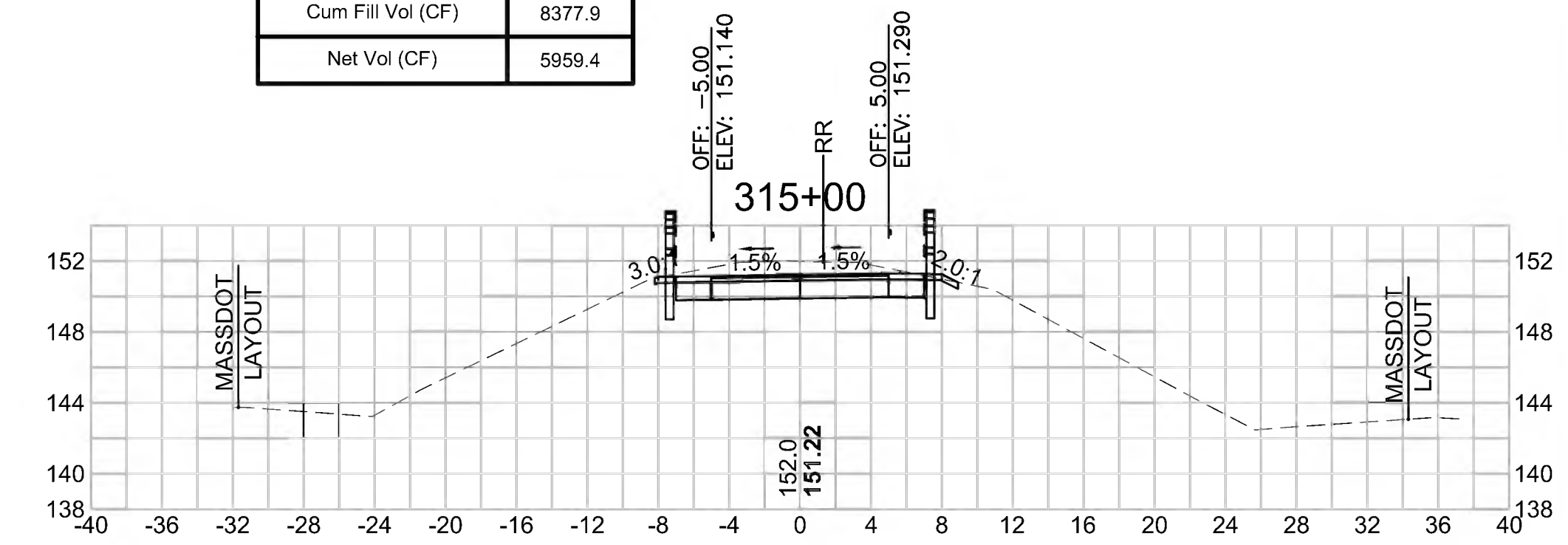

Total Volume at Station 312+50.00

Cut Area (SF)	53.434
Fill Area (SF)	0.000
Cut Vol (CF)	104.3
Fill Vol (CF)	0.1
Cum Cut Vol (CF)	13960.5
Cum Fill Vol (CF)	8377.8
Net Vol (CF)	5582.7

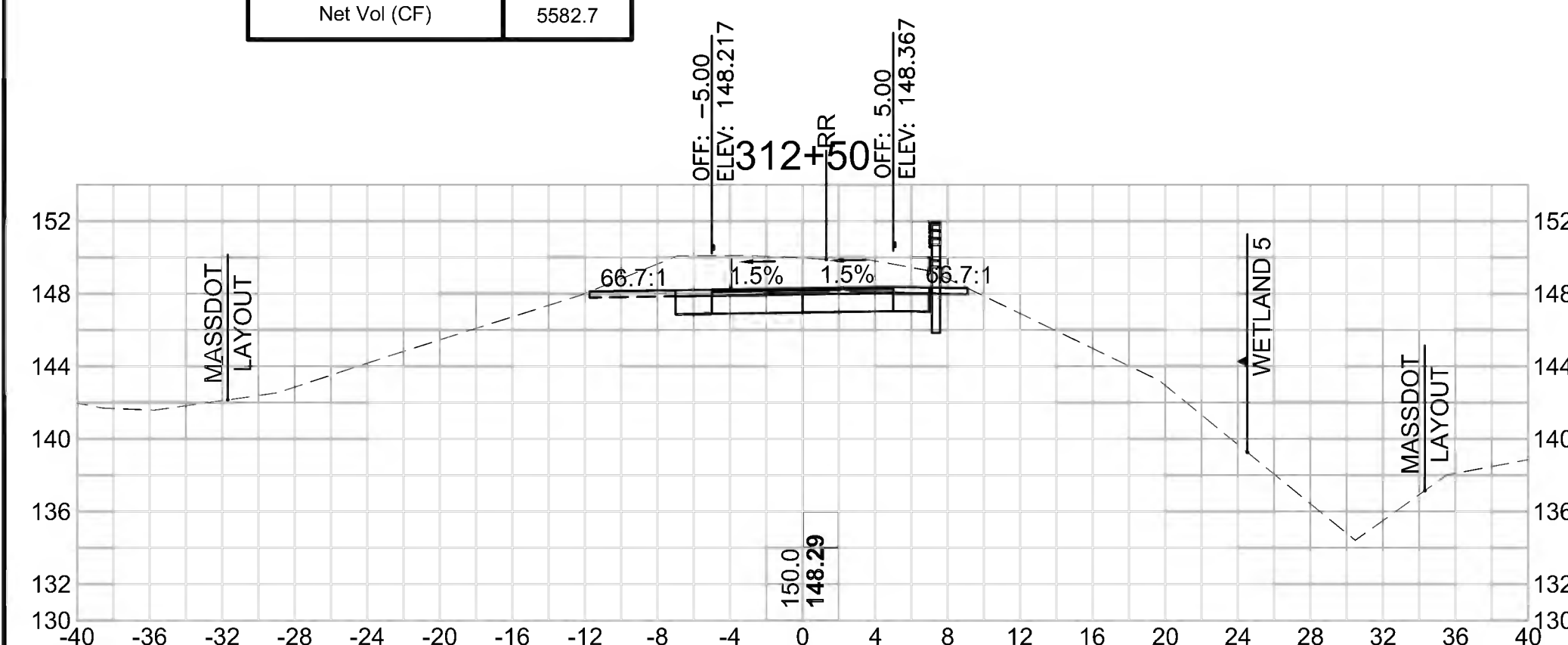

Total Volume at Station 313+50.00

Cut Area (SF)	43.650
Fill Area (SF)	0.018
Cut Vol (CF)	83.2
Fill Vol (CF)	0.0
Cum Cut Vol (CF)	14136.0
Cum Fill Vol (CF)	8377.8
Net Vol (CF)	5758.2

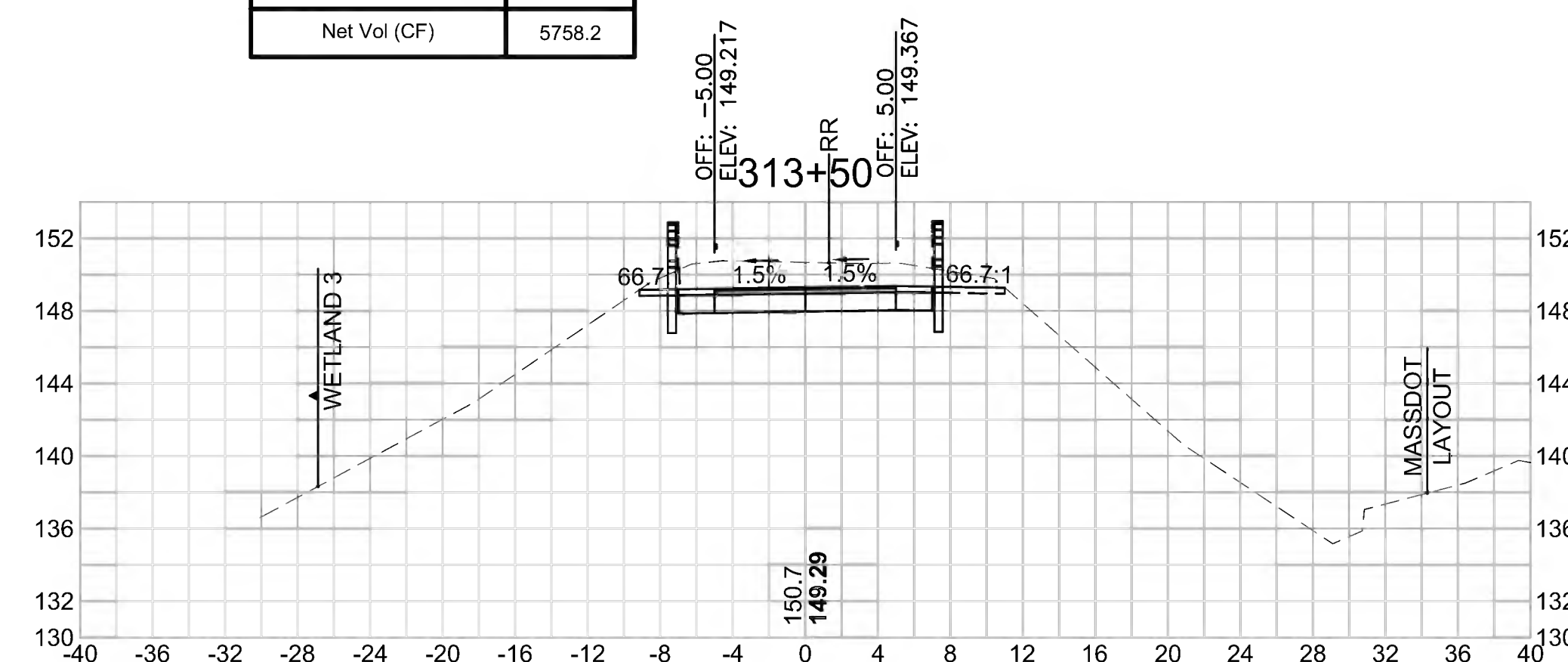

Total Volume at Station 314+50.00

Cut Area (SF)	33.549
Fill Area (SF)	0.000
Cut Vol (CF)	66.7
Fill Vol (CF)	0.0
Cum Cut Vol (CF)	14278.8
Cum Fill Vol (CF)	8377.9
Net Vol (CF)	5901.0

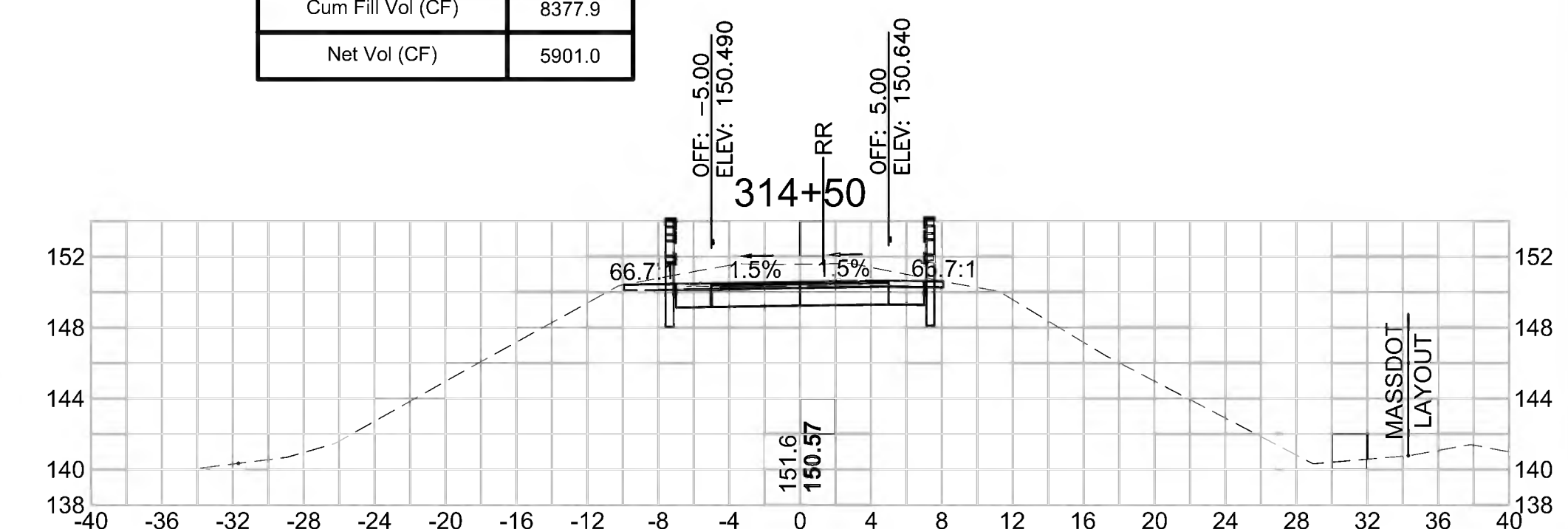

SUDBURY
BRUCE FREEMAN RAIL TRAIL

STATE	FED. AID PROJ. NO.	SHEET NO.	TOTAL SHEETS
MA	XXX-XXXX(XXX)X	296	319

PROJECT FILE NO. 608164

CROSS SECTIONS

608164_XSEC(CROSS SECTION LAYOUTS).DWG 18-Feb-2022

Total Volume at Station 316+50.00

Cut Area (SF)	18.222
Fill Area (SF)	1.292
Cut Vol (CF)	30.0
Fill Vol (CF)	5.5
Cum Cut Vol (CF)	14446.4
Cum Fill Vol (CF)	8392.3
Net Vol (CF)	6054.1

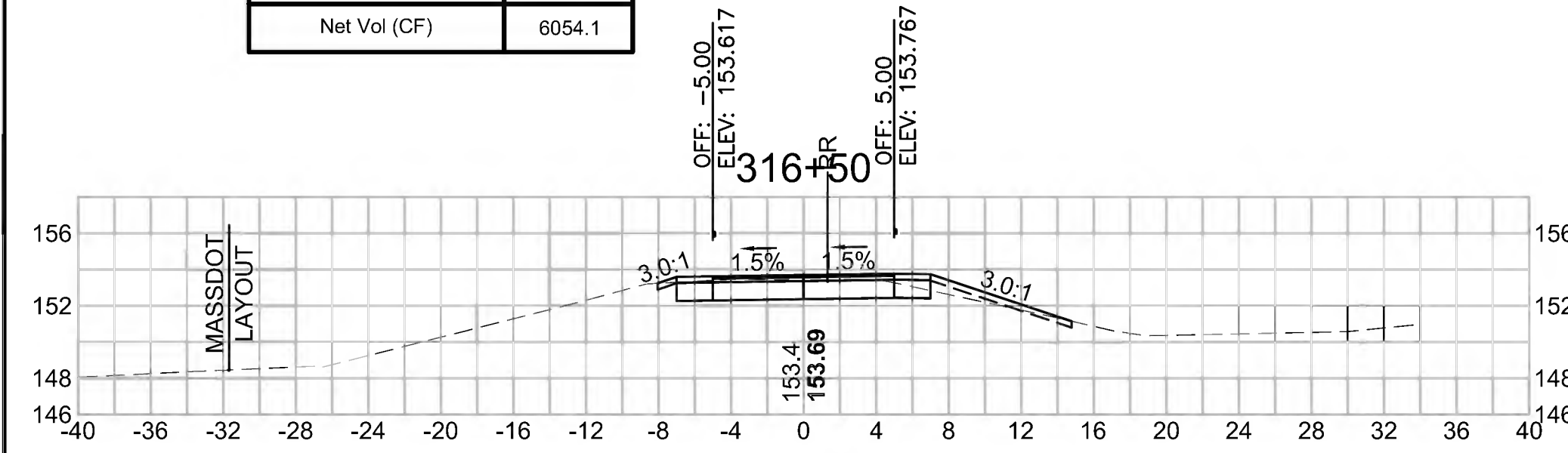

Total Volume at Station 318+00.00

Cut Area (SF)	15.594
Fill Area (SF)	0.080
Cut Vol (CF)	28.5
Fill Vol (CF)	0.1
Cum Cut Vol (CF)	14532.8
Cum Fill Vol (CF)	8394.8
Net Vol (CF)	6138.1

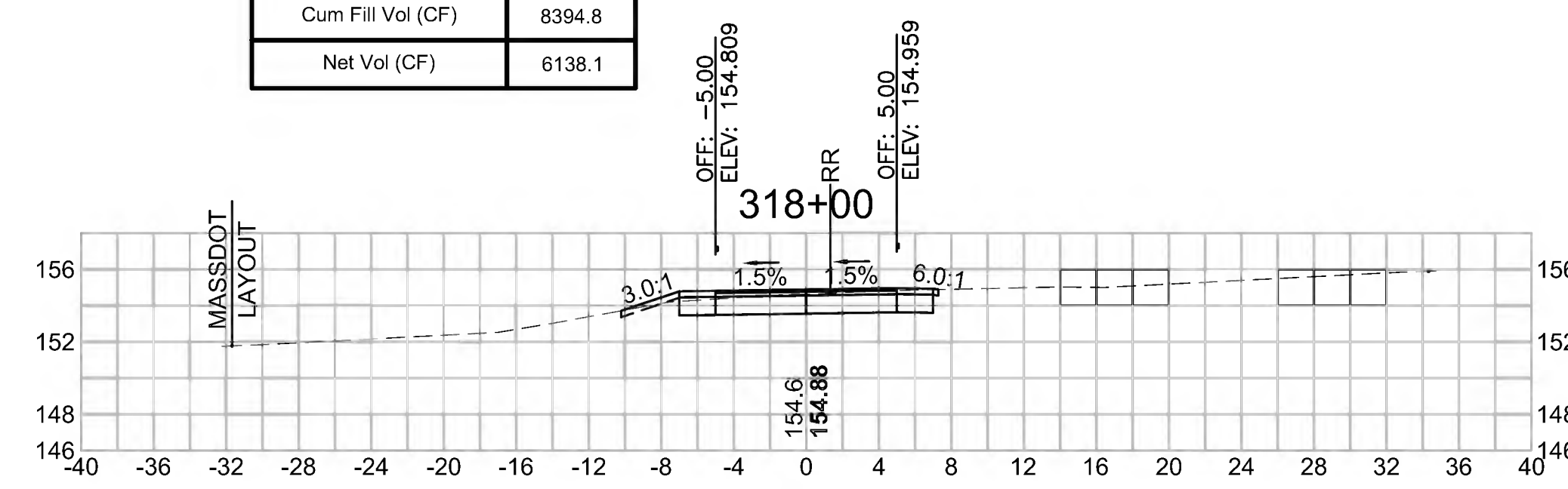

Total Volume at Station 319+50.00

Cut Area (SF)	24.589
Fill Area (SF)	0.078
Cut Vol (CF)	36.6
Fill Vol (CF)	1.8
Cum Cut Vol (CF)	14626.9
Cum Fill Vol (CF)	8400.1
Net Vol (CF)	6226.8

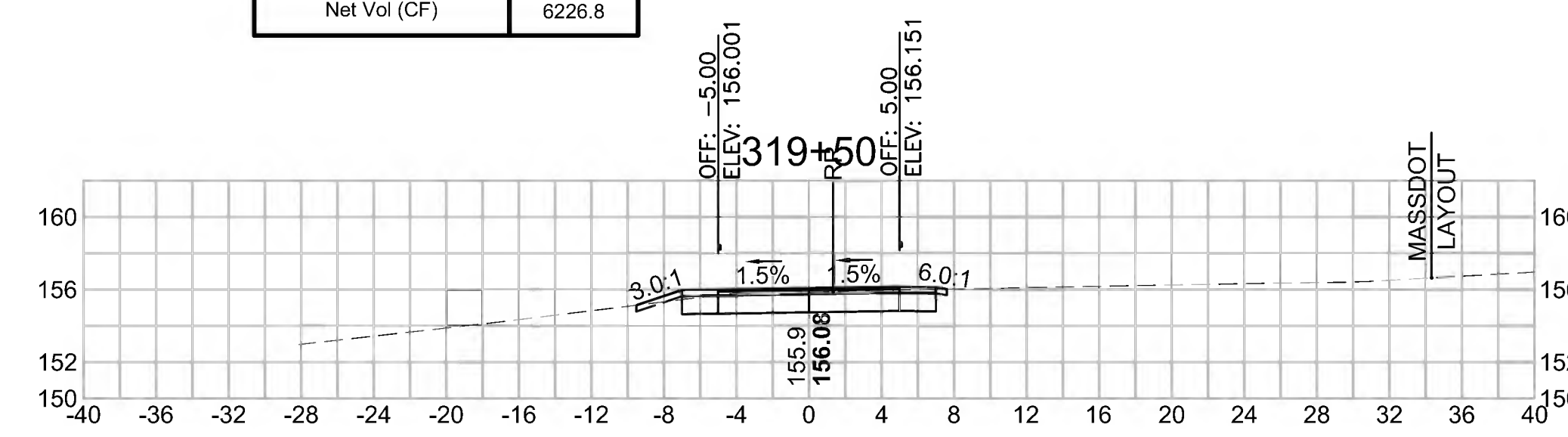

Total Volume at Station 316+00.00

Cut Area (SF)	14.228
Fill Area (SF)	4.661
Cut Vol (CF)	32.5
Fill Vol (CF)	6.6
Cum Cut Vol (CF)	14416.4
Cum Fill Vol (CF)	8386.8
Net Vol (CF)	6029.6

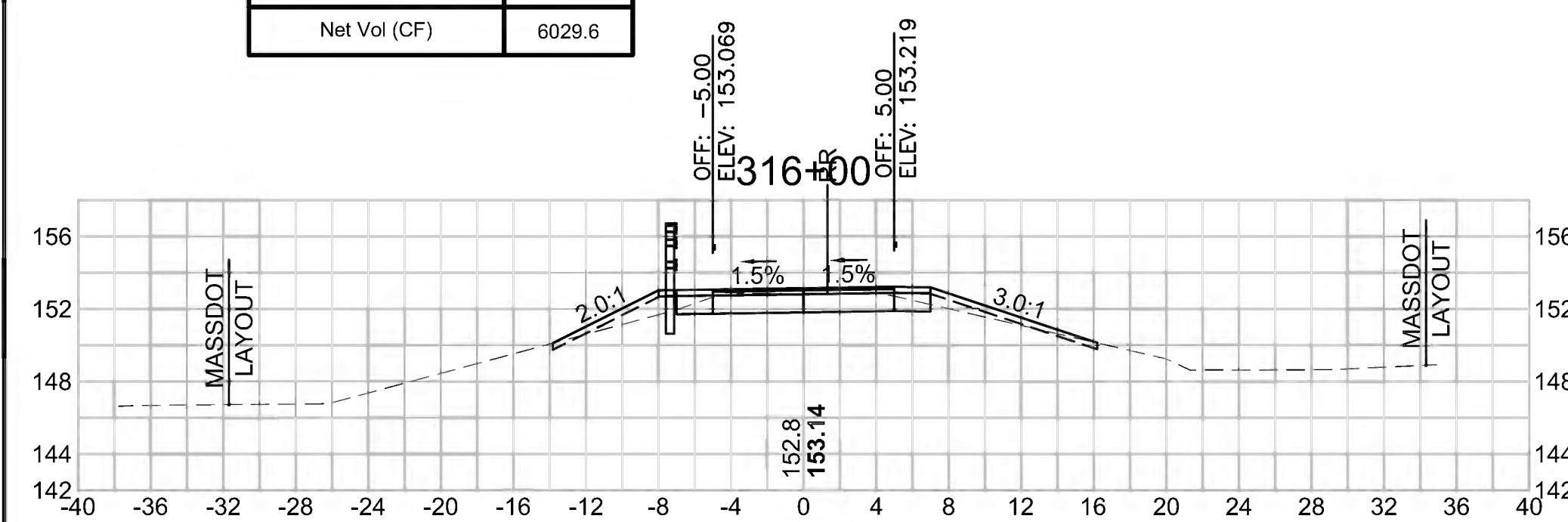

Total Volume at Station 317+50.00

Cut Area (SF)	15.227
Fill Area (SF)	0.021
Cut Vol (CF)	27.6
Fill Vol (CF)	0.6
Cum Cut Vol (CF)	14504.3
Cum Fill Vol (CF)	8394.7
Net Vol (CF)	6109.6

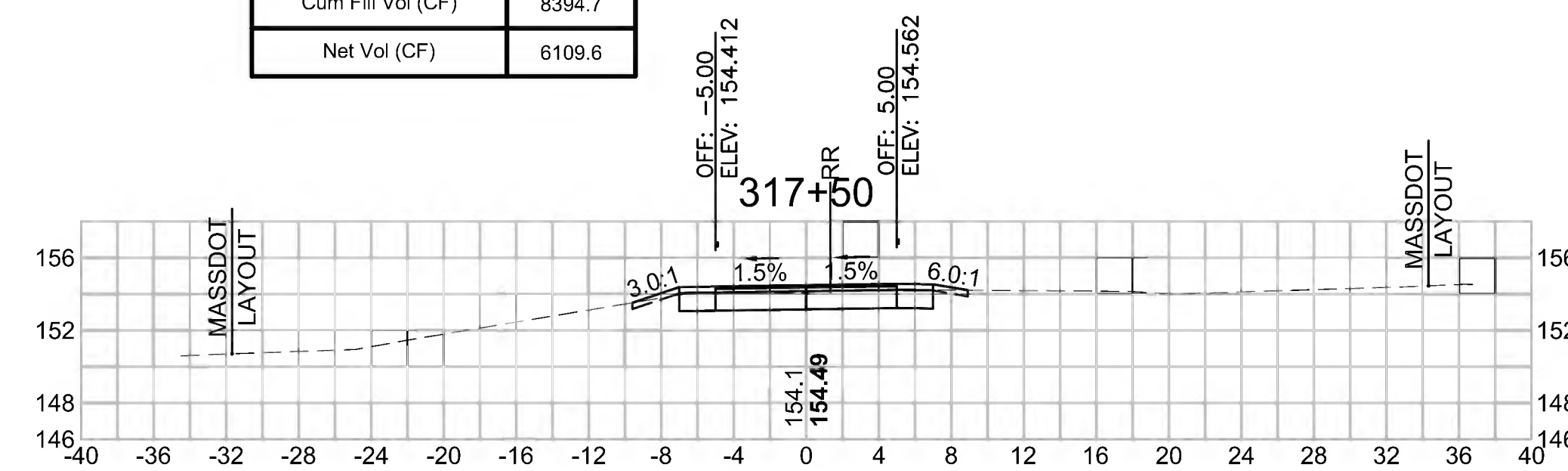

Total Volume at Station 319+00.00

Cut Area (SF)	14.916
Fill Area (SF)	1.909
Cut Vol (CF)	28.4
Fill Vol (CF)	2.6
Cum Cut Vol (CF)	14590.3
Cum Fill Vol (CF)	8398.2
Net Vol (CF)	6192.1

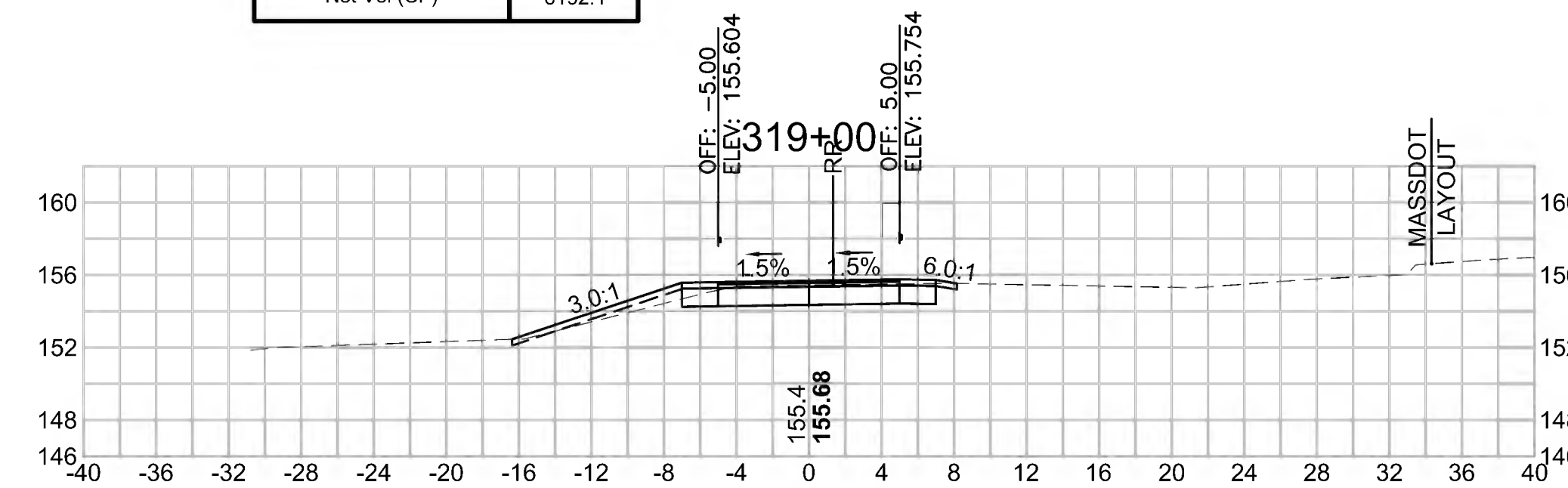

Total Volume at Station 315+50.00

Cut Area (SF)	20.826
Fill Area (SF)	2.479
Cut Vol (CF)	46.6
Fill Vol (CF)	2.3
Cum Cut Vol (CF)	14383.9
Cum Fill Vol (CF)	8380.2
Net Vol (CF)	6003.7

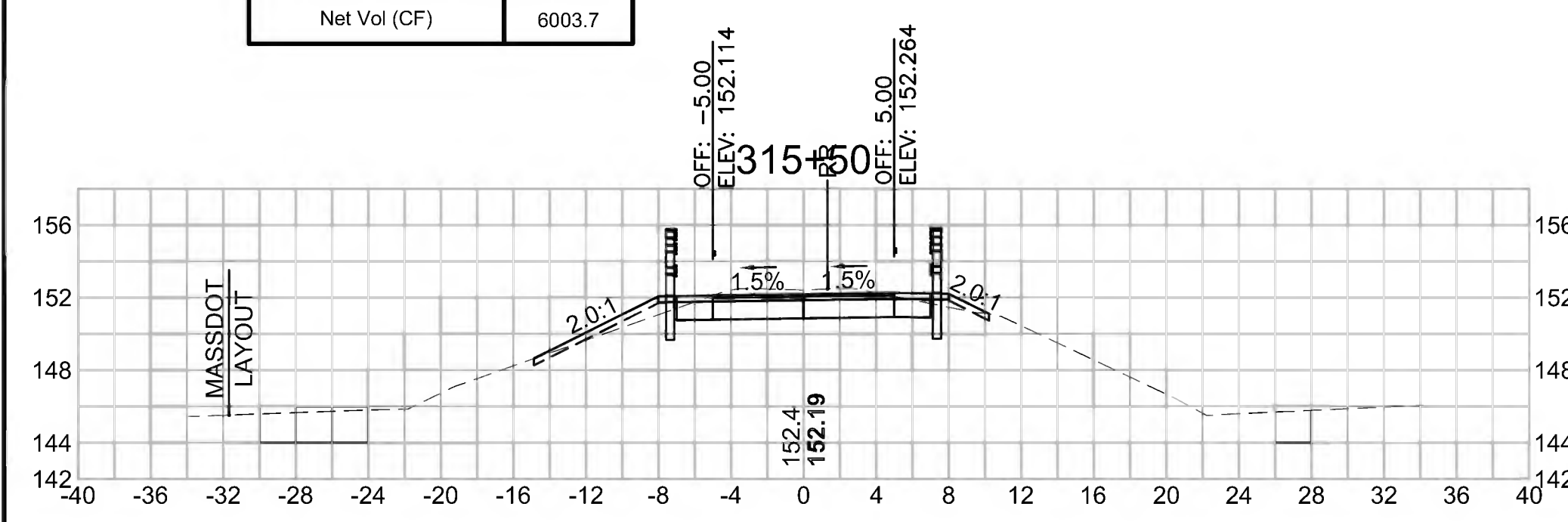

Total Volume at Station 317+00.00

Cut Area (SF)	14.546
Fill Area (SF)	0.634
Cut Vol (CF)	30.3
Fill Vol (CF)	1.8
Cum Cut Vol (CF)	14476.7
Cum Fill Vol (CF)	8394.1
Net Vol (CF)	6082.7

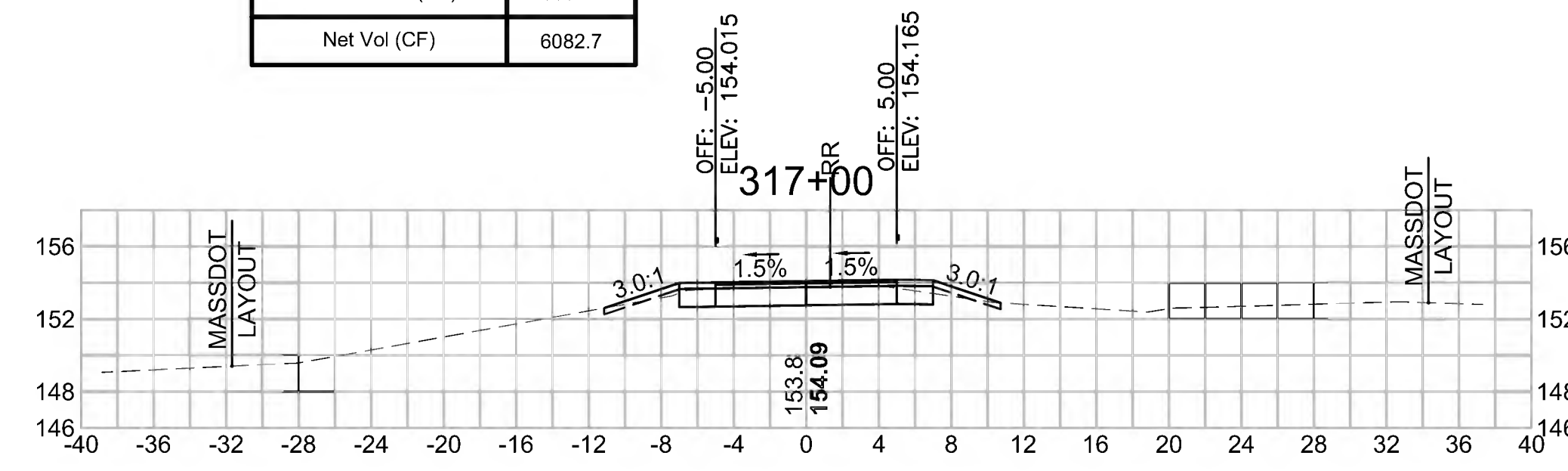

Total Volume at Station 318+50.00

Cut Area (SF)	15.772
Fill Area (SF)	0.874
Cut Vol (CF)	29.0
Fill Vol (CF)	0.9
Cum Cut Vol (CF)	14561.9
Cum Fill Vol (CF)	8395.6
Net Vol (CF)	6166.2

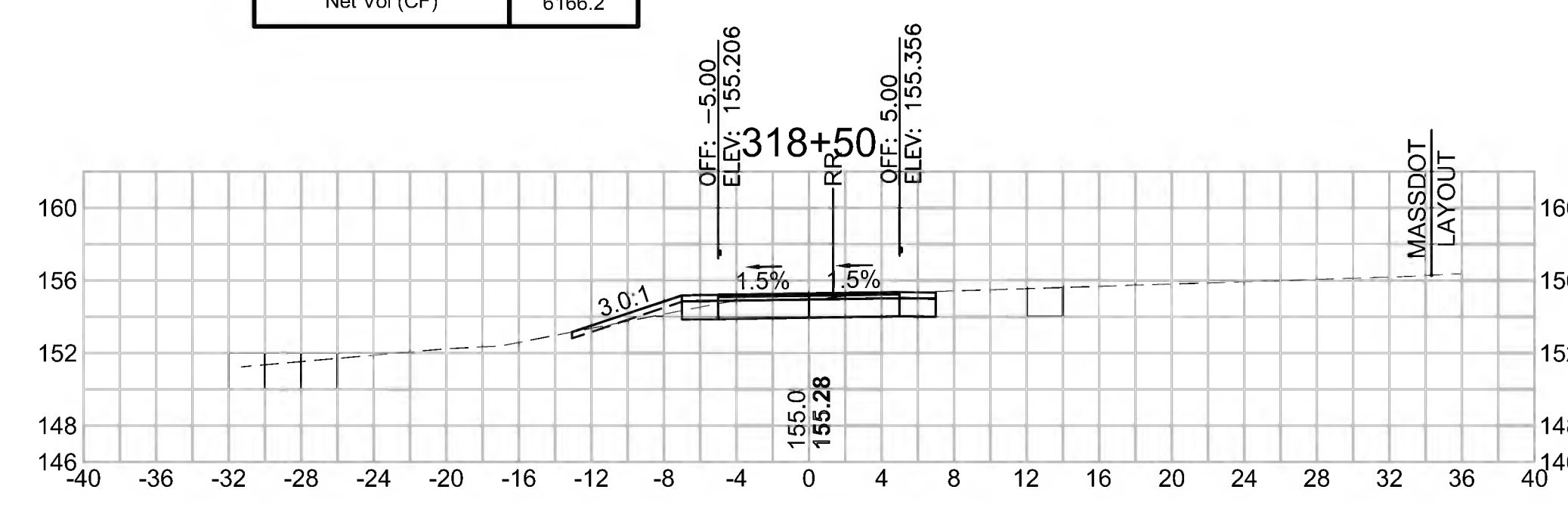

SUDBURY
BRUCE FREEMAN RAIL TRAIL

STATE	FED. AID PROJ. NO.	SHEET NO.	TOTAL SHEETS
MA	XXX-XXXX(XXX)X	297	319

PROJECT FILE NO. 608164

CROSS SECTIONS

608164_XSEC(CROSS SECTION LAYOUTS).DWG 18-Feb-2022

Total Volume at Station 321+00.00	
Cut Area (SF)	26.648
Fill Area (SF)	0.057
Cut Vol (CF)	70.3
Fill Vol (CF)	0.1
Cum Cut Vol (CF)	14826.6
Cum Fill Vol (CF)	8400.2
Net Vol (CF)	6426.4

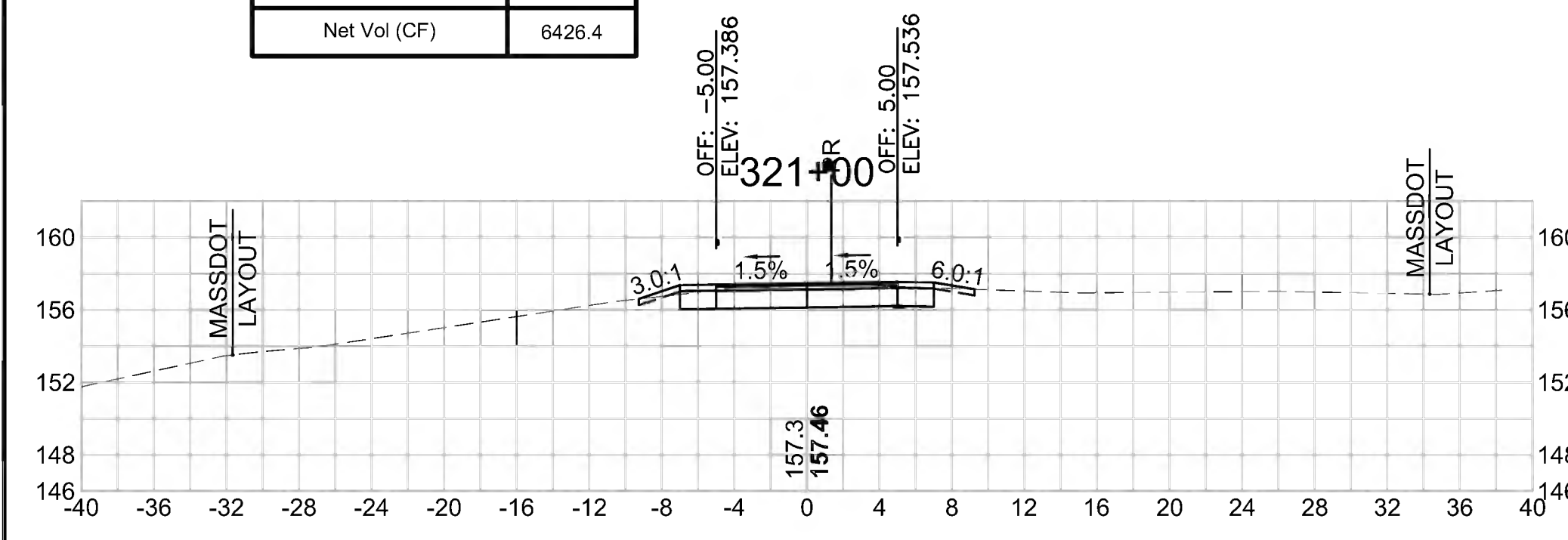

Total Volume at Station 322+50.00	
Cut Area (SF)	37.507
Fill Area (SF)	3.438
Cut Vol (CF)	71.9
Fill Vol (CF)	5.7
Cum Cut Vol (CF)	15010.8
Cum Fill Vol (CF)	8411.7
Net Vol (CF)	6599.1

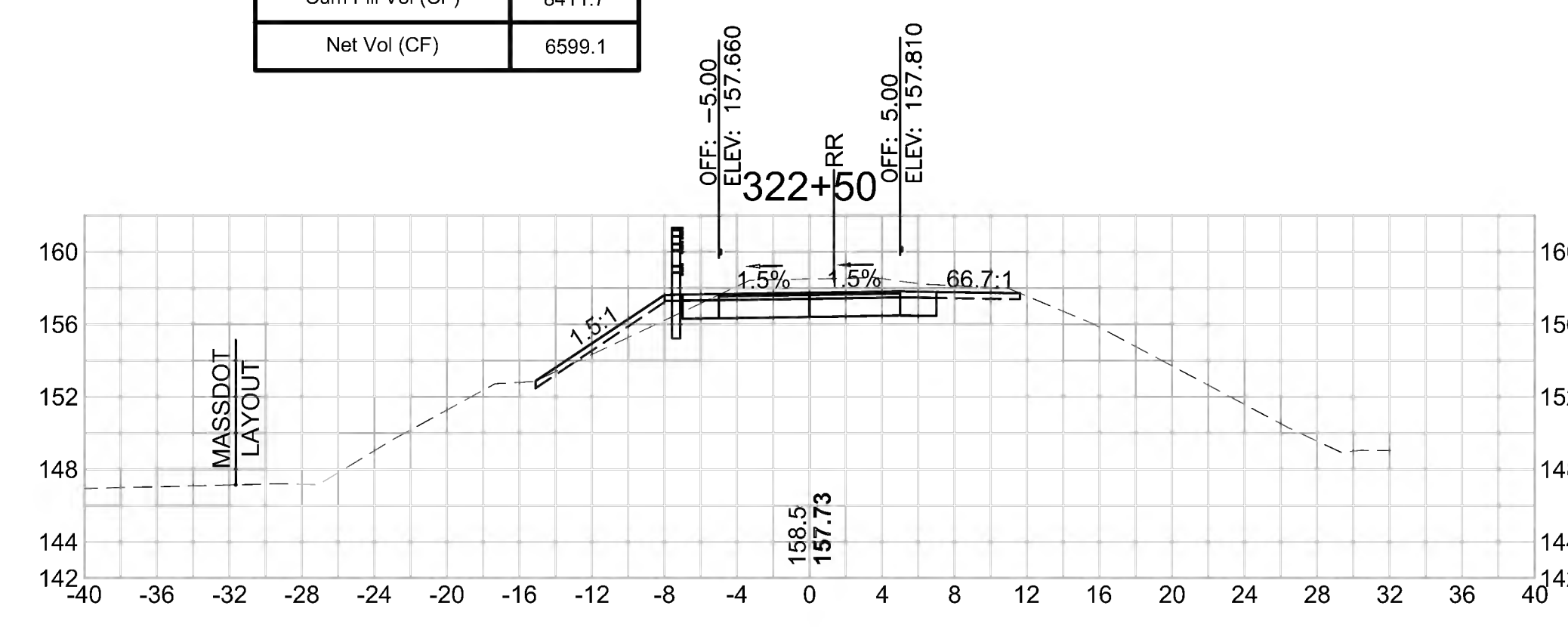

Total Volume at Station 320+50.00	
Cut Area (SF)	49.256
Fill Area (SF)	0.000
Cut Vol (CF)	76.1
Fill Vol (CF)	0.0
Cum Cut Vol (CF)	14756.3
Cum Fill Vol (CF)	8400.1
Net Vol (CF)	6356.2

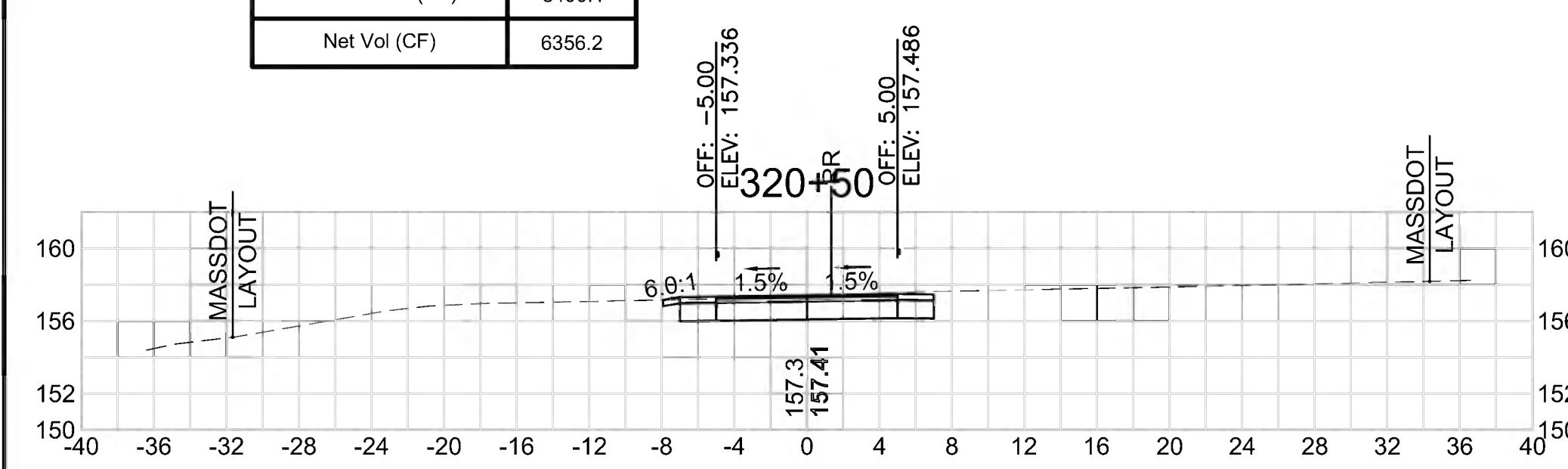

Total Volume at Station 322+00.00	
Cut Area (SF)	40.113
Fill Area (SF)	2.705
Cut Vol (CF)	62.4
Fill Vol (CF)	4.2
Cum Cut Vol (CF)	14938.9
Cum Fill Vol (CF)	8406.0
Net Vol (CF)	6532.9

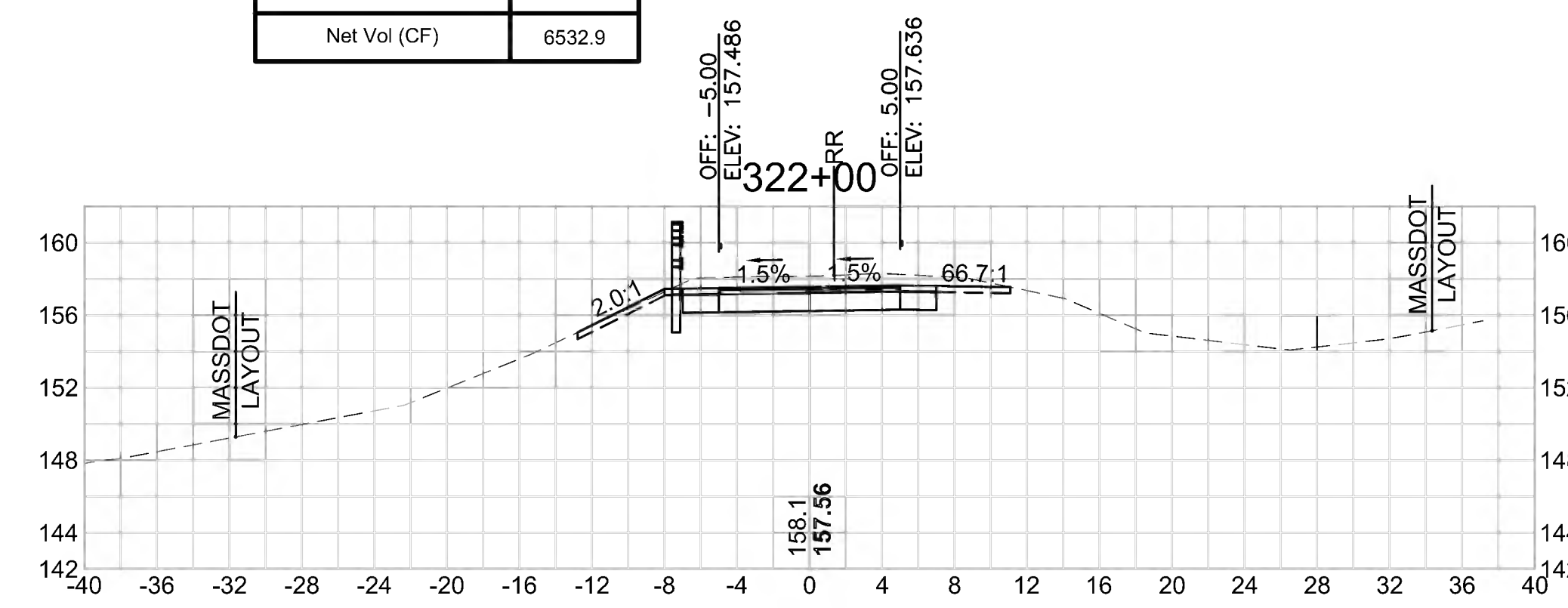

Total Volume at Station 323+50.00	
Cut Area (SF)	45.108
Fill Area (SF)	0.000
Cut Vol (CF)	66.2
Fill Vol (CF)	10.1
Cum Cut Vol (CF)	15136.1
Cum Fill Vol (CF)	8435.2
Net Vol (CF)	6700.9

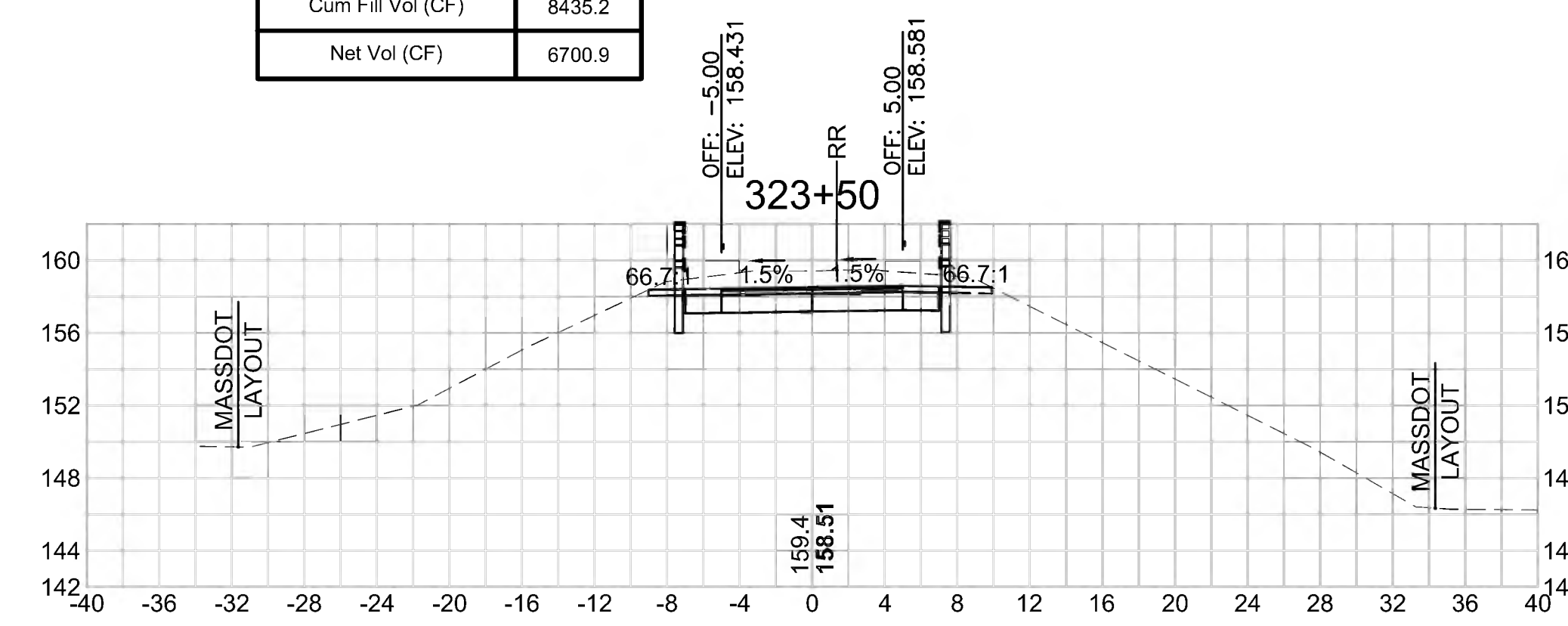

Total Volume at Station 320+00.00	
Cut Area (SF)	32.967
Fill Area (SF)	0.000
Cut Vol (CF)	53.3
Fill Vol (CF)	0.1
Cum Cut Vol (CF)	14680.2
Cum Fill Vol (CF)	8400.1
Net Vol (CF)	6280.0

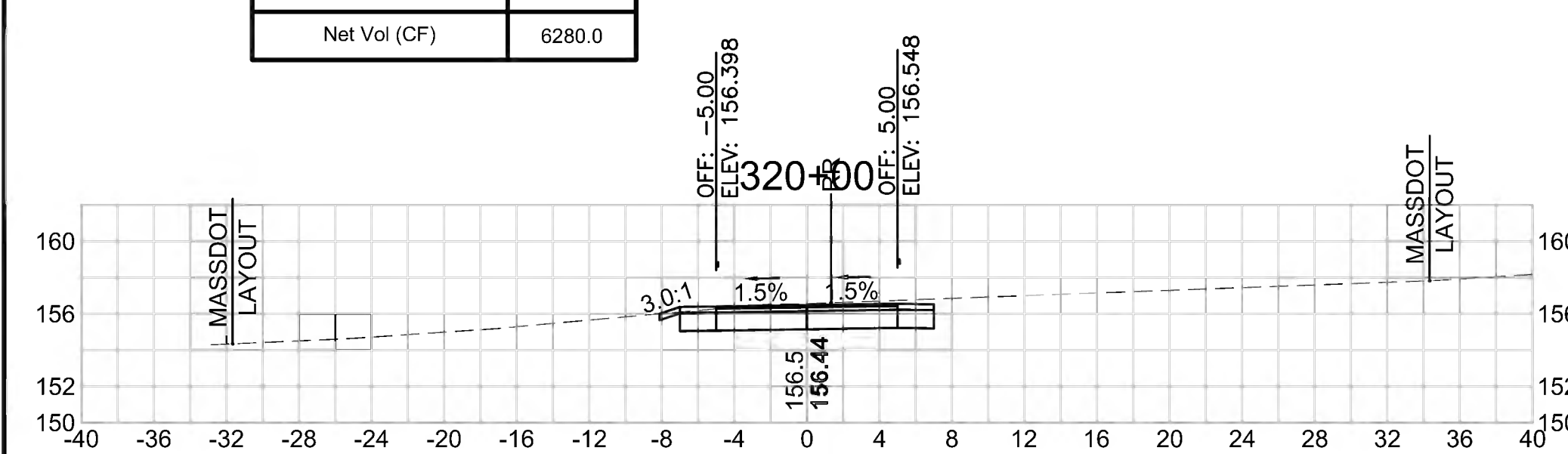

Total Volume at Station 321+50.00	
Cut Area (SF)	27.287
Fill Area (SF)	1.779
Cut Vol (CF)	49.9
Fill Vol (CF)	1.7
Cum Cut Vol (CF)	14876.5
Cum Fill Vol (CF)	8401.9
Net Vol (CF)	6474.6

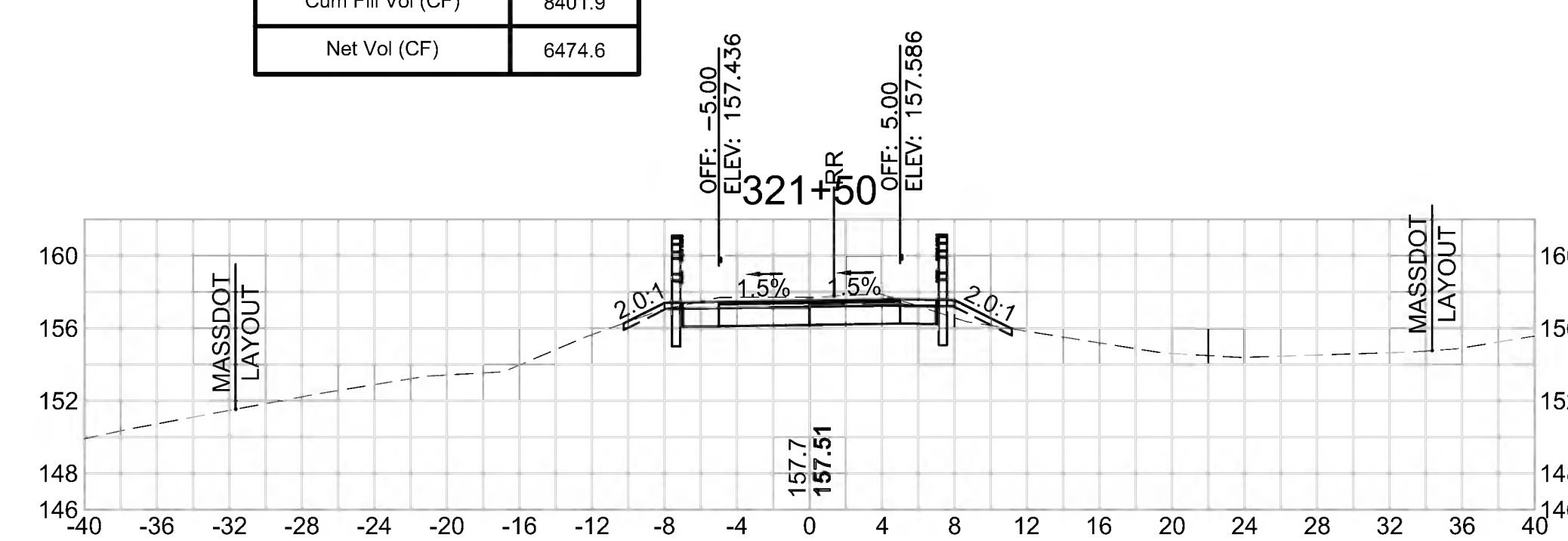

Total Volume at Station 323+00.00	
Cut Area (SF)	26.338
Fill Area (SF)	10.961
Cut Vol (CF)	59.1
Fill Vol (CF)	13.3
Cum Cut Vol (CF)	15069.9
Cum Fill Vol (CF)	8425.1
Net Vol (CF)	6644.9

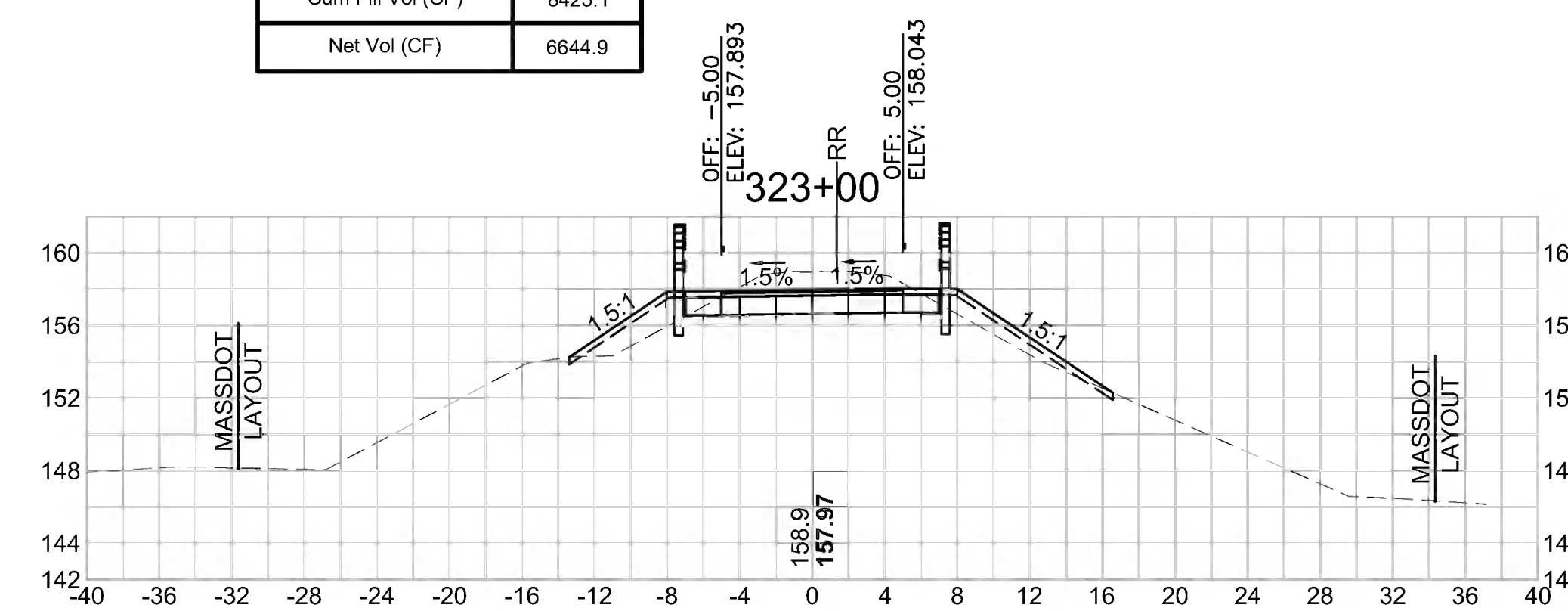

SUDBURY
BRUCE FREEMAN RAIL TRAIL

STATE	FED. AID PROJ. NO.	SHEET NO.	TOTAL SHEETS
MA	XXX-XXXX(XXX)X	298	319

PROJECT FILE NO. 608164

CROSS SECTIONS

18-Feb-2022 608164_XSEC(CROSS SECTION LAYOUTS).DWG

Total Volume at Station 324+50.00	
Cut Area (SF)	35.553
Fill Area (SF)	0.000
Cut Vol (CF)	71.8
Fill Vol (CF)	0.0
Cum Cut Vol (CF)	15288.5
Cum Fill Vol (CF)	8435.2
Net Vol (CF)	6853.2

Total Volume at Station 325+50.00	
Cut Area (SF)	21.576
Fill Area (SF)	0.211
Cut Vol (CF)	51.3
Fill Vol (CF)	0.5
Cum Cut Vol (CF)	15404.0
Cum Fill Vol (CF)	8435.9
Net Vol (CF)	6968.1

Total Volume at Station 326+50.00	
Cut Area (SF)	10.360
Fill Area (SF)	2.731
Cut Vol (CF)	18.9
Fill Vol (CF)	3.4
Cum Cut Vol (CF)	15452.2
Cum Fill Vol (CF)	8440.4
Net Vol (CF)	7011.8

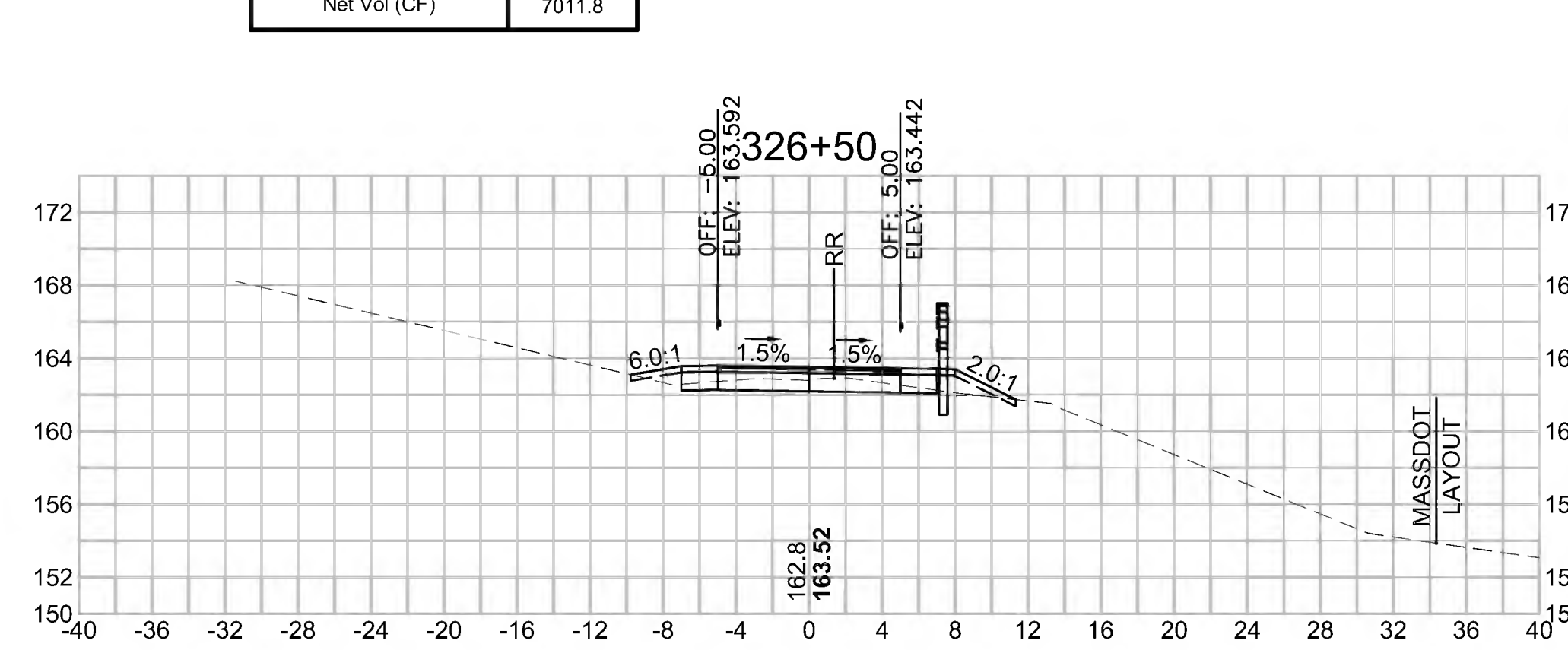
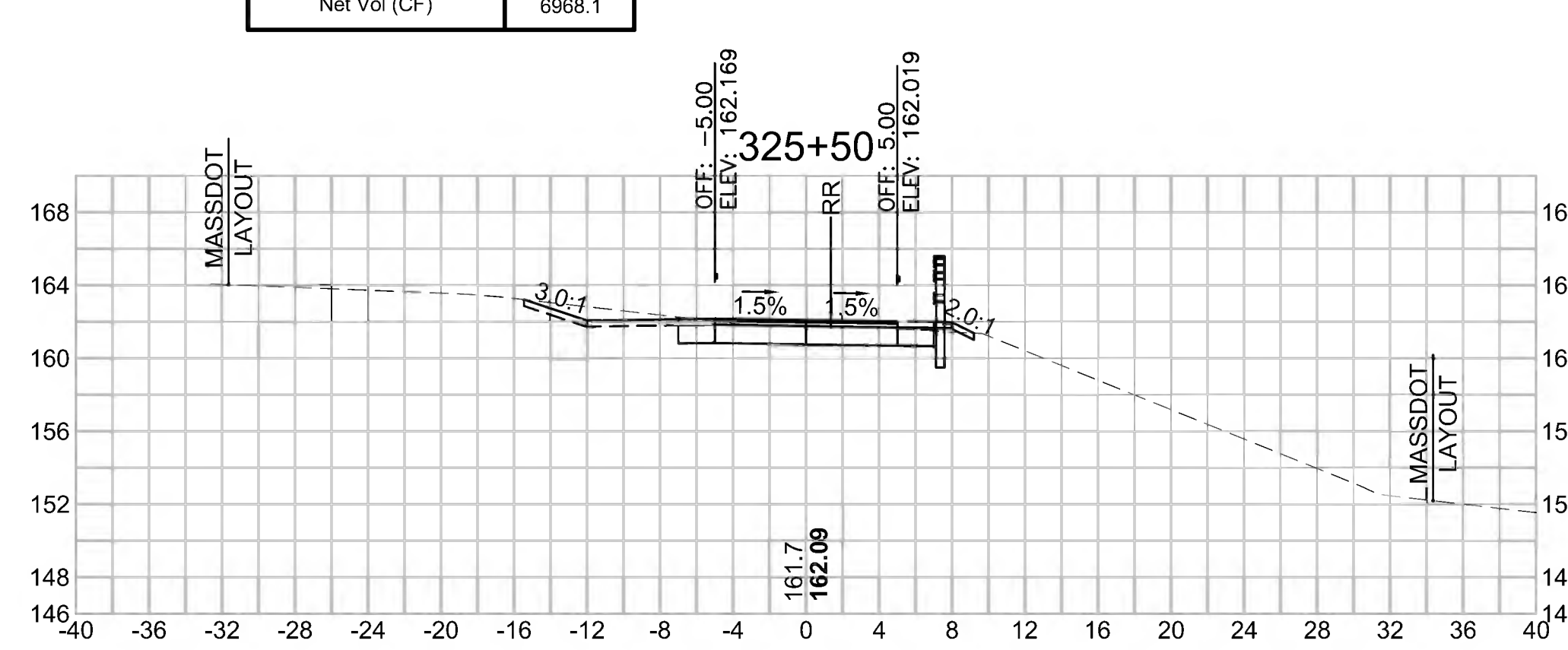
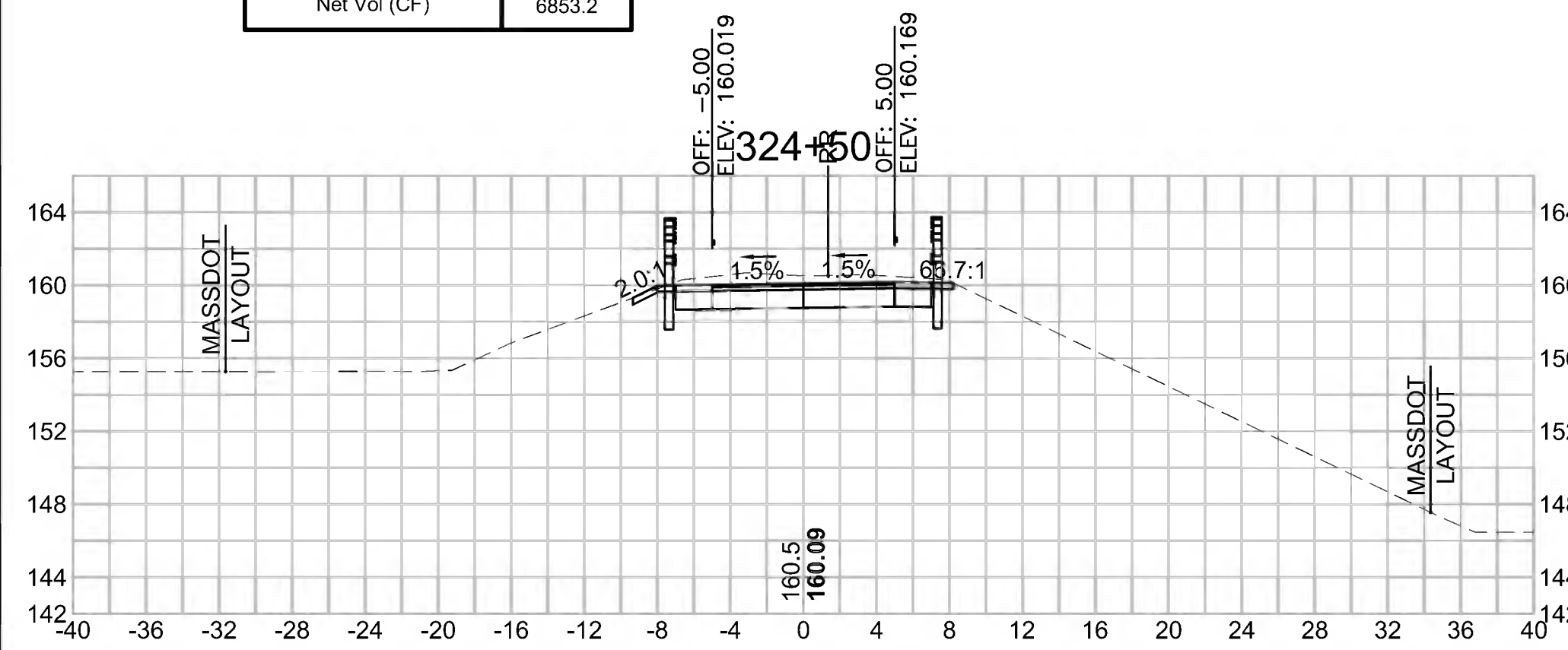

Total Volume at Station 324+00.00	
Cut Area (SF)	41.953
Fill Area (SF)	0.000
Cut Vol (CF)	80.6
Fill Vol (CF)	0.0
Cum Cut Vol (CF)	15216.7
Cum Fill Vol (CF)	8435.2
Net Vol (CF)	6781.5

Total Volume at Station 325+00.00	
Cut Area (SF)	33.840
Fill Area (SF)	0.281
Cut Vol (CF)	64.3
Fill Vol (CF)	0.3
Cum Cut Vol (CF)	15352.7
Cum Fill Vol (CF)	8435.5
Net Vol (CF)	6917.2

Total Volume at Station 326+00.00	
Cut Area (SF)	10.046
Fill Area (SF)	0.925
Cut Vol (CF)	29.3
Fill Vol (CF)	1.1
Cum Cut Vol (CF)	15433.3
Cum Fill Vol (CF)	8437.0
Net Vol (CF)	6996.3

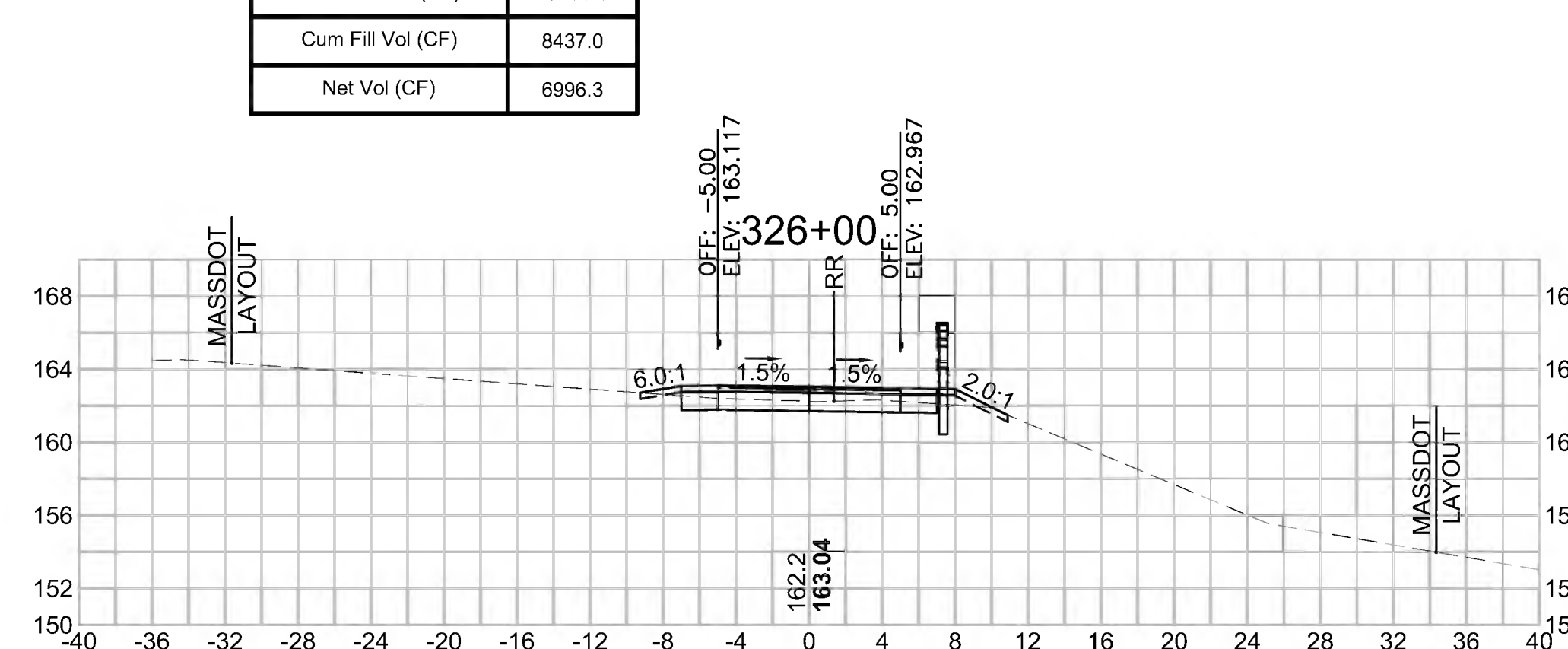
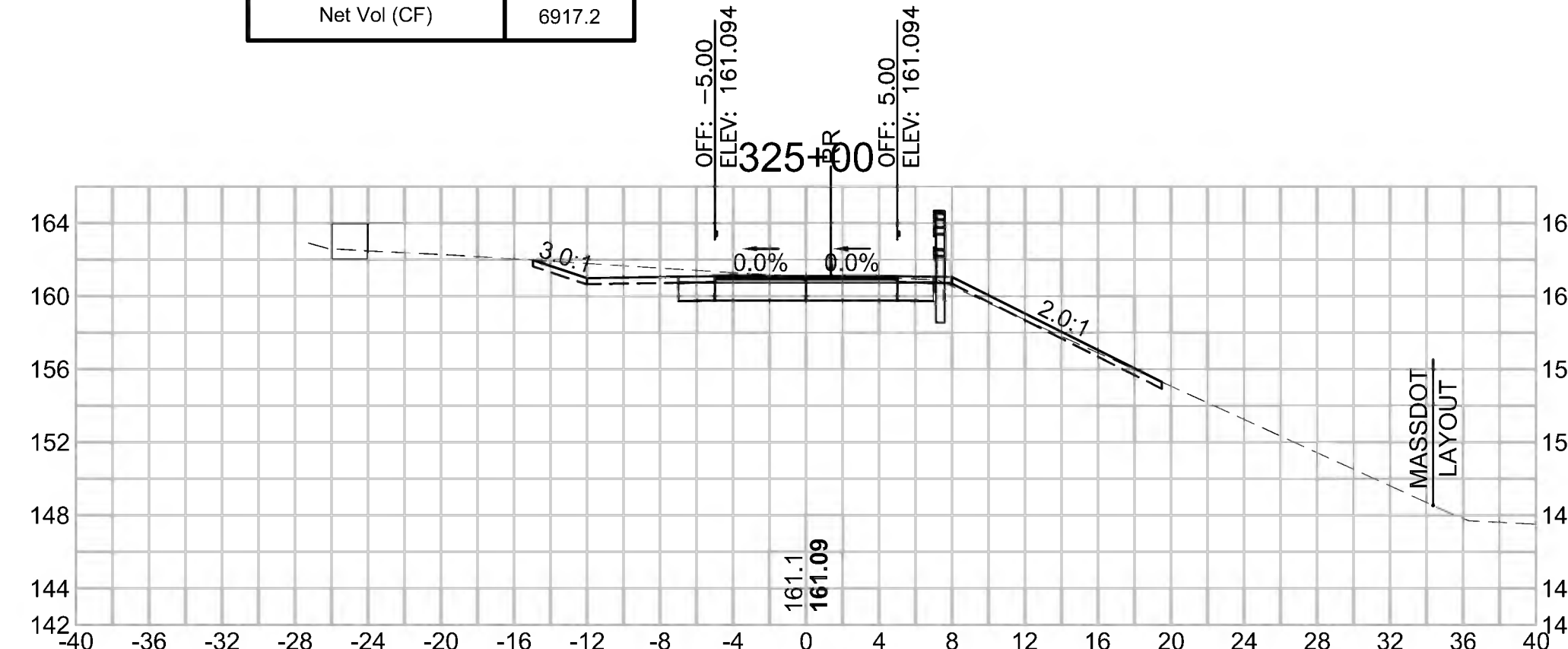
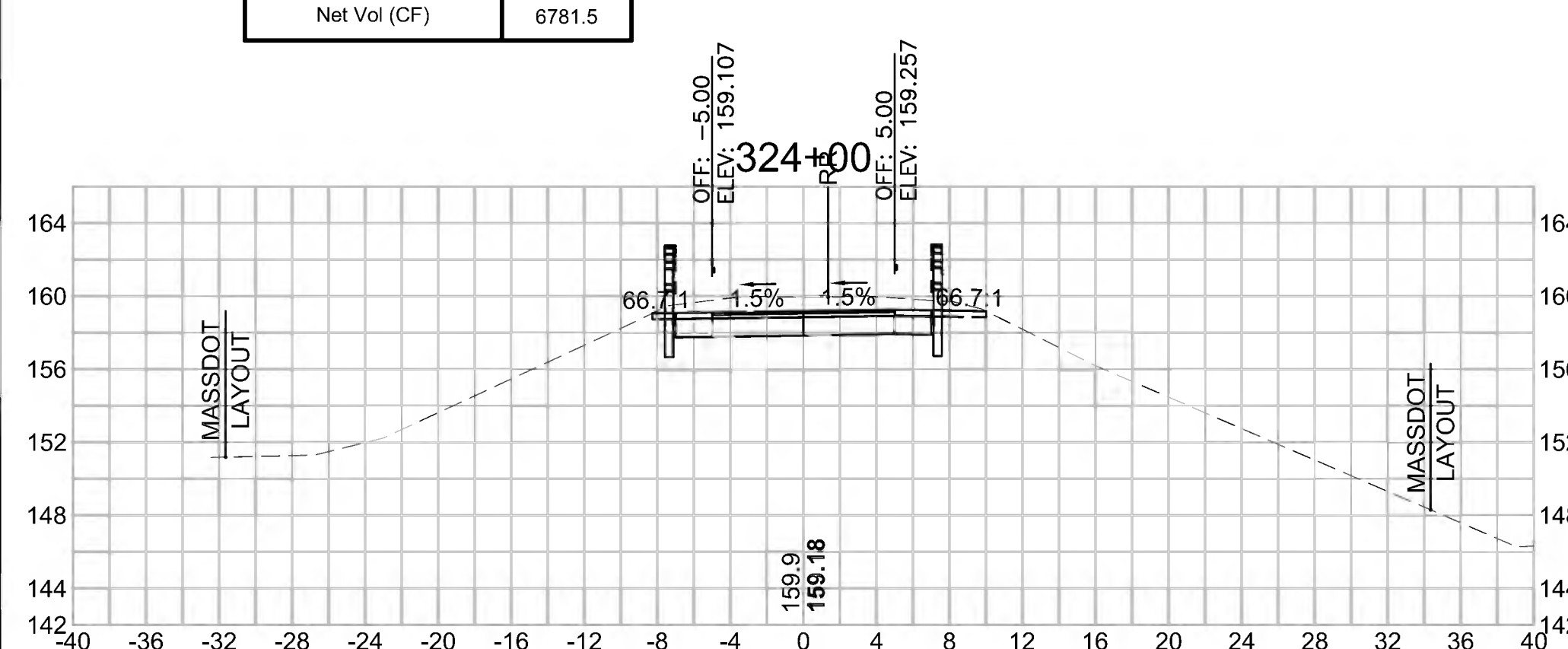

SUDBURY
BRUCE FREEMAN RAIL TRAIL

STATE	FED. AID PROJ. NO.	SHEET NO.	TOTAL SHEETS
MA	XXX-XXXX(XXX)X	299	319

PROJECT FILE NO. 608164

CROSS SECTIONS

18-Feb-2022 608164_XSEC(CROSS SECTION LAYOUTS).DWG

Total Volume at Station 327+50.00

Cut Area (SF)	18.077
Fill Area (SF)	3.265
Cut Vol (CF)	33.9
Fill Vol (CF)	4.2
Cum Cut Vol (CF)	15512.8
Cum Fill Vol (CF)	8448.2
Net Vol (CF)	7064.5

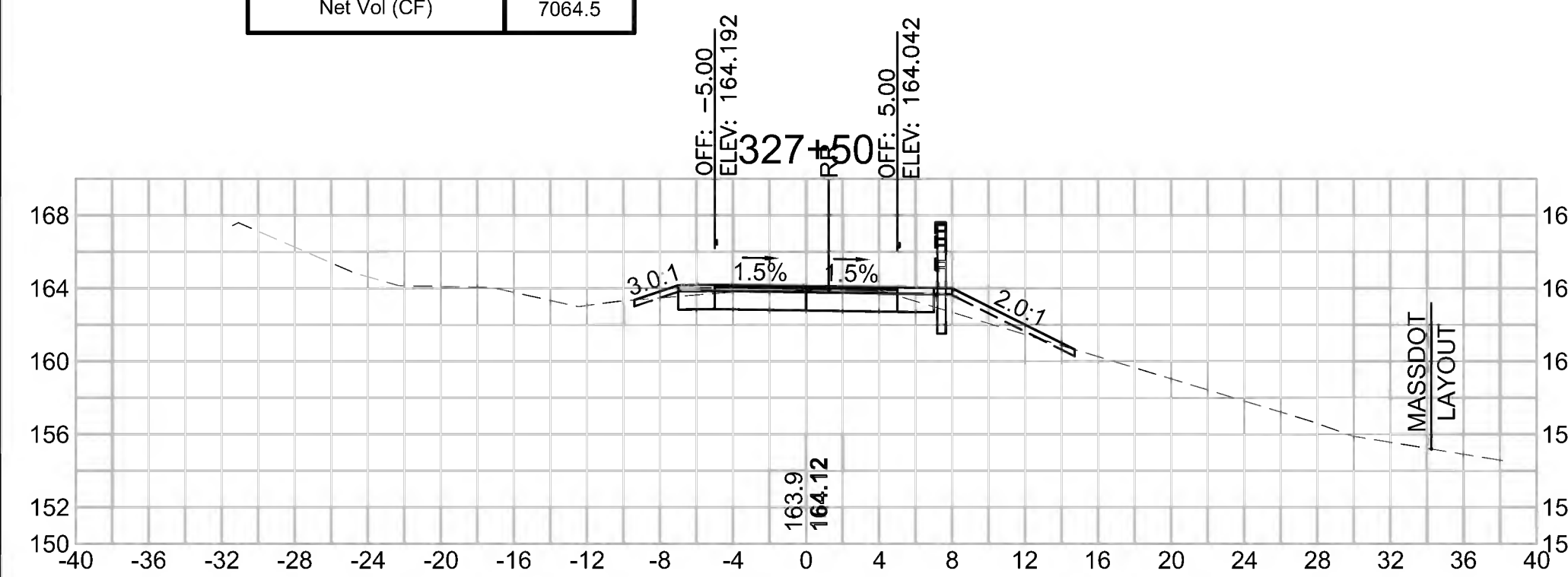

Total Volume at Station 328+50.00

Cut Area (SF)	18.666
Fill Area (SF)	3.588
Cut Vol (CF)	33.0
Fill Vol (CF)	9.1
Cum Cut Vol (CF)	15578.3
Cum Fill Vol (CF)	8466.2
Net Vol (CF)	7112.1

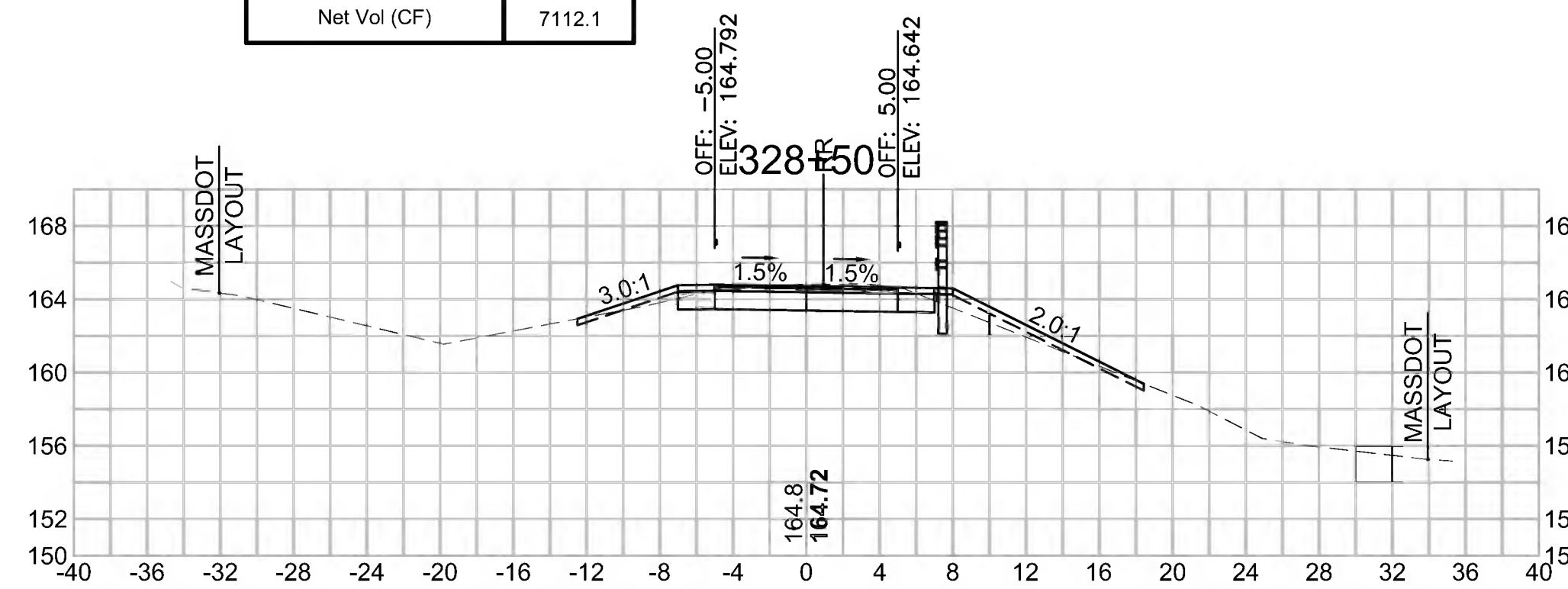

Total Volume at Station 329+50.00

Cut Area (SF)	24.875
Fill Area (SF)	0.622
Cut Vol (CF)	44.8
Fill Vol (CF)	0.7
Cum Cut Vol (CF)	15662.1
Cum Fill Vol (CF)	8470.4
Net Vol (CF)	7191.8

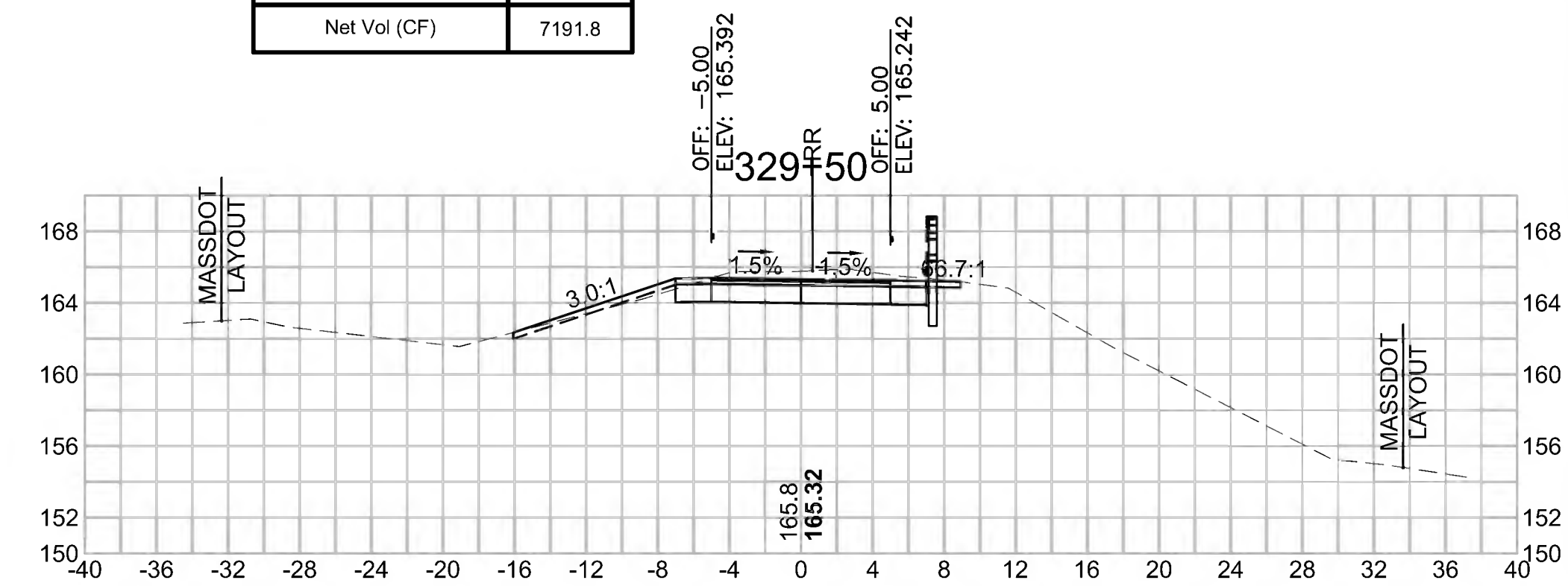

Total Volume at Station 327+00.00

Cut Area (SF)	18.500
Fill Area (SF)	1.258
Cut Vol (CF)	26.7
Fill Vol (CF)	3.7
Cum Cut Vol (CF)	15478.9
Cum Fill Vol (CF)	8444.1
Net Vol (CF)	7034.9

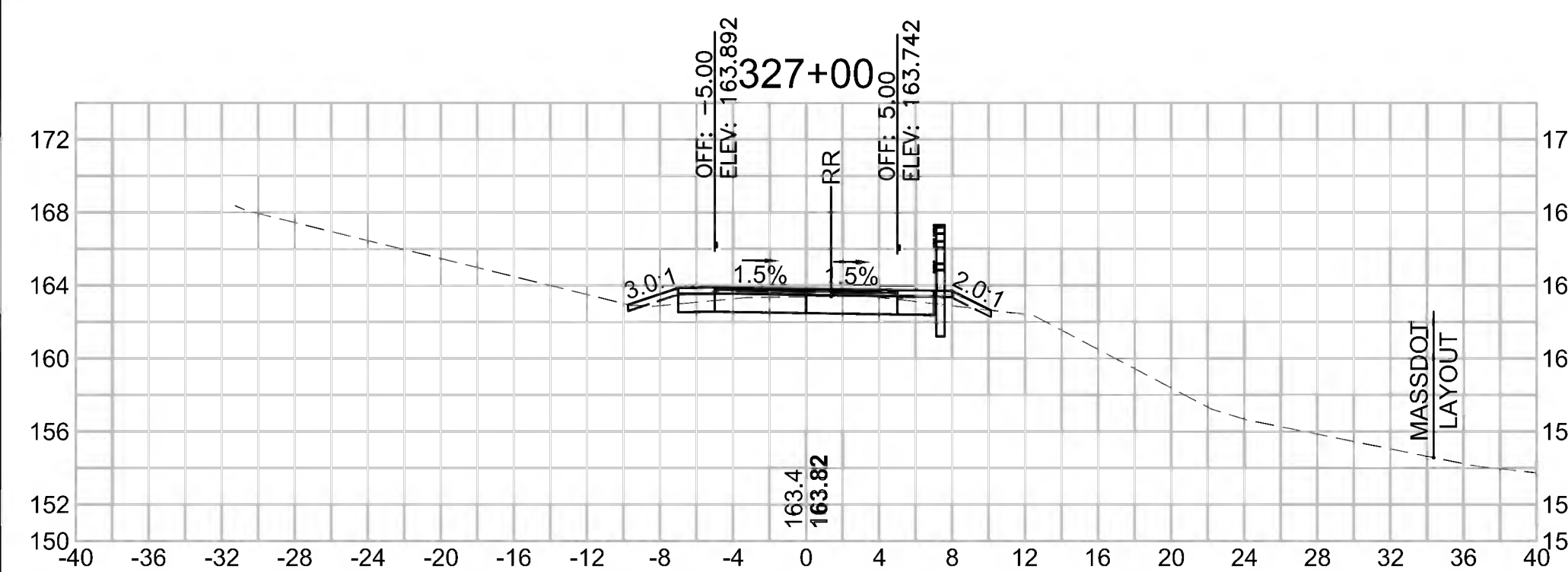

Total Volume at Station 328+00.00

Cut Area (SF)	16.999
Fill Area (SF)	6.252
Cut Vol (CF)	32.5
Fill Vol (CF)	8.8
Cum Cut Vol (CF)	15545.3
Cum Fill Vol (CF)	8457.1
Net Vol (CF)	7088.2

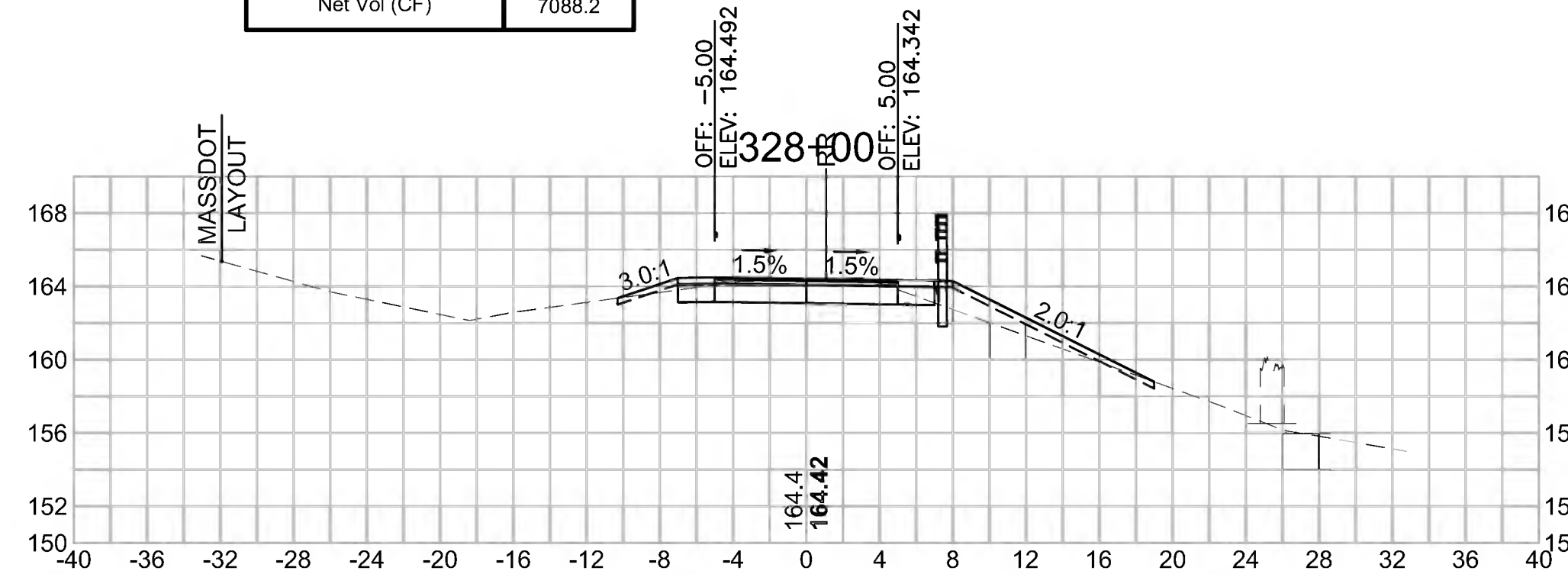

Total Volume at Station 329+00.00

Cut Area (SF)	23.511
Fill Area (SF)	0.168
Cut Vol (CF)	39.1
Fill Vol (CF)	3.5
Cum Cut Vol (CF)	15617.3
Cum Fill Vol (CF)	8469.6
Net Vol (CF)	7147.7

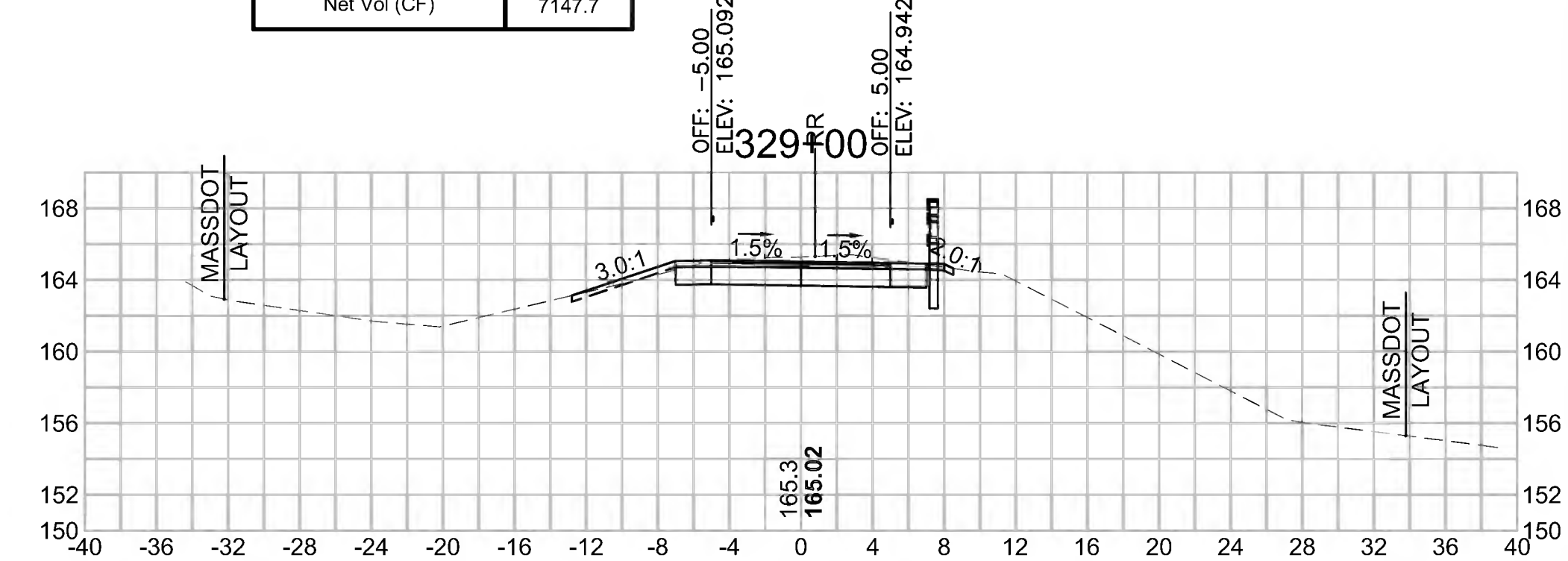

SUDBURY
BRUCE FREEMAN RAIL TRAIL

STATE	FED. AID PROJ. NO.	SHEET NO.	TOTAL SHEETS
MA	XXX-XXXX(XXX)X	300	319

PROJECT FILE NO. 608164

CROSS SECTIONS

608164.XSEC(CROSS SECTION LAYOUTS).DWG 18-Feb-2022

Total Volume at Station 330+50.00

Cut Area (SF)	31.474
Fill Area (SF)	0.000
Cut Vol (CF)	55.7
Fill Vol (CF)	0.0
Cum Cut Vol (CF)	15767.4
Cum Fill Vol (CF)	8471.0
Net Vol (CF)	7296.5

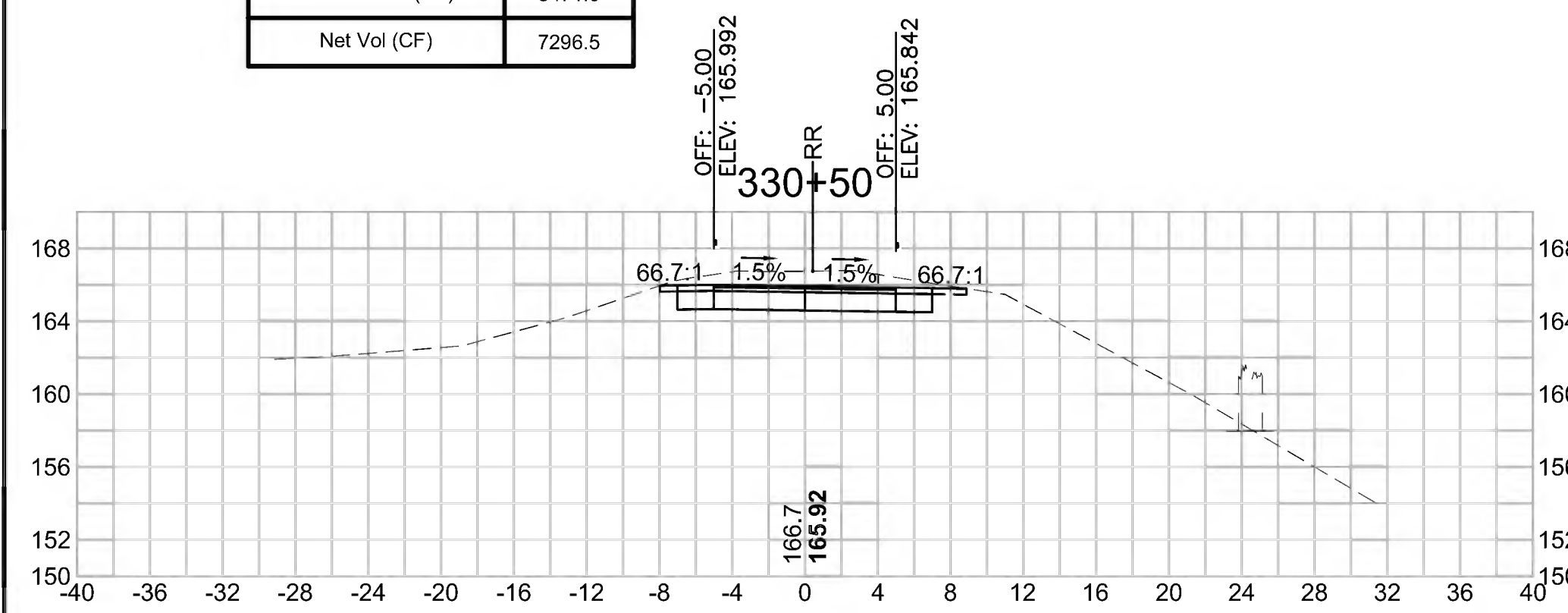

Total Volume at Station 331+50.00

Cut Area (SF)	39.244
Fill Area (SF)	0.000
Cut Vol (CF)	68.2
Fill Vol (CF)	0.0
Cum Cut Vol (CF)	15896.6
Cum Fill Vol (CF)	8471.0
Net Vol (CF)	7425.6

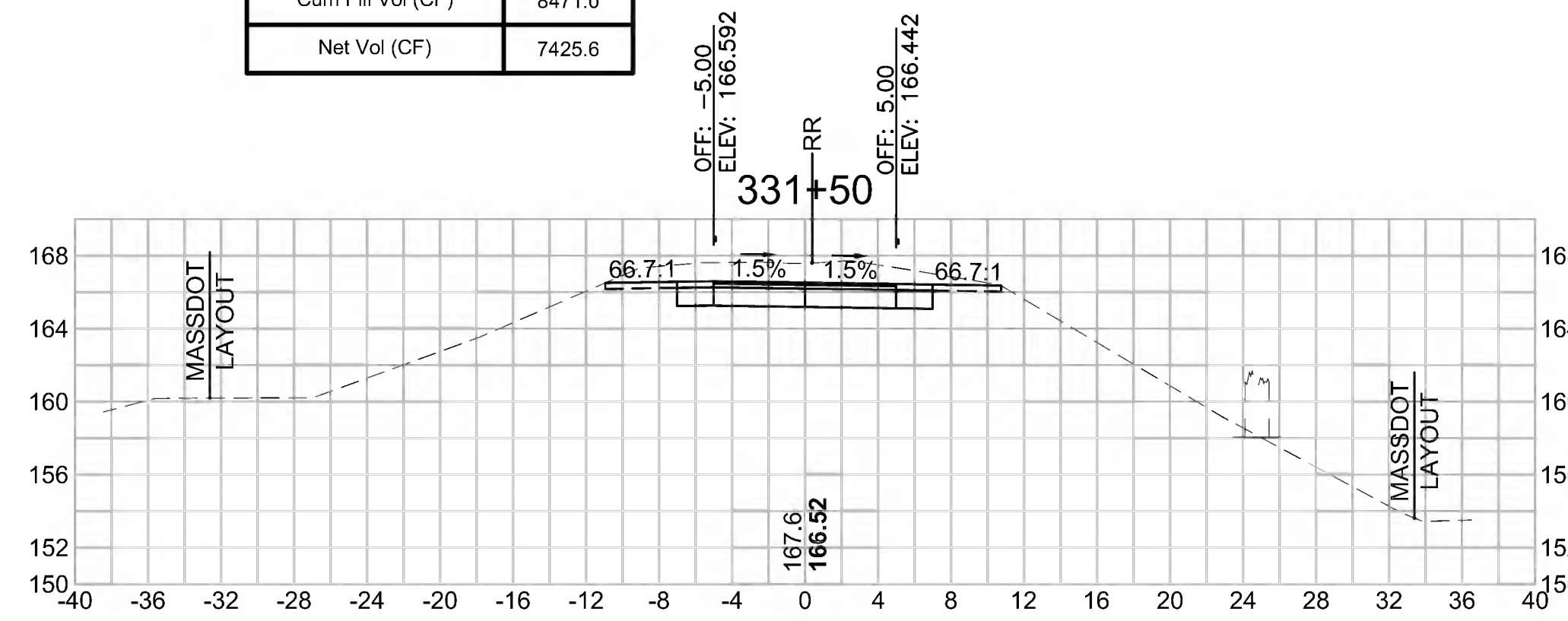

Total Volume at Station 332+50.00

Cut Area (SF)	49.165
Fill Area (SF)	0.634
Cut Vol (CF)	85.6
Fill Vol (CF)	0.6
Cum Cut Vol (CF)	16058.6
Cum Fill Vol (CF)	8471.5
Net Vol (CF)	7587.0

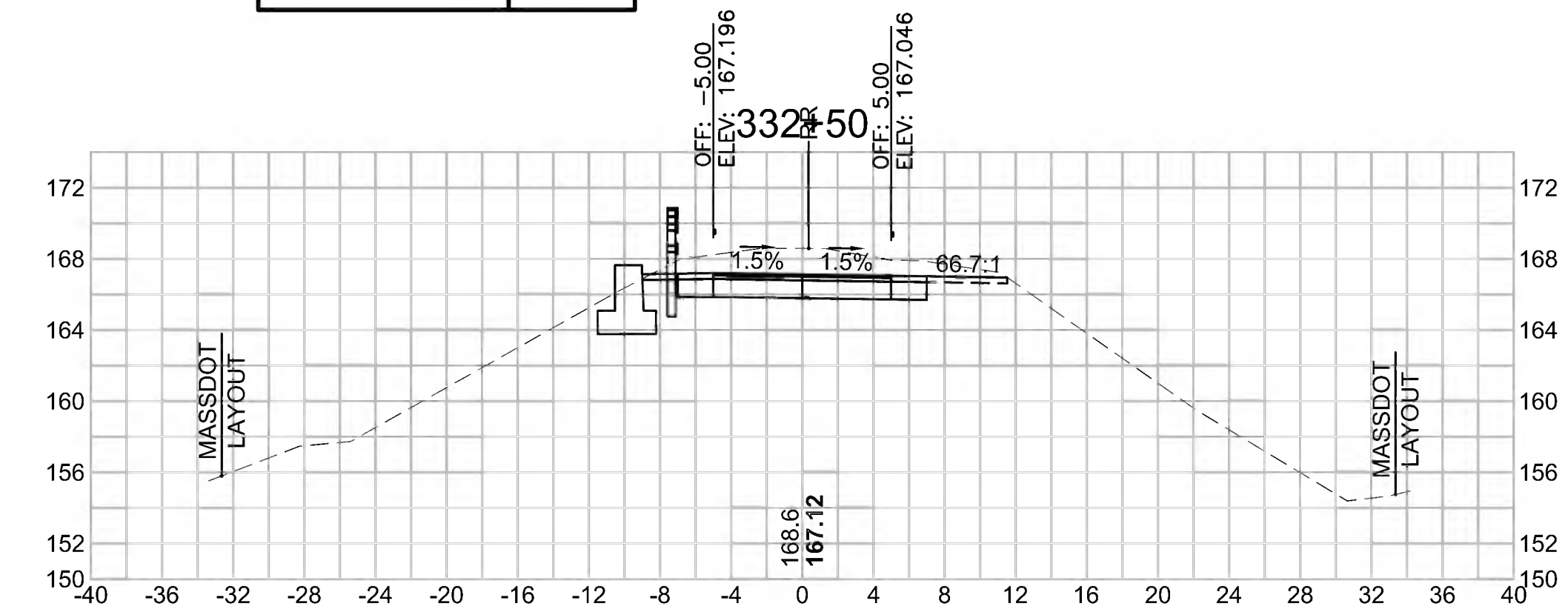

Total Volume at Station 330+00.00

Cut Area (SF)	28.671
Fill Area (SF)	0.000
Cut Vol (CF)	49.6
Fill Vol (CF)	0.6
Cum Cut Vol (CF)	15711.7
Cum Fill Vol (CF)	8471.0
Net Vol (CF)	7240.8

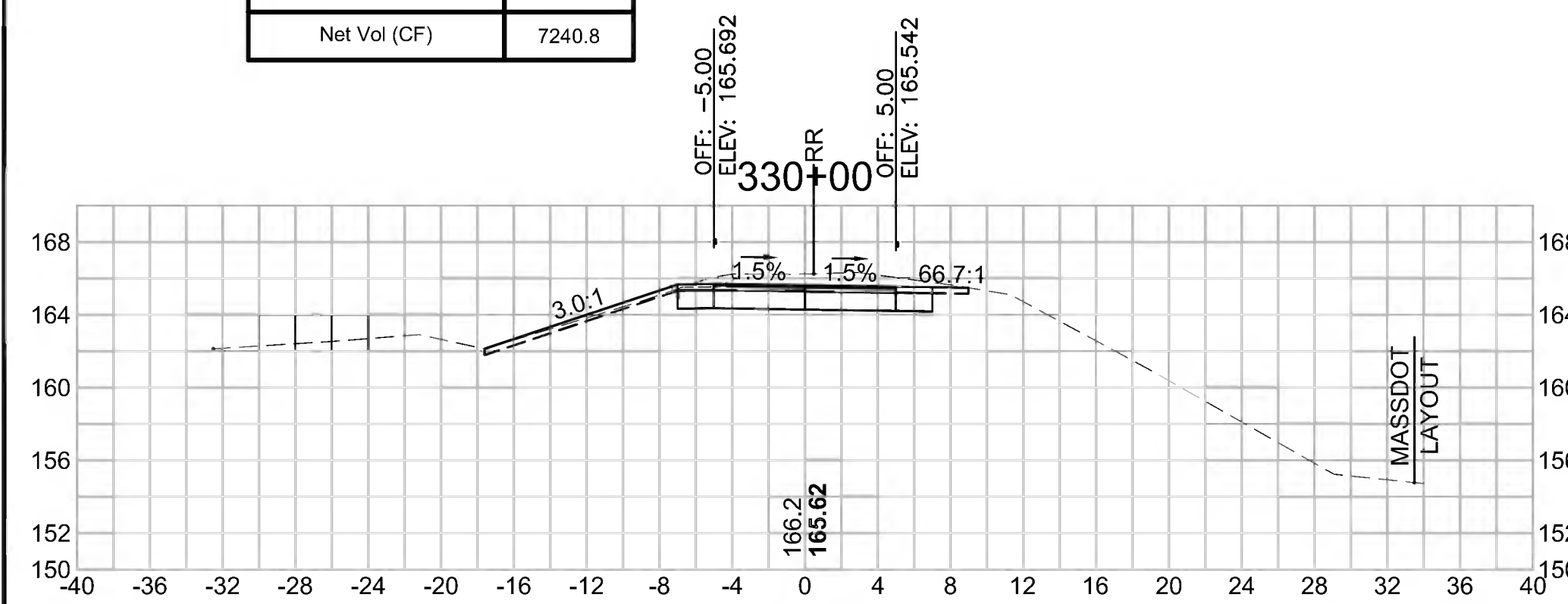

Total Volume at Station 331+00.00

Cut Area (SF)	34.386
Fill Area (SF)	0.000
Cut Vol (CF)	61.0
Fill Vol (CF)	0.0
Cum Cut Vol (CF)	15828.4
Cum Fill Vol (CF)	8471.0
Net Vol (CF)	7357.4

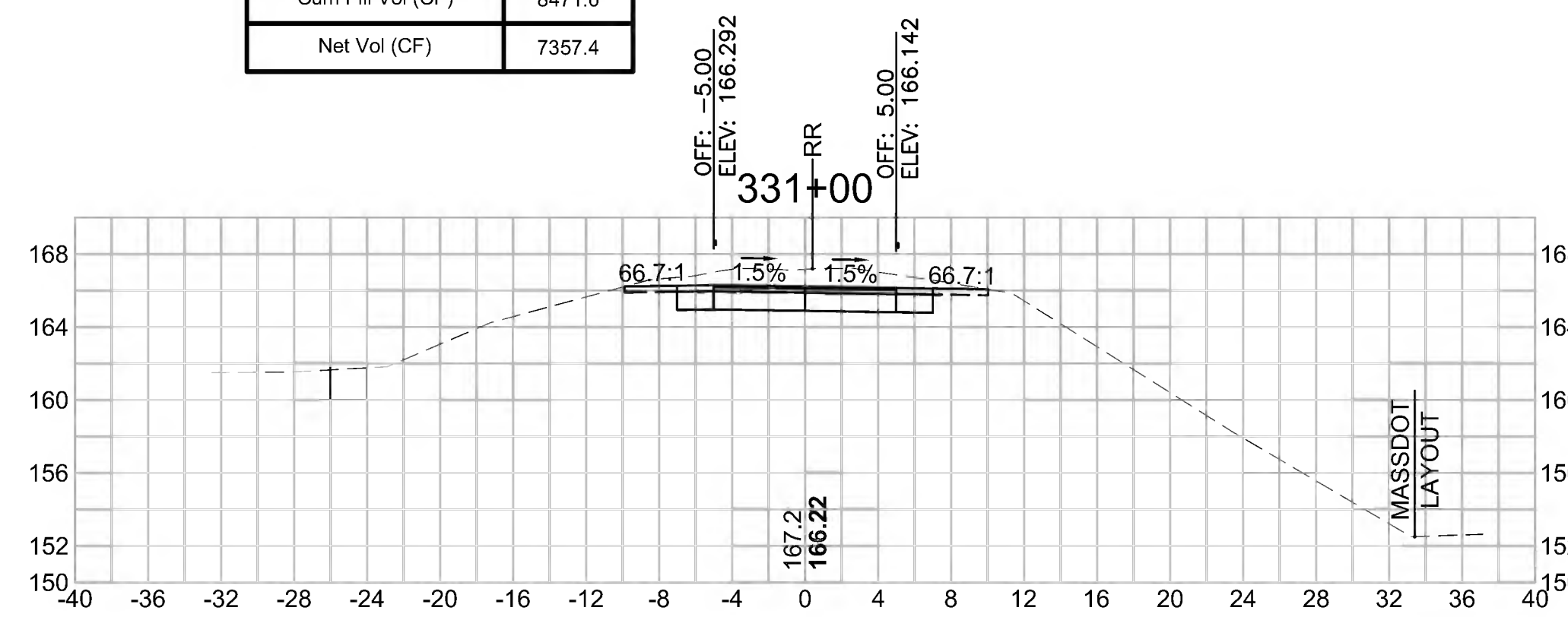

Total Volume at Station 332+00.00

Cut Area (SF)	43.286
Fill Area (SF)	0.000
Cut Vol (CF)	76.4
Fill Vol (CF)	0.0
Cum Cut Vol (CF)	15973.0
Cum Fill Vol (CF)	8471.0
Net Vol (CF)	7502.0

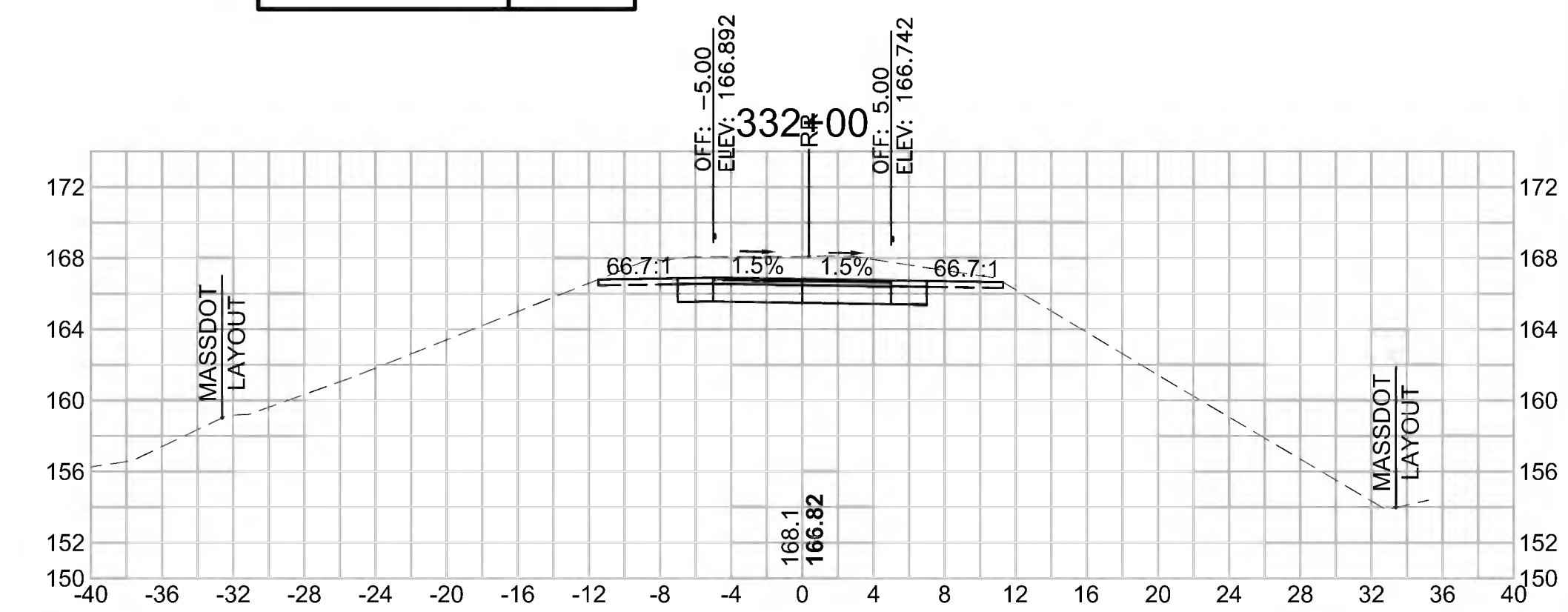

SUDBURY
BRUCE FREEMAN RAIL TRAIL

STATE	FED. AID PROJ. NO.	SHEET NO.	TOTAL SHEETS
MA	XXX-XXX(XXX)X	301	319
PROJECT FILE NO. 608164			

CROSS SECTIONS

18-Feb-2022 608164_XSEC(CROSS SECTION LAYOUTS).DWG

Total Volume at Station 333+50.00

Cut Area (SF)	31.997
Fill Area (SF)	0.000
Cut Vol (CF)	70.8
Fill Vol (CF)	0.0
Cum Cut Vol (CF)	16216.0
Cum Fill Vol (CF)	8472.2
Net Vol (CF)	7743.8

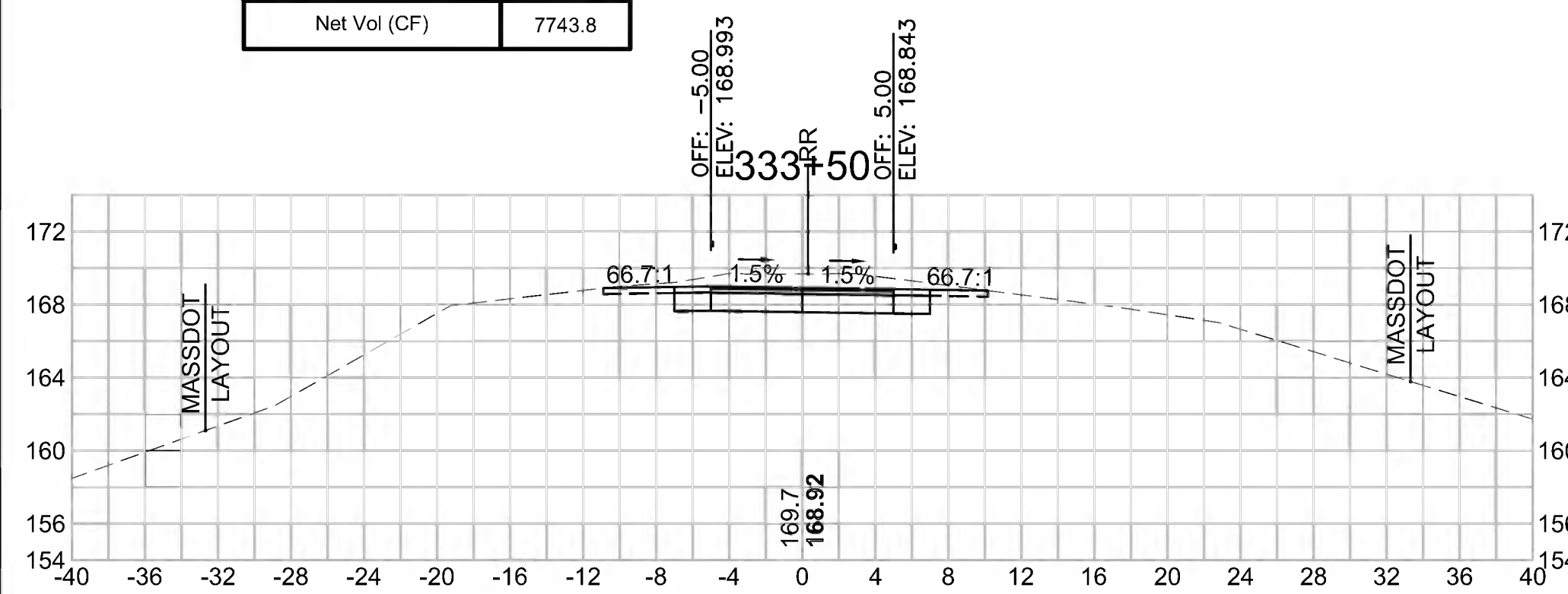

Total Volume at Station 334+50.00

Cut Area (SF)	18.660
Fill Area (SF)	0.046
Cut Vol (CF)	38.3
Fill Vol (CF)	0.3
Cum Cut Vol (CF)	16305.0
Cum Fill Vol (CF)	8472.7
Net Vol (CF)	7832.3

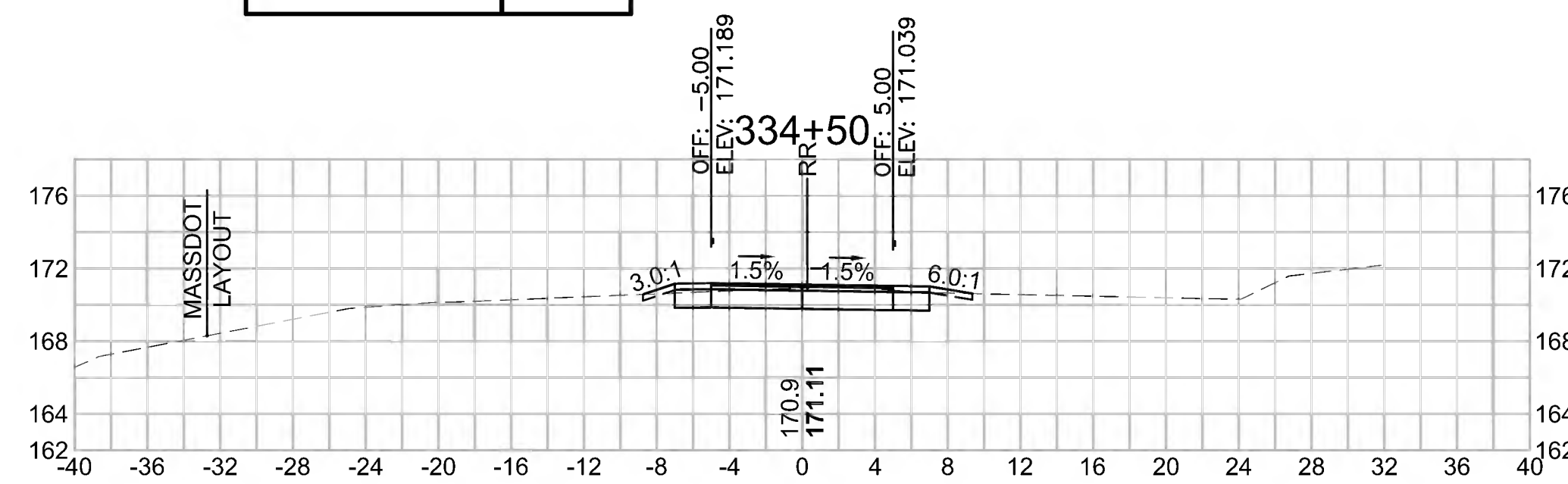

Total Volume at Station 333+00.00

Cut Area (SF)	44.440
Fill Area (SF)	0.040
Cut Vol (CF)	86.7
Fill Vol (CF)	0.6
Cum Cut Vol (CF)	16145.3
Cum Fill Vol (CF)	8472.2
Net Vol (CF)	7673.1

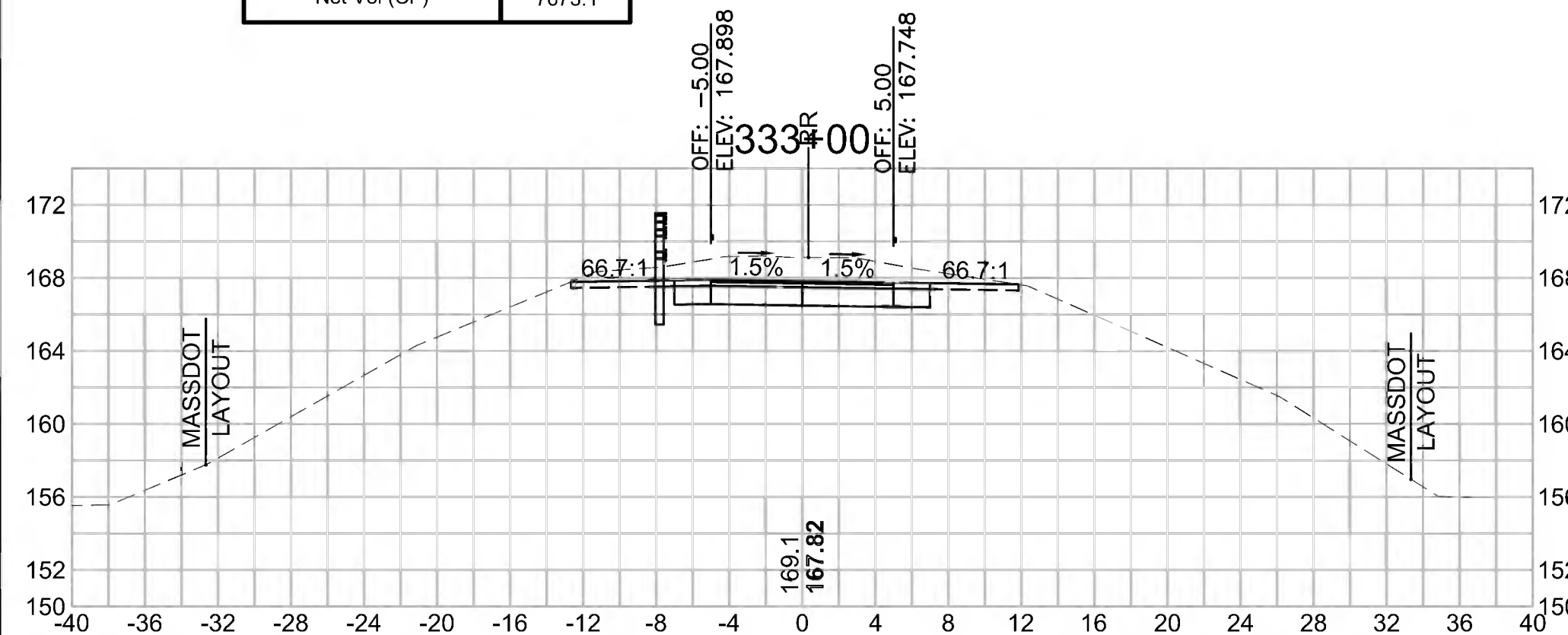

Total Volume at Station 334+00.00

Cut Area (SF)	22.718
Fill Area (SF)	0.248
Cut Vol (CF)	50.7
Fill Vol (CF)	0.2
Cum Cut Vol (CF)	16266.7
Cum Fill Vol (CF)	8472.4
Net Vol (CF)	7794.3

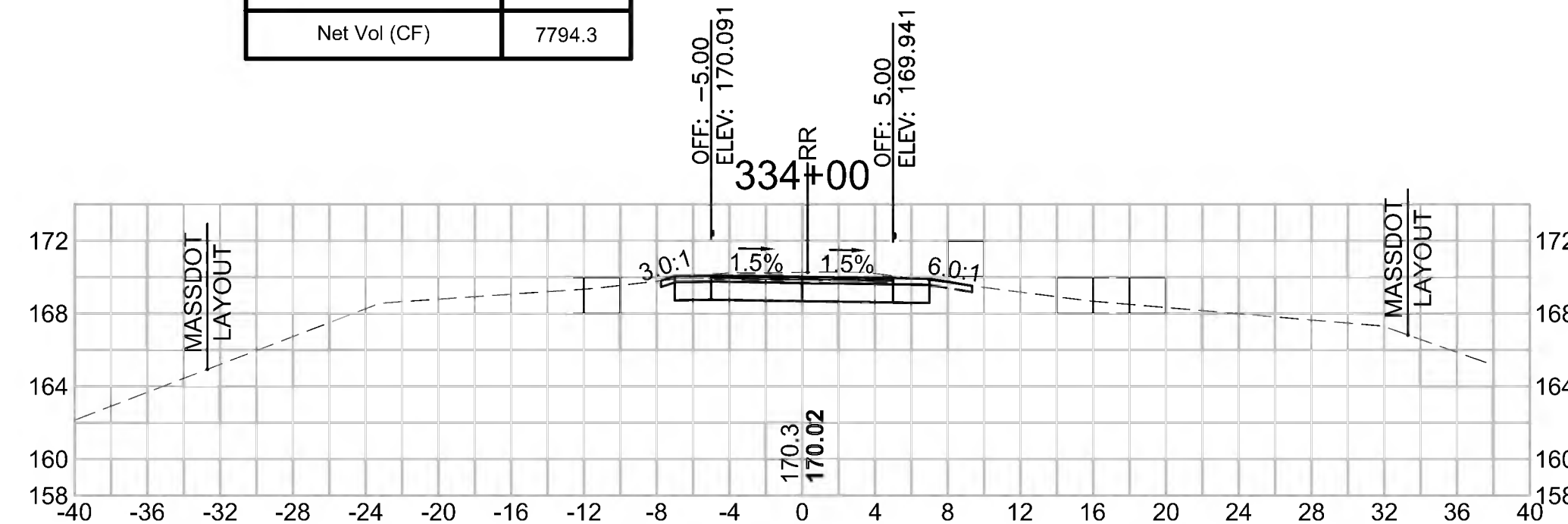

Total Volume at Station 335+00.00

Cut Area (SF)	9.103
Fill Area (SF)	2.279
Cut Vol (CF)	25.7
Fill Vol (CF)	2.2
Cum Cut Vol (CF)	16330.7
Cum Fill Vol (CF)	8474.9
Net Vol (CF)	7855.9

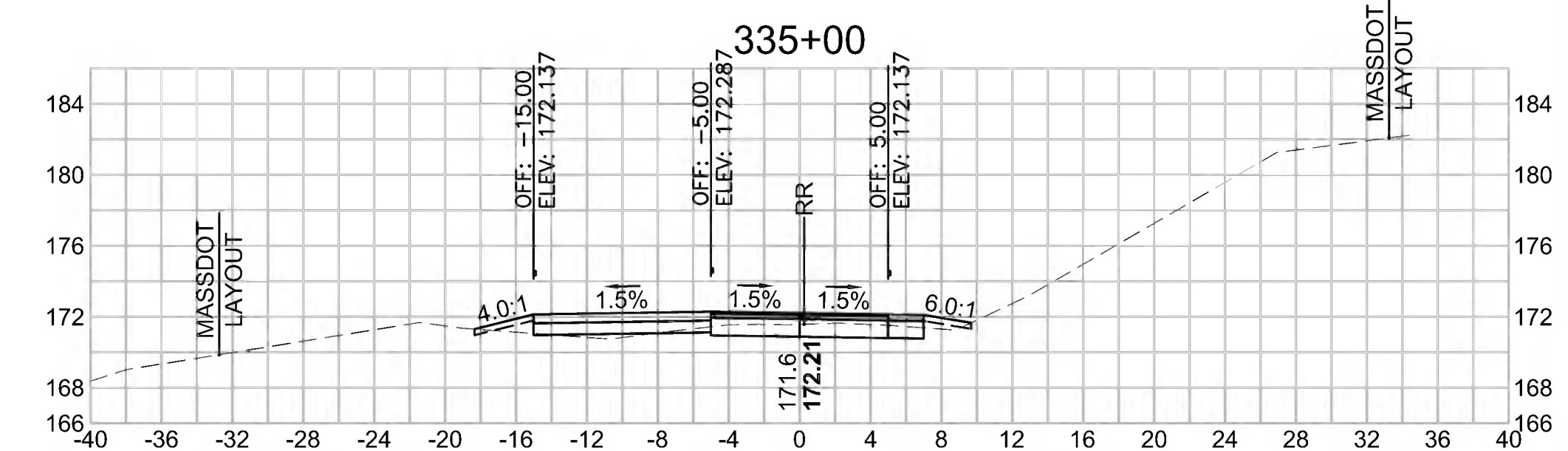

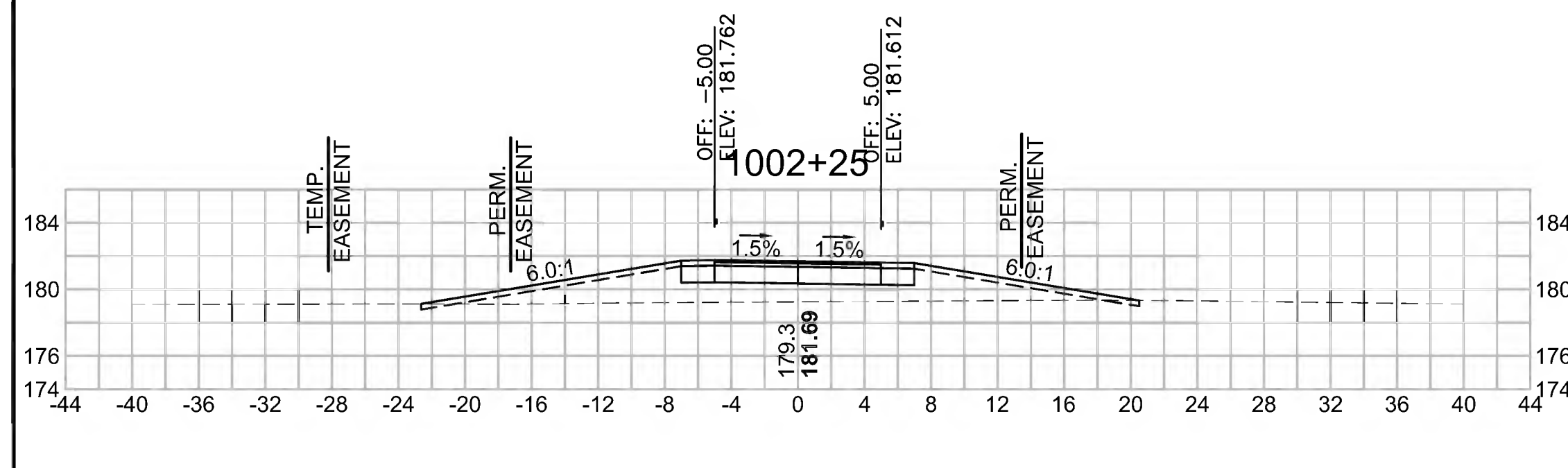

Total Volume at Station 1002+25.00	
Cut Area (SF)	7.878
Fill Area (SF)	41.517
Cut Vol (CF)	8.8
Fill Vol (CF)	27.4
Cum Cut Vol (CF)	120.8
Cum Fill Vol (CF)	39.0
Net Vol (CF)	81.8

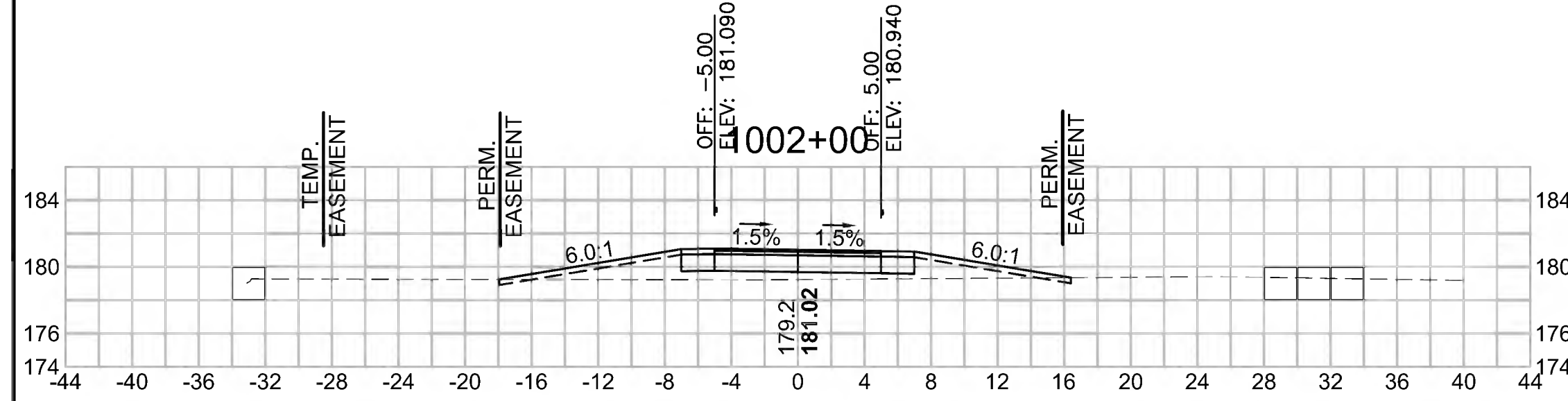

Total Volume at Station 1002+00.00	
Cut Area (SF)	11.225
Fill Area (SF)	17.705
Cut Vol (CF)	13.4
Fill Vol (CF)	9.9
Cum Cut Vol (CF)	112.0
Cum Fill Vol (CF)	11.6
Net Vol (CF)	100.4

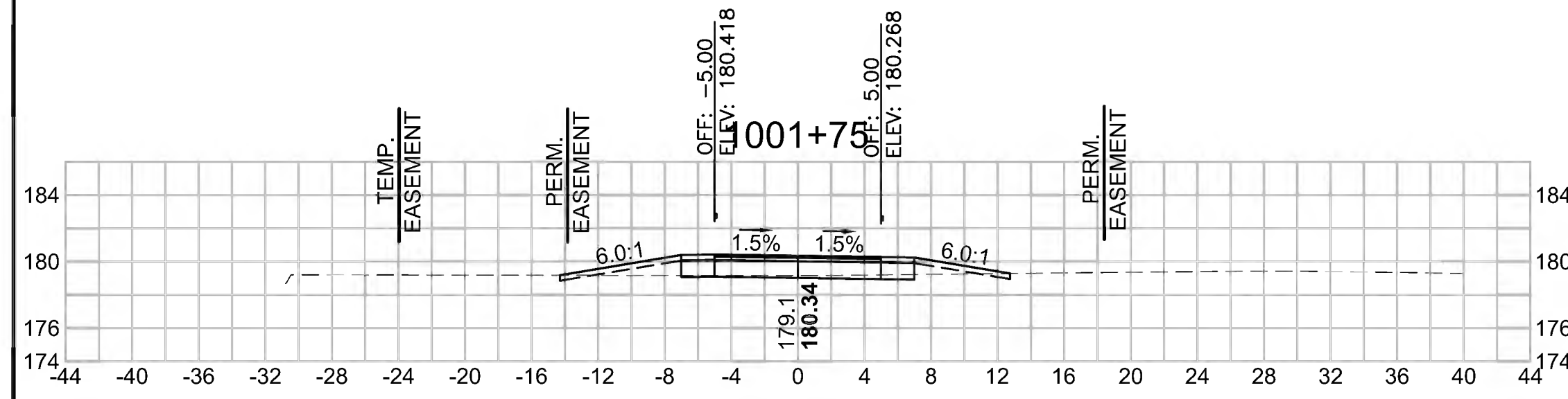

Total Volume at Station 1001+75.00	
Cut Area (SF)	17.683
Fill Area (SF)	3.690
Cut Vol (CF)	22.5
Fill Vol (CF)	1.7
Cum Cut Vol (CF)	98.6
Cum Fill Vol (CF)	1.7
Net Vol (CF)	96.9

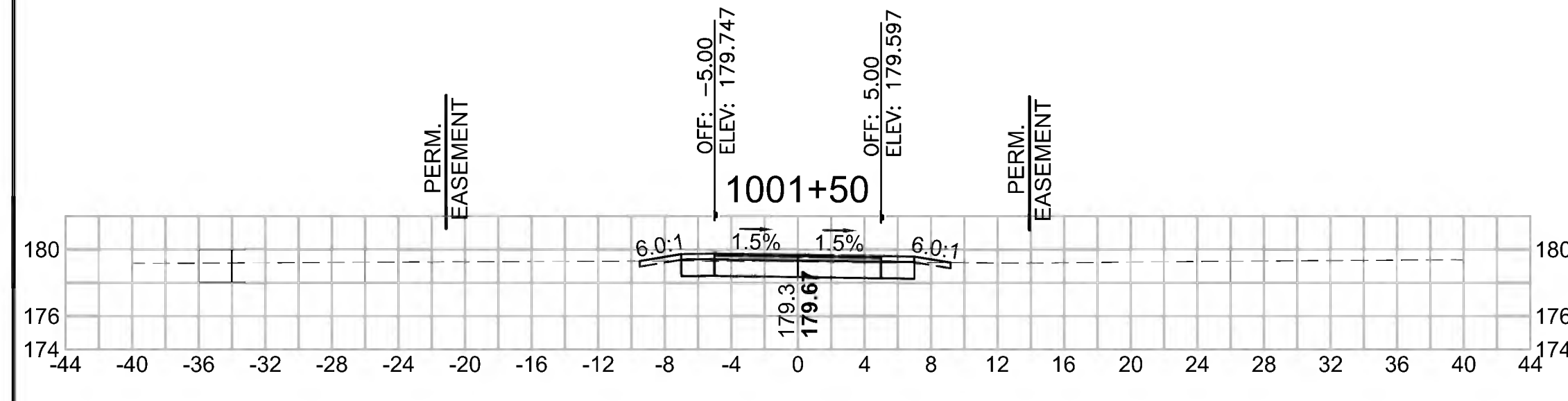

Total Volume at Station 1001+50.00	
Cut Area (SF)	30.927
Fill Area (SF)	0.016
Cut Vol (CF)	33.7
Fill Vol (CF)	0.0
Cum Cut Vol (CF)	76.1
Cum Fill Vol (CF)	0.0
Net Vol (CF)	76.1

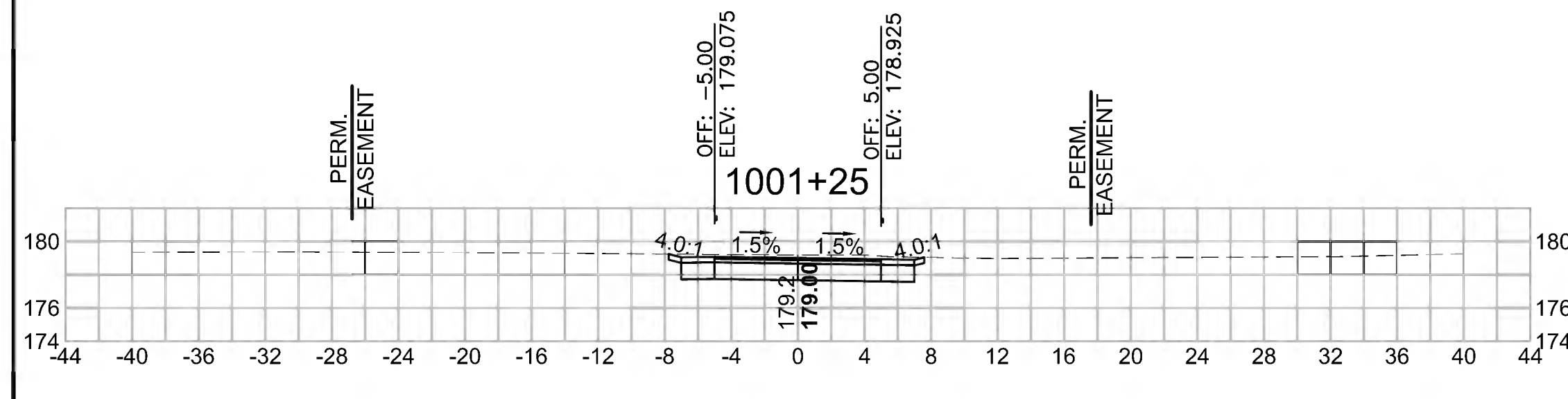

Total Volume at Station 1001+25.00	
Cut Area (SF)	41.878
Fill Area (SF)	0.000
Cut Vol (CF)	42.4
Fill Vol (CF)	0.0
Cum Cut Vol (CF)	42.4
Cum Fill Vol (CF)	0.0
Net Vol (CF)	42.4

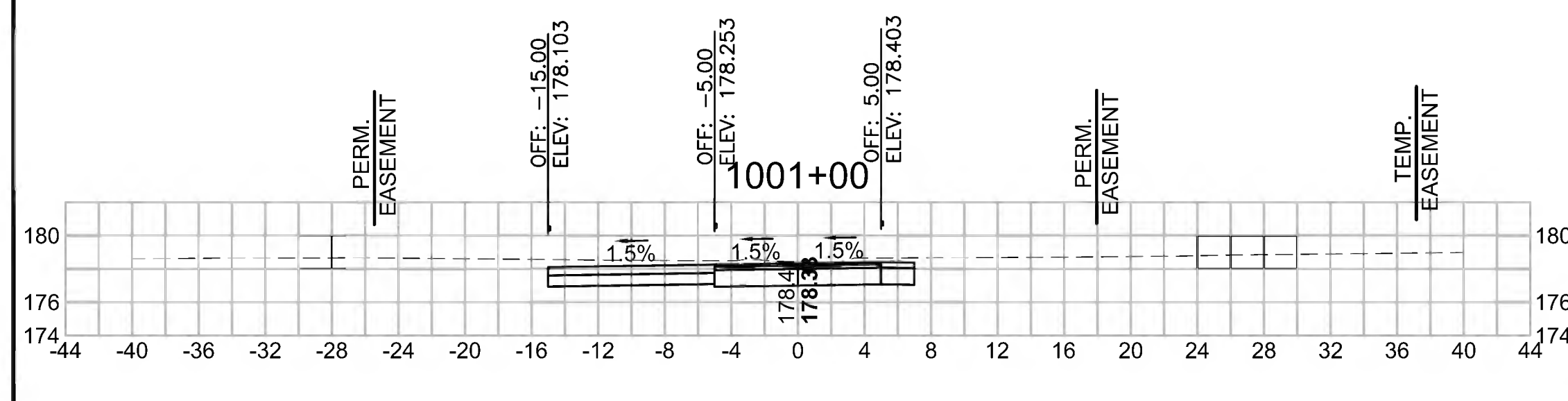

Total Volume at Station 1001+00.00	
Cut Area (SF)	49.693
Fill Area (SF)	0.000
Cut Vol (CF)	0.0
Fill Vol (CF)	0.0
Cum Cut Vol (CF)	0.0
Cum Fill Vol (CF)	0.0
Net Vol (CF)	0.0

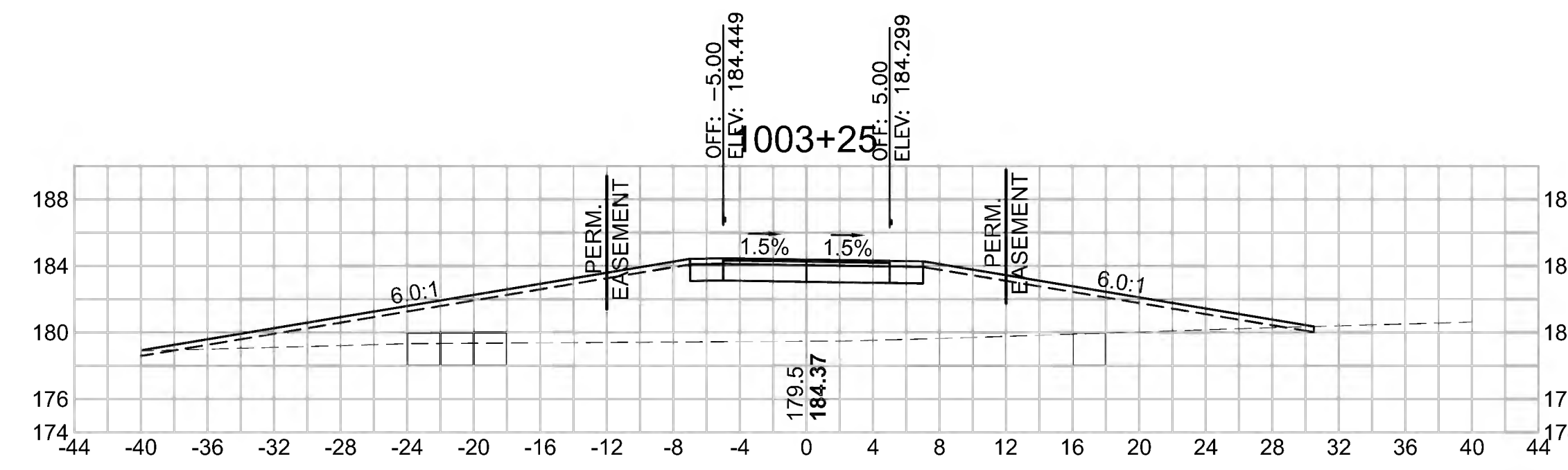

Total Volume at Station 1003+25.00	
Cut Area (SF)	1.211
Fill Area (SF)	166.250
Cut Vol (CF)	1.0
Fill Vol (CF)	146.5
Cum Cut Vol (CF)	131.9
Cum Fill Vol (CF)	464.6
Net Vol (CF)	-332.6

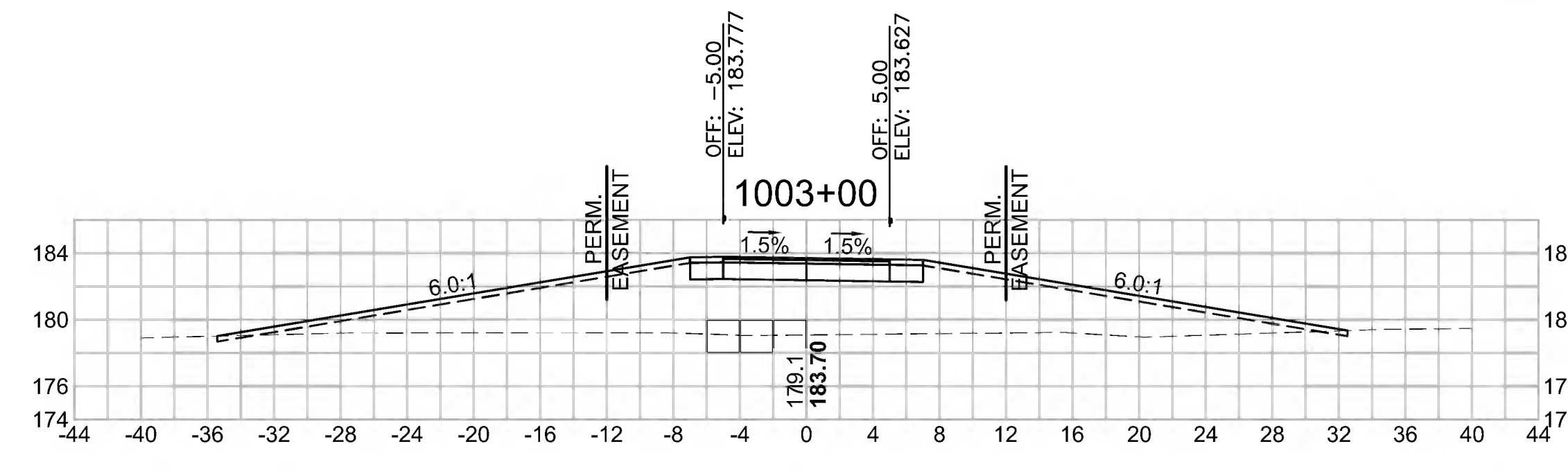

Total Volume at Station 1003+00.00	
Cut Area (SF)	0.999
Fill Area (SF)	150.119
Cut Vol (CF)	1.3
Fill Vol (CF)	124.4
Cum Cut Vol (CF)	130.9
Cum Fill Vol (CF)	318.1
Net Vol (CF)	-187.2

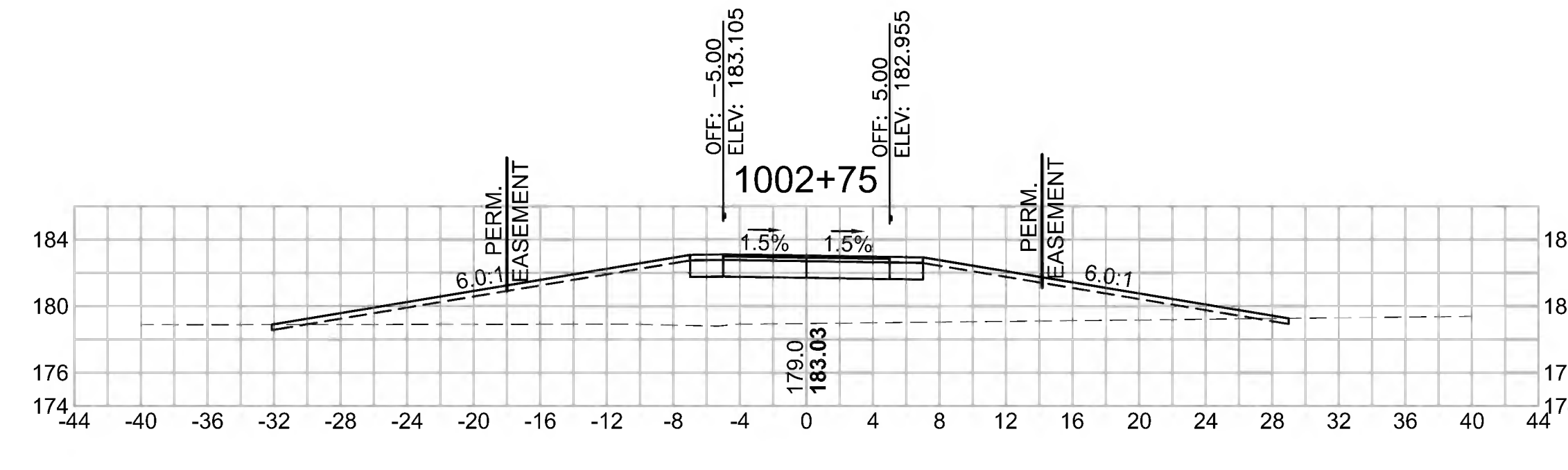

Total Volume at Station 1002+75.00	
Cut Area (SF)	1.852
Fill Area (SF)	118.624
Cut Vol (CF)	3.0
Fill Vol (CF)	95.2
Cum Cut Vol (CF)	129.6
Cum Fill Vol (CF)	193.7
Net Vol (CF)	-64.1

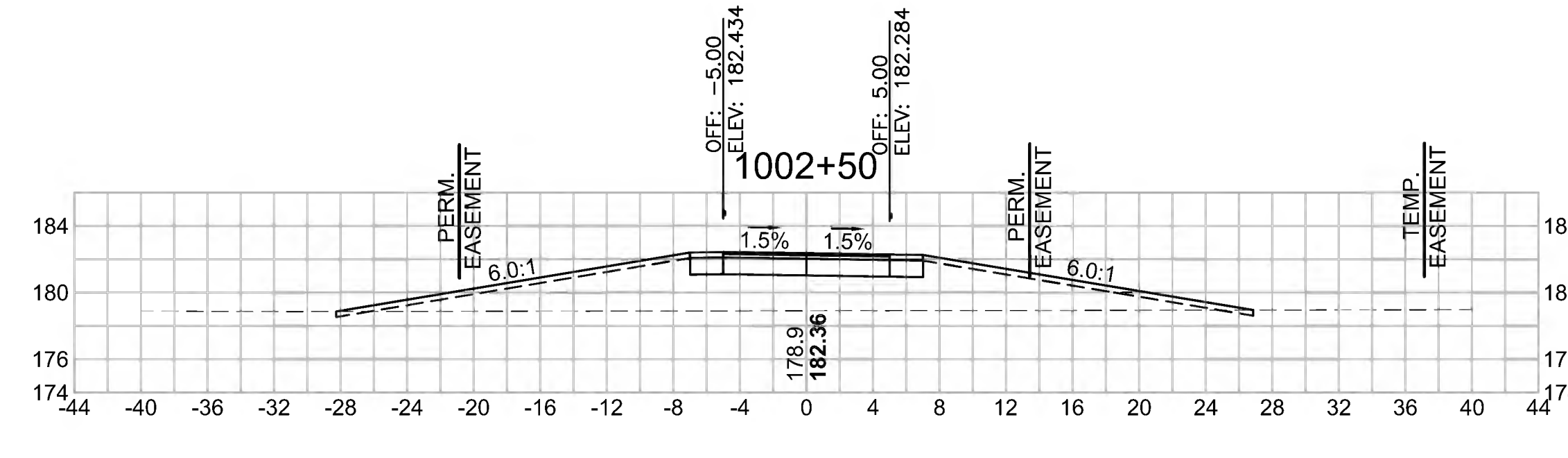

Total Volume at Station 1002+50.00	
Cut Area (SF)	4.605
Fill Area (SF)	86.940
Cut Vol (CF)	5.8
Fill Vol (CF)	59.5
Cum Cut Vol (CF)	126.6
Cum Fill Vol (CF)	98.5
Net Vol (CF)	28.1

**CROSS SECTIONS
DAVIS FIELD ACCESS PATH**

Total Volume at Station 1101+50.00	
Cut Area (SF)	12.344
Fill Area (SF)	9.860
Cut Vol (CF)	23.6
Fill Vol (CF)	9.1
Cum Cut Vol (CF)	45.0
Cum Fill Vol (CF)	9.5
Net Vol (CF)	35.6

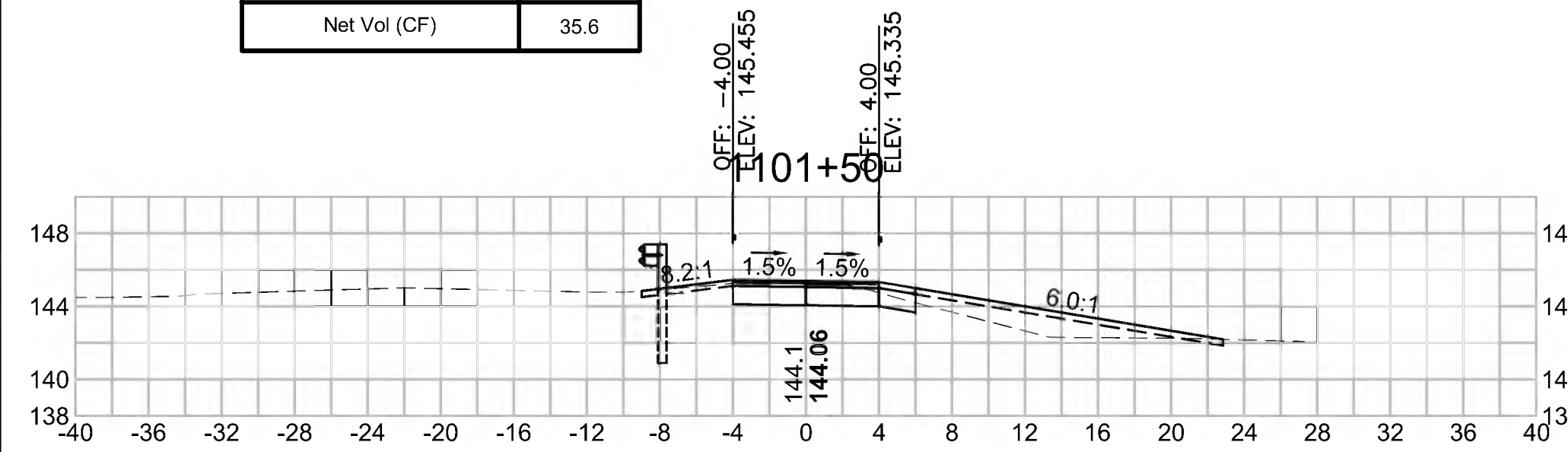

Total Volume at Station 1103+00.00	
Cut Area (SF)	11.283
Fill Area (SF)	5.526
Cut Vol (CF)	22.2
Fill Vol (CF)	7.1
Cum Cut Vol (CF)	124.4
Cum Fill Vol (CF)	34.4
Net Vol (CF)	90.1



Total Volume at Station 1104+50.00	
Cut Area (SF)	10.903
Fill Area (SF)	0.099
Cut Vol (CF)	19.2
Fill Vol (CF)	0.3
Cum Cut Vol (CF)	178.0
Cum Fill Vol (CF)	54.0
Net Vol (CF)	124.1

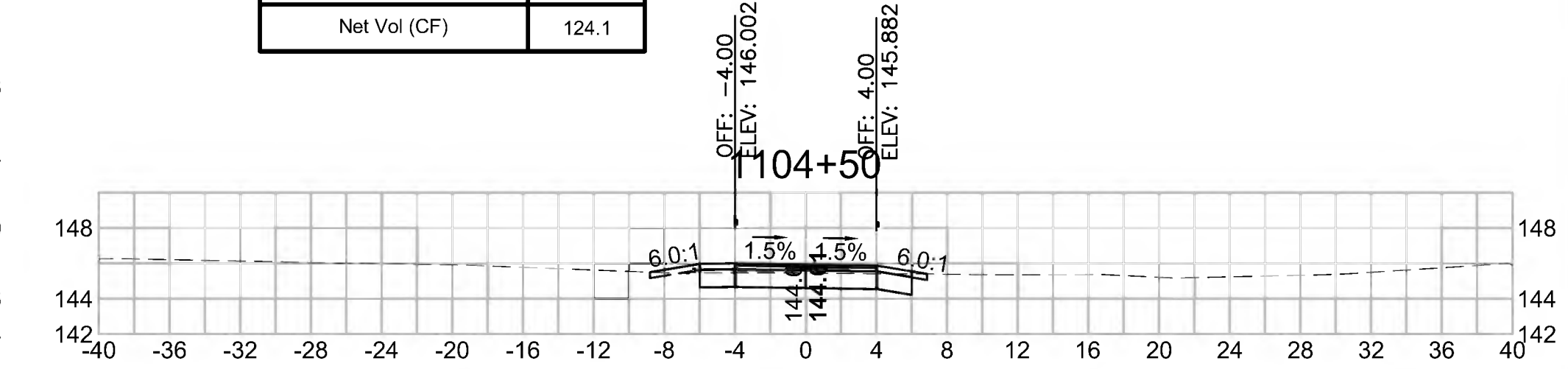

Total Volume at Station 1101+00.00	
Cut Area (SF)	13.171
Fill Area (SF)	0.000
Cut Vol (CF)	21.4
Fill Vol (CF)	0.3
Cum Cut Vol (CF)	21.4
Cum Fill Vol (CF)	0.3
Net Vol (CF)	21.1

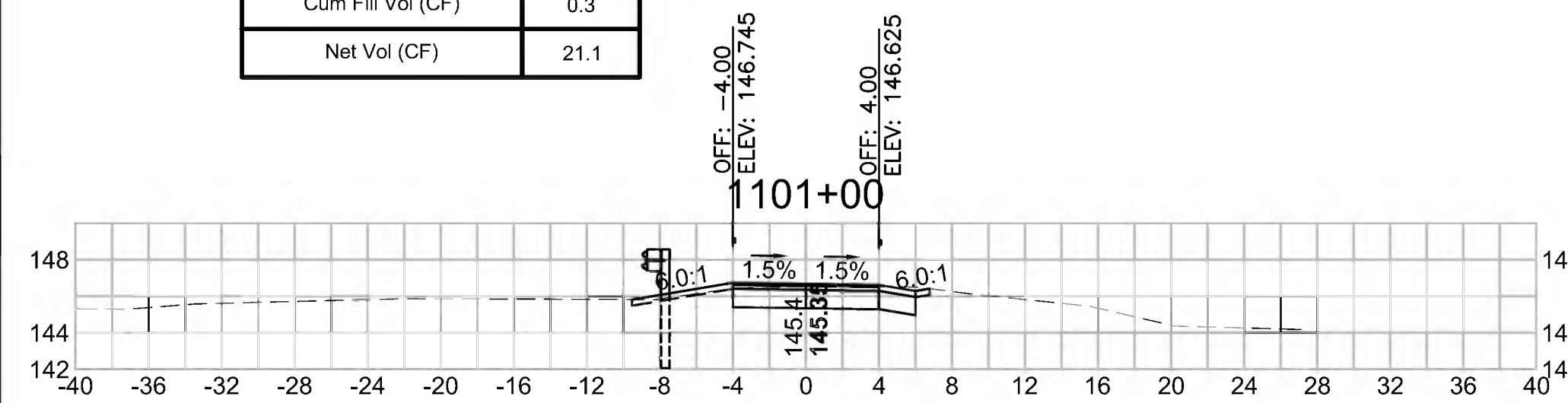

Total Volume at Station 1102+50.00	
Cut Area (SF)	12.683
Fill Area (SF)	2.123
Cut Vol (CF)	28.8
Fill Vol (CF)	5.3
Cum Cut Vol (CF)	102.2
Cum Fill Vol (CF)	27.3
Net Vol (CF)	75.0

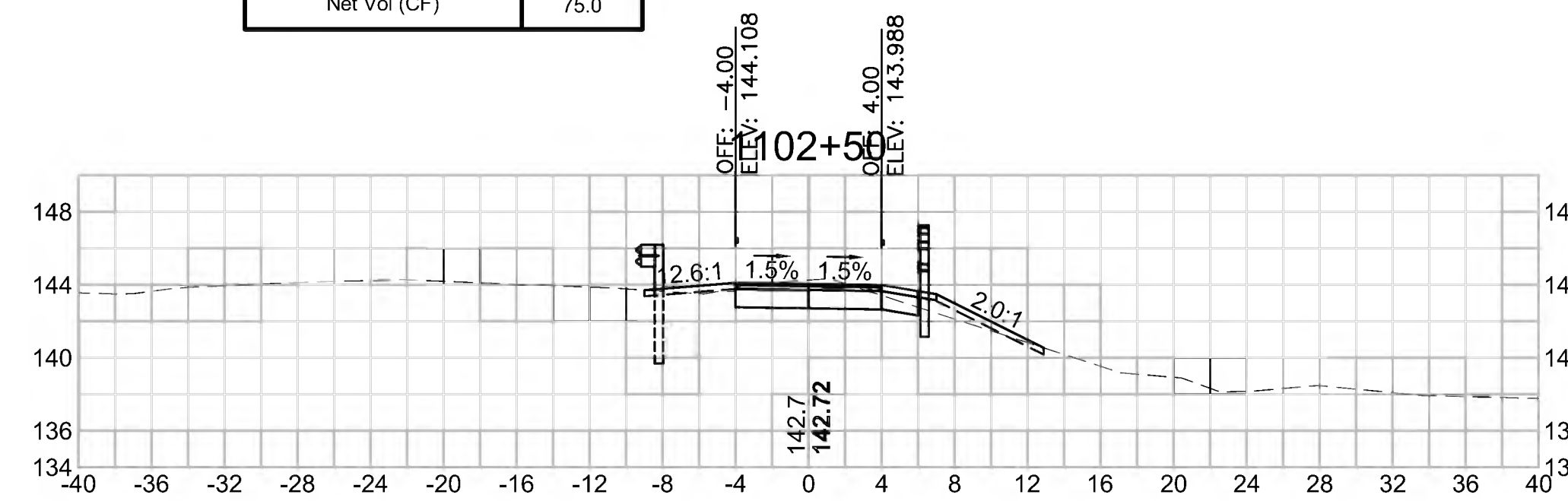

Total Volume at Station 1104+00.00	
Cut Area (SF)	9.816
Fill Area (SF)	0.185
Cut Vol (CF)	16.5
Fill Vol (CF)	7.2
Cum Cut Vol (CF)	158.9
Cum Fill Vol (CF)	53.7
Net Vol (CF)	105.2

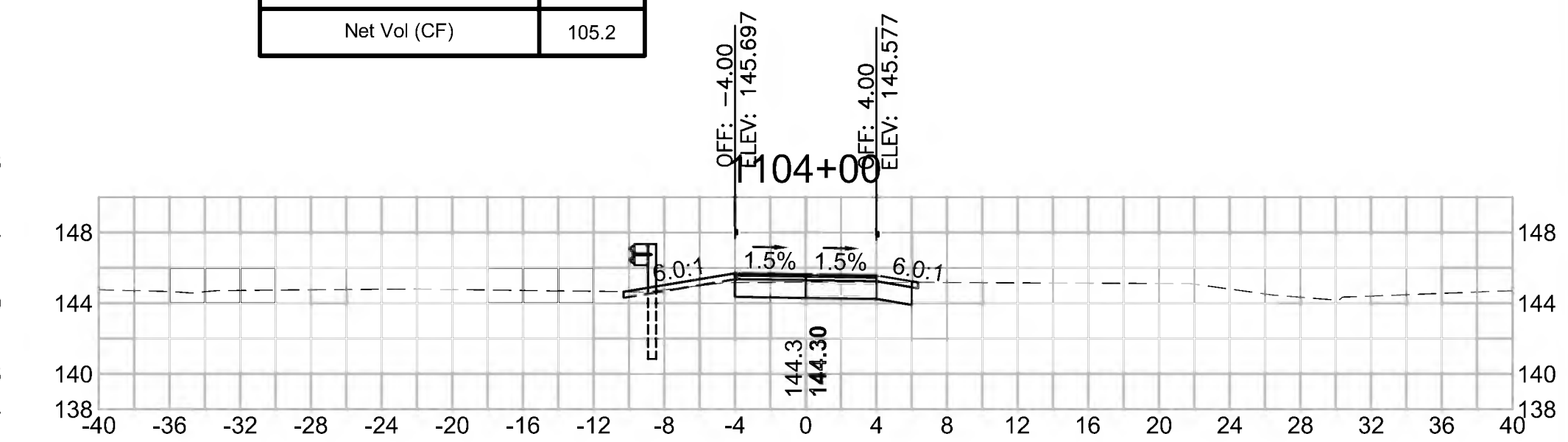

Total Volume at Station 1100+50.00	
Cut Area (SF)	9.964
Fill Area (SF)	0.368
Cut Vol (CF)	0.0
Fill Vol (CF)	0.0
Cum Cut Vol (CF)	0.0
Cum Fill Vol (CF)	0.0
Net Vol (CF)	0.0

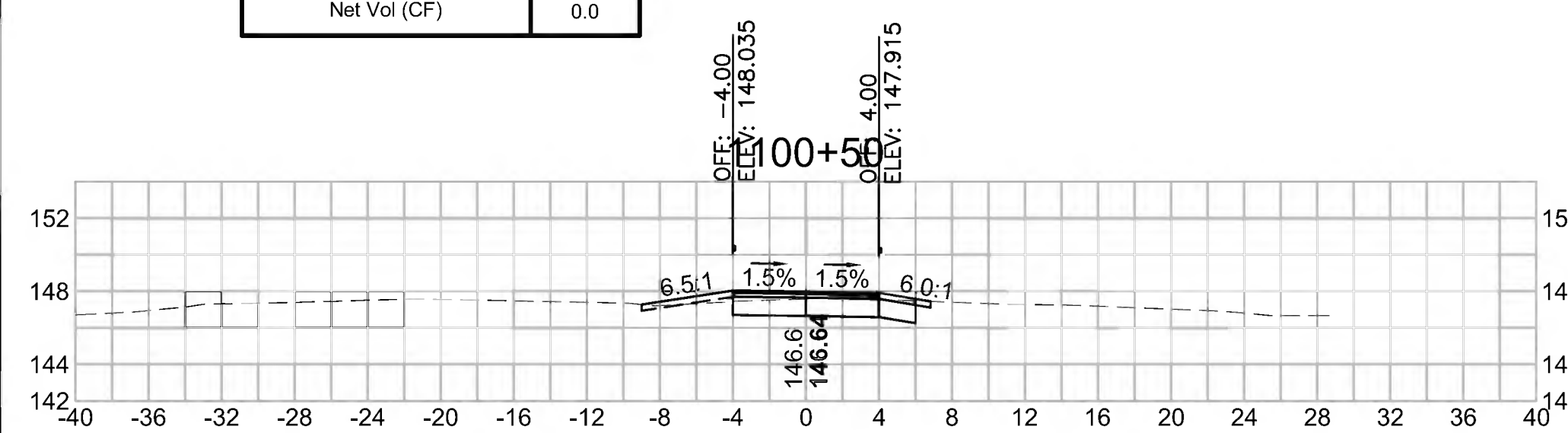

Total Volume at Station 1102+00.00	
Cut Area (SF)	18.374
Fill Area (SF)	3.620
Cut Vol (CF)	28.4
Fill Vol (CF)	12.5
Cum Cut Vol (CF)	73.5
Cum Fill Vol (CF)	22.0
Net Vol (CF)	51.5

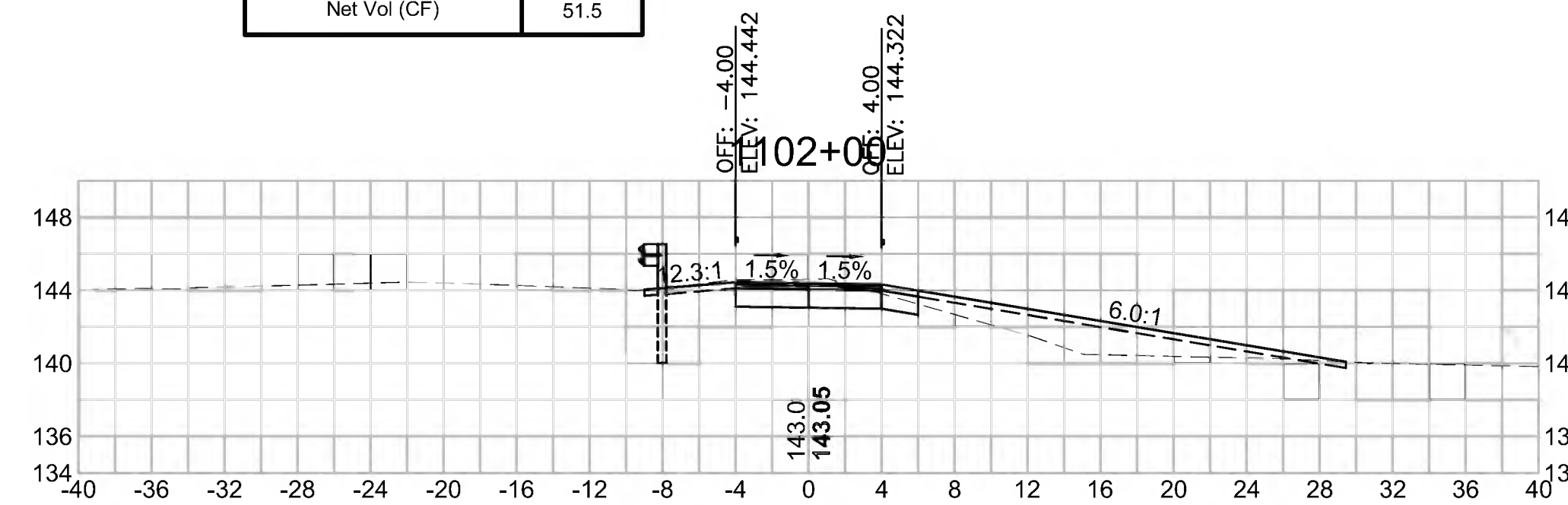

Total Volume at Station 1103+50.00	
Cut Area (SF)	8.037
Fill Area (SF)	7.586
Cut Vol (CF)	17.9
Fill Vol (CF)	12.1
Cum Cut Vol (CF)	142.3
Cum Fill Vol (CF)	46.5
Net Vol (CF)	95.8

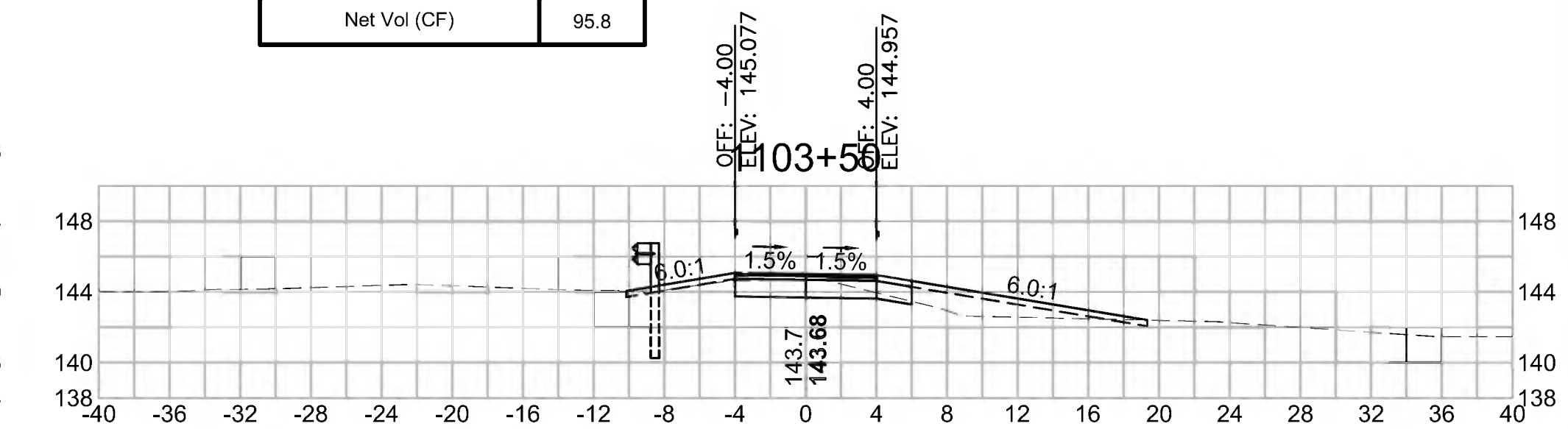

SUDBURY
BRUCE FREEMAN RAIL TRAIL

STATE	FED. AID PROJ. NO.	SHEET NO.	TOTAL SHEETS
MA	XXX-XXXX(XXX)X	304	319
PROJECT FILE NO. 608164			

CROSS SECTIONS
DAVIS FIELD ACCESS PATH

18-Feb-2022
608164_XSEC(CROSS SECTION LAYOUTS).DWG

Total Volume at Station 1106+00.00	
Cut Area (SF)	13.425
Fill Area (SF)	0.000
Cut Vol (CF)	26.2
Fill Vol (CF)	0.0
Cum Cut Vol (CF)	248.7
Cum Fill Vol (CF)	54.1
Net Vol (CF)	194.6

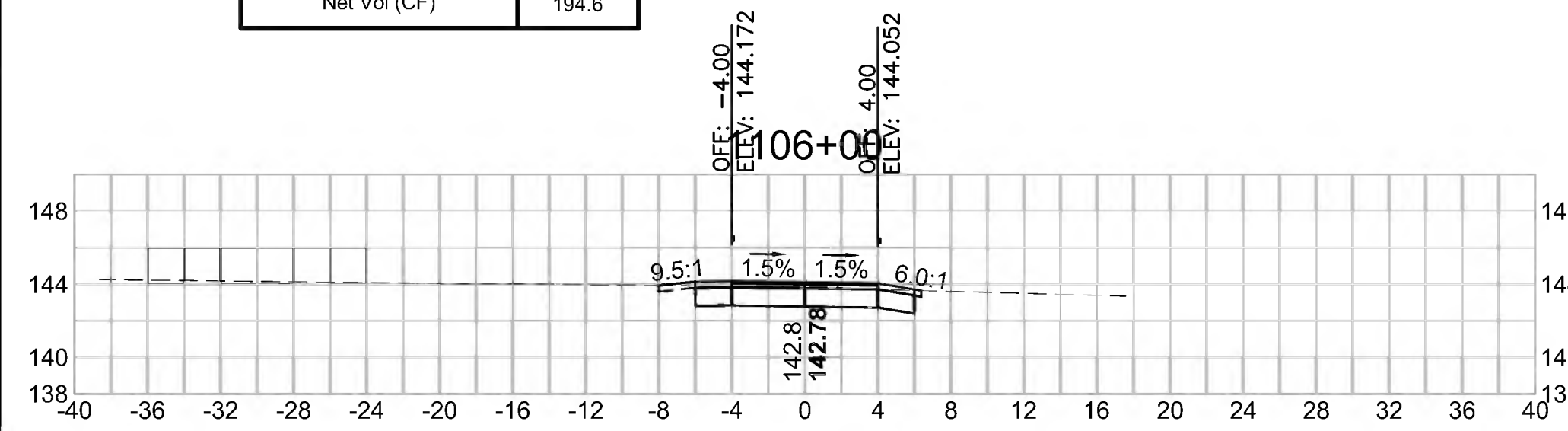

Total Volume at Station 1107+50.00	
Cut Area (SF)	9.520
Fill Area (SF)	0.169
Cut Vol (CF)	17.6
Fill Vol (CF)	0.2
Cum Cut Vol (CF)	307.6
Cum Fill Vol (CF)	54.4
Net Vol (CF)	253.3

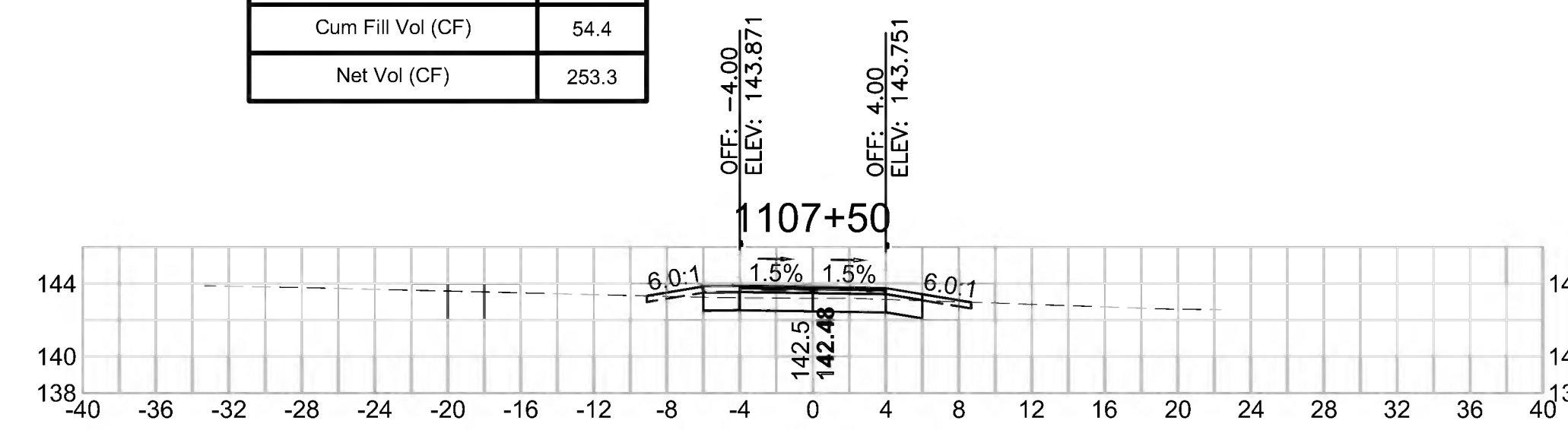

Total Volume at Station 1105+50.00	
Cut Area (SF)	14.923
Fill Area (SF)	0.000
Cut Vol (CF)	24.1
Fill Vol (CF)	0.0
Cum Cut Vol (CF)	222.5
Cum Fill Vol (CF)	54.1
Net Vol (CF)	168.4

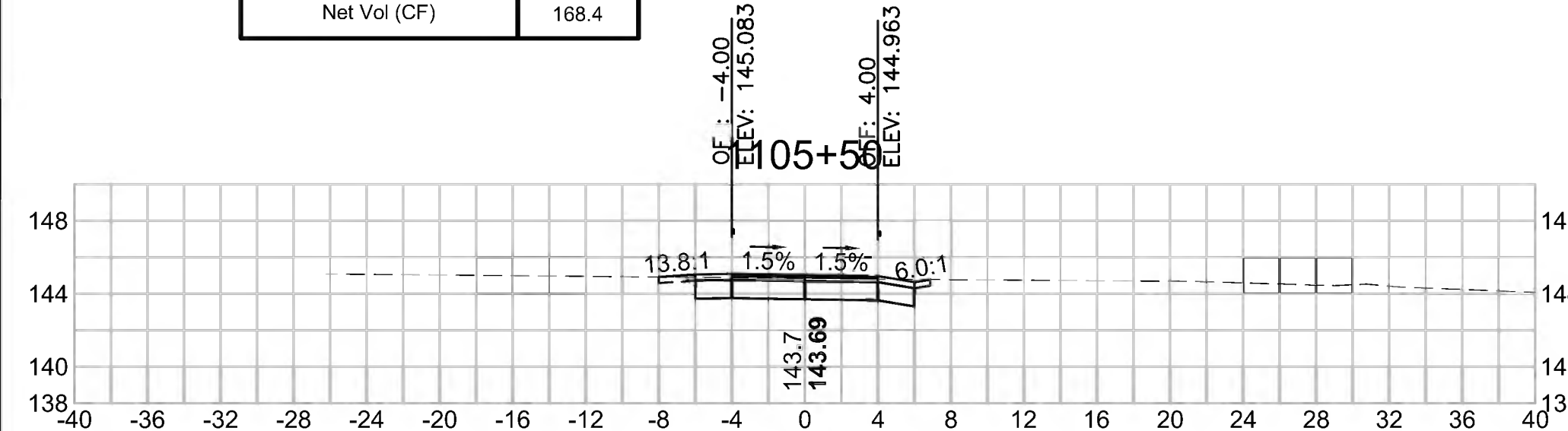

Total Volume at Station 1107+00.00	
Cut Area (SF)	9.448
Fill Area (SF)	0.063
Cut Vol (CF)	18.8
Fill Vol (CF)	0.1
Cum Cut Vol (CF)	290.1
Cum Fill Vol (CF)	54.2
Net Vol (CF)	235.9

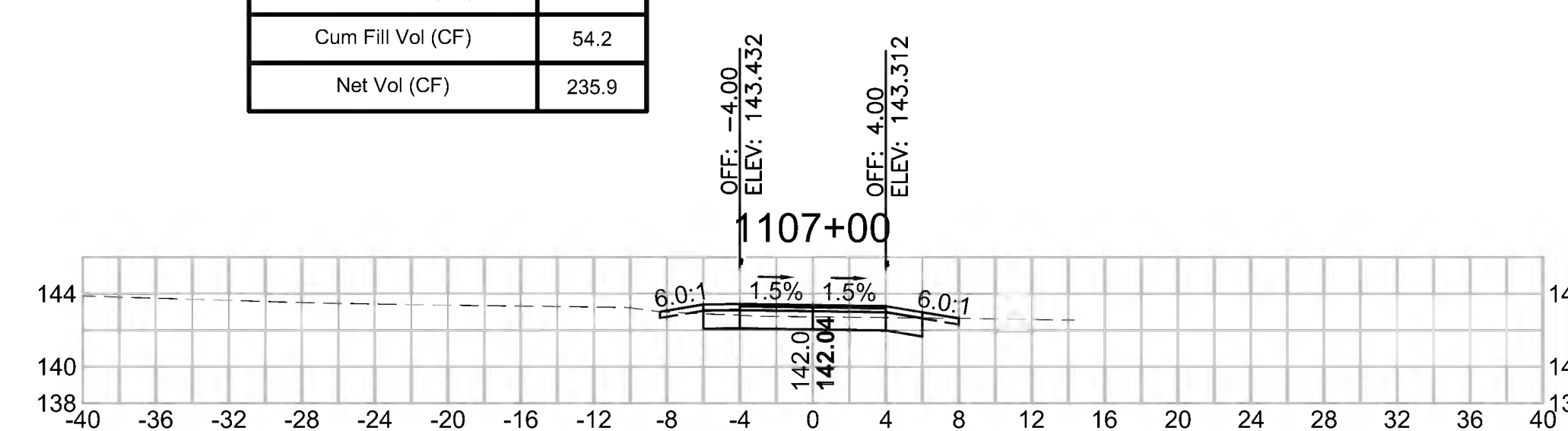

Total Volume at Station 1105+00.00	
Cut Area (SF)	11.073
Fill Area (SF)	0.028
Cut Vol (CF)	20.3
Fill Vol (CF)	0.1
Cum Cut Vol (CF)	198.4
Cum Fill Vol (CF)	54.1
Net Vol (CF)	144.3

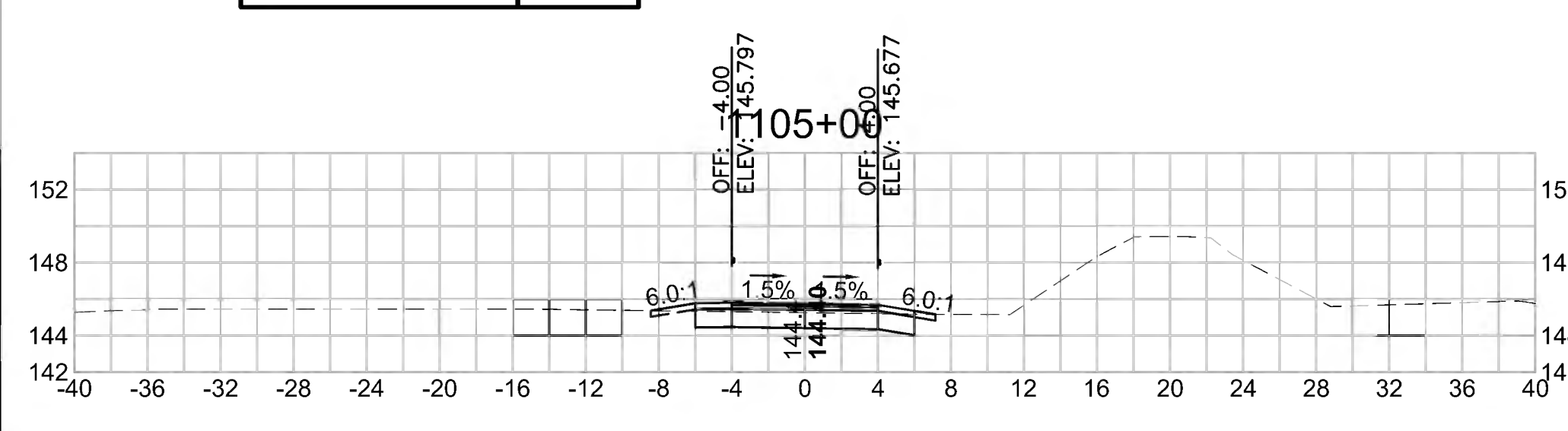

Total Volume at Station 1106+50.00	
Cut Area (SF)	10.901
Fill Area (SF)	0.002
Cut Vol (CF)	22.5
Fill Vol (CF)	0.0
Cum Cut Vol (CF)	271.2
Cum Fill Vol (CF)	54.1
Net Vol (CF)	217.1

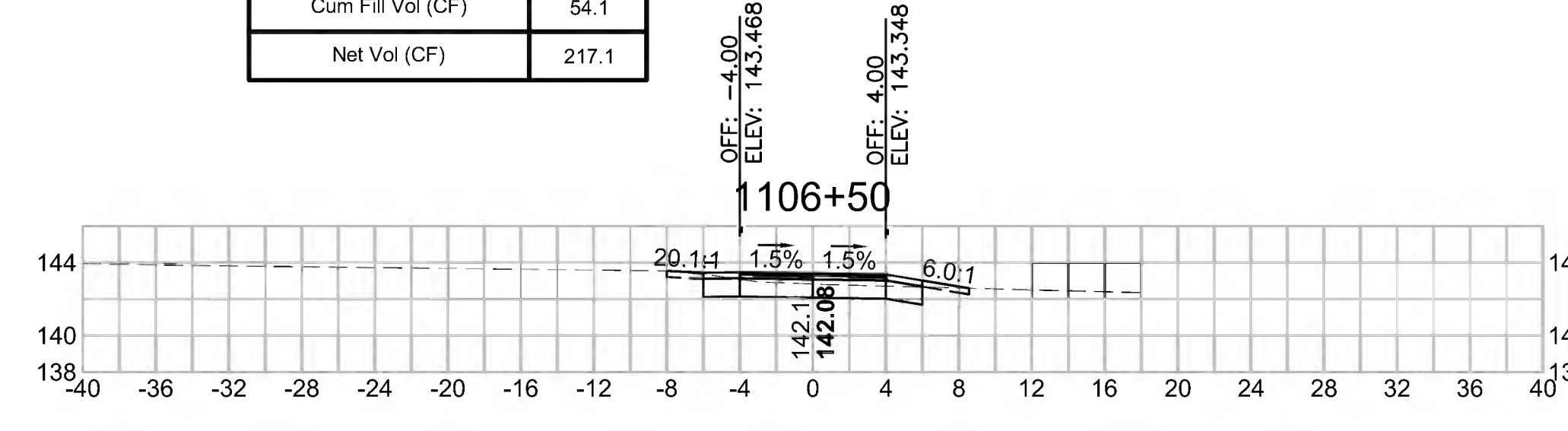

SUDBURY
BRUCE FREEMAN RAIL TRAIL

STATE	FED. AID PROJ. NO.	SHEET NO.	TOTAL SHEETS
MA	XXX-XXXX(XXX)X	305	319

CROSS SECTIONS
HUDSON ROAD

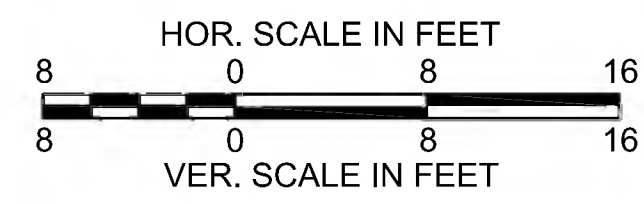

501+25

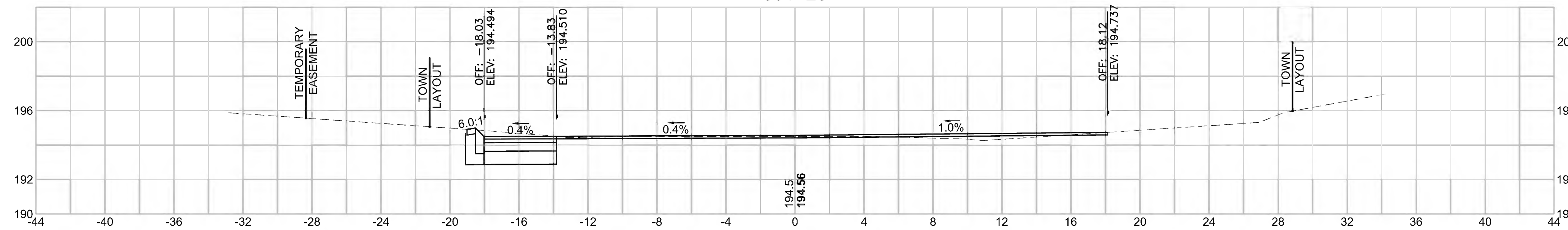

Total Volume at Station 501+25.00	
Cut Area (SF)	19,339
Fill Area (SF)	1,373
Cut Vol (CF)	18.8
Fill Vol (CF)	1.3
Cum Cut Vol (CF)	43.3
Cum Fill Vol (CF)	2.0
Net Vol (CF)	41.3

501+00

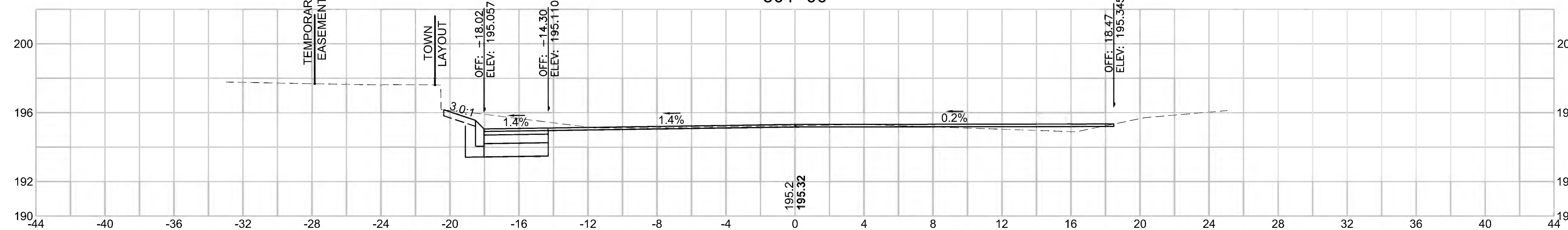

Total Volume at Station 501+00.00	
Cut Area (SF)	21,351
Fill Area (SF)	1,499
Cut Vol (CF)	15.0
Fill Vol (CF)	0.7
Cum Cut Vol (CF)	24.4
Cum Fill Vol (CF)	0.7
Net Vol (CF)	23.7

500+75

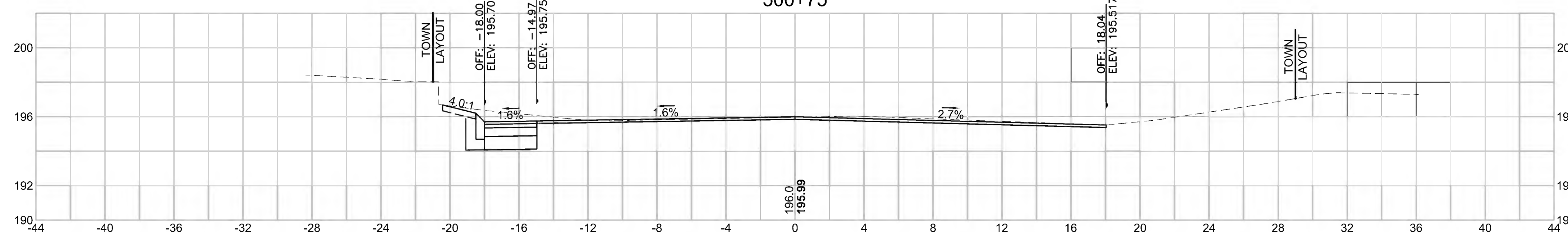

Total Volume at Station 500+75.00	
Cut Area (SF)	11,018
Fill Area (SF)	0,000
Cut Vol (CF)	9.5
Fill Vol (CF)	0.0
Cum Cut Vol (CF)	9.5
Cum Fill Vol (CF)	0.0
Net Vol (CF)	9.5

500+50

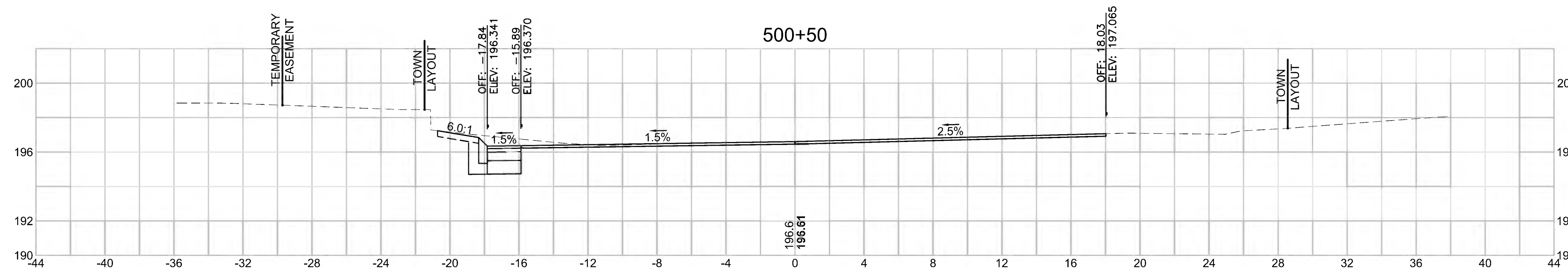

Total Volume at Station 500+50.00	
Cut Area (SF)	9,404
Fill Area (SF)	0,000
Cut Vol (CF)	0.0
Fill Vol (CF)	0.0
Cum Cut Vol (CF)	0.0
Cum Fill Vol (CF)	0.0
Net Vol (CF)	0.0

SUDBURY
BRUCE FREEMAN RAIL TRAIL

STATE	FED. AID PROJ. NO.	SHEET NO.	TOTAL SHEETS
MA	XXX-XXXX(XXX)X	306	319

CROSS SECTIONS
HUDSON ROAD

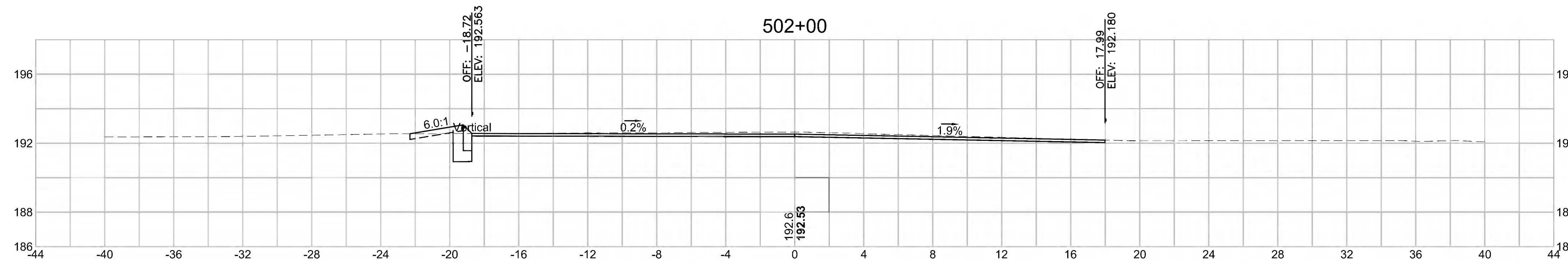
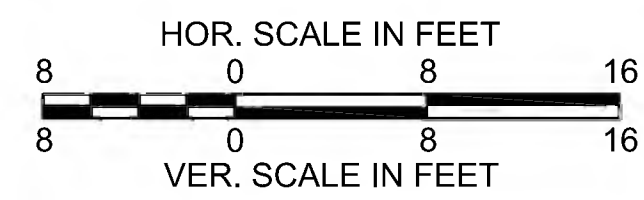

Total Volume at Station 502+00.00	
Cut Area (SF)	22.126
Fill Area (SF)	0.086
Cut Vol (CF)	11.4
Fill Vol (CF)	0.9
Cum Cut Vol (CF)	85.2
Cum Fill Vol (CF)	5.4
Net Vol (CF)	79.8

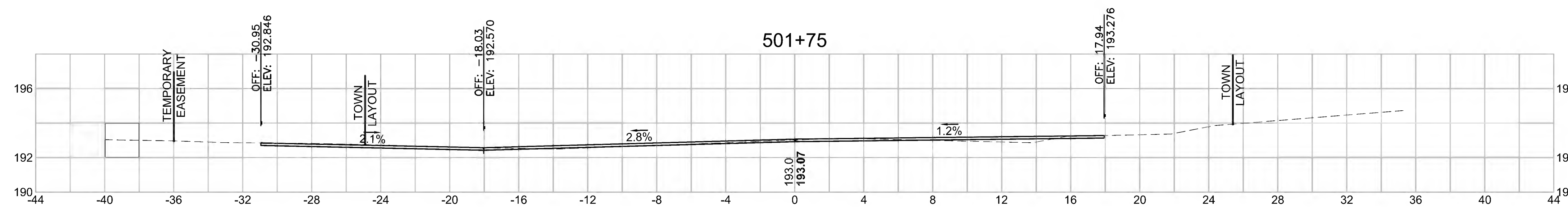

Total Volume at Station 501+75.00	
Cut Area (SF)	2.528
Fill Area (SF)	1.892
Cut Vol (CF)	11.4
Fill Vol (CF)	1.4
Cum Cut Vol (CF)	73.8
Cum Fill Vol (CF)	4.5
Net Vol (CF)	69.3

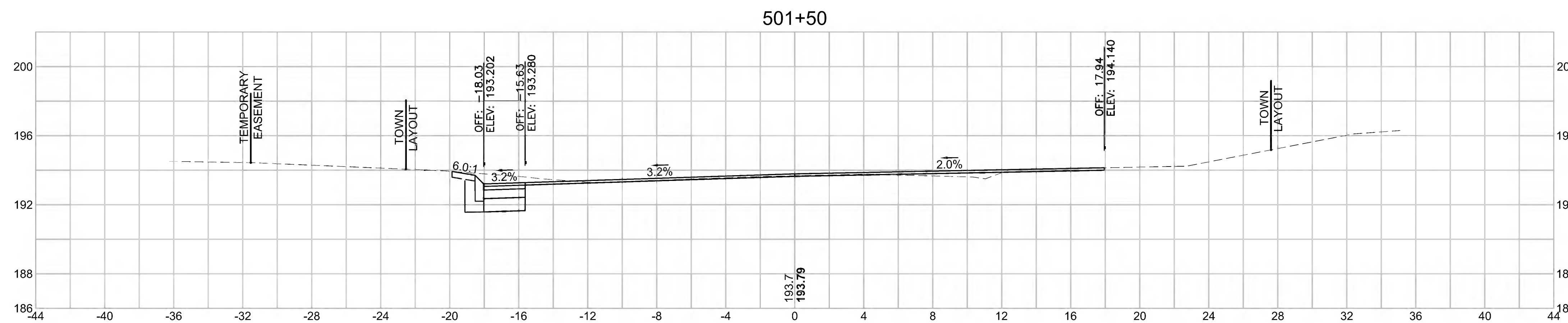

Total Volume at Station 501+50.00	
Cut Area (SF)	22.022
Fill Area (SF)	1.027
Cut Vol (CF)	19.1
Fill Vol (CF)	1.1
Cum Cut Vol (CF)	62.4
Cum Fill Vol (CF)	3.1
Net Vol (CF)	59.3

CROSS SECTIONS
HUDSON ROAD

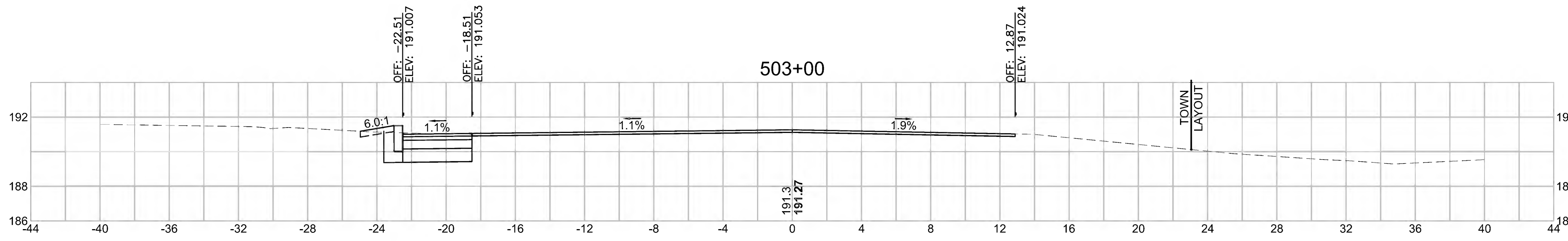
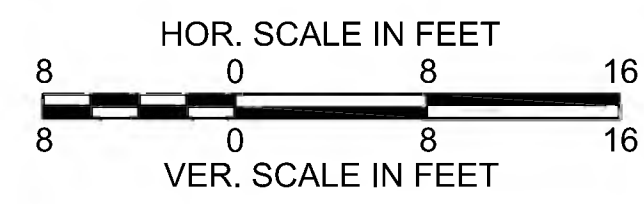

Total Volume at Station 503+00.00	
Cut Area (SF)	29,184
Fill Area (SF)	5,560
Cut Vol (CF)	29.8
Fill Vol (CF)	2.8
Cum Cut Vol (CF)	175.3
Cum Fill Vol (CF)	8.8
Net Vol (CF)	166.4

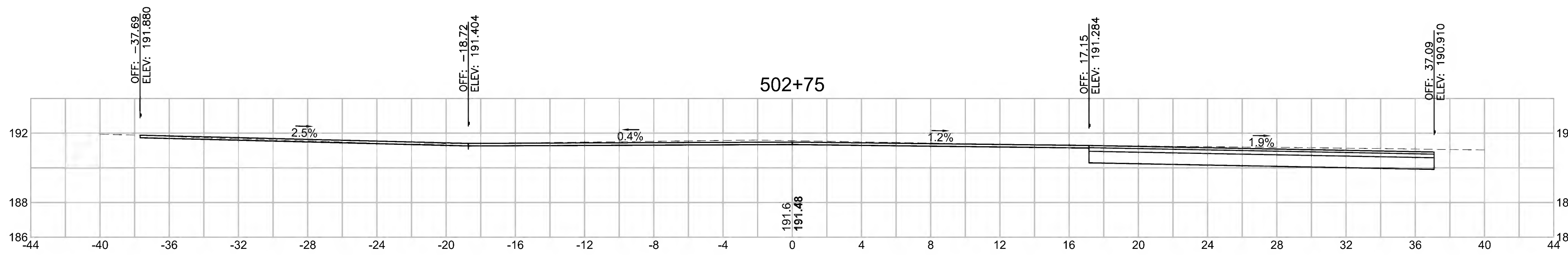

Total Volume at Station 502+75.00	
Cut Area (SF)	35,160
Fill Area (SF)	0,535
Cut Vol (CF)	26.6
Fill Vol (CF)	0.2
Cum Cut Vol (CF)	145.5
Cum Fill Vol (CF)	6.0
Net Vol (CF)	139.5

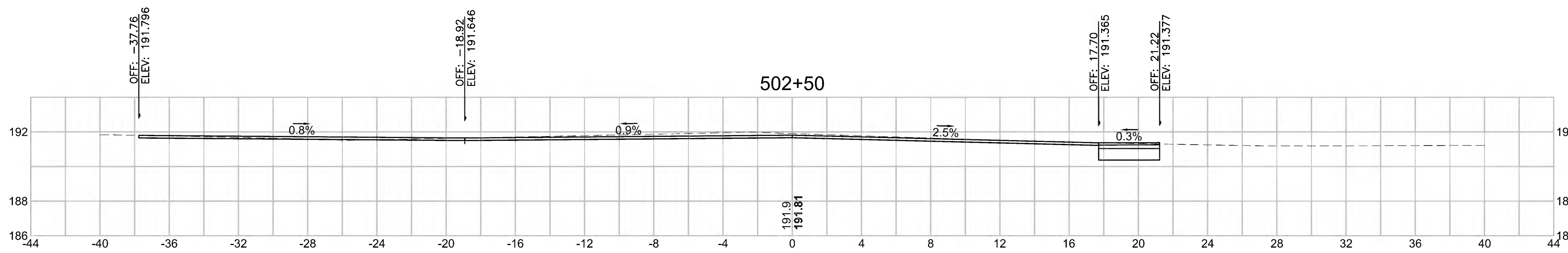

Total Volume at Station 502+50.00	
Cut Area (SF)	22,276
Fill Area (SF)	0,000
Cut Vol (CF)	16.9
Fill Vol (CF)	0.2
Cum Cut Vol (CF)	118.9
Cum Fill Vol (CF)	5.8
Net Vol (CF)	113.1

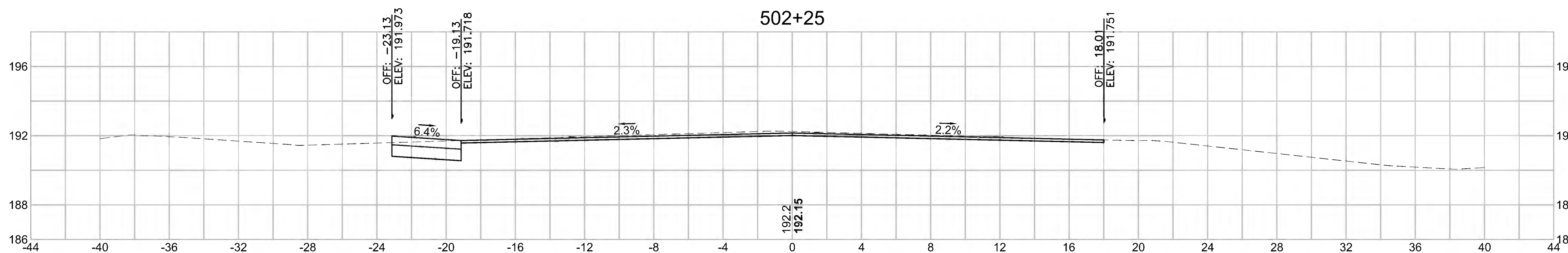

Total Volume at Station 502+25.00	
Cut Area (SF)	14,164
Fill Area (SF)	0,336
Cut Vol (CF)	16.8
Fill Vol (CF)	0.2
Cum Cut Vol (CF)	102.0
Cum Fill Vol (CF)	5.6
Net Vol (CF)	96.4

SUDBURY
BRUCE FREEMAN RAIL TRAIL

STATE	FED. AID PROJ. NO.	SHEET NO.	TOTAL SHEETS
MA	XXX-XXXX(XXX)X	308	319

PROJECT FILE NO. 608164

CROSS SECTIONS
HUDSON ROAD

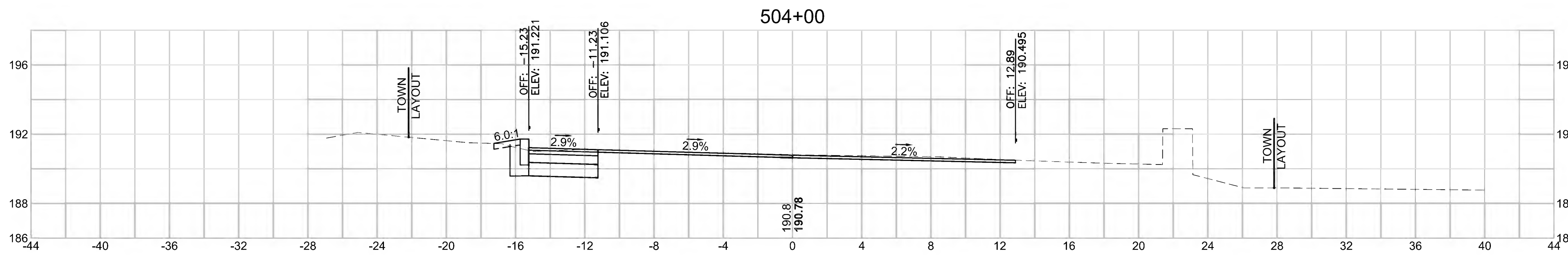
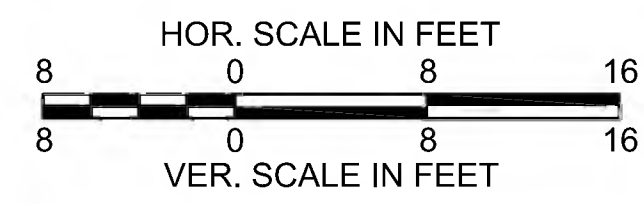

Total Volume at Station 504+00.00	
Cut Area (SF)	9.026
Fill Area (SF)	0.055
Cut Vol (CF)	16.0
Fill Vol (CF)	0.0
Cum Cut Vol (CF)	239.4
Cum Fill Vol (CF)	13.8
Net Vol (CF)	225.6

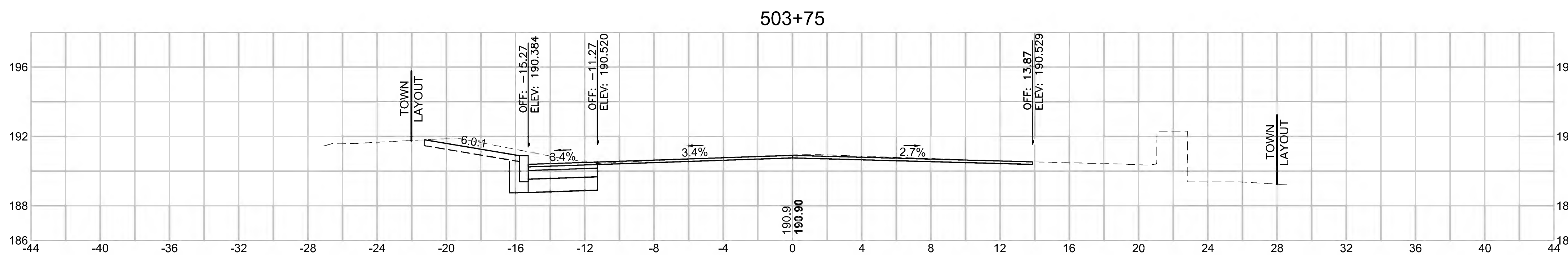

Total Volume at Station 503+75.00	
Cut Area (SF)	25.454
Fill Area (SF)	0.000
Cut Vol (CF)	17.7
Fill Vol (CF)	0.2
Cum Cut Vol (CF)	223.4
Cum Fill Vol (CF)	13.8
Net Vol (CF)	209.6

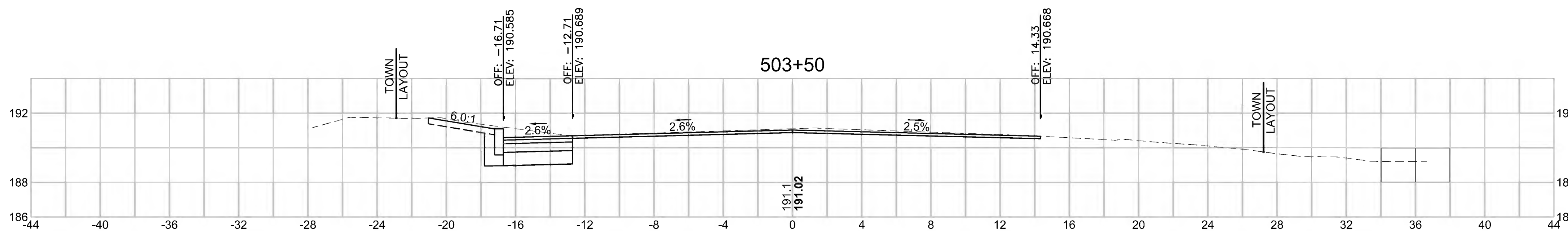

Total Volume at Station 503+50.00	
Cut Area (SF)	12.869
Fill Area (SF)	0.405
Cut Vol (CF)	11.4
Fill Vol (CF)	1.2
Cum Cut Vol (CF)	205.7
Cum Fill Vol (CF)	13.6
Net Vol (CF)	192.1

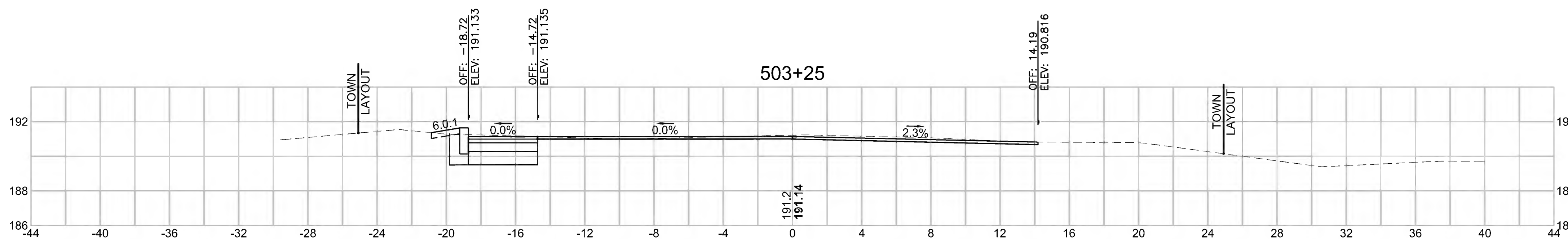

Total Volume at Station 503+25.00	
Cut Area (SF)	11.807
Fill Area (SF)	2.169
Cut Vol (CF)	19.0
Fill Vol (CF)	3.6
Cum Cut Vol (CF)	194.2
Cum Fill Vol (CF)	12.4
Net Vol (CF)	181.8

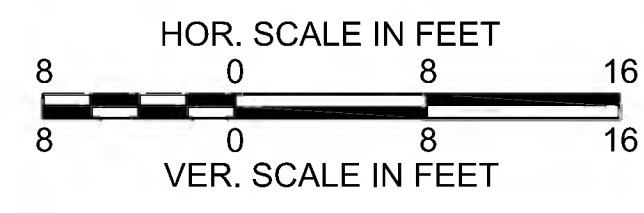

SUDBURY
 BRUCE FREEMAN RAIL TRAIL

STATE	FED. AID PROJ. NO.	SHEET NO.	TOTAL SHEETS
MA	XXX-XXXX(XXX)X	309	319

PROJECT FILE NO. 608164

CROSS SECTIONS
 HUDSON ROAD

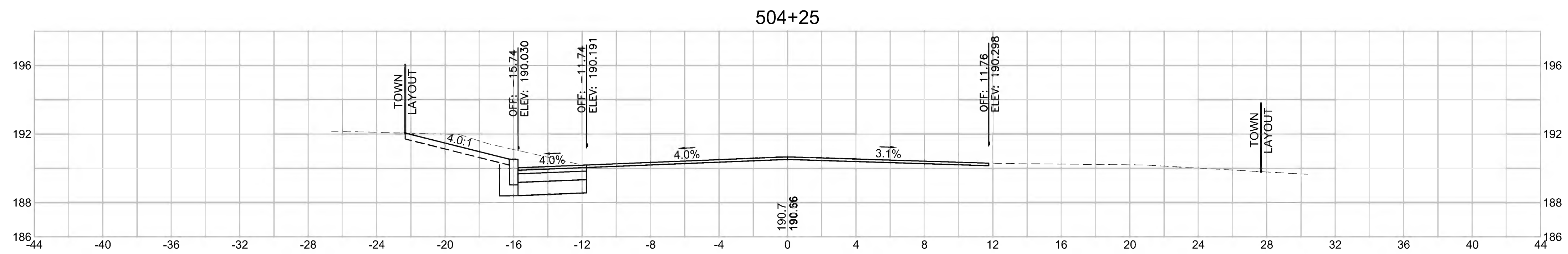

Total Volume at Station 504+25.00	
Cut Area (SF)	15.866
Fill Area (SF)	0.000
Cut Vol (CF)	11.5
Fill Vol (CF)	0.0
Cum Cut Vol (CF)	250.9
Cum Fill Vol (CF)	13.8
Net Vol (CF)	237.1