

David W. Burke
WETLANDS RESOURCE SPECIALIST
16 Coburn Rd
Berlin MA
978-758-6957

November 12th, 2019

Lori Capone, Conservation Coordinator
Sudbury Conservation Offices
275 Old Lancaster Rd
Sudbury MA, 01776

Via: Email

Ref: 35 Stone Root Lane Rose Sunroom DEP #301-1276

Dear Lori:

I am writing on the behalf of Dr. and Mrs. David Rose owners at 35 Stone Root Lane. I am writing I in order to provide materials requested by the Sudbury Conservation Commission meant to supplement our Notice of Intent Application package which remains under review by the board.

We were tasked with a request to investigate an alternative means of foundation support for the proposed building. It was agreed that importing and forming concrete behind the Rose home would be very challenging logistically not to mention expensive.

Peter Lavenson Construction Manager for New England Sunrooms suggested a Helical Pier system. We have researched the idea and had the architect review it for this job. At this point we are open to deploying the Helical Pier support system if the SCC and Sudbury Building inspector allow it to be used. Attached are supporting documents and photos describing the Helical Pier process of installation and general application.

I have used it on other jobs. It is generally meant to be less invasive and have less impact to the area at hand it also does not require stockpiling and does not compact soils.

Mitigation

We also discussed the need for offsetting mitigation for a small concrete pad which sits under a generator and for what appears to be an access road or cart path to the rear of the yard. There were photos of both at the hearing.

I think following the sunroom project we could certainly "Abandon" the formal tracked access to the rear yard and aerate it, loam it and seed it and relinquish it back to lawn.

As far as meaningful mitigation on this property goes a few things should be considered:

- **Most of the approximately 5-acre parcel is under CR already**
- **90% is heavily wooded**
- **There remains no logical place to plant native plants and remove nonnative invasives outside the CR.**
- **There are 2 streams which traverse and join on the property in what is very good wood duck habitat.**

2.

The applicant is willing to install 2 wood duck (Merganser, screech owl, woodpecker) boxes on posts within the wetlands portion of the property to be purchased and installed at their expense. They will be high quality wooden boxes; accessible by a monitor to be cleaned as needed.

Both boxes will be installed this winter in time for return of the birds in April. I trust this is adequate to offset the unpermitted uses described within.

Sincerely,

Dave Burke

**Wetlands Resource Specialist
Wildlife Biologist**





What is a Helical Anchor/Pile?

- A helical anchor/pile consists of one or more helix-shaped bearing plates attached to a central shaft, which is installed by rotating or "torqueing" into the ground. Each helix is attached near the tip, is generally circular in plan, and formed into a helix with a defined pitch. Helical anchors/piles derive their load-carrying capacity through both end bearing on the helix plates and skin friction on the shaft.

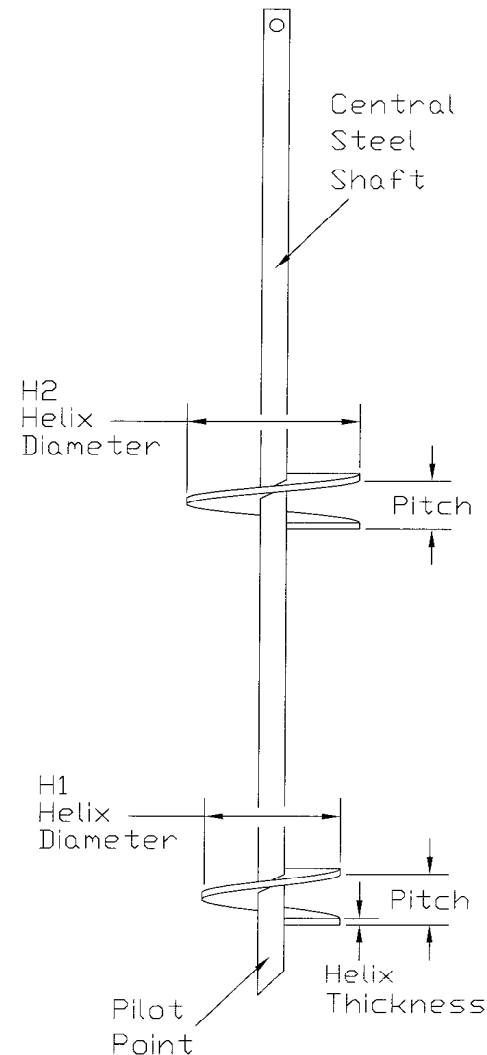

Extendable Helical Piles – Either Square or Round Shaft

**NO MORE THAN 6
HELICES PER ANCHOR**

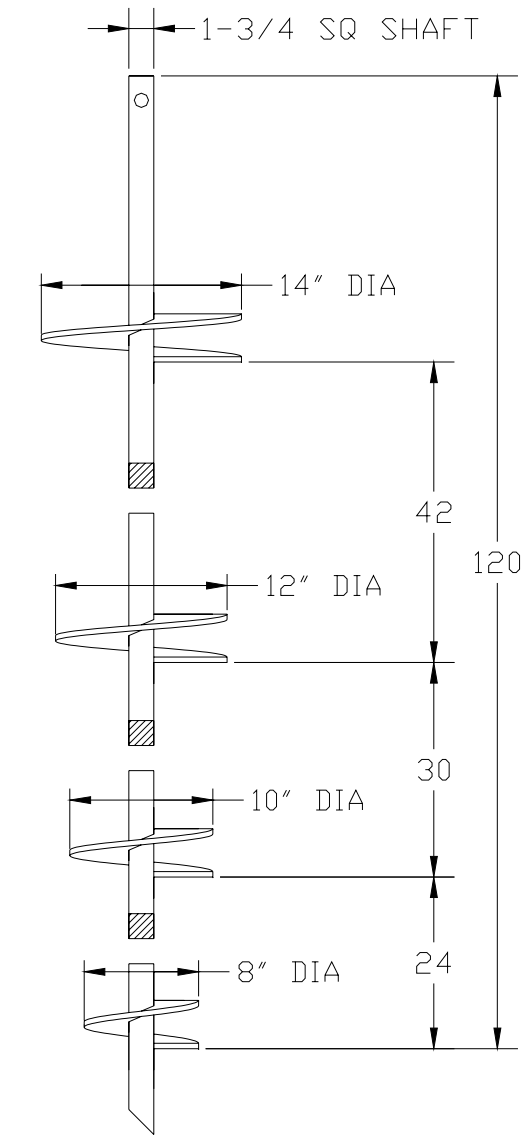

Lead Section

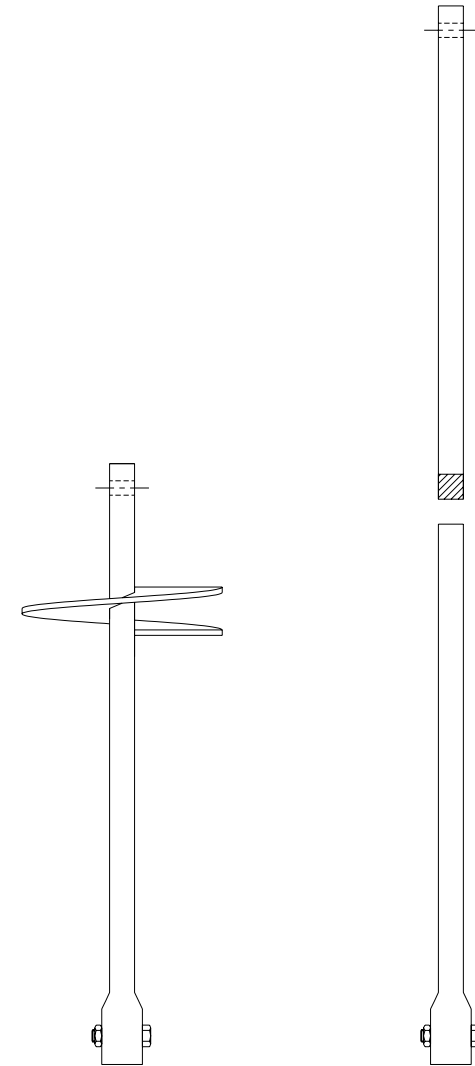

Helical Extension

Extension

Walkways for Wetlands



Portable Anchor Installers for small foundations

2,500 ft.-lb. torque capacity hydraulic power drive

**Economical manual operation and portability
for remote sites, common anchor installations**

For most shaft-driven guy anchors and smaller screw foundations, these compact drivers get into areas where large equipment cannot go or is impractical. Operator does not need to resist the torque generated by anchor installation. Countertorque transmits through a torque bar from the drive head to the earth or other restraint. This frees the operator for the task of guiding the anchor path.

Built-in bypass valve limits output to 2,500-ft.-lb.

maximum, two-way foot pedal gives operator direct control over drive and reverse directions, hoses (two 12-ft. and two 25-ft.) come with quick couplers for all connections from power supply to foot control to drive head. Pivoting drive-head yoke connects with bent-arm pin to square-tubular torque bar which telescopes from 8 feet to 10 feet as needed.



Catalog No. C303-1032

Medium-Duty Installer requires 1550 psi at 8 gpm flow rate to deliver 2,500 ft.-lb. maximum torque.

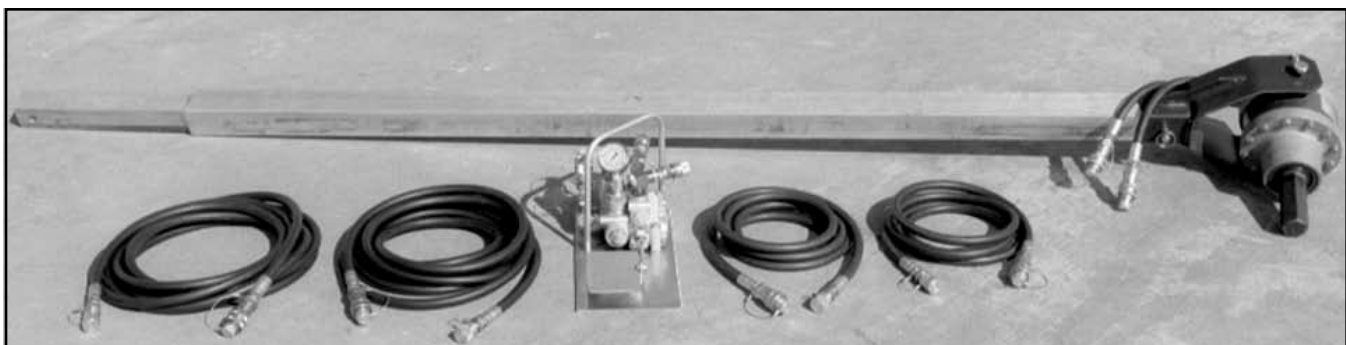

Catalog No. C303-1244

Heavy-Duty Installer requires 1,900 psi at 8 gpm flow rate to deliver 2,500 ft.-lb. maximum torque.

2,500 ft-lb Portable Anchor Installers Ordering Information

†Medium Duty — Catalog No. C303-1032

Grease filled gear case. Single Catalog Number above includes all items below. Each item also may be ordered by separate number.

*Hydraulic Control Valve	C303-1031
Two 25-ft. Hydraulic Hoses	C417-6121 (each)
*Hydraulic Drive Head	C303-1180
Yoke Assembly	E303-0680
*Two 12-ft. Hydraulic Hoses	E303-0876 (pair)
Square Torque Bar Assembly	E303-1041

Output shaft is 1½" square socket. Requires C303-1230 and flanged drive tool (order separately) to install anchors other than 1½" square 1¼" round shaft.

* Note: Hydraulic components are not interchangeable between C303-1032 and C303-1244.

Heavy Duty — Catalog No. C303-1244

Sealed oil-filled gear case. Single Catalog Number above includes all items below. Each item also may be ordered by separate number.

*Hydraulic Control Valve	C303-1247
Two 25-ft. Hydraulic Hoses	C417-6121 (each)
*Hydraulic Drive Head	C303-1233
Yoke Assembly	E303-0680
*Two 12-ft. Hydraulic Hoses	E303-1253 (pair)
Square Torque Bar Assembly	E303-1041

Output Shaft is 2" Hex. - Requires Kelly Bar Adapter P630013 and flanged drive tool (order separately) to install all anchors.

* Note: Hydraulic components are not interchangeable between C303-1032 and C303-1244.

Anchor Drive Tools

See page 8 for details on tools to drive specific anchor types.



†Adapter Tool
Catalog
No. C303-1230

†Note that all 5¼" bolt-circle tools may be connected directly to Heavy Duty Portable Anchor Installer Cat. No. C303-1244. †Adapter Tool Cat. No. C303-1230 is required to connect 5¼" bolt-circle tools to Medium Duty Portable Anchor Installer Cat. No. C303-1032. If needed, order Adapter C303-1230 as a separate item.

Optional Hydraulic Power Unit Catalog No. C303-1201

For easy wheeling to worksite, hydraulic drive head and foot control secure by rubber strap included to angle braces atop the cart frame and hoses ride on handles.

Cart-mounted on 5/8" diameter axle with two 4.80 x 8 inflatable (30psi) tires; 27¼" wide x 34½" high x 36" long; shipping weight with oil: 275 lb.

Hydraulic Pump with fan cooling system:

Typical output pressure 2500psi
Pump displacement 8 gpm @ 3400rpm
Reservoir capacity 5 gallons US
(shipping cap and vented fill cap provided)

Gasoline Engine System:

16hp Briggs & Stratton
Industrial/Commercial Model 326437, Type 2527
12-Volt pushbutton start, 3600rpm (maximum)

Operating instructions are included with anchor installer and hydraulic power unit.

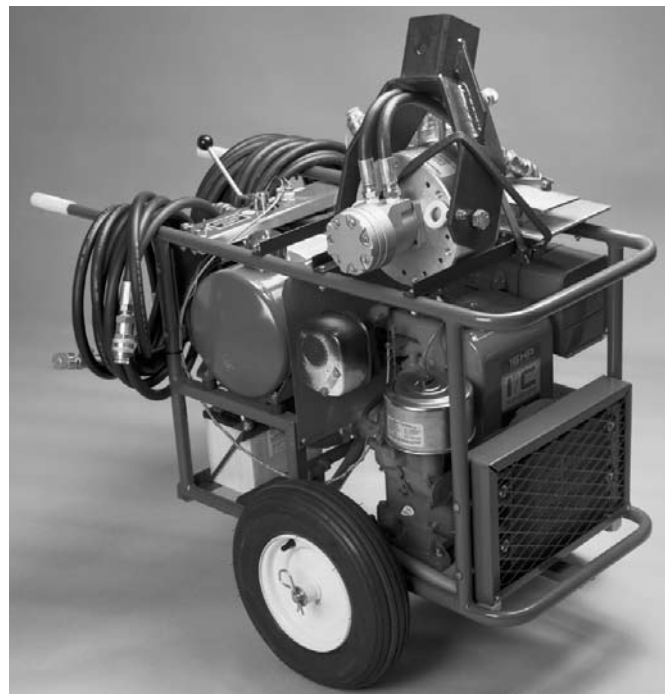

Anchor/Foundation Drive Heads

- Vehicle Mounted
- Hydraulic Powered
- 3,500, 6,000 & 11,500 ft.-lb. Torque Ratings

Specially suited for vertical installations of screw-type anchors, foundations, and bumper posts.

The drive head comes in two torque-rating ranges. The design also delivers other features for rugged field conditions.

- Precision planetary gears and bearings in oil-filled, sealed gearcase
- Heavy-duty output housing and bearings
- Heavy-duty bail flange mounted to gearcase housing provides balanced load-sharing torque restraint
- Dual-pin mounting provides drive-head positioning for controlled installations
- Drive-head also readily accepts earth augers for hole digging

Hose assemblies are not furnished with drive heads. For hydraulic flow more than 20 gpm, 3/4"-diameter hose is recommended. For flow rates of 20 gpm and below, 1/2" hose may be used. Swivel joint and swivel joint adapter are furnished. Thread size is 1"-11 1/2" NPSM (National Pipe Straight Mechanical).



Skid-Steer Utility Plate, Bail and Jib Components

To order, refer to information below and on next page. Specify one each: Drive Head, Utility Plate, Bail & Jib Assembly, and Kelly Bar Adapter.

3,500 and 6,000 ft.-lb. maximum torque

For Bobcat Skid-Steers ONLY:

Catalog No.	Description
C303-0999	3,500 ft.-lb. Utility Plate, Bail & Jib Assembly
C303-1014	6,000 ft.-lb. Utility Plate, Bail & Jib Assembly

Catalog Numbers at left do not include drive head, hoses or kelly bar adapter as shown at right.

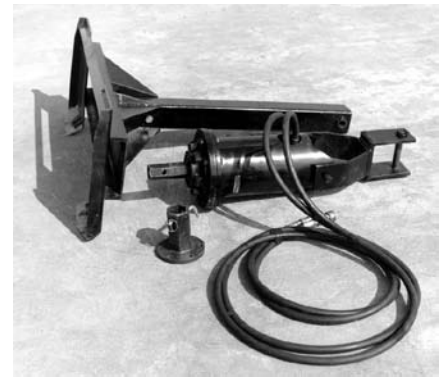

For Skid-Steers other than Bobcat:

(for field welding to utility plates on skid-steers)

C303-1015	3,500 ft.-lb. Bail & Jib Assembly less Utility Plate
C303-1016	6,000 ft.-lb. Bail & Jib Assembly less Utility Plate

Backhoe Mounting Components

To order, specify components in Typical Tool-String Assemblies on next page.

3,500, 6,000 and 11,500 ft.-lb. maximum torque

†Backhoe Mounting Brackets

Dimensions, inches		Backhoe Brand Name	Catalog Number	Bracket Description
*A	B			
10.1	1.5	Case	C303-0969	6K & 11.5K ft.-lb. Eskridge
10.1	1.0	Case	C303-0970	3.5K ft.-lb. Eskridge
7.00	1.5	JCB	C303-0971	6K & 11.5K ft.-lb. Eskridge
7.00	1.0	JCB	C303-0972	3.5K ft.-lb. Eskridge
8.18	1.5	John Deere	C303-0973	6K & 11.5K ft.-lb. Eskridge
8.18	1.0	John Deere	C303-0974	3.5K ft.-lb. Eskridge

*Bracket accepts boom up to 10.2" wide (1.75" dia. pin).
For booms 7" & 8.18" wide, 2 spacer bushings supplied.
Other bushings available for backhoes not listed.

